

# 센서 기반의 스마트 실내 식물 재배 시스템 개발

최우창\* · 홍현기\* · 조성훈\*\*

## Development of Sensor-Based Smart Indoor Gardening System

Woo-Chang Choi\* · Hyun-Ki Hong\* · Sung-Hun Jo\*\*

### 요 약

실내 식물의 긍정적인 효과에 관한 연구가 우리나라뿐만 아니라 전 세계에서 진행되고 있다. 우리나라 정부는 실내 식물의 긍정적인 효과를 인정하고 독거노인이나 환자에게 보급하는 정책을 실행하였다. 그러나 식물을 잘 키우고 유지하는 것은 바쁜 현대인들에게 쉽지 않은 일이다. 따라서 본 논문에서는 두 가지의 아날로그 센서와 세 가지의 인터페이스 회로를 이용하여 실내 전용 미니 스마트 재배 시스템을 설계하였다. 특히 식물에 가장 중요한 영양소인 물, 빛, 온도, 습도를 자동으로 제어하여 사람의 도움 없이도 식물이 잘 성장할 수 있도록 구성되었다.

### ABSTRACT

Research on the positive effects of indoor plants is being conducted not only in Korea but also globally. The Korean government has recognized these benefits and implemented a policy to distribute indoor plants to the elderly living alone and to patients. However, growing and maintaining plants can be challenging for busy modern people. Therefore, in this paper, we designed an indoor-only mini smart gardening system using two analog sensors and three interface circuits. The system is specifically configured to ensure that plants can thrive without human intervention by automatically controlling essential elements for plant growth, such as water, light, temperature, and humidity.

### 키워드

Circuit, Gardening, Schmitt Trigger, Sensor

## 1. Introduction

Recently, the benefits of indoor plants have gained attention and related research is actively underway [1]. As the psychological benefits of indoor plants are being proven the number of households growing indoor plants is increasing. According to related studies, activities involving

plant cultivation have been found to have a positive effect on children's nature-friendly attitudes and psychological health [2]. Furthermore, it has been revealed that ornamental plants have a positive impact on human psychology and indoor plants are being actively used for healing and therapeutic purposes[3].

The Korean government also recognizes these

\* 한국공학대학교 나노반도체공학과 (mogmog1010@tukorea.ac.kr, yellow6818@tukorea.ac.kr)

\*\* 교신저자 : 한국공학대학교 나노반도체공학과

• 접수일 : 2024. 08. 06

• 수정완료일 : 2024. 09. 08

• 게재확정일 : 2024. 10. 12

• Received : Aug. 06, 2024, Revised : Sep. 08, 2024, Accepted : Oct. 12, 2024

• Corresponding Author : Sung-Hun Jo

Dept. of Nano & Semiconductor Engineering, Tech University of Korea

Email : sunghun.jo@tukorea.ac.kr

effects and is distributing indoor plants to elderly people and patients living alone for healing purposes [4]. Due to these advantages, terms such as "companion plants," "horticultural therapy," and "healing farms" have recently emerged [5–6].

However, it is difficult for busy modern people to properly care for indoor plants. In this paper, an indoor-only mini smart gardening system was implemented for modern individuals who grow indoor plants.

In this paper, we miniaturized the smart gardening system and implemented a mini smart gardening system that controls water, light, temperature, and humidity, which are essential elements for plant growth.

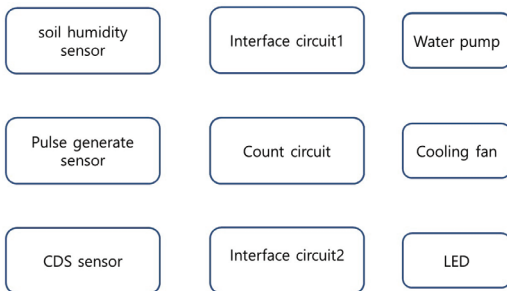

Fig. 1 Smart gardening system diagram

Figure 1 shows the configuration diagram of the smart gardening system. Information was collected through analog sensors, and the water pump and LED were controlled using analog and digital circuits. Additionally, a system that automatically ventilates at regular intervals was implemented using a pulse generation circuit and a counter circuit. By designing a circuit with a simple structure capable of performing specific functions, maintenance was made easy, and the likelihood of malfunction was minimized [7–8].

## II. Analog to digital conversion circuit

### 2.1 Automatic water supply system using Schmitt trigger circuit

An automatic water supply system circuit was designed using an analog soil moisture sensor where the output voltage changes depending on the moisture content of the soil. Figure 2 shows the overall circuit diagram of the automatic water supply system. The sensor used was YwRobot's Soil Moisture Sensor Module [SEN030003]. When using a standard comparator circuit, chattering may occur, or an accurate value may not be output near the threshold voltage. Therefore, a Schmitt trigger circuit using an OPAMP was implemented to compare the voltage output from the soil moisture sensor with the threshold voltage, converting it into a HIGH/LOW signal.

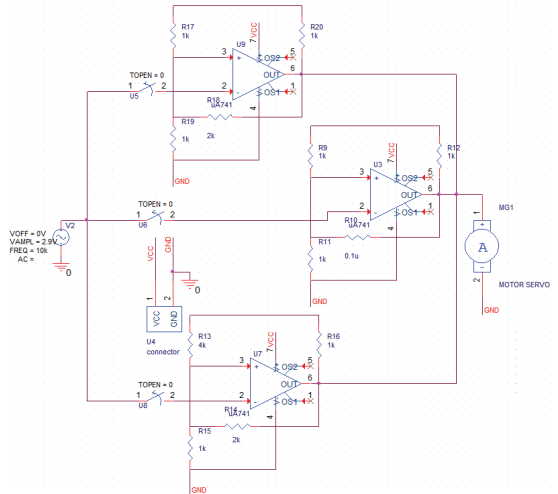

Fig. 2 Automatic water supply system using Schmitt trigger circuit

A Schmitt trigger has two threshold voltage values [9]. These values can be adjusted by varying the resistance in the circuit. In this study, three Schmitt trigger circuits were designed, with resistance values set to maintain humidity levels of

approximately 0% to 44%, 22% to 58%, and 55% to 83%, respectively. A switch was installed before each circuit to allowing users to individually control the on/off state of each circuit. The Schmitt trigger operates with two threshold voltages,  $V_{HT}$  and  $V_{LT}$ . When the input voltage exceeds  $V_{HT}$ , the output becomes HIGH, and when the input voltage falls below  $V_{LT}$ , the output becomes LOW. Figure 3 is an enlarged view of Circuit of figure 2.

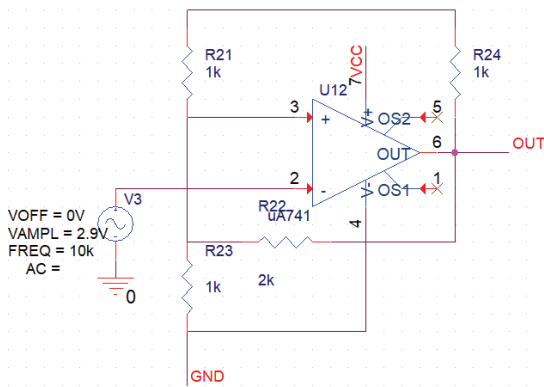

Fig. 3 Automatic water supply system circuit using Schmitt trigger circuit

$$V_{HT} = \frac{VCC \times R_2 \times (R_1 + R_3)}{R_1 \times R_2 + R_1 \times R_3 + R_3 \times R_2} \quad \dots (1)$$

$$V_{LT} = \frac{VCC \times R_2 \times R_3}{R_1 \times R_2 + R_1 \times R_3 + R_3 \times R_2} \quad \dots (2)$$

The threshold voltage values for the circuit in Figure 2 were calculated using the given formula, with  $V_{HT}=3V$ ,  $V_{LT}=2V$ , and  $VCC=5V$ . The formulas used to calculate the threshold voltage of the Schmitt trigger are presented in Equations (1) and (2). When an AC voltage that oscillates between  $V_{HT}$  and  $V_{LT}$  is applied to the circuit in Figure 2, the simulation results are as shown in Figure 4.

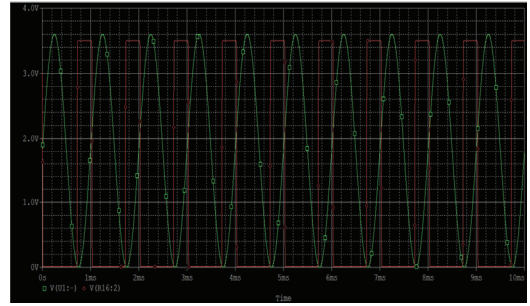

Fig. 4 Circuit 1 simulation results

## 2.2 Ventilation circuit operated at a constant cycle using counter circuit

Figure 5 illustrates the ventilation circuit, which operates on a regular cycle. A pulse generation circuit, based on the NE555 timer, generates a pulse of a specified period when a DC voltage is applied. The pulse start with a 6-digit counter and a 4-digit counter and are fed through a series of counters, resulting in a 24-digit counter circuit.

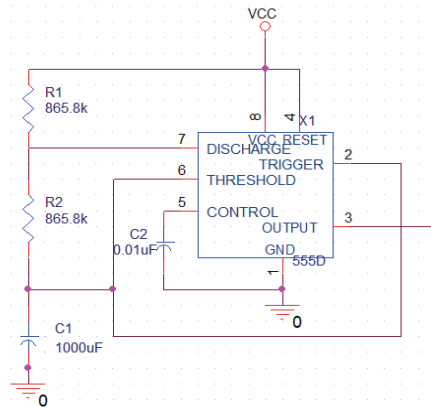

Fig. 5 Pulse generation circuit using NE555

The frequency and duty cycle of the pulse can be adjusted by modifying the values of C1, R1, and R2 in the circuit. The formulas to calculate the frequency and duty cycle are shown in Equations (3) and (4).

$$f = \frac{1.443}{(R_A + 2R_B)C} [Hz] \quad \dots (3)$$

$$D = \frac{R_A + R_B}{R_A + 2R_B} \times 100 [\%] \quad \dots (4)$$

By substituting the values from Figure 5 into the formulas, the calculated results are presented in Equations (5) and (6).

$$f = \frac{1.443}{(2597.4k)(1000\mu)} = 0.000556 [Hz] \quad \dots (5)$$

$$D = \frac{3463.2k}{5194.8k} \times 100 = 66.67 [\%] \quad \dots (6)$$

The calculated frequency of 0.000556 Hz corresponds to a cycle time of approximately 1800 seconds, or 30 minutes. This pulse is then sent to the 24-digit counter circuit, which is depicted in Figure 6.

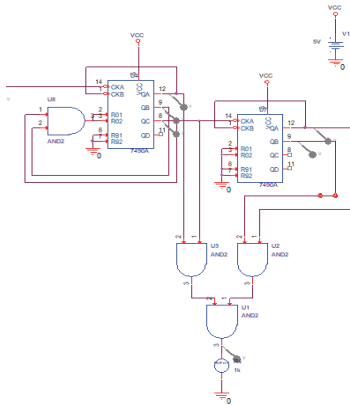

Fig. 6 24-digit counter circuit

The 30-minute pulse passing through the 24-digit counter generates a pulse every 12 hours, with each pulse lasting for 30 minutes. By combining the two circuits, we can confirm the final simulation results, as shown in Figures 7 and 8.

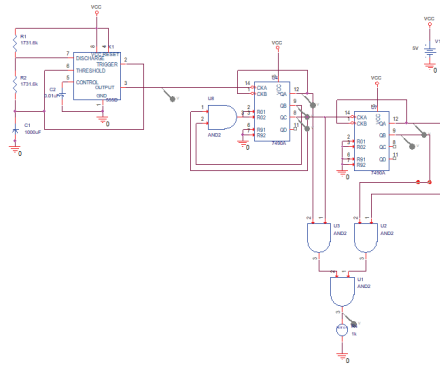

Fig. 7 Ventilation circuit

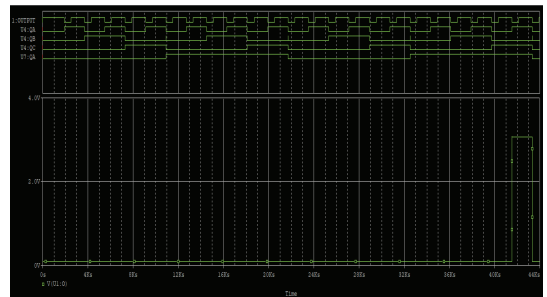

Fig. 8 Simulation results of ventilation circuit

The design ensures that the system operates for 30 minutes every 12 hours, which aligns with information from agricultural sources, such as rural women’s magazines, suggesting that a 30-minute ventilation period every 12 hours is optimal for plant growth.

### III. Analog circuit

#### 3.1 Light emitting circuit using CdS sensor

The light-emitting circuit is shown in Figure 9. This circuit takes advantage of the reduction in the internal resistance of the CdS sensor when exposed to light. Multiple LEDs can be connected in parallel in a voltage divider configuration, allowing more LEDs to light up as the surroundings become darker.

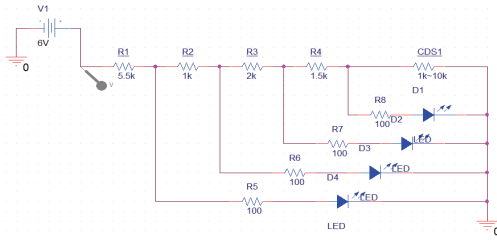

Fig. 9 Light-emitting circuit

In this configuration, the voltage across each LED can be determined based on the voltage division rule. Equations (7) to (10) represent the voltages applied to the four LEDs shown in Figure 9.

$$V_{D1} = V_1 \left( \frac{R_1 + R_2 + R_3 + R_4}{R_1 + R_2 + R_3 + R_4 + R_{Cds}} \right) [V] \quad \dots (7)$$

$$V_{D2} = V_1 \left( \frac{R_1 + R_2 + R_3}{R_1 + R_2 + R_3 + R_4 + R_{Cds}} \right) [V] \quad \dots (8)$$

$$V_{D3} = V_1 \left( \frac{R_1 + R_2}{R_1 + R_2 + R_3 + R_4 + R_{Cds}} \right) [V] \quad \dots (9)$$

$$V_{D4} = V_1 \left( \frac{R_1}{R_1 + R_2 + R_3 + R_4 + R_{Cds}} \right) [V] \quad \dots (10)$$

According to the CdS sensor's datasheet, its resistance is 1 kΩ in bright conditions and 10 kΩ in dark conditions. The voltages across each LED for both bright and dark conditions are calculated using equations (11) to (14).

$$V_{D1}: 3V \sim 5.45V \quad \dots (11)$$

$$V_{D2}: 2.55V \sim 4.64V \quad \dots (12)$$

$$V_{D3}: 1.95V \sim 3.54V \quad \dots (13)$$

$$V_{D4}: 1.65V \sim 3V \quad \dots (14)$$

By controlling the voltage in this way, all four LEDs can be lit in the darkest conditions, while only one LED remains on in the brightest. (LEDs turn on between 3 and 5V.) The corresponding resistance and voltage values for different light

levels are shown in Table 1.

Table 1. resistance and voltage according to light  
 <- Bright Dark ->

R(CdS)[ohm]	10k	7k	3k	1k
D				
D1	ON	ON	ON	ON
D2	OFF	ON	ON	ON
D3	OFF	OFF	ON	ON
D4	OFF	OFF	OFF	ON

#### IV. Conclusion

There has been growing interest in indoor plants, with numerous studies highlighting their positive effects. In this paper, we proposed a smart indoor gardening system that automates plant care. The system integrates analog and digital circuits to manage water, lighting, temperature, and moisture levels. With all elements controlled automatically, users can easily cultivate plants with minimal effort.

#### References

[1] Qin, Jun, et al. "The effect of indoor plants on human comfort." *Indoor and Built Environment* 23.5 (2014): 709-723. doi.org/10.1177/1420326X13481372

[2] Bringslimark, Tina, Terry Hartig, and Grete G. Patil. "The psychological benefits of indoor plants: A critical review of the experimental literature." *Journal of environmental psychology* 29.4 (2009): 422-433. doi.org/10.1016/j.jenvp.2009.05.001

[3] Tao, Jiang, et al. "Psychological and Physiological Relaxation Induced by Nature Working with Ornamental Plants." *Discrete Dynamics in Nature and Society* 2020.1 (2020): 6784512.

doi.org/10.1155/2020/6784512

- [4] Lee, JongYeol and Kim, Byeong-Man. "Growth Environment Monitoring System for Open-Field Smart Farms Using Big Data Model.." Journal of the Korea Institute of Information & Communication Engineering 28.1 (2024). 10.6109/jkiice.2024.28.1.47
- [5] Perry, Elaine, and Melanie Jayne R. Howes. "Medicinal plants and dementia therapy: herbal hopes for brain aging?." CNS neuroscience & therapeutics 17.6 (2011): 683-698. doi.org/10.1111/j.1755-5949.2010.00202.x
- [6] Song-Hee Lee, Hyun-Joo Kim, & Shin-A Cho (2023). The Effect of Horticultural Therapy Program on Brain Waves & Pulse Waves. Journal of the Korea Entertainment Industry Association,17(8),583-589, 10.21184/jkeia.2023.12.17.8.583
- [7] Kim, Jeong-Won. "An Effective Data Distribution Scheme in Sensor Network for Internet of Things." The Journal of the Korea institute of electronic communication sciences 10.7 (2015): 769-774. doi.org/10.13067/JKIECS.2015.10.7.769
- [8] Kim, Kyong-Ock, and Eung-Kon Kim. "Cycle-by-cycle plant growth automatic control monitoring system using smart device." The Journal of the Korea institute of electronic communication sciences 8.5 (2013): 745-750. doi.org/10.13067/JKIECS.2013.8.5.745
- [9] Filanovsky, I. M., and H. Baltes. "CMOS Schmitt trigger design." IEEE Transactions on Circuits and Systems I: Fundamental Theory and Applications 41.1 (1994): 46-49. doi.org/10.1109/81.260219

## 저자 소개



### 최우창(Woo-Chang Choi)

현재 한국공학대학교  
나노반도체공학과 재학

※관심분야 : 반도체집적회로설계



### 홍현기(Hyun-Ki Hong)

현재 한국공학대학교  
나노반도체공학과 재학

※관심분야 : 반도체집적회로설계



### 조성훈(Sung-Hun Jo)

현재 한국공학대학교  
나노반도체공학과 조교수

※관심분야 : 반도체집적회로설계