

# Simplification of a Feature-based 3D CAD Assembly Model Considering the Allowable Highest and Lowest Limits of the LOD

Eun-seop Yu<sup>\*</sup>, Hyunoh Lee<sup>\*</sup>, Soonjo Kwon<sup>\*\*</sup>, Jeong-youl Lee<sup>\*\*\*</sup>, Duhwan Mun<sup>\*,#</sup>

<sup>\*</sup>Department of Precision Mechanical Engineering, Kyungpook National University,

<sup>\*\*</sup>Mechanical Engineering Research Institute, Korea Advanced Institute of Science and Technology,

<sup>\*\*\*</sup>IT Convergence Research Team, Korean Register

## 허용 가능한 LOD의 상하한을 고려한 특징형상 3D CAD 조립체 모델의 단순화

유은섭<sup>\*</sup>, 이현오<sup>\*</sup>, 권순조<sup>\*\*</sup>, 이정렬<sup>\*\*\*</sup>, 문두환<sup>\*,#</sup>

<sup>\*</sup>경북대학교 정밀기계공학과, <sup>\*\*</sup>한국과학기술원 기계기술연구소, <sup>\*\*\*</sup>한국선급 IT융합연구팀

(Received 08 January 2020; received in revised form 03 March 2020; accepted 05 March 2020)

### ABSTRACT

Three-dimensional (3D) computer-aided design (CAD) models require different levels of detail (LODs) depending on their purpose. Therefore, it is beneficial to automatically simplify 3D CAD assembly models to meet the desired LOD. Feature-based 3D CAD assembly models typically have the lowest and highest feasible limits of LOD during simplification. In order to help users obtain a feasible simplification result, we propose a method to simplify feature-based 3D CAD assembly models by determining the lowest and highest limits of LOD. The proposed method is verified through experiments using a simplification prototype implemented as a plug-in type module on Siemens NX.

**Keywords :** 3D CAD Assembly Model(3D CAD 조립체 모델), Feature-based Method(특징형상 기반 방법), Level of Detail(상세도), Model Simplification(모델 단순화), Plug-in Type System(플러그인 타입 시스템), Siemens NX(Siemens NX)

### 1. Introduction

Three-dimensional (3D) computer-aided design (CAD) models have become an inevitable part of the product development process; however, the level of detail

(LOD) required in 3D CAD models varies at each stage according to the model's purpose and participants. Therefore, a 3D CAD model can be reused for a variety of purposes if the LOD can be adjusted to the desired level<sup>[1]</sup>. For example, in the plant industry, the 3D CAD model LOD required by an equipment manufacturer is different to that required by engineering, procurement, and construction

# Corresponding Author : [dhmun@knu.ac.kr](mailto:dhmun@knu.ac.kr)

Tel: +82-54-530-1271, Fax: +82-54-530-1278

(EPC). Thus, it is necessary to reduce the LOD of a 3D CAD model delivered by an equipment manufacturer until it is at the level required by EPC<sup>[2]</sup>.

At work sites, 3D CAD models with low LOD are typically recreated manually. This is because existing tools do not automatically adjust the LOD to satisfy worksite personnel requirements. As a result, the work can take a long time and the simplification quality may vary according to the worker. To resolve these problems, technology must be developed that can automatically adjust the LOD of 3D CAD models. Moreover, the normal product development results are produced in terms of assembly models rather than part models. Therefore, it is also important to develop technology that can simplify 3D CAD assembly models.

In order to simplify 3D CAD models, simplification operations and evaluation metrics are required<sup>[1]</sup>. A simplification operation involves removing 3D CAD model elements such as vertices, edges, faces, and features to create a simplified model<sup>[21]</sup>. The method of filling the empty spaces created by removing elements may differ according to the model's form of expression. Evaluation metrics quantitatively calculate the importance of each element comprising a 3D CAD model<sup>[3]</sup>. To do this, extracting the 3D model information required for the simplification including the assembly, parts, and features are necessary. It is also necessary to employ an algorithm to prevent undesirable results that can occur during the simplification process, such as model separation.

Model simplification systems can be developed as stand-alone type systems or plug-in type systems, which run on commercial 3D CAD systems. Plug-in type systems can be developed using the API (application program interface) provided by the commercial 3D CAD system. For example, a user can develop a program in the form of a library such as a DLL (dynamic link library) and register it in a

commercial 3D CAD system then use the system via the system UI (user interface). Stand-alone systems refer to simplification systems that run independently of commercial 3D CAD systems. Plug-in type systems are more familiar to users than stand-alone type systems because they use the UI and features provided by commercial 3D CAD systems. In addition, because they run on a commercial system, they are advantageous for tasks such as model editing.

3D CAD assembly models are composed of multiple parts, and the LOD required by each part varies according to the number and type of features that constitute the part, the part size, and the part location. Therefore, it is necessary to individually adjust the LOD of each part in the 3D CAD assembly model simplification process through user intervention<sup>[16]</sup>. To do this, an optimized simplification procedure and major functions must be developed while also considering user involvement. In particular, when the desired LOD is entered after the user selects the assembly components in the simplification process, it is important to check the permitted range of LOD and determine how the selected objects' subordinate components can be simplified. Here, components are the partial assemblies or parts that constitute an assembly model.

To provide this type of simplification, we propose a new feature-based 3D CAD assembly model simplification method. In this study, we first establish a simplification procedure then develop the major functions required for simplification. We also present a method for determining the permitted LOD for the components undergoing simplification and for applying a component locking mechanism for the subordinate components of the selected objects at the LOD-based simplification stage of the proposed procedure. The prototype system that supports the proposed simplification method is designed to run as a plug-in type system on Siemens NX using a simplification API developed in a previous study<sup>[4]</sup>. Finally,

simplification experiments are performed on a test model to verify the validity of the proposed method.

This paper is organized as follows. Chapter 2 analyzes existing studies on 3D CAD model simplification. Chapter 3 proposes the feature-based 3D CAD assembly model simplification procedure and major functions. Chapter 4 presents the method for determining the highest and lowest LOD limits of a component, as well as the method for simplifying the subordinate components of user-selected objects. Chapter 5 discusses the results of experiments that simplify a test model using the prototype system. Finally, Chapter 6 presents the conclusions of this study and future research areas.

## 2. Review of Related Studies

Existing studies on 3D CAD model simplification are divided into mesh-based methods<sup>[5-7]</sup>, boundary representation (B-rep)-based methods<sup>[8-10]</sup>, and feature-based methods<sup>[1-2, 11-13]</sup>. The following is a brief description of each method. Mesh-based methods are mainly used to adjust the LOD of a mesh model in the computer graphics field. For example, there is a need to adjust the LOD of a mesh model according to the user's viewpoint in a virtual reality environment. Specifically, LOD is determined in real time by the user's viewpoint and distance, pixel size, eccentricity, and the relative speed compared to the user<sup>[14]</sup>. In order to lower the LOD of a mesh model, the number of triangles that constitute the mesh must be reduced. Generally, a mesh model that has undergone proper simplification has a smaller number of triangles than existing models but the triangles are dense and regular<sup>[7]</sup>.

B-rep-based methods are divided into the dimension reduction method, feature suppression method, and volume decomposition method. The dimension reduction method reduces a 3D model's dimensions to 1 or 2 dimensions and is often used in pre-processing for finite element analysis. The feature suppression

method uses the model's topology information to find and remove shape elements that correspond to specific patterns<sup>[8]</sup>. The volume decomposition method decomposes the B-rep model into a collection of partial volumes then removes partial volumes that have low importance or correspond to certain conditions<sup>[9]</sup>.

The feature-based method calculates the importance of features using the simplification evaluation metrics then rearranges the order of the features<sup>[12]</sup>. Features are removed sequentially, starting with low-importance features. A model that fits the input LOD is then created. In such cases, all of the model's feature information is assumed to exist. Previous studies have focused on creating different evaluation metrics including feature types and volumes according to the model's purpose, as well as by calculating the importance of features.

Commercial systems and libraries, which provide the simplification functions of a 3D CAD model, include Arconicos' spGate, Elysium's CADdoctor, the Defeature module provided by Dassault Systemes' SolidWorks, and Spatial's ACIS. These systems support feature-based simplification (Defeature) and B-rep-based simplification (spGate, CADdoctor, and ACIS). Specifically, they support features that remove internal parts, select and remove features that satisfy certain conditions, or recognize and remove specific types of features (fillet, round, chamfer, hole, and boss) from the models.

## 3. Simplification of Feature-based 3D CAD Assembly Models

### 3.1 Assembly Model Simplification Procedure

The simplification process of a 3D CAD assembly model is largely divided into the preprocessing stage, the LOD-based simplification stage, and the results output stage, as shown in Fig. 1. Section 3.2 provides

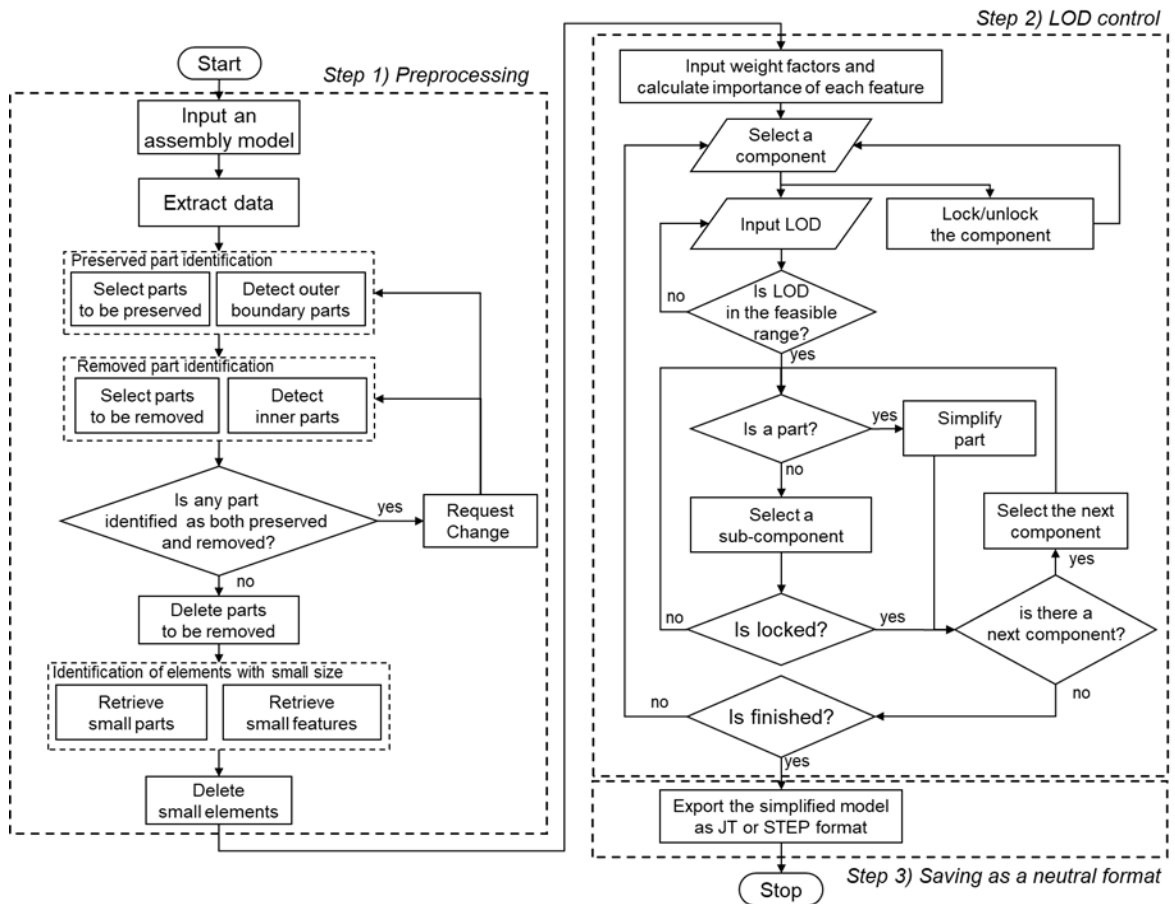

Fig. 1 Simplification procedure for a feature-based 3D assembly model

a detailed description of the major functions that constitute each stage.

The preprocessing stage identifies the parts to be preserved, then identifies and removes parts to be removed, before finally identifying and removing small elements. In the preprocessing stage, various data required for simplification are first extracted from the input model. After data extraction, the parts to be preserved and removed are identified. The parts to be preserved and removed are selected directly by the user or automatically detected by the system. The automatically detected parts to be preserved are parts located at the outer boundaries. The automatically detected parts to be removed are the internal parts

that are not seen on the exterior. If there is overlap between the lists of parts identified for preservation or removal, the system requests the user to change the lists. If there is no overlap, the parts to be removed are removed and the small elements are identified and removed.

The LOD-based simplification stage calculates the importance of the 3D CAD assembly model's remaining features after preprocessing. In addition, the user selects components and enters the desired LOD. The entered target LOD is examined to determine if it corresponds with the highest and lowest limits of the components' permitted LOD. Then, the LOD of the 3D CAD assembly model is adjusted by

sequentially removing low-importance features. This process uses component locking and unlocking functions. Locked components are excluded from the list of simplification targets. The results output stage saves the fully simplified 3D CAD assembly model in a neutral file format such as STEP (standard for the exchange of product model data, ISO 10303)<sup>[17]</sup>, or JT (jupiter tessellation, ISO 14306)<sup>[18]</sup>.

## 3.2 Major Simplification Functions

### 3.2.1 Data Extraction

The data extraction function extracts the data required for simplification from the 3D CAD assembly model. The extracted data includes the (partial) assembly list and information, the part list for each assembly, the volume and feature list for each part, and the detailed information for each feature (a list of features includes each feature's name, ID, type, volume, dimensions, and reference relationships). However, data and assembly constraint conditions are not extracted because they are not used in the proposed simplification process.

### 3.2.2 Searching for Parts Located at Outer Boundaries

A product's outer boundary is important information that affects physical interference between products. Therefore, it is necessary to minimize changes to the dimensions of the outer boundary of a product during the simplification process. To do this, parts on the outer boundaries are detected from all parts in the 3D CAD assembly model and are not removed during the simplification process.

To find parts located at the outer boundaries, the assembly model's boundary box is calculated as in Fig. 2(a). Then, a body with a fixed thickness is created as the inner part of the boundary box (Fig. 2(b)). The thickness of the body is 5% of the assembly model boundary box's vertical, horizontal, and height dimensions. Finally, the interference

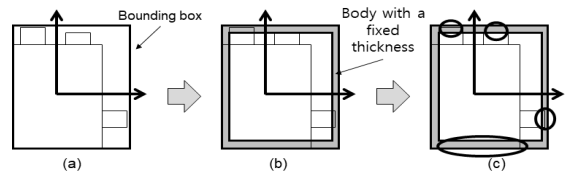

Fig. 2 Detection of parts located at the outer boundary of an assembly model

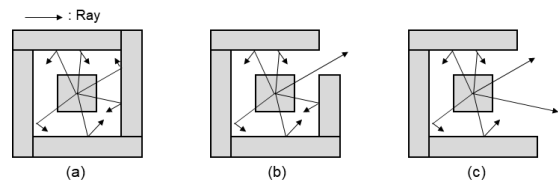

Fig. 3 Detection of internal parts that are hidden from the outside

between the boundary box body and the input parts is checked, and a decision is made as to whether the input part is located at the outer boundary.

### 3.2.3 Searching for Internal Parts

Internal parts are those not visible on the assembly model's exterior. Many previous studies<sup>[19-20]</sup> have removed internal parts because they do not affect the product's appearance during simplification. Therefore, internal parts are found and removed during the preprocessing stage, thereby increasing the simplification rate while maintaining the 3D CAD assembly model's appearance. If there are assembly constraint conditions related to a part during the part's removal process, the constraint conditions are removed along with the part.

As shown in Fig. 3, internal part detection uses the ray casting method, which is a type of hidden surface removal method. A boundary box is created in the target part then rays are cast in six directions from the boundary box: forward, backward, left, right, up, and down. If all cast rays hit other parts as in Fig. 3(a), the part is determined to be internal. If the rays do not hit anything (Figs. 3(b) and 3(c)), the part is not classed as internal.

### 3.2.4 Searching for Small Elements

Small elements are parts or features that are very small compared to the overall assembly model. Examples include parts with small volumes such as bolts and nuts, as well as small holes that are used to fasten parts and fillets/rounds/chamfers. In this study, the criterion by which small parts were judged was the volume for parts, the diameter for hole features, the radius for fillet/round features, and the sectional area for chamfer features. The small element search stage finds and removes small parts or features that have a smaller criterion of judgment value than the user-entered value.

### 3.2.5 Calculating Feature Importance

In the feature-based simplification method, it is necessary to calculate the importance of the features that constitute the model. The importance of a feature is calculated by Eq. (1).

$$F_i = w \cdot |V_i| \quad (1)$$

where  $F_i$  is the importance of feature  $i$  and  $V_i$  is the volume of feature  $i$ . The volume of a feature is one of the most commonly used criteria for calculating the importance of a feature in feature-based simplification studies<sup>[1,9,11-13]</sup>.  $w$  is the weight according to the feature's creation type.

Different values are given according to whether a

feature is additive or subtractive. Additive features usually have a greater influence on people's recognition of a model's overall shape than subtractive features. Therefore, previous simplification studies<sup>[11, 15]</sup> have given additive features more importance than subtractive features. Similarly, we assigned a basic weight of 1.2 to additive features and a basic weight of 0.8 to subtractive features. In addition, the weight values can be changed according to the needs of the user.

In order to determine the importance of features, the volume of each feature must be calculated. However, commercial 3D CAD systems typically only provide a volume calculation function for the part model's body and do not provide separate functions for calculating the feature volume. Therefore, this study calculated the volume of each feature, as shown in Fig. 4. If a new solid  $S_n$  is created from a Boolean function of the existing solid  $S_p$  and the feature  $F_i$ , the volume of feature  $F_i$  can be calculated as the difference in volume between solid  $S_p$  and solid  $S_n$ . If the calculated volume value is positive, the feature is judged to be an additive feature. If it is negative, the feature is judged to be a subtractive feature.

### 3.2.6 LOD-based Simplification

The LOD-based simplification feature removes the features that are subordinate to the user-selected

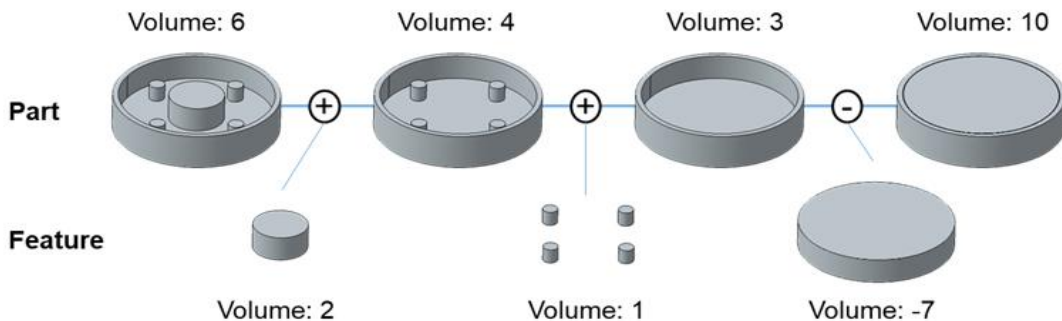

Fig. 4 Measuring the volume of each feature in a part model

component until the component arrives at the user-entered LOD. Features are removed sequentially, starting with features of low importance within a part. A component's LOD is calculated by Eq. (2).

$$LOD = (\Sigma N - \Sigma N_d) / \Sigma N \times 100\% \quad (2)$$

where  $\Sigma N$  is the number of all features included in the user-selected component and  $\Sigma N_d$  is the number of features removed from the user-selected component. Eq. (3) calculates the number of features that must be additionally removed from the user-selected component in order to satisfy the LOD entered by the user.

$$N_{ad} = \Sigma N_{present} - \Sigma N \times LOD_{target} \quad (3)$$

where  $N_{ad}$  is the number of features that must be additionally removed from the user-selected component,  $\Sigma N_{present}$  is the number of features remaining in the current component,  $\Sigma N$  is the number of all features included in the component, and  $LOD_{target}$  is the user-entered LOD.

Eq. (4) calculates the number of features that must be removed for each subordinate part in the component.

$$N_{di} = \frac{N_i}{\Sigma N - (\Sigma N_p + N_r + \Sigma N_c)} \times N_{ad} \quad (4)$$

where  $N_{di}$  is the number of features that must be removed from part  $i$ , which is subordinate to the user-selected component,  $N_i$  is the number of features included in part  $i$ ,  $\Sigma N$  is the number of all features included in the component,  $\Sigma N_p$  is the total number of features included in all preserved parts that are subordinate to the component,  $\Sigma N_r$  is the total number of features included in all removed parts that are subordinate to the component, and  $\Sigma N_c$  is the total number of features included in all locked components that are subordinate to the component. In short, as a subordinate component has more features

than other components, more features are removed. The number of features must be an integer number; therefore, if  $N_{di}$  is not an integer number, it is rounded to the nearest integer number.

### 3.2.7 Feature Removal

To remove a feature from each part, the feature with the lowest importance is repeatedly removed until the part's LOD reaches the target LOD (Fig. 5). If feature removal fails during this process, the feature is added to the removal failure list. It may be possible to then successfully remove a feature that failed to be removed in a previous stage if problems such as reference relationships are resolved after removing other features. Therefore, after all other features have been removed in the current stage, removal is attempted again for the features on the removal failure list. Lastly, if the user-entered LOD cannot be reached, a warning is given to the user and information is provided about the features on the removal failure list.

Feature removal methods include feature suppression and face deletion. Because feature suppression removes previously defined features, it is easy to predict changes in shape after removal. However, when a feature is removed, other features that have reference relationships with the removed feature are also removed. Face deletion is a function that removes the faces of features and expands or shrinks adjacent faces to create a closed solid. The faces of the target features are removed without regard to reference relationships between features. However, shape changes occur when the empty parts are filled in after feature removal and are difficult to predict. This study considers this by performing feature suppression first then performing face deletion if feature suppression fails. Feature suppression is considered to have failed if other features aside from the target feature are also removed. Face deletion is considered to have failed if there is at least 10% error between the changed volume after face deletion

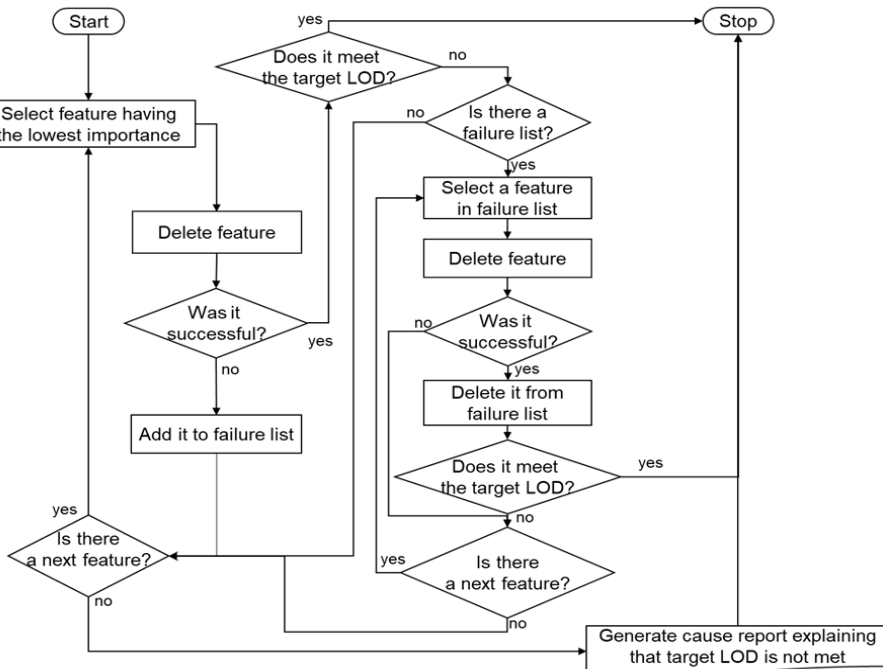

Fig. 5 Removal of less important features comprising a part model

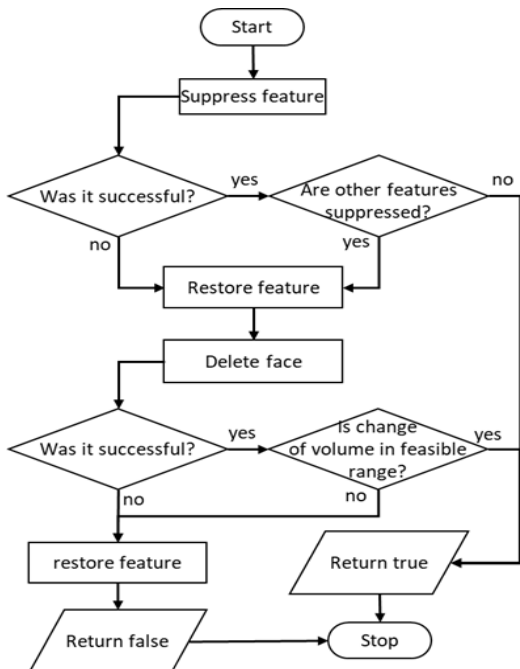

Fig. 6 Removal of feature using suppression and face deletion

and the target feature's volume. If both feature suppression and face deletion fail, feature removal is considered to have failed.

#### 4. Progressive LOD Control using Component Locking Mechanism and Determining the Permitted LOD Range

The major functions of LOD-based simplification, which is the third stage of the assembly model simplification method proposed in this study, are the component locking mechanism and the highest and lowest limits of permitted LOD. Component locking prevents additional simplification from being performed on subordinate components that have already completed simplification during the LOD-based simplification process of a higher-level component. For example, we assume that there is a higher-level component, P1, composed of components



C1, C2, and C3, and simplification has already been performed on C1 and it has been locked. If this is the case, then C1 is not affected when P1 is simplified by the LOD-based simplification method. On the other hand, if a subordinate component CC1 of the user-locked component C1 is selected and LOD-based simplification is applied, simplification is possible if CC1 is not locked. This method is more flexible than existing methods<sup>[16]</sup> that lock all subordinate components when a selected component is locked. This mechanism is applied because assembly model simplification usually performs additional individual simplification on subordinate components after determining an approximate LOD by selecting and simplifying higher-level components. Of course, components can also be unlocked according to the user's judgment during the simplification process. Fig. 7 describes the locking mechanism proposed in this study.

The highest and lowest limits of the LOD that the user can enter for each component in the LOD-based simplification stage are related to the parts to be preserved, the parts to be removed, and the small element parts in the processing stage, as well as the user-locked components in the LOD-based simplification stage. Therefore, it is necessary to calculate the highest and lowest limits of the LOD for the selected component then determine if the

user-entered LOD is within this range during the LOD-based simplification stage (Fig. 8). Eqs. (5) and (6) are used to calculate the LOD's highest and lowest limits, respectively.

$$LOD_{max} = \frac{\sum N - (\sum N_{PD} + \sum N_{LD} + \sum N_S + \sum N_R)}{\sum N} \times 100\% \quad (5)$$

$$LOD_{min} = \frac{\sum N_P - \sum N_{PD} + \sum N_L - \sum N_{LD}}{\sum N} \times 100\% \quad (6)$$

where  $\sum N_P$  is the number of features included in the parts to be preserved,  $\sum N_{PD}$  is the number of features removed from the parts to be preserved,  $\sum N_R$  is the number of features included in the parts to be removed,  $\sum N_S$  is the number of features included in the parts that are small elements,  $\sum N_L$  is the number of features included in locked parts, and  $\sum N_{LD}$  is the number of features removed from locked

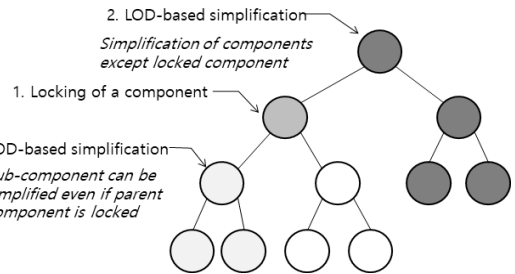

Fig. 7 Component locking mechanism

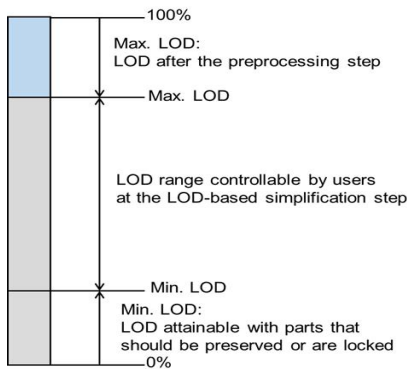
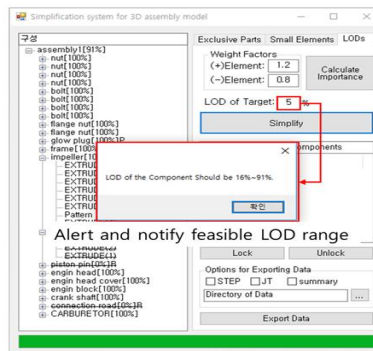

Fig. 8 Feasible LOD range of a component at the LOD-based simplification step



parts. The LOD highest limit value is the ratio of the number of features remaining after preprocessing, and the LOD lowest limit value is the ratio of the number of features that cannot be removed.

## 5. Method Implementation and Verification

A prototype system that supports the 3D CAD assembly model simplification method was developed in the form of a Siemens NX plug-in type module (Fig. 9). The C# language was used in Microsoft Visual Studio 2010 and the system's UI was implemented using a Microsoft Windows forms application. The Siemens Open API and the NX Simplification API, which was developed in a previous study<sup>[4]</sup>, were used as external libraries. The Siemens Open API was used to connect with Siemens NX and create additional menus in Siemens NX. The NX Simplification API provides a collection of basic functions required for the simplification of Siemens NX 3D CAD assembly models, such as data extraction, component selection, part and feature selection and removal, part volume calculation, etc.

A test model was created for the model simplification experiments using the developed prototype model. The test model was modeled directly

as a Siemens NX's native 3D CAD assembly by referring to two-dimensional drawings of an engine blower obtained from the Internet. This model has also been used in previous studies<sup>[13]</sup> and is composed of 21 parts. This test model includes internal parts, each of which was modeled using a variety of features.

During the experiment, the test model was simplified according to the procedure explained in Section 3.1. After preprocessing the model and calculating the importance of each feature, a user inputted the desired LOD value. The prototype module then checked whether the LOD value was within the permitted LOD range, as shown in Fig. 8. If not, the prototype module sent a warning message and guided the user to input a proper LOD value.

Fig. 10 shows the results of the experiment in which the prototype module was used to simplify the test model. This figure shows the test model's shape, LOD, file size, and the ratio of the current file size to the original file size for each simplification stage (assembly model loading, internal part removal, small element part removal, LOD-based simplification). For the comparison of file sizes for original and simplified models, they were saved in ISO 10303 STEP format and then their file sizes were compared. According to the final stage's results, the assembly model was simplified to the user-entered LOD value (22%) and the file's size was reduced to 58% of the original model's file size. The LOD was calculated based on the number of features composing a model. If features consisting of simple geometric objects such as lines and planes are removed and feature having complex geometric objects such as curves and surfaces during the simplification, the file size of a simplified model is relatively high compared to the LOD of the simplified model[22]. Notably, the final model adequately preserved the original model's overall shape characteristics. Therefore, a user of the Siemens NX system can easily simplify a 3D CAD assembly model by using the plug-in type system

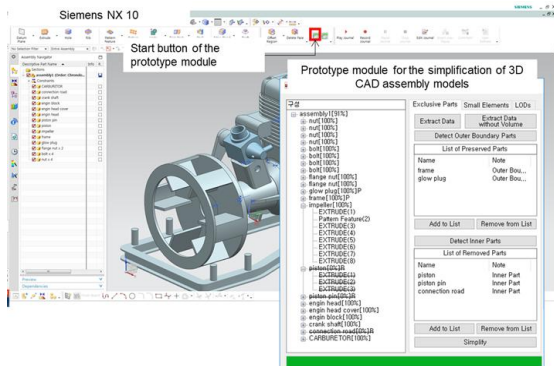





Fig. 9 Prototype simplification module for feature-based 3D assembly models

	<p>LOD=100% File size=2337 kB Size reduction ratio=100%</p>		<p>LOD=80% File size=2183 kB Size reduction ratio=93%</p>
a) Loading of a 3D CAD assembly model		b) Removal of internal and user-selected parts	
	<p>LOD=50% File size=1993 kB Size reduction ratio=85%</p>		<p>LOD=22% File size=1372 kB Size reduction ratio=58%</p>
c) Removal of small parts		d) Simplification according to a desired LOD	

**Fig. 10 Simplification result for the engine blower assembly model**

developed in this study.

## 6. Conclusions

This study proposed a technique for simplifying 3D CAD assembly models through a feature-based method. We first developed a model preprocessing method to identify outer boundaries and small elements, a method to calculate the 3D CAD assembly model LOD, a method to calculate feature importance using volume and weighting, and a method to remove features of low importance. We also proposed a method to automatically determine the highest and lowest permitted LOD limits for each component to examine the validity of the user-entered LOD and progressively control the LOD of an assembly model using the component locking mechanism. A prototype module that supports the proposed simplification method was implemented as a Siemens NX plug-in. Finally, the developed prototype model was used to experimentally simplify a 3D CAD assembly model, which verified the effectiveness

of the proposed method.

This study involved some limitations. First, the proposed method is general, but the developed prototype module is limited in that it depends on the specific commercial system, Siemens NX. In addition, the proposed simplification method is a feature-based method; thus, it cannot perform fine LOD adjustments if there is no feature information. Finally, the developed system can only be used to simplify solid models. However, actual work sites often use 3D CAD models that include both solids and surfaces. Therefore, in the future it will be necessary to study methods that simplify assembly models containing such parts.

## Acknowledgement

This research was supported by the Industrial Core Technology Development Program (Project ID: 20000725) funded by the Korea government (MOTIE), by the Plant Research Program (Project ID: 14IFIP-B091004-01) funded by the Korean

government (MOLIT), and by the Basic Science Research Program (Project ID: NRF-2019R1F1A1053542) through the National Research Foundation of Korea (NRF) funded by the Korea government (MSIT).

## References

1. Kwon, S., Kim, B. C., Mun, D. and Han, S., "Simplification of feature-based 3D CAD assembly data of ship and offshore plant equipment using quantitative metrics", *Computer-Aided Design*, Vol. 59, pp. 140-154, 2015
2. Kwon, S., Kim, B. C., Hwang, H., Mun, D. and Han, S., "Enhancement of equipment information sharing using three-dimensional computer-aided design simplification and digital catalog techniques in the plant industry", *Concurrent Engineering: Research and Applications*, Vol. 24, No. 3, pp. 275-289, 2016.
3. Thakur, A., Banerjee, A. G. and Gupta, S. K., "A survey of CAD model simplification techniques for physics-based simulation applications", *Computer-Aided Design*, Vol. 41, No. 2, pp. 65-80, 2009.
4. Yu, E. S., Lee, J., Lee, J. Y. and Mun, D., "Development of UG NX-based APIs for the simplification of 3D CAD assembly Models", *Korean Journal of Computational Design and Engineering*, Vol. 22, No. 3, pp. 284-294, 2017.
5. El-Sana, J. and Varshney, A., "Topology simplification for polygonal virtual environments", *IEEE Transactions on Visualization and Computer Graphics*, Vol 4, No. 3, pp. 133-44, 1998.
6. Date, H., Kanai, S., Kisinami, T., Nishigaki, I. and Dohi, T., "High-quality and property controlled finite element mesh generation from triangular meshes using the multiresolution technique", *Journal of Computing and Information Science in Engineering*, Vol. 5, No. 4, pp. 266-276, 2005.
7. Valette, S., Kompatsiaris, I. and Chassery, J., "Adaptive Polygonal Mesh Simplification With Discrete Centroidal Voronoi Diagrams", *Proceedings of 2nd International Conference on Machine Intelligence*, pp. 655-662, 2005.
8. Foucault, G., Cuilliere, J. C., Francois, V., Leon, J. and Maranzana, C. R., "Adaptation of CAD model topology for finite element analysis", *Computer-Aided Design*, Vol. 40, No. 2, pp. 176-96, 2008.
9. Kim, B. C., and Mun, D., "Stepwise volume decomposition for the modification of B-rep models", *International Journal of Advanced Manufacturing Technology*, Vol. 75, No.9-12 pp. 1393-403, 2014.
10. Seo, J. H., Song, Y. J., Kim, S. C., Lee, K. W., Choi, Y. and Chae, S. W., "Wrap-around Operation for Multi-resolution CAD Model", *Computer-Aided Design & Applications*, Vol. 2, No. 1-4, pp. 67-76, 2005
11. Kang, Y., Kim, B. C., Mun, D. and Han, S., "Method to simplify ship outfitting and offshore plant equipment three-dimensional (3-D) computer-aided design (CAD) data for construction of an equipment catalog", *Journal of Marine Science and Technology*, Vol. 19, No. 2, pp. 185-196, 2014.
12. Lee, S. H., and Lee, K., "Simultaneous and incremental feature-based multiresolution modeling with feature operations in part design", *Computer-Aided Design*, Vol. 44, No. 5, pp. 457-83, 2012.
13. Kwon, S., Kim, B. C., Mun, D. and Han, S., "Graph-based Simplification of Feature-Based Three-Dimensional Computer-Aided Design Models for Preserving Connectivity", *Journal of Computing and Information Science in Engineering*, Vol. 15, No. 3, pp. 90-103, 2015.
14. Reddy, M., "Specification and evaluation of level of detail selection criteria", *Virtual Reality*,

Vol. 3, No. 2, pp. 132-143, 1998.

15. Kim, B. C. and Mun, D., "Feature-based simplification of boundary representation models using sequential iterative volume decomposition", *Computers and Graphics*, Vol. 38, pp. 97-107, 2014.
16. Kwon, S., Kim, B. C., Mun, D. and Han, S., "User-assisted integrated method for controlling level-of-detail of large-scale B-rep assembly models", *International Journal of Computer Integrated Manufacturing*, Vol. 31, No. 9, pp. 881-891, 2018.
17. Owen J., *STEP: An Introduction*, 2edition. Information Geometers, 1997.
18. ISO, *ISO 14306:2017, Industrial automation systems and integration — JT file format specification for 3D visualization*, Geneva, Switzerland: International Organization for Standardization (ISO), 2017.
19. Kanai, S., Iyoda, D., Endo, Y., Sakamoto, H. and Kanatani, N., "Appearance preserving simplification of 3D CAD model with large-scale assembly structures", *International Journal on Interactive Design and Manufacturing*, Vol. 6, No. 3, pp. 139-154, 2012.
20. Yu, J. F., Xiao, H., Zhang, J., Cheng, H., Xin, B., "CAD model simplification for assembly field", *International Journal of Advanced Manufacturing Technology*, Vol. 68, No. 9-12, pp. 2335-2347, 2013.
21. Koo, S. and Lee, K., "Wrap-around operation to make multi-resolution model of part and assembly", *Computers & Graphics*, Vol. 26, No. 5, pp. 687-700, 2002.
22. Kwon, J., Mun, D., Kim, B.C., Han, S., "Feature shape complexity: A new criterion for the simplification of feature-based 3D CAD models", *International Journal of Advanced Manufacturing Technology*, Vol. 88, No. 5, pp 1831 - 1843, 2017.