



## Original Article

## Dose rate measurement of Leksell Gamma Knife Perfexion using a 3D printed plastic scintillation dosimeter

Sangmin Lee <sup>a</sup>, Tae Hoon Kim <sup>a</sup>, Jae Young Jeong <sup>a</sup>, Jaebum Son <sup>a</sup>, Dong Geon Kim <sup>a</sup>, Gyu-Seok Cho <sup>b</sup>, Sang Hyoun Choi <sup>b</sup>, Hyun-Tai Chung <sup>c</sup>, Yong Kyun Kim <sup>a,\*</sup><sup>a</sup> Department of Nuclear Engineering, Hanyang University, Seoul, Republic of Korea<sup>b</sup> Research Team of Radiological Physics & Engineering, Korea Institute of Radiological and Medical Science, Seoul, Republic of Korea<sup>c</sup> Department of Neurosurgery, Seoul National University College of Medicine, Seoul, Republic of Korea

## ARTICLE INFO

## Article history:

Received 20 January 2020

Received in revised form

13 March 2020

Accepted 21 March 2020

Available online 24 March 2020

## Keywords:

Plastic scintillator

3D printing

Gamma Knife

Dosimeter

Treatment plan

## ABSTRACT

In recent years, 3D printing technology has received significant research attention. Additionally, 3D printing technology is being applied to study radiation dosimeters of various materials. In this study, a plastic scintillator for 3D printing was developed in a laboratory and used to manufacture a plastic scintillation dosimeter (PSD) with a shape identical to that of the ionization chamber PTW31010. The 16-mm beam of Gamma Knife® Perfexion™ was irradiated to derive the absorbed dose rates of the PSD and PTW31010; they were subsequently compared with the dose rates of the treatment plan. The differences in the dose rates of the Gamma Knife treatment plan and the absorbed dose rates of PTW31010 were within 0.87%. The difference between the dose rates of the Gamma Knife treatment plan and the absorbed dose rates of the PSD were within 4.1%. A linear fit of the absorbed dose rates of four shots involving different dose rates and irradiation angles yielded an adjusted R-square value exceeding 0.9999. A total of 10 repeated measurements were conducted for the same shot to confirm its reproducibility, with a relative error of 0.56%.

© 2020 Korean Nuclear Society, Published by Elsevier Korea LLC. This is an open access article under the CC BY-NC-ND license (<http://creativecommons.org/licenses/by-nc-nd/4.0/>).

## 1. Introduction

Currently, 3D printing is one of the key technologies enabling the fourth industrial revolution. This technology is being employed and researched in several industries such as machinery, aviation, automobiles, and medical fields. In the medical field, several studies have employed 3D printing to create replicas of human organs, tissues, and phantoms [1–6]. Studies have also attempted to construct radiation detectors by using 3D printing, for medical applications. In previous studies, 3D dosimeters composed of various materials were fabricated, and dose distributions were measured using these dosimeters [7,8]. Our research team has developed a plastic scintillator that can be 3D printed [9,10]. Although its performance is lower than that of a commercial plastic scintillator constructed via thermal polymerization, it is being improved through continuous material research. In addition, it is expected that its production time can be shortened by and its

production method can be customized and personalized, thereby enabling its application to various fields.

The gamma knife is a stereotactic radiosurgery equipment that is widely used for the treatment of intracranial and peripheral diseases. The Elekta Leksell Gamma Knife® (LGK) Perfexion™ Model (PFX) contains 192 cobalt-60 sources that are arranged in an eight-sector crown-shaped collimator. The beam irradiated from LGK PFX is a combination of 4, 8 and 16 mm beams formed in each sector. Radiosurgery equipment, including gamma knives, are provided with a treatment plan system (TPS) to ensure that the radiation is only focused on the tumor volume and to minimize its effect on normal tissues. Currently, TRS 483 provides ionization chambers as reference dosimetry that can be used to calibrate gamma knives. Various studies have focused on the verification of the treatment doses of a gamma knife [11–13].

In this study, a plastic scintillation dosimeter (PSD) was fabricated using 3D printing technology. It was manufactured in a shape identical to that of PTW31010 (PTW-Freiburg, Germany), which is one of the ionization chambers used for the calibration of gamma knife doses. The absorbed dose rate was measured under gamma knife beam irradiation and compared with the gamma knife

\* Corresponding author.

E-mail address: [ykkim4@hanyang.ac.kr](mailto:ykkim4@hanyang.ac.kr) (Y.K. Kim).

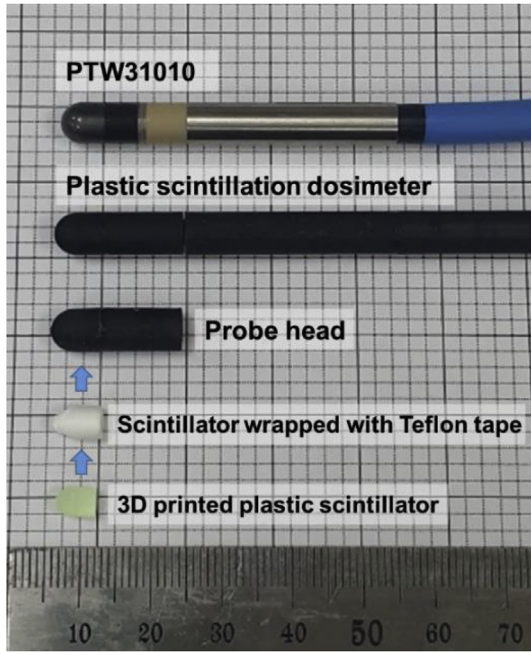

Fig. 1. Appearance of the probe head component, plastic scintillation dosimeter, and PTW31010.

treatment plan. Dose rate dependence, angle dependence, and reproducibility were identified to validate the measurement system of the PSD.

2. Materials and methods

2.1. Fabrication of the PSD

The PSD with a shape identical to that of PTW31010 (PTW-Freiburg, Germany) was fabricated using a DLP 3D printer (Asiga Pico2HD, Australia and custom-made product). The plastic scintillator was printed so as to match the sensitive volume (0.125 cm<sup>3</sup>) of PTW31010, using the scintillator resin developed in our laboratory for 3D printing. The resin was composed of BPA(EO)15DMA (acrylic monomer), PPO (primary dye), ADS086BE (wavelength shifter) and TPO (photoinitiator). The plastic scintillator was fabricated by curing a 0.15 mm thick layer for 20 s and stacking them sequentially. The 3D printed plastic scintillator has a light output of 2409 ± 37 photons/MeV and a density of 1.157 g/cc [10]. The outer appearance of the dosimeter was manufactured using a black commercial 3D printer resin (Carima, Korea). The dosimeter comprised of two parts: a probe head into which the scintillator

Table 1  
Calibration factor of PTW31010 and scintillator samples.

Measuring device	Calibration factor (Gy/nC)
PTW31010	$2.905 \times 10^{-1}$
Scintillator (Sample 1)	$-1.293 \times 10^{-4}$
Scintillator (Sample 2)	$-5.471 \times 10^{-5}$
Scintillator (Sample 3)	$-7.970 \times 10^{-5}$
Scintillator (Sample 4)	$-6.317 \times 10^{-5}$

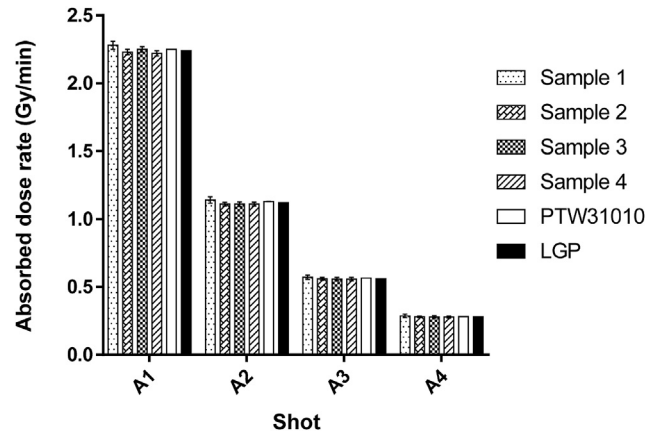

Fig. 3. Absorbed dose rates for gamma knife shots A1–A4 of PTW31010 and the plastic scintillator samples.

entered and a probe to fix the optical fiber. The probe head can be detached from the probe. The scintillator was wrapped with Teflon tapes to focus the generated scintillation lights. Four scintillator samples were prepared, and the same number of probes and probe heads were fabricated. Fig. 1 depicts the appearance of PTW31010 and the fabricated PSD.

The light pipe that transmits scintillation light to the photodetector was composed of pure silica optical fiber FP200URT (Thorlabs, USA) and had a core diameter of 200 μm. The photodetector used for the measurement was H7422-40 PMT (Hamamatsu Photonics, Japan), which is equipped with a cooler to maintain its internal temperature. The current from PMT was recorded using an electrometer (Model 6517B, Keithley, USA). The overall schematic of the measurement system is shown in Fig. 2.

2.2. Cerenkov light subtraction

To eliminate the Cerenkov light generated in the optical fiber upon irradiation, a black probe head without a scintillator was manufactured. First, the measurement system was combined with

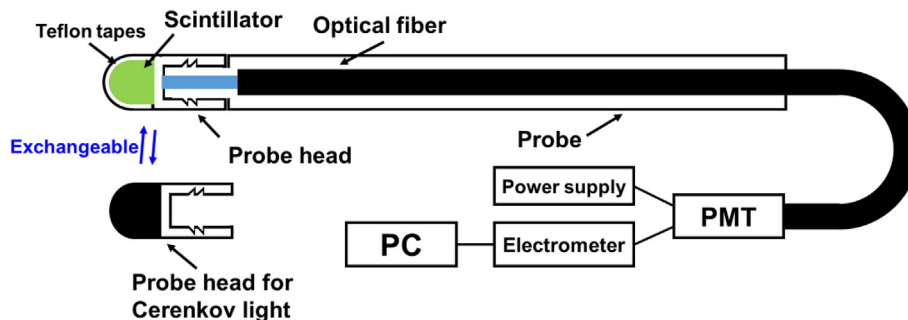

Fig. 2. Schematic diagram of the plastic scintillation dosimeter measurement system.

**Table 2**  
Data of gamma knife shots.

Shot	Isocenter (mm)			Collimator [sectors 1–8]								Dose rate at focus (Gy/min)	
	X	Y	Z	1	2	3	4	5	6	7	8		
A1	100.0	100.0	100.0	16	16	16	16	16	16	16	16	16	2.240
A2	100.0	100.0	100.0	16	B	16	B	16	B	16	B	B	1.120
A3	100.0	100.0	100.0	16	B	B	B	16	B	B	B	B	0.560
A4	100.0	100.0	100.0	16	B	B	B	B	B	B	B	B	0.280

the scintillator probe head and irradiated using a radiation beam, to record the total current ( $I_{total}$ ) measured together with the scintillation light and the Cerenkov light. Subsequently, the scintillator probe head was replaced with a black probe head, and it was irradiated using the same radiation beam to measure the current of the Cerenkov light ( $I_{Ceren}$ ). Finally, the net current ( $I_{net}$ ), excluding the Cerenkov light, was calculated using Equation (1).

$$I_{net} = I_{total} - I_{Ceren} \quad (1)$$

The background currents of the total current ( $I_{total}$ ) and the Cerenkov light current ( $I_{Ceren}$ ) were eliminated prior to calculating the net current ( $I_{net}$ ).

### 2.3. Calibration factor

The PSD was calibrated at the Korean Institute of Radiological & Medical Sciences (KIRAMS), a secondary standard dosimetry laboratory (SSDL) that provides calibration of dosimetry equipment. The ionization chamber PTW31010 has been previously calibrated at KIRAMS. Signals of the PSD under the reference condition were measured for the Co-60 beam, and the calibration factor ( $N_{ref} = N_{D,w}$ ) was derived using Equation (2).

$$\dot{D}_{ref} = N_{ref} \times I_{net}^{ref} \quad (2)$$

where  $\dot{D}_{ref}$  is the dose rate at the SSDL reference condition for the Co-60 beam, and  $I_{net}^{ref}$  is the net current measured under the same condition. The calibration factors for four scintillator samples were obtained, as listed in Table 1.

### 2.4. Dose rate measurement of the Gamma Knife

The output measurements of PTW31010 and PSD were obtained using LGK PFX, at the Gamma Knife Center of Seoul National University Hospital. The measuring device was placed at the center of Solid Water Leksell Gamma Knife® Dosimetry Phantom (Elekta Instruments AB, Stockholm, Sweden), and a 16-mm beam was irradiated at the isocenter point ( $X = 100$ ,  $Y = 100$ , and  $Z = 100$ ). The output was measured by irradiating four shots (A1–A4) with different dose rates (as presented in Table 2). The beam was irradiated only in the sector selected according to the dose rate of the 16-mm beam, and the remaining sectors were blocked. All

measurements were conducted for 100 s at intervals of 0.1 s. A 60 s measurement value was selected such that it eliminated the first 30 s and the last 10 s measurement values. The absorbed dose rate ( $\dot{D}_{LGK}$ ) was determined by multiplying the measured net current ( $I_{net}^{LGK}$ ) with the calibration factor ( $N_{ref}$ ), as shown in Equation (3).

$$\dot{D}_{LGK} = N_{ref} \times I_{net}^{LGK} \quad (3)$$

In addition, ten measurements were conducted for shot A1 to confirm the reproducibility of the system. After one measurement, the probe head was removed from the probe and once again reattached for the next measurement.

## 3. Results and discussion

### 3.1. Differences in the treatment plan dose rates

The absorbed dose rates of PTW31010 and PSD were compared with the dose rate of Leksell GammaPlan® (LGP), which is the gamma knife treatment planning system. The absorbed dose rates for Gamma Knife shots of PTW31010 and plastic scintillator samples are listed in Table 3 and depicted in Fig. 3. For shots A1–A4, the difference between the dose rates of PTW31010 and LGP was within 0.87%. The maximum uncertainty of each measurement was 0.02%. As the calibration was performed using PTW31010, which is an ionization chamber that is suitable for the reference dosimetry of the gamma knife presented in TRS 483, it is evident there is minimal error with respect to the dose rates of LGP.

Furthermore, for shots A1–A4, the differences between the mean absorbed dose rates of the scintillator samples and LGP were within 4.1%. As compared to LGP, lower dose rates were obtained, and the differences between the scintillator samples were within 1.1%. The uncertainty for each measurement ranged from 0.86 to 4.31%, and the lower the dose rate of the shots, the greater was the uncertainty. The difference between the source intensity and the geometry between LGK PFX and Theratron 780 used to calibrate the PSD is considered as a major factor contributing to this under response. The lower the irradiated dose rate, the lesser is the light emitted from the scintillator and the greater is the background ratio. Thus, calibration in low dose rates may produce different results as compared to that in high dose rates, for small fields. Generally, plastic scintillators are not significantly affected by small

**Table 3**  
Absorbed dose rate of PTW31010 and the plastic scintillator in comparison with LGP. It was measured once for each shot and the results were calculated with 60 s of data measured in 0.1 s.

Shot	LGP (Gy/min)	Absorbed dose rate (Gy/min)						Difference (vs LGP)	
		PTW31010	Plastic scintillator				Mean	PTW31010	Scintillaor
			Sample 1	Sample 2	Sample 3	Sample 4			
A1	2.240	2.254 ± 0.004	2.187 ± 0.029	2.143 ± 0.018	2.166 ± 0.020	2.138 ± 0.019	2.159 ± 0.023	0.64%	−3.7%
A2	1.120	1.128 ± 0.005	1.092 ± 0.022	1.072 ± 0.013	1.068 ± 0.016	1.069 ± 0.014	1.075 ± 0.011	0.68%	−4.08%
A3	0.560	0.565 ± 0.007	0.549 ± 0.015	0.537 ± 0.010	0.535 ± 0.011	0.535 ± 0.011	0.539 ± 0.007	0.82%	−3.79%
A4	0.280	0.282 ± 0.000	0.274 ± 0.012	0.269 ± 0.006	0.269 ± 0.009	0.268 ± 0.008	0.270 ± 0.003	0.87%	−3.58%

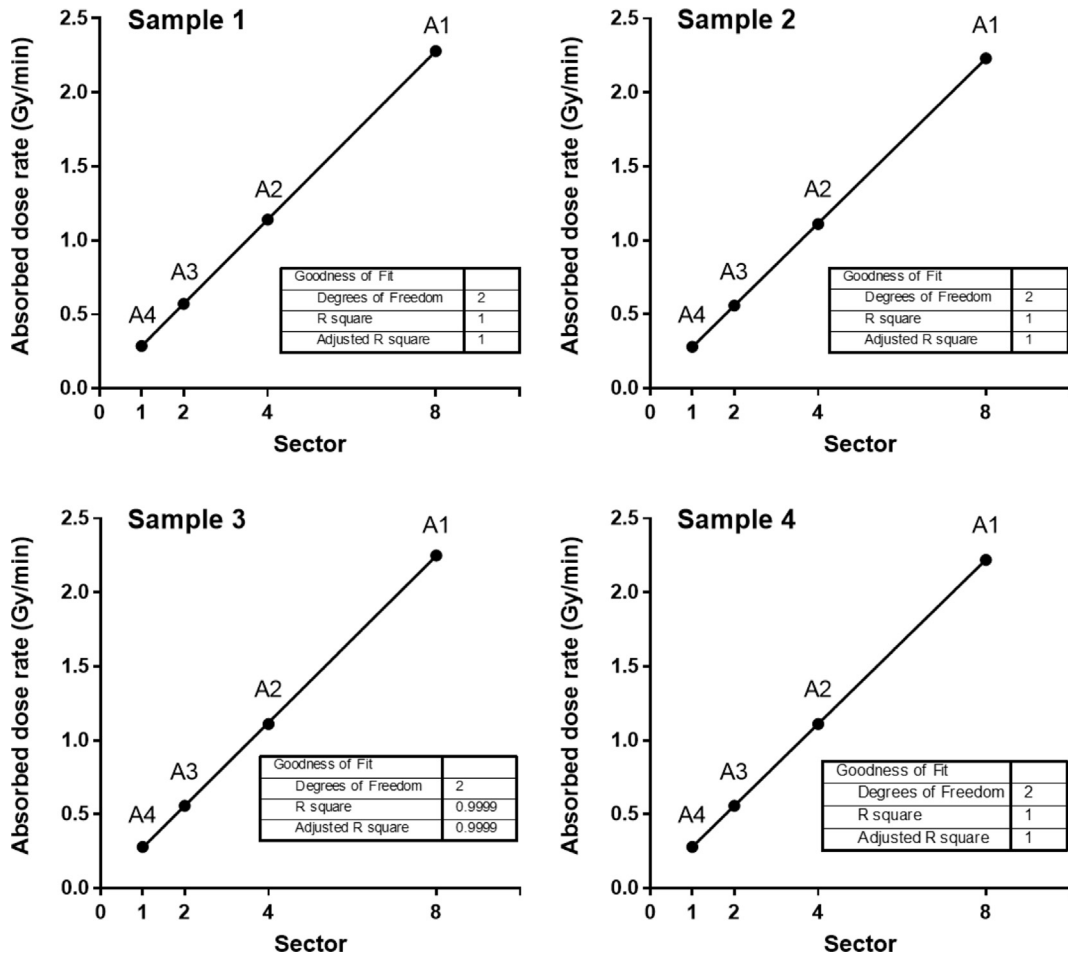

Fig. 4. Absorbed dose rates and linear fittings of plastic scintillator samples for gamma knife shots A1–A4.

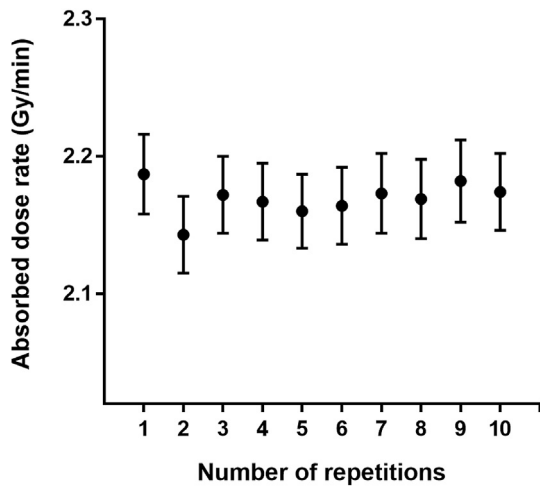

Fig. 5. Results of repeated measurements of the plastic scintillator sample 1 for gamma knife shot A1.

temperature differences [14]; hence, the light output of the 3D printed plastic scintillator was not corrected for the temperature difference between the water phantom used in the calibration environment and the Solid Water Lequesell Gamma Knife® Dosimetry Phantom. However, the temperature dependency of this scintillator may have slightly affected the amount of light as this

Table 4

Repeated measurement of scintillator sample 1 for shot A1.

Number of repetitions	Shot A1	Relative error
1	2.187 ± 0.029	0.56%
2	2.143 ± 0.028	
3	2.172 ± 0.028	
4	2.167 ± 0.028	
5	2.160 ± 0.027	
6	2.164 ± 0.028	
7	2.173 ± 0.029	
8	2.169 ± 0.029	
9	2.182 ± 0.030	
10	2.174 ± 0.028	
Mean	2.169 ± 0.012	–

phenomenon has not been thoroughly studied thus far. Additionally, it is possible that human errors were introduced during the repetitive process of connecting and disconnecting the probe head. Although the absorbed dose rates of scintillators differ from those of LGP, the results are considered to be meaningful because the differences between the scintillator samples were consistent.

### 3.2. Dose rate and angular dependencies

The absorbed dose rates for shots A1–A4 are plotted on a graph with respect to the dose rate ratio of the shots; subsequently, linear

fitting was performed. As shown in Fig. 4, the adjusted R-square values of the linear fits of all four scintillator samples exceeded 0.9999, indicating a complete linearity of the dose rates. In addition, shots A1–A4 required different number of collimator sectors in accordance with the dose rate. Hence, each shot is a beam combination irradiated at different angles. The results presented in Fig. 5 also depict the linearity of the measurement with respect to the angle.

### 3.3. Reproducibility

The results of repeated measurements for shot A1 of scintillator sample 1 are listed in Table 4 and depicted in Fig. 5. The relative error of the repeated measurements is 0.56%, and the uncertainty of each measurement was within 1.35%. Moreover, it is evident that the reproducibility of the measurement is ensured for the modular probe head system. The uncertainty for shot A1 of the other samples did not exceed 1%, and only sample 1 had an early 1% value. This is believed to be the result of human errors introduced when manufacturing the scintillators, wrapping them with Teflon tape, and placing them in the probe head.

## 4. Conclusion

A PSD was fabricated via 3D printing, and the system was validated based on a gamma knife, which is a stereotactic radiosurgery device. The difference between the absorbed dose rates of PSD and the dose rates of the treatment plan was found to be less than 4.1%. This result is attributed to the differences in the source intensity and geometry between the calibration environment and the gamma knife. To improve this, it may be necessary to propose a new calibration method. Furthermore, independence of the dose rates and beam irradiation angles of PSD was identified. Reproducibility was also assured with a relative error of 0.56% during the repeated measurements. The future development of additional precise calibration methods is expected to enable therapeutic dose measurements, using plastic scintillators larger than those used in commercial plastic dosimeters.

### Declaration of competing interest

The authors declare that they have no known competing financial interests or personal relationships that could have appeared to influence the work reported in this paper.

### Acknowledgements

This work was supported by the National Research Foundation

of Korea (NRF) grant funded by the Korea government (MSIT) (No. NRF-2016M2A2A6A03912636).

## Appendix A. Supplementary data

Supplementary data to this article can be found online at <https://doi.org/10.1016/j.net.2020.03.021>.

## References

- [1] A. Shafiee, A. Atala, Printing technologies for medical applications, *Trends Mol. Med.* 22 (2016) 254–265.
- [2] D. Mitsouras, P. Liacouras, A. Imanzadeh, A.A. Giannopoulos, T. Cai, K.K. Kumamaru, E. George, N. Wake, E.J. Caterson, B. Pomahac, V.B. Ho, G.T. Grant, F.J. Rybicki, Medical 3D printing for the radiologist, *Radiographics* 35 (2015) 1965–1988.
- [3] C.N. Ionita, M. Mokin, N. Varble, D.R. Bednarek, J. Xiang, K.V. Snyder, A.H. Siddiqui, E.I. Levy, H. Meng, S. Rudin, Challenges and limitations of patient-specific vascular phantom fabrication using 3D Polyjet printing, in: *Medical Imaging 2014: Biomedical Applications in Molecular, Structural, and Functional Imaging*, vol. 9038, International Society for Optics and Photonics, 2014.
- [4] L. Martin, K. Tomas, K. Cameron, F. Rick, L. Peta, S. Aleksandar, B. Milan, Additive manufacture of custom radiation dosimetry phantoms: an automated method compatible with commercial polymer 3D printers, *Mater. Des.* 86 (2015) 487–499.
- [5] R. Mayer, P. Liacouras, A. Thomas, M. Kand, L. Lin, C.B. Simone II, 3D printer generated thorax phantom with mobile tumor for radiation dosimetry, *Rev. Sci. Instrum.* 86 (2015), 074301.
- [6] K.A. Abdullah, M.F. McEntee, W. Reed, R.L. Kench, Development of an organ-specific insert phantom generated using a 3D printer for investigations of cardiac computed tomography protocols, *J. Med. Radiat. Sci.* 65 (2018) 175–183.
- [7] S.T. Bache, T. Juang, M.D. Belley, B.F. Koontz, J. Adamovics, T.t. Yoshizumi, D.G. Kirsch, M. Oldham, Investigating the accuracy of microstereotactic-body-radiotherapy utilizing anatomically accurate 3D printed rodent-morphic dosimeters, *Med. Phys.* 42 (2015) 846–855.
- [8] T. Hashimoto, F. Sato, S. Tamaki, S. Kusaka, H. Miyamaru, I. Murata, Fabrication of radiophotoluminescence dosimeter with 3D-printing technology, *Radiat. Meas.* 124 (2019) 141–145.
- [9] S. Lee, J. Son, D.G. Kim, J. Choi, Y.K. Kim, Characterization of plastic scintillator fabricated by UV LED curing machine, *Nucl. Instrum. Methods Phys. Res. A* 929 (2019) 23–28.
- [10] J. Son, D.G. Kim, S. Lee, J. Park, Y.K. Kim, Improved 3D printing plastic scintillator fabrication, *J. Kor. Phys. Soc.* 73 (2018) 887–892.
- [11] P. Papagiannis, P. Karaiskos, M. Kozicki, J.M. Rosiak, L. Sakelliou, P. Sandilos, I. Seimenis, M. Torrens, Three-dimensional dose verification of the clinical application of gamma knife stereotactic radiosurgery using polymer gel and MRI, *Phys. Med. Biol.* 50 (2005) 1979.
- [12] J. Yuan, S.S. Lo, Y. Zheng, J.W. Sohn, A.E. Sloan, R. Ellis, M. Machtay, B. Wessels, Development of a Monte Carlo model for treatment planning dose verification of the Leksell Gamma Knife Perfexion radiosurgery system, *J. Appl. Clin. Med. Phys.* 17 (2016) 190–201.
- [13] A. Hornbeck, T. Garcia, M. Cuttat, C. Jenny, Absolute calibration of the Gamma Knife® Perfexion™ and delivered dose verification using EPR/alanine dosimetry, *Med. Phys.* 41 Part1 (2014), 061708.
- [14] E.B. Podgorsak, *Radiation Oncology Physics*, International Atomic Energy Agency, Vienna, 2005, pp. 123–271.