



Review Article

Control of accidental discharge of radioactive materials by filtered containment venting system: A review

Manisha Bal ^{a,*}, Remya Chinnamma Jose ^a, B.C. Meikap ^{a,b}^a Department of Chemical Engineering, Indian Institute of Technology (IIT), Kharagpur, West Bengal, 721302, India^b Department of Chemical Engineering, School of Engineering, Howard College, University of Kwazulu-Natal, Durban, South Africa

ARTICLE INFO

Article history:

Received 8 August 2018
 Received in revised form
 7 December 2018
 Accepted 12 January 2019
 Available online 21 January 2019

Keywords:

FCVS
 Radioactive material
 Nuclear power plant accident

ABSTRACT

Radioactive materials are released from the molten core into the containment at the time of a severe accident in a nuclear power plant (NPP). Filtered containment venting system is a popular and effective safety measure installed to obstruct the uncontrolled escape of radioactive materials due to the over pressurization of the containment. Different designs of filtered containment venting system (FCVS) are available today, each being the result of extensive research and development varying in one way or the other. This paper gives an elaborate description of the different types of FCVS currently being used, the current usage status in over 17 countries and the legislations regarding it. The recent researches being carried out in this field has also been discussed in detail. This present paper focuses on the critical review of existing FCVS, reports the challenges faced by it and highlights the potential developments to overcome the difficulties.

© 2019 Korean Nuclear Society, Published by Elsevier Korea LLC. This is an open access article under the CC BY-NC-ND license (<http://creativecommons.org/licenses/by-nc-nd/4.0/>).

1. Introduction

In the history of nuclear power plants, while there have been numerous catastrophes, three major accidents have been reported, namely, Three Mile Island (1979), Chernobyl (1986) and the recent Fukushima (2011). The crucial reasons for NPP accidents are reactor core melt down, release of radioactive isotopes, unexpected external events that disrupt the normal functioning of the plant & equipment failure. Fukushima Daiichi has by far been the worst NPP accident reported. In terms of understanding its effect, a large scale earthquake in March 2011 generated a 45 ft high tsunami that stroked the Fukushima NPP plants, resulting in the blackout of all the units in the power station [1]. In fact all the reactors were scrambled by the station blackout but the emergency core coolant system failed to cool the core and remove the decay heat due to which the core heated up and melted. The molten core generated steam and hydrogen which caused over pressurization of the containment. Hydrogen combustion resulted in explosion of two units leading to the release of radioactive materials into the environment which had a huge impact on the society. In nuclear power plants, when the core starts to melt, the reactor containment could

be drastically affected by the excessive pressure caused by the heat formation inside the containment over a long time. Once the primary containment fails the secondary containment is usually unable to retain radioactive material inside it since the secondary containment is not as protective as the primary containment. Due to this accident, iodine-131, considered to be a major harmful component, was released into the atmosphere. Radioactive iodine is toxic for normal human life as it causes overactive thyroid and may engender thyroid cancer [2]. This disaster led to reinforce the necessity of further improvements regarding safety in nuclear power plant designs. To reduce the risks generated by severe NPP accidents which occur due to over pressurization and emission of fatal elements, filtered containment venting system (FCVS) can be incorporated in NPPs as a Severe Accident Mitigation Method (SAMM). FCVS is a system that retains the fission products and allows the release of excess pressure and can also remove decay heat during the time of pressure build up in case of a NPP accident. It avoids the rupture of the containment caused by the build-up of pressure by passing the vented exhaust through a scrubber filter, by controlling the discharge of fission products it protects human life inside and nearby the plant and eases the task of the emergency teams. By employing cooling provisions it removes the decay heat and by timely venting reduces H₂ accumulation and explosion risk. FCVS are generally used in severe accidents belonging to the category of overall applied SAM strategy for PWRs (Pressurized Water

* Corresponding author.

E-mail addresses: chemmanisha1@iitkgp.ac.in, chemmanisha1@gmail.com (M. Bal).

Reactors) and BWRs (Boiling Water Reactors). But they are also used in design-basis accidents for some pressurized heavy water reactors (CANDUs) [3]. Several countries have already initiated the process of modifying their nuclear power plants to FCVS. Switzerland, Finland, France, Germany and Sweden have previously installed FCVS in their operating nuclear power plants during 1980–1990. Subsequently Netherlands, Bulgaria, China and Canada started to modify their PWRs, VVERs (Water-Water Energetic Reactors) and HPWRs (Pressurized Heavy Water Reactors) type nuclear power plants during 1990–2011. So the incident in Fukushima Daiichi in March 2011 resulted in the inspection and review of NPP safety worldwide and this instilled a clear awareness of installing FCVS in every nuclear power plant [4].

The primary intention of this paper is on discussing existing technologies of filtered containment venting system and carrying out a comparative study on them. It also identifies the FCVS implemented in different countries and highlights the legislations regarding it. The paper presents a critical review on the existing technology, specifies the current challenges and mentions the improvements that can be done in this respect.

2. Types of filtered containment venting systems

Aim of a FCVS is to maintain containment integrity, control the excessive pressure generated inside the containment and retain the airborne activity of vented gases efficiently by means of controlled venting with the help of a filtration system and preserve the containment function despite the severity of the accident. Venting also aids in removing decay heat and minimizes H_2 risk. By the release of steam, air and non condensable gases like H_2 into the atmosphere from the filtration system installed on the vent lines, the tragic containment failure can be prevented. In comparison with its alternatives like hardened vents and severe accident confinement strategies, FCVS extends higher certainty on regulation and permits regular implementation. Hence FCVS plays a crucial role in controlling severe accidents and is essential to preserve the environment and human life and minimize on and off site contamination. Filtered containment venting system was introduced by AREVA [5]. FCVS has DF of 1000 for aerosol and more than 200 for iodine. It has two staged processes, i.e. high speed venturi scrubber and the filter. All components are placed in the pressure vessel and controlled under sliding pressure conditions.

2.1. High speed sliding pressure venturi (HSSPV) scrubber

This high speed sliding pressure venturi scrubber was developed by SIEMENS-AREVA and installed in most of German, Finland and other European countries' NPPs. AREVA provides FCVS with a combined two staged process, the benefit of HSSPV (wet stage) with an efficient deep-bed fibre filter (dry stage) is made use of. The components are installed in a pressure vessel and operate in sliding pressure conditions thus leading to a compact system. The venturi scrubber unit is controlled at a pressure approximately equal to the pertaining confinement pressure. It is connected with the containment either by an isolation valve with a rupture disc or two isolation valves and a venting line. Whenever the pressure exceeds an approximate of 50 kN/m^2 , the rupture disc opens in the discharge line followed by the filtered vent gas entry into the venturi scrubber and gets consumed into a pool of water [6]. When the gas passes through the throat, gas flow produces suction which causes liquid water to be entrained with it and forms droplets. High interaction of water and gas occurs in the throat. Large amount of iodine is removed in the venturi scrubber because of the absorption of iodine in the scrubbing liquid. In addition with caustic soda, other additives in water increase the iodine scrubbing in the pool of

water. Small amounts of aerosols and liquid droplets contained in the ejector of venturi scrubber are removed from the gas by the droplet separation unit and a micro-aerosol filter at the downstream. Water droplets are captured and discarded in the first part of the filter unit. The second part of the filter unit captures the aerosol particles which are very small to retain by any other scrubber or droplet separator devices [6]. An orifice plate is kept downstream of the metal fibre filter section. The gas in the downstream is expanded to atmospheric pressure while the filtration process is operated close to containment pressure. This orifice plate regulates the gas at a high speed inside the venturi section and at low speed at the metal fibre filter section. Hence it acts as a passive speed controller. The new FCVS Plus is the extension of the existing FCVS integrated with a passive superheating module and a molecular sieve (I-CATCH). As a result, the retention of organic and elemental iodine is significantly increased and permits a modular design. The AREVA FCVS significantly reduces the risk of clogging in the dry stage as majority of the aerosols are contained in the wet stage. The integration of the scrubber with a downstream droplet separation permits a dry gas condition for the downstream metal fibre fine aerosol filtration stage hence avoiding wet operation of the metal fibre filter sections ergo ensuring a reliable operation. The dry stage significantly reduces possible aerosol and iodine re-volatilization effects. The heat of more than 99% of the isotopes is absorbed by the scrubber liquid in the wet stage where it is trapped. This facilitates passive cooling and temperature control by evaporation. Thus the heat transfer from the FCVS to the atmosphere is drastically minimized which is crucial in SBO (station blackout) scenarios where the heating, venting and air condition (HVAC) would probably be out of order. The residual isotopes (less than 1%) trapped in the second stage is very unlikely to attain self-ignition temperature at hot spots inside this stage as the amount is very low. Flow diagram of the AREVA filtered containment venting system is shown in Fig. 1. Different Filtered containment venting system developed by AREVA is shown in Table 1.

2.2. CCI filtered containment venting system

CCI filtered containment venting system was developed by SULZER CCI (IMI CCI nuclear) together with the Swiss "Paul Scherrer Institute" and installed in some Swiss NPPs [4]. This system includes an inlet basket inside the containment, inlet piping between the filter vessel and containment, containment isolation valves,

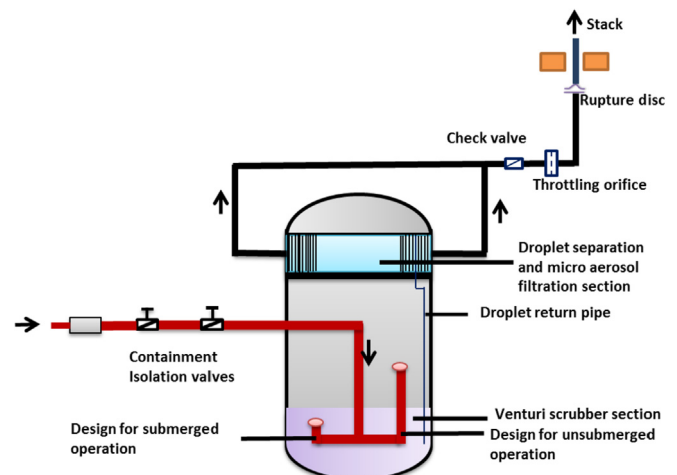

Fig. 1. Principle flow diagram of the AREVA filtered containment venting system [6].

Table 1
Different Filtered containment venting system developed by AREVA [5].

| | FCVS Plus | FCVS Standard | FCVS Basic | I-Catch |
|-------------------------------------|-------------------------------------------------------------------------|-----------------------------------------------------------|-------------------------------------------------|--------------------------------------------------------------------------------|
| Filtration stages | High-velocity venturi scrubber Metal fibre filter Molecular sieve | High-velocity venturi scrubber Metal fibre filter – | High-velocity venturi scrubber Demister – | N/A N/A Passive superheating and molecular sieve stage (I-Catch process) |
| Decontamination factors (DF) | | | | |
| Fine aerosols | >10,000 | >10,000 | >100 | – |
| Elemental iodine | >1000 | >200 | >200 | – |
| Organic iodine | >10-1000 | ~5 | ~5 | >10-1000 |

auxiliary systems, instrumentation and control systems, filter vessel and clean gas piping. CCI filter vessel was made of a stainless steel vessel and has a three staged filtration system. Water pool section of a wet scrubber is stage-1, stage-2 is used for mixing elements and acts as a recirculation zone and gas space above the wet scrubber. Stage-3 is a three staged moisture separator. In stage 1, the wet scrubber removes the particulate effluents emitted from the containment with high efficiency. The contaminated gas moves through a large number of nozzles located inside a riser which is enclosed by an annulus region surrounded by the riser and vessel wall. Water is pushed by the gas, creating a water circulation between the annulus and the riser and forms gas bubbles. Total mass transfer of gas and water is increased by the recirculation of gas bubbles improving the decontamination factor (DF). It also arrests any flame propagation from the containment with the help of water present in the filter. In stage 2, steam condensation occurs in the gas space which increases the water level during the initial venting phase. Larger droplets formed by the bubbles burst at the surface of water due to low gas velocity and thus does not go through the separation unit. The mass transfer rate is increased by the co-current scrubber within the core section and by large residence time through trapped bubbles in the recirculation zone. In stage 3, the moisture separation unit removes the water droplets and aerosol in the gas stream. Sodium thiosulfate is added to the filter vessel to reduce elemental iodine (I_2) and organic iodine (R-I) which are volatile. Sodium thiosulfate decomposes the dissolved elemental iodine and organic iodine into non-volatile iodide ions, increasing the pH of water leading to high reaction rate with CH_3I and I_2 . Sodium hydroxide is used to maintain high pH. This system belongs to two filter systems. In generation I, only sodium thiosulfate was used as chemical additive. Later filter generation II was conceptualized by connecting tanks filled with chemical additives to increase the iodine decontamination factor [7], where decontamination factor is the ratio of initial specific radioactivity to final specific radioactivity that is a result of a separation process. Its unique feature is faster reduction and efficient retention due to decomposition of all iodine species to I^- and prevention of the re-volatilization of the iodide ions respectively. A DF of 10 implies that 90% of the radioactive nuclides have been removed; it is one of the major aspects that form the basis of NPP safety design. A standard is set for each radioactive substance in a country by their respective regulatory body and only if the minimum DF is achieved can a NPP be installed. For example the DF of inorganic iodine should be greater than 200 for NPPs in Spain. This design offers high DF for both aerosols and iodine also preventing re-vaporization of both. The few disadvantages are risk of H_2 combustion due to high pressure vessel during outlet throttling of venturi nozzle and its complex structure. CCI containment venting vessel is shown in Fig. 2 and flow diagram of CCI containment venting system is in Fig. 3.

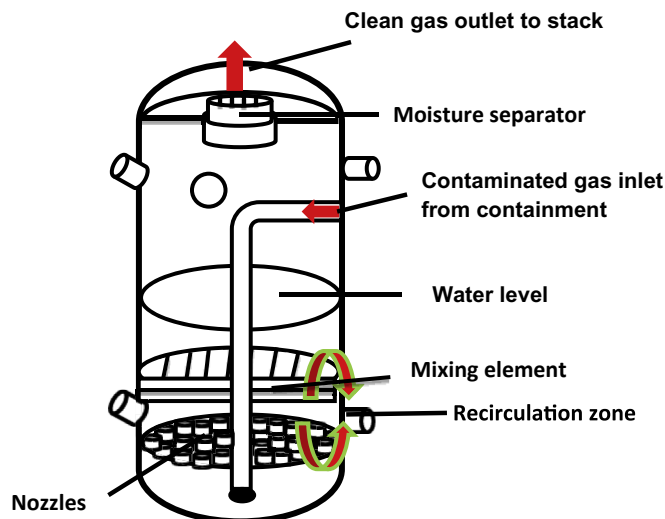

Fig. 2. CCI containment venting filter vessel [7].

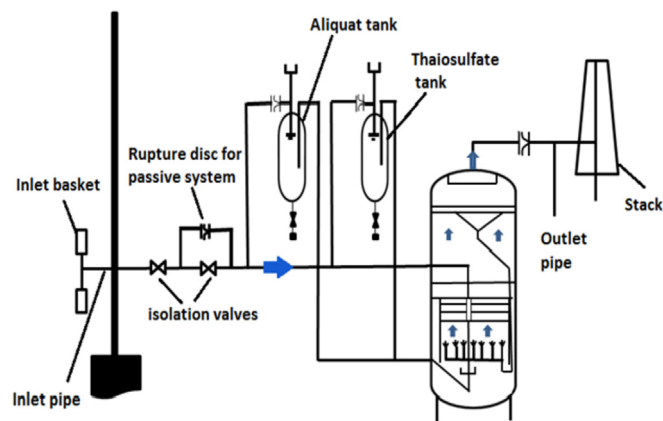

Fig. 3. Flow diagram of CCI Filtered containment venting system [7].

2.3. Sand bed filter

Sand bed filter was developed by the Electricity de France (EDF) and The Institute for Radiation Protection and Nuclear Safety (IRNS). Later a dry metallic pre filter was added to increase the decontamination factor (DF) of aerosol to 1000 and it was installed in the French, EDF power plant [4]. Sand bed filter designed as deep bed filtration operates under dry condition. It is a cylindrical tank made of 316L stainless steel. Due to its large dimension, the sand bed filter is kept outside the containment. After the operation, the

contents inside the filter generate high level of radiation. Metallic pre filter is able to keep 90% of radioactive material inside [8]. In the sand bed filter, the gas is uniformly dispersed throughout the filter by a constant mesh Kevlar lattice covering the sand bed. The gas then enters into the strainers made of stainless steel placed in the expanded clay and then goes to the rectangular collector in the filter area. A radioactive material measuring device is installed on the connecting pipe between the sand bed filter and the plant stack. The filter can withstand a pressure drop of 500 mbar. Re-vaporization and adsorption in the exterior of the sand bed filters and upstream piping balance the removal of the elemental iodine but it's unable to remove the organic iodides. DF of this filter is almost 100 for aerosol particles. From a safety perspective, whenever containment pressure reaches its design limit, the pre-heating and conditioning fan are firstly stopped and connected valves are closed. Then two isolation valves of the containment are manually opened and at this time the pressure and temperature of the containment and the release activity during the venting are continuously evaluated by the operators. On the other hand, venting system is manually stopped whenever the pressure is within the safe level. But, this filter faces some issues like risk of hydrogen combustion, safety issue of venting system on site accessibility and resistance to hazards of the FCVS at the time of accident i.e., earthquake [7]. Schematic view of sand bed filter is shown in Fig. 4.

2.4. Dry filter method

Dry filter method (DFM) was presented by the Karlsruhe Nuclear Research Centre KRANTZ-TKT [8]. DFM consists of modular filter stages. Two different types of filters are used for aerosol filtering and gaseous iodine retention. In the first stage, there is a deep bed metal fibre filter which removes the aerosols present in the venting gas using metal fibre fleece as the filter medium both consisting of stainless steel. It consists of multi staged design containing metal fibres of large diameter present in the initial stage, subsequently the diameter decreases, the diameters decrease from $65\ \mu\text{m}$ to $12\ \mu\text{m}$ and $12\ \mu\text{m}$ – $2\ \mu\text{m}$ in the two stages respectively. Maximum amount of the aerosols are retained in first stage, while the next filter stages increases overall filtering efficiency. Iodine is removed in the 2nd stage by an iodine filter fixed downstream of the aerosol filter, which is made of silver doped zeolite, nearly spherical in shape specifically designed for iodine absorption. The iodine is chemisorbed by silver bound to the zeolite. The system iodine removal efficiency is optimized and steam humidity is

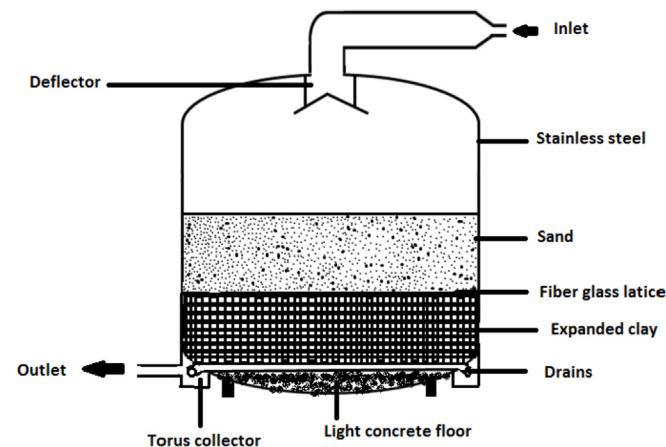

Fig. 4. Sketch of the sand bed filter of the FCVS system [7].

eliminated by the specific passive expansion of the venting gas. Fig. 5 shows a schematic view of interior configuration of containment of a DFM system. The iodine filter is placed outside of the containment, while the aerosol filter is located inside the containment. Aerosol filter is composed of various modules which are arranged in parallel configuration. Aerosol filter stages are shown in Fig. 6. German PWR installs 3 aerosol filter modules. Initially the gas enters the aerosol module, leaves the containment and enters the iodine filter. Finally, clean gas escapes to the environment after removing iodine. DFM offers, $DF > 10000$ for aerosols, $DF > 1000$ for elemental iodine and $DF > 40$ for organic iodine. Modification of zeolite filter should be done to get the desired retention efficiency of organic iodine [7,9]. Thus the DFM venting filter system consists of a combination of metal fibre and zeolite iodine filter modules and is designed in modules for easy adaption to meet plant requirements and safety regulations, which includes individual sizing of modules to fit into existing buildings. The system requires low maintenance cost, provides small pressure drop, high DF even for organic iodine (approximately 40), resists high temperature and radiation, exclusive passive mode of operation.

2.5. FILTRA MVSS

Westinghouse and Alstom presented a filtered vented containment system to mitigate the consequences of accidents occurring due to the over pressurization of the containments of nuclear power plants called FILTRA MVSS (Multi Venturi Scrubber System). It consists of various filtration steps: multi venturi scrubber, moisture separator, water pool and sintered metal fibre filter located in a tank. Aerosols are captured in the water pool and removal of iodine is done by adding the chemicals in water tank with the use of the highly efficient venturi scrubber. Sodium thiosulphate is added to remove the essential iodine and organic iodine [7]. The demister in the tank reduces more than 97% of the droplets and thus significantly contributes to the overall DF while the metal fibre filter is used for filtering particles less than $0.8\ \mu\text{m}$. Filtra MVSS is designed as fully passive mode for 24 h; in that time it requires neither water supply nor electrical power supply, only a rupture disc is needed to actuate the system [10]. Other advantages include withstanding high seismic loads, high decay heat capacity, versatile as it gives same DF at high temperatures independent of the vent flow rate, modular design. It is installed in all the Swedish nuclear power plants and Muhleberg BWR (Boiling Water Reactor) station in Switzerland because of its 99.9% removal efficiency of iodine and aerosols. Later it was further improved by replacing the gravel bed

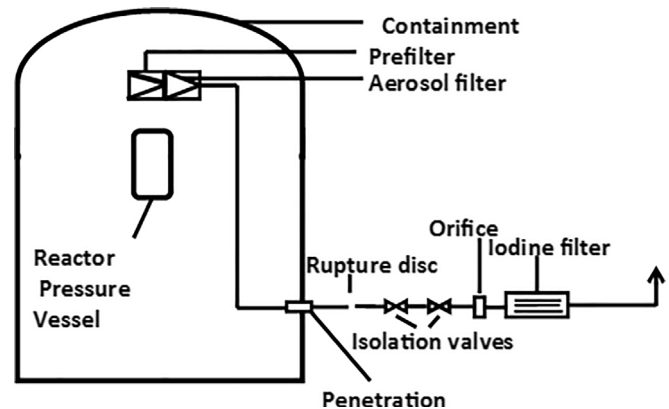

Fig. 5. Schematic view of the Dry Filter Method for containment filtered venting with aerosol filter inside containment [4,7].

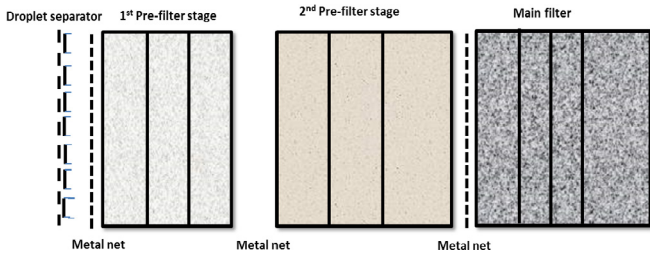

Fig. 6. Aerosol filter stages in DFM aerosol filters [7,9].

moisture separator with a standard demister. After the moisture separation step, a set of sintered metal fibre filter cartridges were added, leading to a tremendous increase in the radioactivity removal, DF > 10,000 was obtained for elemental iodine and DF ≈ 2 for organic iodine. Zeolite filter which enhances the removal efficiency of organic iodine can be added if required. A typical flow diagram of a FILTRA MVSS is shown in Fig. 7. Generation 2 FILTRA MVSS module is depicted in Fig. 8.

2.6. SVEN scrubber system

SVEN scrubber system, presented by Westinghouse is used to remove micro size radioactive particles using sintered metal fibre filters (MFFs), making them a suitable primary containment ventilation by submerging in liquid. The contaminated gas is passed through a metallic filter cartridge which is submerged in the liquid inside a pressure vessel and cooled [11]. More than 99% of aerosols (DF > 100) are removed by this filter without clogging or exhibiting large pressure drop. Scrubber liquid cools the decay heat from captured aerosols and after that the gas passes through a liquid volume, where scrubbing of liquid occurs. Elemental iodine is eliminated by the sodium thiosulphate present in the scrubber liquid. Sodium hydroxide is used to increase the pH level of liquid. Splash shield and demister are installed above the liquid to remove moisture. Metal fibre HEPA filters is placed in the upper part of the SVEN tank which removes the smaller aerosols of size 0.3 μm. Small amount of organic iodine is present in the exit gas from the SVEN tank. In the upper part of the tank, above the scrubber liquid, a splash shield and a demister are installed to eliminate moisture from the vent flow, downstream to which there are a set of fine MFFs at the tank top to remove smaller aerosols. To achieve the desired DF for organic iodine, gas is routed through the silver impregnated zeolite beads. Integrated SVEN filtered containment

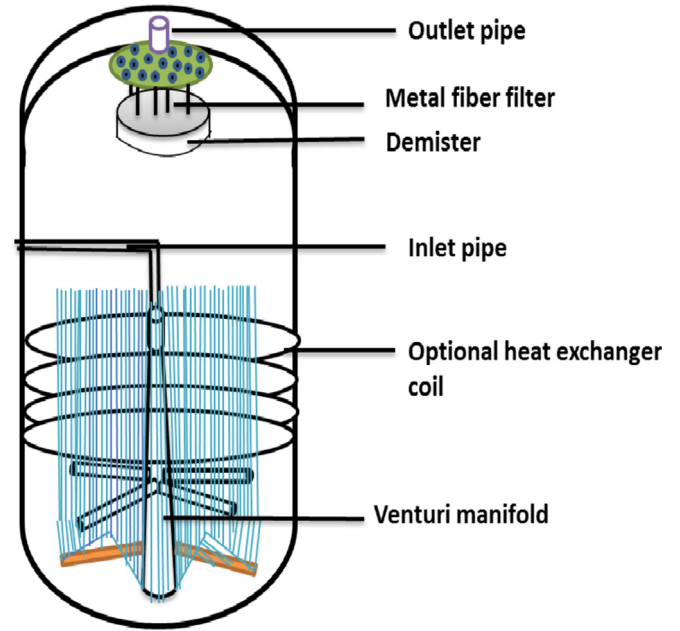

Fig. 8. Integrated FILTRA MVSS scrubber module [7,10].

venting system is shown in Fig. 9 and System Configuration of the SVEN scrubber is shown in Fig. 10. The advantages of this system are easy availability of filter media, possibility of scaling to fit into existing buildings, localized manufacturing of equipment when necessary and high DF values.

3. Current global scenario of implementation of filtered containment venting system

Subsequent to the Fukushima incident, the Nuclear Energy Agency (NEA) Committee on the Safety of Nuclear Installations (CSNI) initiated a number of significant actions; particularly stress tests were performed across the globe that led many countries to consider the implementation of FCVS. Despite serving the same purpose, each country has its own safety system, varying in design and structure, owing to the difference in regulatory guidelines; while some countries adopt stringent measures others take up bit more flexible ones with cost issues being one of the major reasons.

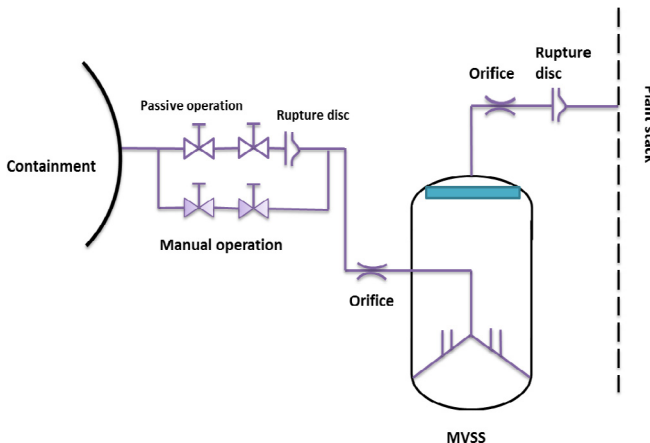

Fig. 7. System configuration of FILTRA MVSS venturi scrubber [7,10].

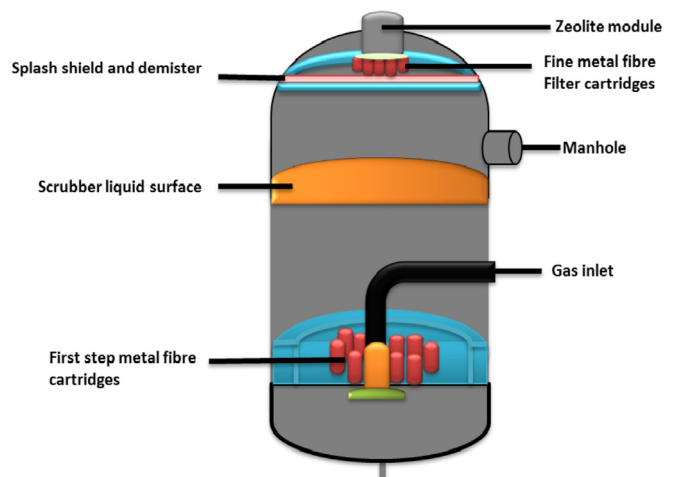

Fig. 9. Integrated SVEN filtered containment vent system [7,11].

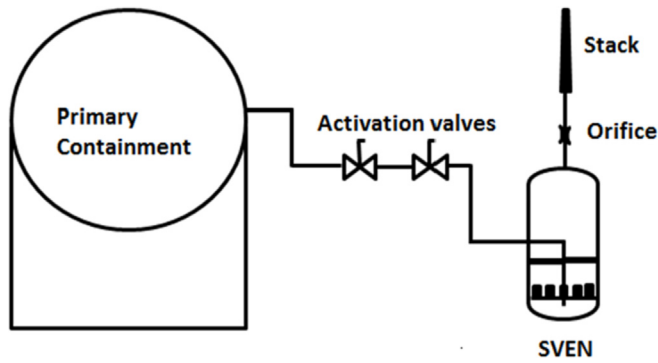

Fig. 10. System Configuration of the SVEN scrubber [11].

As of July 2018 nuclear power plants operate in 31 countries worldwide with a total of 453 nuclear reactors in operation, equalling 3975649 MWe of installed capacity, a brief description of the safety systems and legislations accepted in various countries is given below.

3.1. Sweden

All the present eight Swedish Nuclear power reactors in operation have a FCVS using Multi venturi scrubber filters of the FILTRA MVSS type in operation, providing about 35% of the total electricity [12]. They provide a minimum DF of 500 for BWR and 1500 for PWR. Since 2010 the Swedish Radiation Safety Authority (SSM) governs both the nuclear safety regulation and radiation protection. The 1980/1981 Energy Bill contains the fundamental policy guidelines for severe accident management and release mitigation. It dictated that at least 1000 of the core inventory of each radionuclide isotope excluding noble gases must be contained in the containment when venting during a severe accident. The new guidelines released in 1986 imposed a limit on the radioactive release to the environment as a maximum 0.1 percent of the reactor core content of Cesium-134 and Cesium-137. It was required by the licensees to construct strategies to protect the reactor containment function and permit the reactor to reach a stable condition where the core is cooled and covered by water. It was also essential that the containment function remains intact during the first 10–15 h after core damage.

3.2. Netherlands

Netherlands has one PWR in running condition and it has employed a wet scrubbing HSSPV type FCVS. It runs following the rules and regulations set by the 1963 Nuclear Energy Act [13].

3.3. France

About 75% of the electricity in France is obtained from nuclear power which is derived from 58 PWRs which employed FCVS by the early 1990s. This was a result of the plans and actions subsequent to the Three Miles occurrence which led to the France's Institute of Radiological Protection and Nuclear Safety (IRSN) to establish secondary measures to control accidental situations. The FCVS include a metallic filter inside the containment and a sand filter to completely retain aerosols [14]. Formed in 2006 the Nuclear Safety Authority (Autorite de Surete Nucleaire— ASN) is the regulatory authority in charge of nuclear safety and radiological protection. The basic design criteria of the FCVS included: manual initiation of the system, 5bar (abs) initiation pressure and more than 90%

(DF > 10) filter efficiency for aerosols and molecular iodine. Though there are Safety Guides which are a limited set of technical regulations for nuclear establishments there are no legally binding rules or guidelines for FCVS in France.

3.4. Germany

The national body which is concerned with licensing and governing nuclear facilities in Germany is the Federal Ministry of Environment (BMU). But the license for NPPs is provided by the states which are in charge for the execution of federal laws. 1 to 1.2 times containment design pressure is the accepted critical containment pressure for venting. The reactors use either the wet (Sliding pressure venturi scrubber) or the dry filter (Metal fibre filter) [15]. The wet filters primarily comprise of a venturi scrubber system with a metal fibre droplet filter unit similar to the FILTRA/MVSS and the dry filter system. The system should be initiated manually; the filter has DF > 1000 for aerosol and DF > 10 for molecular iodine and the initiation pressure should be same as CV test pressure, these are the basic design criteria laid down by the Reaktor Sicherheits Kommission (RSK), the German Reactor Safety Commission: "Guidelines 4.6.25 section 2.2.1 and 4.6.32 BI 9.3.3.2.5" in the KTA (Kerntechnischer Ausschuss) Safety Standards and Standard Series 1503, 3401, 3404, 3413 and 3601. Additionally all the isolation valve must be able to be opened closed or adjusted under all severe accident conditions.

3.5. Switzerland

Switzerland owns five reactors on four sites, three PWRs and two BWRs which supplies approximately 35% of the country's electricity. Three types of FCVS are currently in operation in the Swiss plants, the HSSPV, Filtra-MVSS and the SULZER-CCI-type. The basic requirement was that the aerosol and iodine retention factor should be greater than or equal to 1000 (99.9%) and 100 (99%) respectively [16]. The principal legislation governing nuclear energy is the 1959 Atomic Energy Act. From 2009 the Swiss Federal Nuclear Safety Inspectorate (ENSI) oversees the nuclear safety and security of the nuclear plants in the country. The following basic requirements were laid down by the "Hauptabteilung für die Sicherheit der Kernkraftwerke" (HSK) for containment integrity and mitigating measures: prevent uncontrolled radioactive release due to loss of integrity of the containment during severe accident (Prevention of long-term contamination by Cs); nominal relief capacity of 0.8% of thermal power; maximal relief capacity of 1% of thermal power; aerosol retention factor: ≥ 1000 (99.9%); iodine retention factor: ≥ 100 (99%).

3.6. Bulgaria

Bulgaria having two nuclear reactors on one site has implemented a HSSPV FCVS in them, this was in response to the new operation license issued by the Nuclear Regulatory Agency of Bulgaria in 2003 [17]. The two main bodies the Nuclear Regulatory Agency (NRA) associated with the safe uses of Nuclear Energy Act 2002 and the Kozloduy Nuclear Power Plant PLC are responsible for safety, radiation protection and management of nuclear wastes.

3.7. Slovenia

The one and only NPP in Slovenia, Krsko nuclear power plant is governed and licensed by the Slovenian Nuclear Safety Administration (SNSA), also by International Expert Missions coordinated by the IAEA, EU etc. and the radioactive waste is managed by the Agency for Radwaste Management (ARAO) [18]. Slovenia

completed installation of FCVS in November 2013 this was done as the response to Krško NPP safety upgrade programme. It was stated in the “Slovenian Report for the Second Extraordinary Meeting of the Parties of the Convention on Nuclear Safety, Report on actions, responses and developments influenced by the Fukushima Daiichi NPP accident” that the FCVS was credited for the filtering of over 99.9% of volatile fission products and particulates (excluding noble gases). But the current FCVS is approved only for passive use because flow meters and radiological monitoring devices have not yet been installed.

3.8. Finland

Two of the four NPPs in Finland have FCVS installed in 1990 as part of plant modification. The nuclear power operations and waste disposal are supervised by the Ministry of Trade and Industry, under the Nuclear Energy Act 1987 [19]. The capacity (thermal hydraulic design) of the FCVS is 12 kg/s of saturated steam at a containment pressure of 0.6 MPa and 6 kg/s at 0.3 MPa and the corresponding containment heat removal rates are 25 MW and 12.5 MW. In approximately 5 and 60 h after reactor shutdown these decay heat levels will be reached respectively. The design criterion of the filter is that the release would start at 8 h, continue for 16 h and terminate at 24 h. AC power is inferred to be restored at 24 h in the Olkiluoto 1 and 2 severe accident management units and the decay heat is assumed to be removed by the containment cooling system after that. The filter unit and the piping up to the filter are designed and insulated in such a manner that makeup of scrubber water is not required for a period of 24 h. Due to concerns of containment failure and occurrence of sub atmospheric pressure the other two units have not incorporated FCVS. The fifth plant under construction is not given permission to employ FCVS as the primary means of decay heat removal, according to Finnish regulations it should be resorted to at the last stage of a severe accident.

3.9. Canada

Four out of the five nuclear stations are in operation today and continue to supply more than 15% of electricity in the country. The regulations and requirements of FCVS are not distinctly commanded but the issues regarding venting to the atmosphere and containment integrity is managed by the CNSC. Prior to the Fukushima accident in 2011, Canada had FCVS installed in some of its plant and after its occurrence a CNSC Fukushima Task Force was launched which reviewed the NPPs in the country and recommended that more advanced FCVS are valuable and should be implemented as an additional defence. The filter designs under consideration are the AREVA and Westinghouse dry filter design using metal fibre filter and a zeolite “molecular sieve”. The design pressure, maximum design temperature and design load of aerosols of the seismically qualified, manually and remotely operated FCVS are 400 kPa, 200 °C and 300 kg respectively. They operate passively to relieve containment pressure and decontamination factor is more than 200 for aerosols and molecular Cesium and more than 100 for elemental iodine and approximately 5 for organic iodine. The purpose stated for the installation of FCVS in NPP in the country is “to prevent failure of containment integrity due to the increase of containment pressure beyond the failure pressure” around 220–230 kPa [20].

In response to the decision triggered by the Fukushima accident the installation process of FCVS is ongoing in countries like South Korea, Romania, Belgium and Japan and expected to be completed by 2018. Countries like Slovakia and Mexico have not felt the need for FCVS yet. USA and India are currently in the process of documentation and designing FCVS for its implementation. Taiwan

ordered the implementation of FCVS in 2012 after the NPPs were assessed and there is a future possibility for countries like Russia, Czech Republic, Hungary, Ukraine, United Kingdom and Spain to install FCVS as their requirement is being considered since the studies are reported in its favour.

Comparison of different FCVSs is shown in Table 2. According to the EU stress test reports (2012) [21] and survey of WGAMA task group, the status of the implementation of FCVS in different countries is presented in Table 3. Advantages and disadvantages of different FCVS system is mentioned in Table 4.

4. Recent advances and potential developments in FCVS

An appreciable amount of research is in progress in the area of FCVS: from pilot plant small scale experiments to large scale experiments for efficiency testing, computational fluid dynamics models for better understanding of the working of FCVS and optimization techniques for identifying the most efficient venting techniques. The efficiency of the FCVS is being attempted to be improved and has been proven to be feasible for attainment of the desired removal. Rising number of FCVS installations in NPPs, their inclusion in nuclear regulatory reports and guidelines as SAMM and the increase in countries considering its implementation, all underline the importance of FCVS as a Severe Accident Management Measure, accordingly leading to an intensified investigation.

Despite the large investment required to install FCVS many countries have already deployed it, while some are in the process and various other countries are considering its implementation. Extensive research and development is ongoing in several countries like India, Pakistan, Japan, China etc.

The Electric Power Research Institute (EPRI) investigated the strategies for mitigating radiological release in severe accident (2012) [22], key point of their analysis is one strategy is not sufficient to retain the radiation; the most effective method is the combination of the active debris cooling strategy and containment venting. Without debris active cooling, containment degradation and ultimate failure can occur and in the absence of a venting system the pressure formed due to steam created by the cooling of the debris using water can also lead to system collapse. Rather than that, spraying the drywell in an effective way increases the DF significantly. They also concentrated on the improvement of the venting system because opening and closing the vent at the most appropriate times is most important. Moreover, venting also manages the build-up of hydrogen and generation of other non-condensable gases at the time of core melting process. Basically, this report highlighted the need for Filtered Containment Venting Systems as a SAMM.

A submerged self-priming phenomenon has been introduced by Majid et al. (2012) for the removal of iodine in purpose of improvement of FCVS [23]. They carried out a series of experiments where the scrubbing liquid was prepared by adding 0.5% sodium hydroxide (NaOH) and 0.2% sodium thiosulphate ($\text{Na}_2\text{S}_2\text{O}_3$) in water and then introduced as film to the scrubber. They concluded with the result that a submerged self priming venturi scrubber gives enhanced iodine removal efficiency than non-submerged and it increases with iodine inlet concentration and gas flow rate. The decontamination factor was obtained around 1000. Thus it is a proof of concept that $\text{DF} \approx 1000$ can be achieved for iodine when incorporated in a FCVS.

Later, Zhou et al. (2016) [24] also conducted experiments on iodine removal and observed another interesting aspect of improvement, effects of some operating parameters i.e., liquid flow rates, gas flow rates and temperature on iodine removal. They found $\text{DF} = 100$ for iodine. The removal efficiency increases with increase in liquid flow rate and decrease in gas flow rate. When the

Table 2
Comparison of filtered containment venting systems.

| Supplier | CCI | AREVA | Westinghouse Dry | FILTRA MVSS | SVEN |
|------------------------|--------------------------------------------------------------------------------------------------------------------------------------------------------------------------------------------------------------------------------------------------------------------------------------------------------------------------------------------------------------------------------------------------------------------------------------------------------------------|-------------------------------------------------------------------------------------------------------------------------------------------------------------------------------------------------------------------------------------------------------------------------------------------------------------------------------------------------------------------------------------|--------------------------------------------------------------------------------------------------------------------------------------------------------------------------------------------------------------------------------------------------------------------------------------------------------------------------------------------------------------------------------------------------------------------------------------------------------------------------------------------------------------------------------------------------------------------------------------------------------------------------------------------------------------------------|-------------------------------------------------------------------------------------------------------------------------------------------------------------------------------------------------------------------------------------------------------------------------------------------------------------------------------------------------|---------------------------------------------------------------------------------------------------------------------------------------------------------------------------------------------------------------------------------------------------------------------------------------------------------------------------------|
| Design | CCI uses wet scrubber, Gas space above the water pool, Moisture Separation Unit. The system containing inlet basket inside the containment; inlet piping between the filter vessel and containment penetration, containment isolation valves; filter vessel and its internals; auxiliary systems; clean gas piping; instrumentation and control systems. | Areva uses high speed sliding pressure venturi scrubber technology combined with highly efficient fibre filter. All components are fixed in the pressure vessel and run under sliding pressure conditions. Venturi Scrubber Unit is containing a throttling orifice for a sliding pressure process, a venturi section, a metal fibre filter section and a droplet separator. | DFM uses a deep bed metal fibre filter to remove aerosols and a zeolite filter to discard iodine gases. It has a compact and modular design. DFM can be easily installed in existing plant structures for its modular design. Aerosol filter has been located inside the containment, ensuring that aerosol and iodine are safely contained during the venting process while still effectively decreasing containment pressure. The DFM does not require operator start up, needs no water or chemical make-up. It can be passively handled for months during an accident, has an efficient passive air-cooling system. Power supply is also not required. | FILTRA MVSS uses MVSS in a water pool to discard aerosols and various forms of iodine. Robust and seismically rugged design. FILTRA-MVSS is installed to the site as one compact unit with all required lifting arrangements. Unit is consisting of Venturi scrubber system, Sintered metal filter, Moisture separator, Support systems. | SVEN uses filter cartridges in a water pool to discard aerosols and various forms of iodine. It is a compact structured unit kept in a stainless steel tank. Small structured SVEN system to be installed in an existing plant. It is consist of a venturi scrubber system with a sintered metal fibre filter technique. |
| Re-volatilization | Demineralized water is required to fill in the filter vessel. Water refilling into the filter vessel is required. Chemical agents are put in the water in the filter vessel. All visual displays and devices are acted as passive systems and run without electric power. The piping systems contain rupture disks that will rupture on high pressure so that operator action is not required. Re-volatilization of iodine does not occur due to chemical binding. | Passive operation and operator-initiated start-up. Water is needed and recirculation of liquid pool is also done to store the activity inside the containment. The expected range of activity recirculation to the containment is 95–99%. Re-volatilization is negligible. Re-volatilization of iodine was <0.1% over a running period of even 24 h. | No test data Decay heat of DFM is reduced by cooling through natural convection of the filters. | No test data Decay heat load on the sintered metal fibre filters is diminished. | Re-volatilization due to acid environment Decay heat of encapsulated aerosols is reduced by convection. Control of captured fission produced decay heat of up to 500 kW per SVEN unit. |
| Decay heat capacity | – | – | – | – | – |
| Decontamination factor | DF > 10,000 for Aerosols DF > 2000 for Elemental iodine DF > 1000 for Organic iodine | DF > 10,000 for aerosols DF > 200–1000 for elemental iodine DF > 50 for organic iodine | DF > 10000 for aerosols DF > 1000 for elemental iodine DF > 40 for organic iodine | DF > 10000 for aerosols DF > 10000 for elemental iodine DF ≈ 2 for organic iodine | DF > 10,000 for aerosols DF > 10,000 for elemental iodine DF = 50 for organic iodine |
| Clogging | No filter clogging and hot spot risk | Clogging in metal fibre | Clogging in metal fibre. | clogging in metal fibre | None |
| Chemicals used | Sodium hydroxide (NaOH), Sodium thiosulphate (Na ₂ S ₂ O ₃) | Sodium hydroxide (NaOH), Sodium thiosulphate (Na ₂ S ₂ O ₃) | NA | Sodium thiosulphate (Na ₂ S ₂ O ₃), Sodium carbonate (Na ₂ CO ₃) | sodium thiosulphate (Na ₂ S ₂ O ₃), sodium hydroxide (NaOH) |
| Filtration process | Spurger assemblies, co-current scrubber, recirculation zone, droplet separator, chemical reduction and retention of iodine | Venturi scrubber and Metal fibre filter. | Metal fibre filter and molecular sieve. | Multi-venturi scrubber, a water pool, moisture separator, and finally an optional metal fibre filter | Sintered metal fibre filter, demister and very fine metal fibre filter. |
| Conclusions | Full filtration efficiency for low to high pressures. Unique technology of filtration and retention of iodine. No activity release during venting, multiple venting, post venting up to 1 year. | Very dependent on performance of metallic filter: clogging, hotspots, capacity. Higher excess storage capacity for iodine and aerosols. | Iodine retention system requires preheating Very high retention rates Modular installation of DFM allows existing buildings to be used and it minimize the overall filtered vent installation project cost by up to 50 per cent. | The Filtra-MVSS Venting System's water pool is useful for meeting higher requirements of aerosol loading. Filtra-MVSS Venting System is preferred for its high and consistent DF for aerosols and elemental iodine at a wide range of flow rates. | Efficient submerged metal fibre filter cartridges are responsible for the large DF for aerosols in the first filtration step. SVEN System has advantage for its robust structure: able to operate at a high flow rate, high aerosol loading and high heat loads, all in a small volume. |

Table 3
Status on the implementation of FCVS [7].

| Country | NPPs | No FCVS | HSSPV | Metal + sand bed | DFM | FILTRA MVSS | SULZER CCI | EFADS | Remarks |
|----------------|-----------------------------------------|---------|-------|------------------|-----|-------------|------------|-------|-------------------------------------------------------------------------------------------------------------------------------------------------------------------------------------------------------------------------|
| Belgium | 7 (PWR) | | ○ | | | | | | Installation of HSSPV in 5 units which starts between 2016-2018, assessment is going on remaining two unit which were just granted operation after 2015 |
| Bulgaria | 2 (VVER 1000) | | ☆ | | | | | | |
| Canada | 19 PHWR Single unit (1) Multi-unit (18) | | ☆ | | ○ | | | ☆ | Lepreau single unit is planned to install HSSPV, Dry filter method planned in four Darlington units, four EFADS shared among 18 reactor units, EFADS are designed for DBA |
| Czech republic | 4 (VVER 440) 2 (VVER 1000) | ● | | | | | | | No planned, under analysis in conjunction with SMM form Corium Cooling |
| Finland | 2 (BWR) | ● | ☆ | | | | | | FCVS is not reasonable in VVER 440 because the steel shell structure of containment is not safe at sub atmospheric pressures; EPR plant is under construction will be modified with Filtered venting containment system |
| France | 58 (PWR) | | | ☆ | | | | | Sand bed filter out side containment, Metal prefilter inside containment |
| Germany | 7 (PWR) 2 (BWR) | | ☆ | | ☆ | | | | Dry filter method in two pressurized water reactor units |
| Japan | 24 (PWR) 26 (BWR) | ▲ | ○ | | | | | | FCVS planned as "Specialized safety Facility" in PWRs, no design chosen HSSPV and other scrubber system outlined for BWRs, additional FCVS planned as "Specialized safety Facility" |
| Mexico | 2 (BWR) | ● | | | | | | | Hardened Containment venting system from dry well and wet wall (Mark II) will be implemented soon |
| Netherlands | 1 (PWR) | | ☆ | | | | | | |
| Romania | 2 (PHWR) | | ○ | | | | | | planned to install HSSPV |
| Slovakia | 4 (VVER 400) | ● | | | | | | | Under evaluation with other SMM |
| Russia | 6 (VVER 400) 11 (VVER 1000) | ● | | | | | | | After Fukushima, some Water-Water Energetic Reactors are under assessment |
| Slovenia | 1 (PWR) | | | | ☆ | | | | Dry filter method is installed in 2013 in Krsko Nuclear power plant and operated in passive mode with rupture disc. |
| South Korea | 19 (PWR) 4 (PHWR) | ▲ | ☆ | | | | | | Only Wolsong-I unit has been modified with HSSPV; Planning is going on on other units to install FCVS by 2018, implementation of a Korean system under consideration |
| Spain | 6 (PWR) 1 (BWR) | ▲ | | | | | | | Implementation of FCVS is planned by 2016 in PWRs Hardened venting is available, implementation of filter is expected by 2017 in BWR |
| Sweden | 3 (PWR) 7 (BWR) | | | | | ☆ | | | |
| Switzerland | 3 (PWR) 2 (BWR) | | ☆ | | | ☆ | ☆ | | HSSPV system at Gosgen; F-MVSS system at Muhleberg |
| USA | 69 (PWR) 35 (BWR) | ● | | | | | | | Documents on Hardened CVS for BWR Mark I and II mark has been assembled, installation starts by 2018 or earlier. |

● no FCVS ▲ planned but design not yet selected ☆ installed ○ planned

Table 4
Advantages and disadvantages of different FCVS system.

| CCI | AREVA | Westinghouse Dry | FILTRA MVSS | SVEN |
|-----------------------------------------------------------------------------------------------------------------------------------------------------------------------------------------------------------------------------------------------------------------------------------------------------------------------------------------------------------------------------------------------------------------------------------------------------------------------|---------------------------------------------------------------------------------------------------------------------------------------------------------------------------------------------------------------------------------------------------------------------------------------------------------------------------------------------------------------------------------------------------------------------------------------------------------------------------------------------------------------------------------------------------------------------------------------------------------------------------------------------------------------------------------------------------------|---------------------------------------------------------------------------------------------------------------------------------------------------------------------------------------------------------------------------------------------------------------------------------------------------------------------------------------------------------------------------------------------------------------------------------------------------------------------------------------------------------------------------------------------------------------------------------------------------------------------------------------------------------------------------------------------------------------------------------------------------------------------------|-------------------------------------------------------------------------------------------------------------------------------------------------------------------------------------------------------------------------------------------------------------------------------------------------------------------------------------------------------------------------------------------------------------------------------------------------------------------------------------------------------------------------------------------|------------------------------------------------------------------------------------------------------------------------------------------------------------------------------------------------------------------------------------------------------------------------------------------------------------------------------------------------------------------------------------------------------------------------------------------------------------------------------------------------------------------------------------------------------------------------------------------------------------------------------------------------------------------------------------------------------------------------------------------------------------------------------------------------------------------------------------------------------------------------------------------------|
| <p>Advantage</p> <ul style="list-style-type: none"> No filter clogging and hot spot risk. No activity release during venting, multiple venting, post venting up to 1 year. Re-volatilization of iodine does not occur. <p>Disadvantage</p> <ul style="list-style-type: none"> Water refilling into the filter vessel is required. Complex structure. risk of H₂ combustion | <p>Advantage</p> <ul style="list-style-type: none"> It can control decay heat of captured fission product up to >100 to >1000 KW. Retention of activity in short and long term is valid in vents operation. It considered the hydrogen safety Higher storage capacity for iodine and aerosols. Re-volatilization is negligible. <p>Disadvantage</p> <ul style="list-style-type: none"> Clogging problem can be observed with high aerosol load and high temperature. Re-suspension of deposited fission products due to multiple venting leads. Corrosion and high temp damage to metal fibres. | <p>Advantage</p> <ul style="list-style-type: none"> All long-lived aerosols are captured directly in the containment. Flexible modular design. Minimum hydrogen deflagration risks. Need of maintenance is very low. There is no requiring for chemistry control, heating systems or water make-up systems. Minimize the overall filtered vent installation project cost by up to 50 per cent. <p>Disadvantage</p> <ul style="list-style-type: none"> Zeolite can be poisoned by sulphur compounds, halogens, acid fumes and other fission products. Clogging in metal fibre. Re-vaporization and filter damage is expected. Critical mixed aerosol behaviour. | <p>Advantage</p> <ul style="list-style-type: none"> High and consistent DF independent on flow rate through the Venturi scrubber. Completely passive for at least 24 h. Can handle high decay heat load. Verified for high seismic loads. Easily adjustable to NPP unit. Independent Venturi system/ metal filter for Safety. <p>Disadvantage</p> <ul style="list-style-type: none"> Clogging in metal fibre. FILTRA MVSS is expensive. | <p>Advantage</p> <ul style="list-style-type: none"> High filter efficiency. Highly efficient first filtration step for submerged metal fibre filter cartridges and minimum decay heat on the 2nd set of HEPA rated metal fibre filters, causes optimal performance. Decontamination factor is stable at all venting conditions. Can handle high aerosol and fission decay heat loads due to submerge of scrubber in water. Emergency AC or DC power and any auxiliary systems are not required for safety. Routine maintenance of the SVEN system is minimum because it's simple and rugged design. <p>Disadvantage</p> <ul style="list-style-type: none"> Re-volatilization due to acid environment. Low DF for the elemental iodine in SVEN confirming by preliminary bubble test results. |

gas velocity is a constant, increase in temperature enhances the absorption process. They also concluded that the inlet iodine concentration was not a determining factor for removal efficiency. Consequently the flow rates of liquid and gas should be cautiously

optimized and selected to enhance the removal efficiency. Hydraulic behaviour is another important aspect for the improvement which was investigated by Horiguchi et al. (2014) [25]. They conducted research on the venturi scrubber to study the

operational characteristics of filtered venting by understanding the mechanism of self-priming and hydraulic behaviour in the venturi scrubber which is affected by gas-liquid flow rates and shape of the scrubber. The gas releases through a submerged venturi scrubber and gas-liquid contact with spray flow (flow in an oblique angle) which is formed by liquid suctioned through a hole due to the difference in pressure between inner and outer parts of the venturi throat both simultaneously enhance scrubbing of contaminated gas. This is known as self-priming venturi scrubber. They did a theoretical one dimensional analysis based on the experimental observations and concluded that with the self-priming nature, dispersion increases and the hydraulic behaviour changes from smooth to complicated depending upon the gas flow rates. At higher gas velocities the scrubber lapses to sonic suspension mode as the velocity in throat reaches the sonic velocity and leads to an increase in pressure in the venturi scrubber. Ergo the filter efficiency can be surpassed by operating the venturi scrubber in the self priming mode and under optimal gas flow rates.

Another aspect of improvement of FCVS has been done by The Central Research Institute of Electric Power Industry (CRIEPI) (2014) full-height FCVS test facility in Japan. They evaluated FCVS performance in several cases and determined the DF of organic iodine, elemental iodine and aerosols. A mixture of 0.2 wt% sodium thiosulfate ($\text{Na}_2\text{S}_2\text{O}_3$) and 0.5 wt% NaOH was employed as the iodine absorber. The experimental results proved low dependence of iodine DF on flow dynamics and a significant dependence on solution property [26]. Hence this research gave the idea of improvement of FCVS by choosing the appropriate absorbing solution for the removal of radioactive material.

The four year (2013–2016) PASSAM (Passive and Active Systems on Severe Accident source term Mitigation) Project in Europe was initiated under the foundation of the 7th framework of the European Commission coordinated by the IRSN (Institut de radioprotection et de sûreté nucléaire) constituting 9 partners from 6 countries [27]. PASSAM report put forward many important aspects about the FCVS. They mainly focused on the enhancement of safety and introduction of a cost effectiveness system. In addition, they also studied the retention phenomena for each type of mitigation system and established some important models and correlations which could be implemented by computer code ASTEC at the time of SA. Their experimental studies were performed both for existing systems i.e., water scrubbing (PSI, CIEMAT, RSE, AREVA, IRSN) and sand bed filters plus metallic pre-filters (IRSN) and for innovative ones i.e., acoustic agglomerates (CSIC), high pressure sprays (RSE), electrostatic precipitators (VTT), advanced zeolites (University Lorraine) and combined wet-dry filtration systems (AREVA). The analysis of the data obtained and the derivation of correlations facilitated the improvement of models currently existing and identification of the key variables that should be taken into account for upgrading the models and future developments.

A scaling method was proposed by Song et al. (2017) to design a reduced scale experimental facility to test a novel FCVS [28]. A full height facility at predefined pressure and temperature conditions was selected such that the physical and the geometrical similarities were preserved. Scaling of the components was done utilizing the prototype of the components in the FCVS comprising of a venturi scrubber, a cyclone, a metal fibre filter, and a molecular sieve. This approach claimed to minimize scaling distortions and stated that a properly scaled test facility permits testing in a wide range of initial and boundary conditions so that it can anticipate the complete performance of the FCVS prototype. Therefore better design models of FCVS can be achieved and more realistic and efficient FCVS can be constructed.

Employing an integrated severe accident code THALES2/KICHE Zheng et al. (2017) [29] developed a Bayesian optimization

approach to venting operations in a simulation based perspective. Venting operations are affected by a number of parameters and it's difficult to manually analyse them simultaneously. Simulations utilizing integrated severe accident codes are necessary to obtain the optimal setting of these influential factors with an objective of minimization of fission-product release. Their aim was to find the value of x^* , the specific input that would minimize the fission product release i.e. the objective function $f(x)$, the input vector defined for this was $x = [x_1, x_2, x_3, x_4]^T$, where x_1 is the pressure (forced open), x_2 is the pressure (conditional open), x_3 is containment fission products mass criterion and x_4 is the pH value criterion. A variety of venting strategies was identified by them as a result of their work. Two important types were found: first, to depressurize the containment through the wet well at the maximum acceptable pressure; second, to depressurize prematurely when the contaminant level is low and the pH level in the wet well realizes a certain source term assumption. The first plan was concluded to be superior to the second but it involved higher possibility of overpressure containment failure. Thus the code helps in determining the most efficient venting strategy.

A computational model replicating the three phase flow occurring in a venturi scrubber was developed by Moharana et al. (2017) and its applicability to the self-priming mode of operation was tested [30]. The model incorporated the effect of droplet collision and accounted for the droplet volume in regions of high liquid concentration. From the results they found that higher liquid flow rates and larger nozzle diameters increases the jet penetration and collection efficiency. A novel analytical tool termed performance parameter which is the ratio of the jet penetration and the outlet diameter obtained at the throat was coined by them to associate the hydrodynamic behaviour at the throat to the overall collection efficiency of the scrubber, they were found to be directly proportional. This can thus be beneficial in obtaining better designs for venturi scrubbers to achieve higher DF values.

Recently, Bal et al. (2018) [31] tried to improve the decontamination factor of iodine in filtered containment venting system by considering the potassium iodide solution as scrubbing liquid and also investigated the effect of operating parameters on removal efficiency.

5. Current challenges and possible improvements of filtered containment venting system

After investigation of all researches and observing the current status of implementation of FCVS systems in NPP, one can say FCVS still faces certain issues which should be rectified. Minimum DF of 1000 and 100 for aerosols and iodine respectively is not currently achieved by all FCVS installed in NPPs; many FCVS can't remove or have a low DF for organic iodine which should be improved. Availability of FCVS throughout the station black out period is another obstacle that should be addressed since majority of the FCVS can operate continuously for approximately 24 h which should be extended in case of unforeseen natural calamities. Attaining an optimized control of containment pressure to protect its integrity is a challenge that can be resolved easily by applying proper optimization techniques to the design and operation of the FCVS. By performing passive heat removal from the filter due to decay, the risk of occurrences of accidents can be substantially reduced. Secure maximum relief capacity for steam production; if all FCVS could operate independently for at least 100 h maximum safety could be assured. If these challenges can be addressed and realized, the efficiency of FCVS will drastically outdo its current state.

Despite all negative factors there are some scopes for improvement of FCVS in which researchers can focus in the future.

Performance can be improved by avoiding the sharing of FCVS with more than one unit. Sharing reduces the dedication of the FCVS to its sole purpose. Another possibility is that pre filtration can be enabled in the containment which can lessen the load on the external filter. On the other hand, by developing more robust instruments and systems the versatility of the FCVS can be guaranteed and chances of failure and faults can be drastically decreased. Controlling over-pressurization in the initial stage of the accidents minimizes the probability of hazards. The scrubbing liquid can be recycled back to the containment ergo making maximum use of it and reducing material costs. Reducing H₂ combustion risk is another major challenge of filtered containment venting system. Designing and operating the system in such a way to ensure flammability of the passing gas does not cross its limit and modelling the system to resist dynamic loadings produced from the hydrogen combustion. It can be controlled by employing special features like combustion quenching and capture inside the system by utilizing different methods such as hydraulic pools or packed filters or specially designed flame arrestors. Besides, performing periodic reviews on the system and upgrading when necessary to incorporate latest technology the system faults can be identified if any and corrected consequently ensuring uninterrupted and efficient working. The improvements include both tangible and intangible approaches. The tangible methods like design of the system, ensuring total dedication of the system to one unit, enabling pre filtering are all controllable while the intangible ones that involve direct human involvement like periodic checking, faulty instruments, having inevitable chances of error aren't controllable. Hence the focus should be to achieve the tangible techniques.

6. Conclusions

As demonstrated in this paper, filtered containment venting system is required in order to mitigate the consequences of severe accidents that occur in nuclear power plants. Existing technologies for filtered containment venting system have been described which include high speed sliding pressure venturi (HSSPV) scrubber, CCI filtered containment venting system, sand bed filter, dry filter method, FILTRA MVSS and SVEN scrubber system. In case of containment release, filters in FCVS reduce the uncontrolled release of fission products. Comparative study of different FCVS technologies has been reported in this paper and it's demonstrated that all FCVSs incorporate state of the art filtration technique, modified the use of chemicals in scrubbing liquid and improve the decay heat capacity and serve as a hydrogen mitigation system to achieve the desired decontamination factor of radioactive material at the time of severe accident. Several countries have initiated the process of modifying their nuclear power plants to FCVS. This paper summarizes the current scenario of installation of the filtered containment venting systems (FCVS) in different countries like Sweden, Netherlands, France, Germany etc. and the legislations regarding the nuclear power and safety. From the recent research activities and discussions being held with different countries in conferences on nuclear technologies and safety, the significance of incorporation of FCVS in a nuclear reactor is quite evident. Many countries that do not employ FCVS currently like USA, United Kingdom, Pakistan, China etc. are foreseeing its installation while the construction process is ongoing in some. As is evident from the present review article, researches on FCVS is not exhausted, there is still room for advancements that can be implemented in the future power plants. Despite the realization of modern filtration technologies FCVS face many challenges like low DF for organic iodine, availability throughout the station black out period, attaining optimized control of containment pressure to protect its integrity,

performing passive heat removal from the filter due to decay and has scope for improvement. Therefore, researcher should pay attention on some specific factors like avoiding the sharing of FCVS with more than one unit, enabling pre filtration in the containment, developing more robust instruments and systems, controlling over-pressurization in the initial stage of the accidents, recycling the scrubbing liquid back to the containment and reducing H₂ combustion risk. To accomplish its full potential the improvements stated above should be fulfilled, which can then promise the mitigation of nuclear accidents and safer handling of nuclear power.

Acknowledgement

Authors are thankful to IIT Kharagpur for funding this work.

References

- [1] National Research Council, Lessons Learned from the Fukushima Nuclear Accident for Improving Safety of U.S. Nuclear Plants, The National Academies Press, Washington, DC, 2014, p. 394.
- [2] N.P. Gulhane, A.D. Landge, D.S. Shukla, S.S. Kale, Experimental study of iodine removal efficiency in self-priming venturi scrubber, *Ann. Nucl. Energy* 78 (2015) 152–159.
- [3] Nuclear Energy Agency (NEA) and Organization for Economic Cooperation and Development (OECD), Five Years after the Fukushima Daiichi Accident: Nuclear Safety Improvements and Lessons Learnt, 2016.
- [4] C. Hillrichs, D. Vignon, P. Felten, Review of European filtered containment venting systems, *Nuc Advisor* 168/172 boulevard de Verdun, 92408 Courbevoie Cedex – France, 2012.
- [5] J. Beck, M. Welker, Filtered containment venting: reasons, technology. impact on environment, *J. Energy Power Eng.* 10 (2016) 765–769.
- [6] Filtered Containment Venting System Proven Technology – Passive Operation, Areva Inc., 2011.
- [7] Status Report on Filtered Containment Venting Committee on the Safety of Nuclear Installations Nuclear Safety, NEA/CSNI/R, 2014.
- [8] B. Eckardt, N. Losch, Filtered containment venting system, designs development-features qualification applications, in: *NRC Meeting on Containment Venting Systems* Rockville, 2012.
- [9] L.L.C. Westinghouse Electric Company, Filtered Containment Venting: the Dry Filter Method, April 2015. NS-IMS-0054.
- [10] Nuclear Services/Engineering Services FILTRA-MVSS, April 2012. NS-ES-0207.
- [11] Westinghouse Electric Company LLC, Safety Venting (SVEN) System, September 2014. NS-ES-0265.
- [12] Filtered Containment Venting in Sweden Historical Background, Regulatory Requirements and Design. https://www.iaea.org/NuclearPower/Downloadable/Meetings/2015/2015-08-31-09-03-NPTDS/1_02_Sweden_FCVS_in_Sweden_IAEA_2015_Wiktor_Frid.pdf (accessed 23rd July 2018).
- [13] Independent Nuclear Regulatory Body Created, Government of Netherlands, 2014. <https://www.government.nl/latest/news/2014/01/24/independent-nuclear-regulatory-body-created>. (Accessed 23 July 2018).
- [14] E. Rainmond, Continued Efforts to Improve the Robustness of the French Gen I Pwrs with Respect to the Risks of Severe Accidents: Safety Assessment and Research Activities, Euro safe, 2011. https://www.eurosafe-forum.org/sites/default/files/Eurosafe2011/1_1_%20E%20Raimond_French_PWRS%20slides.pdf. (Accessed 23 July 2018).
- [15] M. Loffler, M. Braun, Evaluation of filtered containment venting systems with MELCOR for extended operating conditions in German PWR, in: *EMUG-meeting*, Bratislava, Slovakia, April 15th–16th, 2014.
- [16] J. Hammer, ENSI, A. Ritter, Filtered Containment Venting Systems at Swiss NPPs and KKL in Particular, Swiss Federal Nuclear Safety Inspectorate ENSI, 2014, in: <http://www.iso-network.net/publications/pub-proceedings/symposia/north-american-tc-symposia/fort-lauderdale-usa-january-2014/slides-8/2571-ritter2014-ppt/file.html>. (Accessed 23 July 2018).
- [17] Results from modernization of the containment localization systems of the Kozloduy NPP units 3 and 4, Sabin Sabinov – KNPP http://www.iaea.org/inis/collection/NCLCollectionStore/_Public/37/038/37038482.pdf (Accessed 23rd July 2018).
- [18] Slovenia, European Nuclear Safety Regulators Group. <http://www.ensreg.eu/country-profile/Slovenia> (accessed 23rd July 2018).
- [19] Finland, European Nuclear Safety Regulators Group, <http://www.ensreg.eu/country-profile/Finland> (accessed 23rd July 2018).
- [20] S.G. Garbrah, Regulatory Oversight of Filtered Venting and Containment Integrity at Canadian Nuclear Power Plants, Canadian Nuclear Safety Commission, 2015.
- [21] EU Stress Tests Report, European Commission, press release, Brussels, 4 October 2012.
- [22] Investigation of Strategies for Mitigating Radiological Releases in Severe Accidents, BWR Mark I and Mark II Studies, Technical Report, 2012.

- [23] M. Ali, Y. Changqi, S. Zhongning, G. Haifeng, W. Junlong, K. Mehboob, Iodine removal efficiency in non-submerged and submerged self-priming venturi scrubber, *Nucl. Eng. Technol.* 45 (2012) 203–210.
- [24] Y. Zhou, Z. Sun, H. Gu, Z. Miao, Performance of iodide vapour absorption in the venturi scrubber working in self-priming mode, *Ann. Nucl. Energy* 87 (2016) 426–434.
- [25] N. Horiguchi, H. Yoshida, S. Uesawa, A. Kaneko, Y. Abe, Relationship between self-priming and hydraulic behaviour in Venturi Scrubber, *Mech. Eng. J. Bull. JSME* 1 (2014) 4.
- [26] T. Kanai, M. Furuya, T. Arai, N. Tanaka, Y. Nishi, K. Shirakawa, S. Nishimura, M. Satake, Effect of Two-phase Flow Structure in Decontamination Factor of Filtered Containment Venting System, ICONE22, July 7–11, Prague, Czech Republic, 2014.
- [27] T. Albiol, L. Herranz, E. Riera, C. Dalibart, T. Lind, A. Del Corno, T. Kärkelä, N. Losch, B. Azambre, C. Mun, L. Cantrel, PASSAM Final Synthesis Report, PASSAM–DKS-T28 [D5.5] IRSN/PSN-RES/SEREX/2017-00165, 2017.
- [28] J.H. Song, H.J. Jo, K.S. Ha, J. Jung, S.M. An, H.Y. Kim, S.T. Revankar, A scaling analysis for a filtered containment venting system, *Nucl. Tech.* 195 (1) (2017) 29–43.
- [29] X. Zheng, J. Ishikawa, T. Sugiyama, Y. Maruyama, Bayesian optimization analysis of containment-venting operation in a boiling water reactor severe accident, *Nucl. Eng. Tech.* 49 (2017) 434–441.
- [30] A. Moharana, P. Goel, A.K. Nayak, Performance estimation of a venturi scrubber and its application to self priming operation in decontaminating aerosol particulates, *Nucl. Eng. Des.* 320 (2017) 165–182.
- [31] M. Bal, T.T. Reddy, B.C. Meikap, Performance evaluation of venturi scrubber for the removal of iodine in filtered containment venting system, *Chem. Eng. Res. Des.* 138 (2018) 158–167.