

A Novel Method to Design an Optimum Dispersion Map for a Wavelength Division Multiplexing Ring Network

Jong-Hyung Lee*

Department of Electronic Engineering, Donggeui University, Busan 47340, Korea

(Received February 26, 2019 : revised May 8, 2019 : accepted May 9, 2019)

We propose a novel method to design a dispersion map for a WDM (Wavelength Division Multiplexing) ring network with the capability of wavelength reconfiguration. The method is simple, but gives us an optimum set of DCMs (Dispersion Compensation Modules) which satisfies a given value of the tolerable residual dispersion. The proposed method does not depend on compensation method, fiber type, or modulation format. We also demonstrate numerically how it works with an example 10-node ring network.

Keywords : Dispersion map, Ring network, WDM

OCIS codes : (060.1155) All-optical networks; (060.4262) Networks, ring; (060.2330) Fiber optics communications

I. INTRODUCTION

Nowadays, many metropolitan core networks utilize existing WDM systems engineered for a long-haul network [1]. While point-to-point topology is predominantly used for long-haul WDM networks, ring topology is particularly used for metropolitan WDM networks because SONET/SDH are usually configured in a ring architecture [2]. Regardless of the network's topology, dispersion is one of the major impairments in a WDM transmission system, especially for bit rates of 10 Gb/s or higher. The most popular way of compensating for dispersion is to use dispersion-compensation fibers (DCFs). Commercially available DCF modules are most suitable for compensating chromatic dispersion across the C band (1525~1565 nm in wavelength) of a conventional single-mode fiber (ITU G.652), which is deployed widely for terrestrial networks [3]. However, a DCF module requires additional cost and higher amplification of signals to compensate for its insertion loss. Therefore, it is necessary to design a network with a minimal set of DCFs.

In a long-haul WDM system it is relatively easy to design a dispersion map, because the signal's transmission distance (i.e. the fiber length) is fixed. Therefore, DCFs can be placed periodically. An "optimum" dispersion map

in a long haul WDM system usually refers to optimization of the signal's power level, to mitigate fiber nonlinearities while keeping OSNR as large as possible [4-9]. However, in a metro ring network with the capability of wavelength reconfiguration, designing the dispersion map can be a more challenging task, because the distances (fiber lengths) between each node are inevitably irregular, which makes it impossible to place DCFs in a regular pattern. Furthermore, if there are N nodes in the network, then we need to consider $N \times (N-1)$ dispersion maps, because a wavelength path starting at any given node can terminate at any of the remaining $(N-1)$ nodes. Residual dispersions of all $N \times (N-1)$ cases should be below a certain value to meet the performance criterion, even though the criterion may not be as strict as in a long-haul WDM system.

Figure 1 shows the typical structure of a node with the capability of wavelength reconfiguration. Any wavelength can be dropped or added at the node, while the remaining optical channels will pass through the node. One (or two) optical amplifiers should be placed before (and after) the node to compensate power loss due to not only fibers but also optical devices such as a multiplexer/demultiplexer, optical cross-connect, etc. in the node. A DCF is usually placed with an optical amplifier [2].

*Corresponding author: jonghlee@deu.ac.kr, ORCID 0000-0001-6764-9603

Color versions of one or more of the figures in this paper are available online.



This is an Open Access article distributed under the terms of the Creative Commons Attribution Non-Commercial License (<http://creativecommons.org/licenses/by-nc/4.0/>) which permits unrestricted non-commercial use, distribution, and reproduction in any medium, provided the original work is properly cited.

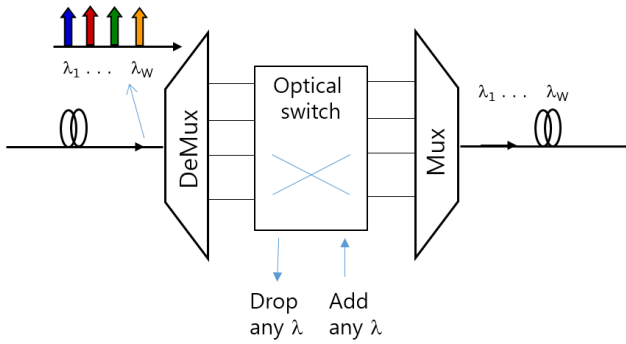

FIG. 1. Typical node structure capable of wavelength reconfiguration.

Although many reports have been published on dispersion compensation in a long-haul WDM system [4-9], no work has been reported on an algorithm to design a dispersion map for a ring network, to our knowledge. In this paper, we present a novel algorithm to find the minimum set of DCFs in a ring network that will keep the residual dispersion at every node below a predetermined value.

II. METHODOLOGY FOR DESIGNING AN OPTIMUM DISPERSION MAP FOR A WDM RING NETWORK

Most metro core networks today are built on two unidirectional (clockwise and counterclockwise) fiber rings. However, for simplicity, we will consider counterclockwise traffic only, as shown in Fig. 2. Basically there are two configurations to compensate fiber dispersion, namely, postcompensation (Fig. 2(a)) and precompensation (Fig. 2(b)). If we ignore the fiber's nonlinearities, there will be no difference in signal quality between these two configurations, because chromatic dispersion in fiber is a linear phenomenon [1].

First, let us consider optical signals traveling one link only from each node in a ring network with N nodes. With the postcompensation configuration shown in Fig. 3(a), the accumulated dispersions should meet the following conditions:

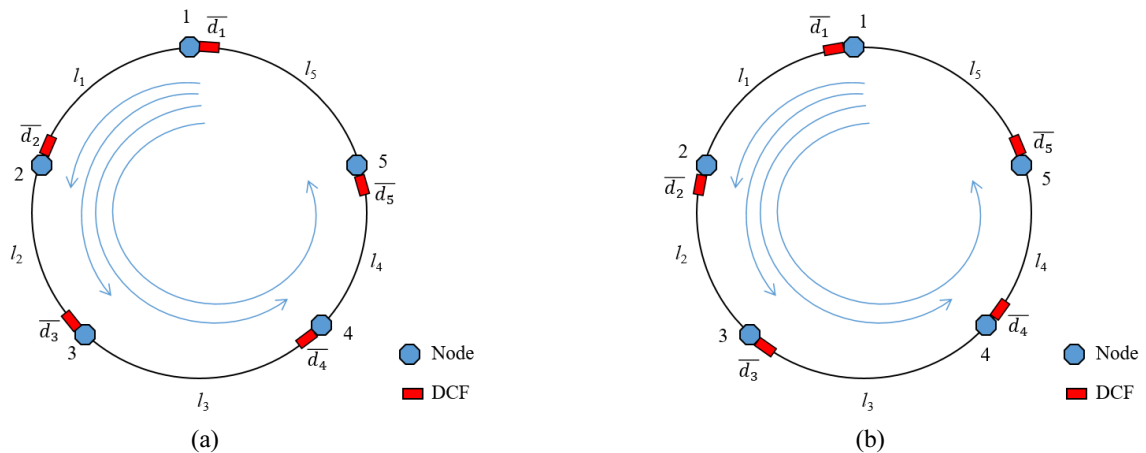

FIG. 2. 5-node ring network with counterclockwise traffic: (a) postcompensation configuration, (b) precompensation configuration.

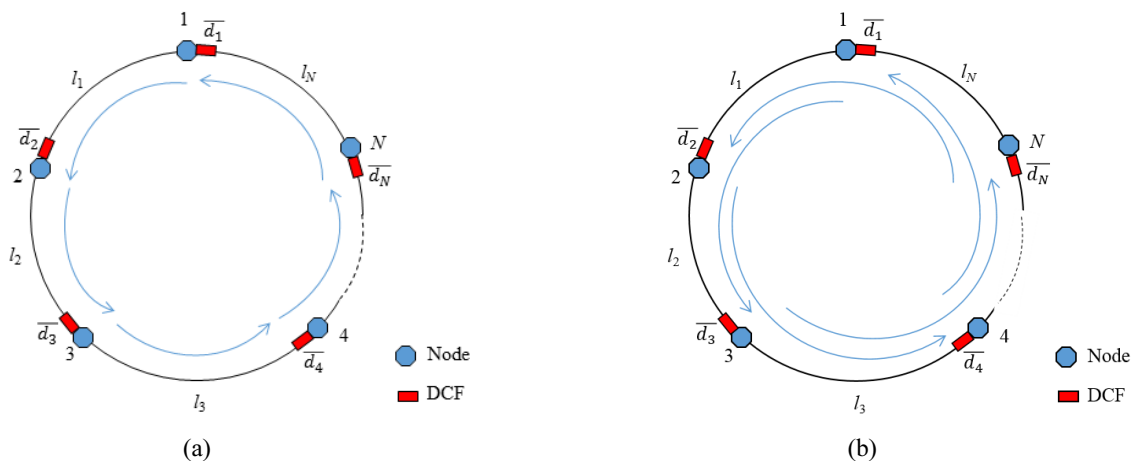

FIG. 3. Signal travel starting from each node: (a) one-link travel, (b) two-link travel.

$$\begin{aligned}
D_1 l_1 + \bar{d}_2 &\leq d_{tol} \\
D_2 l_2 + \bar{d}_3 &\leq d_{tol} \\
&\vdots \\
D_N l_N + \bar{d}_1 &\leq d_{tol}
\end{aligned} \tag{1}$$

where D_i [ps/(nm·km)] and l_i [km] are the dispersion parameter and the length of the i^{th} link fiber respectively. \bar{d}_i [ps/nm] (<0) is the dispersion of DCF at the i^{th} node and d_{tol} [ps/nm] is the allowed residual dispersion in the network.

By summing Eq. (1), we obtain the condition for DCFs, $\bar{d}_{DCF_s} \leq -d_{loop} + Nd_{tol}$, where $\bar{d}_{DCF_s} = \sum_{i=1}^N \bar{d}_i$ is the total dispersion of DCFs in the network, and $d_{loop} = \sum_{i=1}^N D_i l_i$ is the total dispersion in the network due to link fibers.

Now, if we consider optical signals traveling two links only from each node (Fig. 3(b)), then the accumulated dispersions should meet the following conditions.

$$\begin{aligned}
D_1 l_1 + D_2 l_2 + \bar{d}_2 + \bar{d}_3 &\leq d_{tol} \\
D_2 l_2 + D_3 l_3 + \bar{d}_3 + \bar{d}_4 &\leq d_{tol} \\
&\vdots \\
D_N l_N + D_1 l_1 + \bar{d}_1 + \bar{d}_2 &\leq d_{tol}
\end{aligned} \tag{2}$$

Again, by summing Eq. (2) we get $\bar{d}_{DCF_s} \leq -d_{loop} + \frac{N}{2}d_{tol}$, which is now a stricter condition than the previous one. Similarly, if we consider optical signals traveling the farthest, that is $(N-1)$ links from each node, we get

$$\bar{d}_{DCF_s} \leq -d_{loop} + \frac{N}{N-1}d_{tol} \tag{3}$$

which is the strictest condition for the total dispersion of DCFs, \bar{d}_{DCF_s} . Therefore the condition in Eq. (3) will guarantee that all of the accumulated dispersions of $N \times (N-1)$ cases are below d_{tol} . In a similar way, we can obtain the same result for the precompensation configuration.

Now, from Eq. (3) the total dispersion of the minimum set of DCFs is

$$\bar{d}_{DCF_s, \max} = -d_{loop} + \frac{N}{N-1}d_{tol} \tag{4}$$

If d_{tol} is close to zero, $\bar{d}_{DCF_s, \max}$ should be equal to $(-d_{loop})$, which can be achieved by letting the dispersion of each DCF compensate the previous link exactly. Fortunately, most metropolitan networks do not use a very high bit rate, say 40 Gb/s or above. In that case we can have a more relaxed condition for \bar{d}_{DCF_s} . For example, it is known that the maximum allowed dispersions for a bit rate of 10 Gb/s in NRZ format are 1200 ps/nm and 1900 ps/nm for a power penalty of 1 dB and 2 dB respectively [2].

2.1. Ideal Compensation with a Given Dispersion Tolerance

Let us consider a signal traveling farthest, starting from each node. The accumulated dispersions should meet the following conditions:

$$\begin{aligned}
d_{loop} - D_N l_N + \bar{d}_{DCF_s} - \bar{d}_1 &\leq d_{tol} \\
d_{loop} - D_1 l_1 + \bar{d}_{DCF_s} - \bar{d}_2 &\leq d_{tol} \\
&\vdots \\
d_{loop} - D_{N-1} l_{N-1} + \bar{d}_{DCF_s} - \bar{d}_N &\leq d_{tol}
\end{aligned} \tag{5}$$

Then the minimum requirement for each DCF can be obtained when \bar{d}_{DCF_s} is given by Eq. (4). That is,

$$\begin{aligned}
(-\bar{d}_1)_{\min} &= \frac{-1}{N-1}d_{tol} + D_N l_N \\
(-\bar{d}_2)_{\min} &= \frac{-1}{N-1}d_{tol} + D_1 l_1 \\
&\vdots \\
(-\bar{d}_N)_{\min} &= \frac{-1}{N-1}d_{tol} + D_{N-1} l_{N-1}
\end{aligned} \tag{6}$$

With the precompensation configuration, the minimum set of DCFs is modified as below.

$$\begin{aligned}
(-\bar{d}_1)_{\min} &= \frac{-1}{N-1}d_{tol} + D_1 l_1 \\
(-\bar{d}_2)_{\min} &= \frac{-1}{N-1}d_{tol} + D_2 l_2 \\
&\vdots \\
(-\bar{d}_N)_{\min} &= \frac{-1}{N-1}d_{tol} + D_N l_N
\end{aligned} \tag{7}$$

If we use DCFs for which dispersions are given by Eqs. (6) or (7) depending on the compensation configuration, all of the residual dispersions at each node will be less than or equal to d_{tol} .

2.2. Modular Compensation with Commercially Available DCMs

However, most commercial DCFs are provided in modular form, to compensate for dispersion over a length of 20 km, 40 km, ... 100 km of standard single-mode fiber (G.652); let us denote them DCM20, DCM40, ..., DCM100. Dispersion compensation modules (DCMs) based on fiber-Bragg-grating technology are also provided in a similar manner. Therefore, we can only have a DCM at the i^{th} node for which the dispersion is in the form of

$$\bar{d}_i = k_i \text{DCM}_{\min} \tag{8}$$

where $(-\text{DCM}_{\min})$ is the minimum dispersion of a DCM set available, and k_i is an integer.

DCM_{\min} is usually DCM10 or DCM20, depending on the vendor, and their values at the center of the C band are around -164 ps/nm and -328 ps/nm respectively. If $\text{DCM}_{\min} = \text{DCM20}$ and $k_i = 3$, then \bar{d}_i should be DCM60.

$k_i = 0$ means that no DCM is required at the i^{th} node. Now finding an optimum set of DCMs means finding a set of integers $\{k_i\}_{i=1,\dots,N}$ that will satisfy Eq. (5). First, we can estimate k_i as

$$\tilde{k}_i = \text{round}\left(\frac{(\bar{d}_i)_{\min}}{-\text{DCM}_{\min}}\right) \quad (9)$$

where $\text{round}(x)$ means rounding x to the nearest integer, and $(-\bar{d}_i)_{\min}$ is given by Eqs. (6) or (7).

However, the set of DCMs estimated by Eq. (9) may not make some of the accumulated dispersions in the network below d_{tol} . If that happens, one needs to find the most underestimated $(-\bar{d}_i)$ compared to $(-\bar{d}_i)_{\min}$, and then increase k_i by one until all of the accumulated dispersions are less than or equal to d_{tol} . Numerical examples and discussions follow.

III. NUMERICAL EXAMPLES AND DISCUSSION

To demonstrate the methodology explained in the previous section, let us consider an example 10-node ring network with the postcompensation configuration (Fig. 4). Link lengths are arbitrarily chosen, and the circumference of the ring is 492 km.

Even though the proposed method is not restricted to a specific fiber type or compensation method, it is assumed that standard single-mode fibers are used for transmission and DCFs are used for dispersion compensation, because they are most popular in practice. Properties of commercially available fibers are summarized in Table 1. Parameter values from the table will be used for our numerical demonstration.

The wavelength dependence of the fiber's dispersion parameter is assumed to be linear, so that $D(\lambda) = D(\lambda_0) + S(\lambda_0)(\lambda - \lambda_0)$ ($\lambda_0 = 1545$ nm). The wavelength dependence

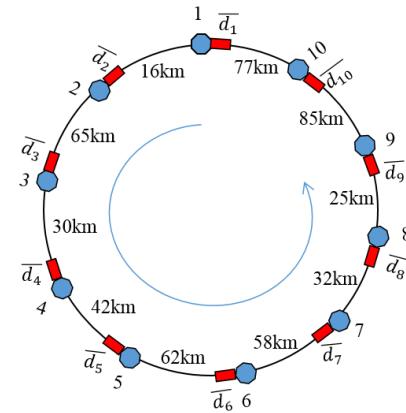

FIG. 4. Example 10-node ring network.

of the DCMs is also modeled linearly, for example, $DCM_{20}(\lambda) = L_{DCM_{20}}\{D_{DCF}(\lambda_0) + S_{DCF}(\lambda_0)(\lambda - \lambda_0)\}$, where $L_{DCM_{20}} = 20 \text{ km} |D_{SSMF}(\lambda_0)/D_{DCF}(\lambda_0)|$. Other DCMs are modeled similarly.

Due to the slope mismatch, a DCF can exactly compensate the dispersion of the transmission fiber only at a single wavelength λ_0 . The slope-compensation efficiency of DCFs is assumed to be 60% ($k_s = 0.6$), which is guaranteed by most commercial products. The effect of the slope mismatch will be most significant at $\lambda = 1565$ nm, which is the longest wavelength in the C band, and therefore the required dispersion of the DCFs should be obtained at $\lambda = 1565$ nm.

3.1. Ideal Compensation with $d_{tol} = 1200$ ps/nm

The dispersions of the DCFs for ideal compensation can be easily obtained by Eq. (6); the results are summarized in Table 2. With these DCFs, all of the dispersion maps at $\lambda = 1565$ nm will end up at d_{tol} at their last nodes.

Figure 5(a) shows three examples of these dispersion maps, and Fig. 5(b) shows the wavelength dependence of the dispersion map from node #2 to node #1, which has the longest path.

TABLE 1. Typical properties of optical fibers

Fibers	@ $\lambda = 1545$ nm	
	Dispersion D [ps/(nm · km)]	Dispersion slope S [ps/(nm ² · km)]
Standard single mode fiber (SSMF) (ITU G.652)	16.5	0.058
DCF	-120	$k_s \frac{D_{DCF}}{(D_{SSMF}/S_{SSMF})}$

TABLE 2. Required dispersions for ideal compensation at $\lambda = 1565$ nm

d_{tol} [ps/nm]	Required dispersions $(-\bar{d}_i)$ at each node (calculated @ $\lambda = 1565$ nm) [ps/nm]									
	1	2	3	4	5	6	7	8	9	10
1200	1226.5	149.2	1014.6	396.5	608.4	961.6	890.9	431.8	308.2	1367.8

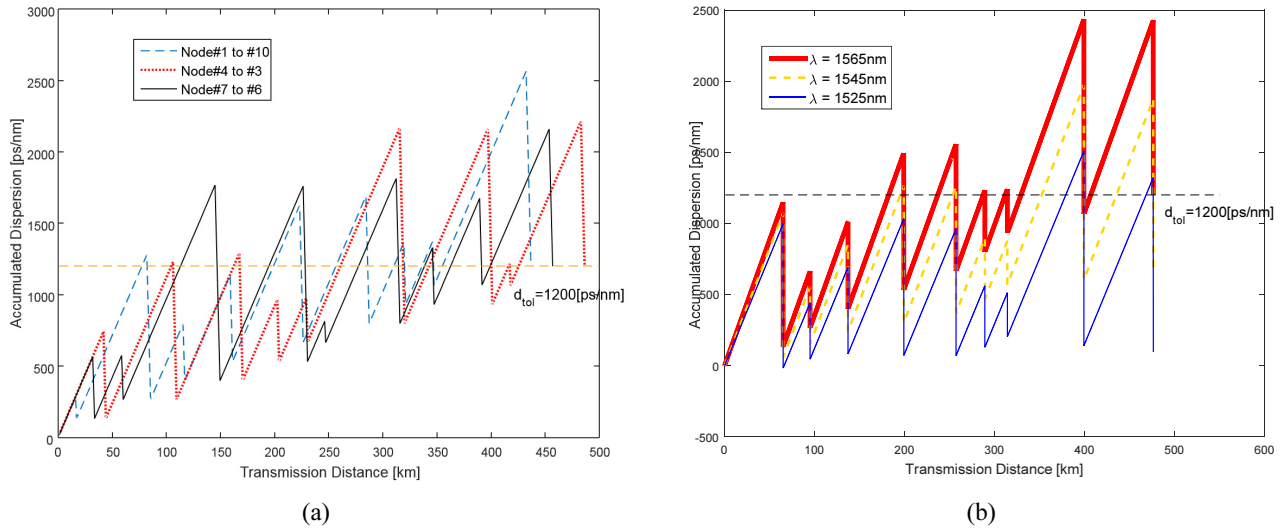

FIG. 5. Dispersion maps using ideal compensation with $d_{tol} = 1200$ ps/nm: (a) 3 maps at $\lambda = 1565$ nm, (b) maps from node #2 to node #1, at three different wavelengths.

3.2. Modular Compensation with Commercially Available DCMs

Now with $DCM_{min} = DCM20$, Eq. (9) gives us $\{k_i\}_{i=1,\dots,N} = \{4, 0, 3, 1, 2, 3, 3, 1, 1, 4\}$ at $\lambda = 1565$ nm. From $\{k_i\}_{i=1,\dots,N}$ we can identify which DCM should be

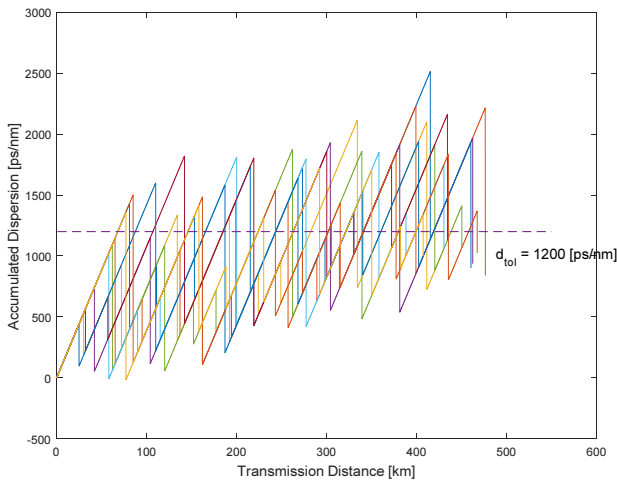

FIG. 6. Dispersion maps at $\lambda = 1565$ nm using $DCM_{min} = DCM20$ with $d_{tol} = 1200$ ps/nm.

placed at the i^{th} node: DCM20 if $k_i = 1$, DCM40 if $k_i = 2$, and so forth. Figure 6 shows the dispersion maps with the identified DCMs at each node. Note that all of the residual dispersions are under d_{tol} . Unlike the ideal-compensation case, the accumulated dispersions at their last nodes are less than d_{tol} .

We can also design a dispersion map with $DCM_{min} = DCM10$, that is, with DCFs in a finer modular form, to compensate dispersion over lengths of 10 km, 20 km, 30 km, ..., of standard single mode fiber.

Now if d_{tol} were reduced to, say, 800 ps/nm, possibly due to increased imperfections of other devices, then we could expect that overall more DCMs would be required. We can identify which DCM should be placed at the i^{th} node as before; the results are in Table 3. With $d_{tol} = 800$ ps/nm, using $DCM_{min} = DCM10$ is a little more favorable compared to $DCM_{min} = DCM20$, since the total amount of dispersion by each DCM is reduced. Figure 7 compares the dispersion maps with $DCM_{min} = DCM20$ and with $DCM_{min} = DCM10$ when a signal travels from node #2 to node #1. If more than one set of DCMs can reduce the residual dispersions below a given d_{tol} , then other aspects of the network design, including the cost of DCMs, should be considered.

TABLE 3. Optimum DCMs for the 10-node ring network

d_{tol} [ps/nm]	DCM_{min}	DCMs at each node										Total DCMs
		1	2	3	4	5	6	7	8	9	10	
1200	DCM20	80	-	60	20	40	60	60	20	20	80	440
	DCM10	70	10	60	20	40	60	50	30	20	80	440
800	DCM20	80	20	60	20	40	60	60	40	20	80	480
	DCM10	70	10	60	30	40	60	60	30	20	80	460

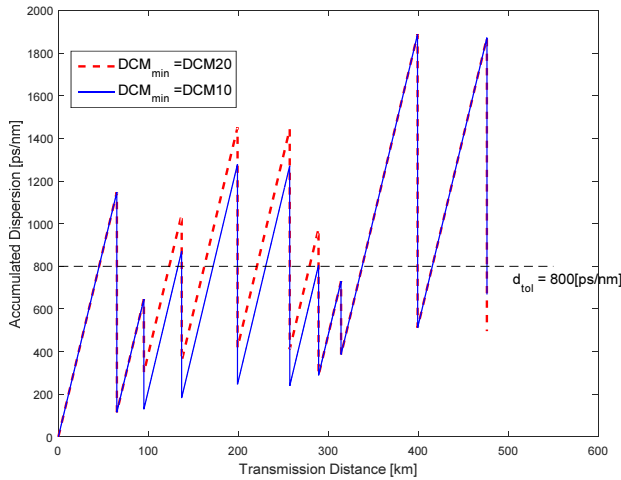

FIG. 7. Comparison of dispersion maps when $DCM_{\min} = DCM_{20}$ and $DCM_{\min} = DCM_{10}$ (from node #2 to node #1, counterclockwise).

IV. CONCLUSION

We propose a simple but powerful methodology to design a dispersion map with an optimum set of DCMs for a WDM ring network. The methodology is restricted neither to a specific fiber nor dispersion-compensation method. In principle, for a given value of the maximum tolerable residual dispersion, it can be used with any modulation format and any bit rate. We apply the methodology to an example 10-node ring network of 492 km circumference and demonstrate how it works. Since no work has been reported to design a dispersion map for a ring network, the proposed method can be a good design tool for a ring network capable of wavelength reconfiguration.

REFERENCES

1. G. P. Agrawal, *Lightwave Technology: Telecommunication Systems* (John Wiley & Sons, Inc., 2005).
2. R. Ramaswami and K. N. Sivarajan, *Optical Networks: A Practical Perspective*, 2nd Edition (2002).
3. S. Ramachandran, *Fiber Based Dispersion Compensation* (Springer 2010).
4. Y. J. Wen and S. Dods "Dispersion map optimisation in WDM transmission systems," in *Proc. 15th Annual Meeting of the IEEE Lasers and Electro-Optics Society* (UK, Nov. 2002), paper Tul2.
5. N. Hanik, A. Ehrhardt, A. Gladisch, C. Peucheret, P. Jeppesen, L. Molle, R. Freund, and C. Caspar, "Extension of all-optical network-transparent domains based on normalized transmission sections," *J. Lightwave Technol.* **22**, 1439-1453 (2004).
6. M. Malach, C.-A. Bunge, and K. Petermann, "Fibre-independent optimum dispersion mapping for SPM and XPM suppression in 10 Gbit/s WDM NRZ optical transmission systems," in *Proc. European Conference on Optical Communications* (France, Sept. 2006), pp. 1-2.
7. T. Alves and A. Cartaxo, "Dispersion map design for XPM suppression in NRZ 10 Gbit/s pre-compensated WDM links using Standard-Fibre and 50 GHz of channel spacing," in *Proc. SBMO/IEEE MTT-S International Microwave and Optoelectronics Conference* (Brazil, Oct. 2007), pp. 648-652.
8. N. M. S. Costa, and A. V. T. Cartaxo, "Influence of the channel number on the optimal dispersion map due to XPM in WDM links," *J. Lightwave Technol.* **26**, 3640-3649 (2008).
9. M. Y. Hamza and I. Hayee, "Performance improvement of 40 Gb/s WDM systems by optimization of dispersion map," in *Proc. IEEE 10th International Conference on Application of Information and Communication Technologies (AICT)* (Azerbaijan, Oct. 2016), pp. 1-5.