

Print ISSN: 1738-3110 / Online ISSN 2093-7717  
http://dx.doi.org/10.15722/jds.17.03.201903.5

# Building a Sustainable Competitive Advantage for Multi-Level Marketing (MLM) Firms: An Empirical Investigation of Contributing Factors

Lee Siew Keong\*, Omkar Dastane\*\*

Received: January 24, 2019. Revised: February 02, 2019. Accepted: March 05, 2019.

## Abstract

**Purpose** - The purpose of this research is to investigate the factors contributing to sustainable competitive advantage for multi-level marketing (MLM) firms in Malaysia. The selected variables in this study are company image, product innovation, leadership, distributor rewards system and distributor training system.

**Research design, data, and methodology** - Quantitative research method is employed with collected sample size of 398 respondents using judgmental sampling technique. Normality and reliability test were performed in the first stage utilizing SPSS 22 and Confirmatory Factor Analysis (CFA) and variance analysis were obtained in the subsequent stage, following up with the overall fit of the measurement model, Structural Equation Model (SEM) using AMOS 22 with maximum likelihood estimation to assess the internal consistency, convergent validity and discriminant validity.

**Results** - The research findings show that company image, leadership, distributor rewards system and distributor training system were supported and are factors affecting the sustainable competitive advantage of MLM companies in Malaysia. However, in this study, product innovation was not supported but this result does not depict that it is trivial and inconsequential in maintain sustainable advantage.

**Conclusion** - Companies can build sustainable competitive advantage by focusing on these contributing factors. Several other comments and implications were brought to light and discussed in the paper.

**Keywords:** Company Image, Distributors Rewards System, Distributors Training System, Product Innovation, Leadership, Multi-Level Marketing, Sustainable Competitive Advantage.

**JEL Classification:** M310, M390.

## 1. Introduction

Multi-Level Marketing (MLM) has a broad definition and sometimes referred as direct selling, network marketing or referral marketing. This business model existed since year 1945 with the dual way of retailing through distributor's network and sponsoring or recruiting new distributors to do the same (Keep & Nat, 2014) and it has been made known

and popularized to public since 1950s with the inception of Amway. MLM is a marketing strategy and platform to promote and sell the company's products and services through a group of non-salaried workforce, which generally called as Distributor, Member, Independent Business Owner, Independent Representative, Agent and etc. Although MLM has created negative perception, ambiguities and innumerable debates due to its legitimacy for the past decades, it undoubtedly has benefitted and contributed to vast diversified groups of people with new opportunities and alternative to earn additional passive income despite of high economic volatility (Borg & Young, 2014).

In recent decades, many foreign-owned MLM companies have chosen Malaysia to setup as first country in Southeast Asia, therefore creating huge competition among homegrown MLM companies. The MLM business is regulated by the Direct Selling Association of Malaysia (DSAM) which adheres

\* Founder & Group Corporate Advisor, SKG Group of Companies, Block K-3-1&3, Pusat Perdagangan Kota Damansara, No 12 Jalan PJU 5/1, Kota Damansara,, 47810 Petaling Jaya, Malaysia.  
E-mail: leesiewkeong26@gmail.com

\*\*Senior Lecturer cum Head - Centre for Postgraduate Studies, School of Accounting & Business Management, FTMS Global Malaysia, Block 3420, Persiaran Semarak Api, Cyber 4, Cyberjaya, Selangor, Malaysia. Tel: +60-10-204-6941 E-mail: omkar.dastane@gmail.com

to the requirement of the Direct Sales and Anti-Pyramid Act 1993. In 2017, MYR13, 650 million has been contributed by Direct Sales Industry to our country economy (data.gov.my). Malaysia also has been in the Top 10 list of Direct Sales Global Market which represents 3% of global sales (WFDSA, 2018). Due to the long MLM history, Malaysia has been chosen as a hub in SEA by foreign owned / international MLM companies for training and developing their executive level employees. For the competitive landscape in Malaysia and based on Euromonitor (2018), the top 13 Direct Sales Company are as follows:

**Table 1:** Top 13 Direct Sales Company in Malaysia

	Name	Country of Origin	Status
1	Amway (M) Sdn. Bhd.	USA	MLM
2	Cosway (M) Sdn. Bhd.	Malaysia	MLM
3	Elken Sdn Bhd	Malaysia	MLM
4	Tupperware Malaysia Sdn. Bhd.	USA	Single Level
5	Hai-O Enterprise Bhd.	Malaysia	MLM
6	Nu Skin Enterprises Inc.	USA	MLM
7	Forever Living Products International LLC	USA	MLM
8	USANA Health Science Inc	USA	MLM
9	Herbalife Ltd	USA	MLM
10	Citra Nusa Insan Cemerlang PT.	INDONESIA	MLM
11	New Image Group Ltd.	New Zealand	MLM
12	Avon Products Inc.	USA	Single Level
13	Mary Kay Inc.	USA	MLM

Source: Euromonitor(2018).

Based on Table 1, from the 13 top, Malaysia only representing just 3. This means that the big piece of sales is generated by Foreign-owned companies and long proven that they have stronger resources and capabilities compared to home-grown companies. Obviously, home-grown are way behind the foreign-owned in certain aspects especially image and reputation, products R&D and technology, management and professionalism (citation). Since 1993 till now, there are 1690 direct selling licences (data.gov.my) issued by Ministry of Domestic Trade and Consumer Affairs Malaysia (Kementerian Perdagangan Dalam Negeri, Koperasi dan Kepenggunaan, KPDNKK) but many has expired and dormant and remaining active number of only 367 as at 2017, breakdown into 288 companies operates in Multilevel and the balance are single level marketing or mail order sales (data.gov.my). This debilitating phenomenon is due to the lack of sustainable competitive advantage and technical aspect of Direct Selling management knowhow. MLM is a

high capital-intensive business model and needed broad range of knowledge and hands on experience to gain competitive advantage and foothold on the market (KPDNKK, 2017). In this state of affair, many entrepreneurs had ventured into the pool together with those novices who wish to gain fortune in this industry. Unfortunately, many home-grown companies in extremes and ceased operation in view of the predicaments and the realistic situation were not what they perceived and reckon on.

As the above Table 1 shows, there are 194 new MLM companies approved by KPDNKK from year 2012 to 2017. However, from Table 4, we can clearly witness that the dropped out, not renewed and discontinued rate is far beyond the approval rate, that is 305 companies (KPDNKK, 2017). These concerns lead to a comprehensive examination of the factors influencing the competitive advantage of MLM companies in Malaysia. Currently, foreign owned MLM companies like Amway, Usana, Herbalife, Nuskin etc. become eminent and keep elevating in revenue, unlike the homegrown MLM companies which weaken in competitive advantage from time to time. According to KPDNKK, report has shown that only small handful of home grown MLM companies have sustained its business beyond 10 years since establishment. In contrary, most of the foreign-owned MLM companies in Malaysia have been established more than 10 years and to the extent of 39 years. Amway which was established in 1976 being the largest foreign-owned MLM companies in Malaysia. Moreover, according to KPDNKK data extracted from Malaysia statistic (data.org.my) as of 2017, Malaysia MLM industry has yielded a total of MYR 6,199 million.

The revenue data of 40 foreign-owned companies has been extracted and consolidated from Companies Commission of Malaysia (SSM), and the total revenue amounting to MYR 4,194 million. It can be clearly seen that foreign-owned MLM companies represent more than 70% of Malaysia MLM industry revenue and they are the predominant player in Malaysia with approximately 81 companies out of total 288 active MLM companies (28%). At this juncture, home-grown is in distress to fortify their position in order to defend their market share. Currently, home-grown MLM companies are facing the pressure from its stakeholders due to direct comparison with successful foreign-owned MLM companies. Therefore, it is imperative for the local MLM companies to maintain its comparative advantages (Oppenheim, Bonini, Bielak, Kehm, & Lacy, 2007). In order to achieve that, local MLM companies are required to identify relevant sustainable factors to achieve longevity so they can be at par with the achievements of prominent foreign-owned MLM companies. Furthermore, due to the rampant growth of illegal MLM schemes and blatant money games in Malaysia, which aggravated the negative impact and further caused deleterious effect on the perception of this industry (KPDNKK, 2017), it is vital for the local MLM companies to attain sustainability. As at today,

not much research has been done pertaining to the sustainable competitive advantage of MLM Company in Malaysia especially home-grown companies. The result of this study will improve understanding of the factors influencing the sustainable advantage of MLM companies in Malaysia and the impact of sustainable advantage will be justified.

In this research, five areas have been identified as the influential factors which affecting the sustainable advantage of MLM companies in Malaysia and these factors are, company image, product innovation, leadership, distributor reward system and distributor training system. By examining these factors, there search aims to contribute better understanding and insights of the interconnection between these factors and sustainable advantage of MLM companies in Malaysia. The main purpose of this research is to identify the factors that influence the business sustainability of MLM companies in Malaysia. Research Question: What is the impact of company image on sustainable competitive advantage of MLM companies' in Malaysia? What is the impact of product innovation on sustainable competitive advantage of MLM companies' in Malaysia? What is the impact of leadership on sustainable competitive advantage of MLM companies' in Malaysia? What is the impact of distributor reward system on business sustainable competitive advantage of MLM companies' in Malaysia? What is the impact of distributor training system on sustainable competitive advantage of MLM companies' in Malaysia?

## 2. Literature Review

### 2.1. Definition of Key Concepts

By definition, sustainability is to "keep the business going", a common term used to refer to "future-proofing" of organisations (Kurucz, Colbert, Lüdeke-Freund, Upward, & Willard, 2017). Sustainability is considered as prevention of resources stretched over some time into the future for organisations to retain their competitiveness (Ghemawat, 1986). It is long lasting, superior business performance that is believed to gain sustainability in the dynamic market hence acquiring competitive advantage over competitors. A study has been carried out by Liu(2013) to examine the relationship between sustainability and competitive advantage and has revealed that sustainable competitive advantage is referred to or best explaining a company's long-lasting success in business and sustainable advantage. According to Porter (2008), a firm is able to offer the same benefits as compared to its competitor at a lower cost (cost advantage) or improved benefits than competitors' products (differentiation advantage) when competitive advantage exists. An organisation can only achieve competitive

advantage in securing customers from rivals and successfully defends against competitive forces (Strickland, 2012).

Hamel and Prahalad (1991), explained that combining complex streams of technology and work activity creates core competence for the company and these core competencies yield long-term benefit to the company and gives birth to sustainable competitive advantage. Competitive strategies can come in the form of high-quality products, superior customer services and achieving lower costs. Competitive strategy can only be identified when the company constantly researched into and predicts the changing or market conditions and customer's needs. The market dynamism and technologies has often been critical of the sustainability of competitive advantage. Wernerfelt (1984) had proposed a model which was improved by Barney, Wright, and Ketchen (2001). This model helps to solve issues related to elements in order to achieve competitive advantage. This model as Resource Based View, explains that "resources" and "capabilities" are required by an organisation to create sustainable high performances. Ray, Barney, and Muhanna (2004) and Barney (1991), supported that resources and capabilities are needed to form the competitive entry barrier. However, they further explained that it is very difficult to determine the precise amount of resources and capabilities needed to provide sustainable position and performance. Hafeez, Zhang, and Malak (2002) stated that the answers are often rooted deep in the organisation. It is influenced by various scenario, and only be presented as differentiated products, efficiencies, quality, innovation, or customer services. According to Srivastava, Franklin, and Martinette (2013), a handful of determinants can greatly influence a company's competitive advantage. These comes in the form of leadership (company vision, mission, leadership, and governance), incentives (reward and performance management systems), organisational culture (corporate of orthodoxies and values), organisational design (organisational structure, globalization, collaboration effects), and organisational systems (strategic planning, information technology infrastructure).

### 2.2. Critical Review of Key Models and Theories

(Humphrey, 2005) SWOT Analysis: This strategy model is a framework which helps to identify the internal factors and external factors on the company's ability to compete. This model lets the companies to identify the most likely and potential products and market strategies systematically by assessing 4 aspects of the company and industry. The 4 aspects are Strengths, Weaknesses, Opportunities and Threats. Strengths: The attributes of a company that assist to strengthen its competitive position, Weaknesses: The attributes of a company that weaken its competitive position, Opportunities: External environmental conditions that favourable in elevating a company's competitive position. Threats: External environmental conditions that unfavourable

and damaging a company's competitive position. This analysis helps in identify the important key factors that imperative to the achievement of the objectives of a company, however, it tends to generate innumerable list of opportunities which the management of a company is difficult to focus on and prioritise the strategic idea in helping the company to achieve its objective. (Porter, 1979) Porter's 5 Forces: Michael Porter has developed 5 forces theory in reaction to the popular SWOT analysis in 1979. This framework attempts to analyse the level of competition within a given industry and assist in developing business strategy. It also assists in the assessment of external environment influences on a company's ability to sustain or gain a competitive advantage. He has redefined all the traditional business theories and introduced new benchmark which comprises of 5 forces: Threats of new entrants, Threats of substitution, bargaining power of buyers, bargaining power of supplier and Intensity of competitive rivalry for determining the strengths and weaknesses of an organization. (Porter, 1979) - Porter Generic Strategies: According to (Porter, 2008), if attractiveness in the industry is the main key determining factor in profitability of a market, then the position it holds in a particular industry is its secondary determinant. There are two types of competitive advantage a company can possess and Porter suggested that the generic strategy can be achieved successfully via cost leadership or differentiation. These two types of competitive advantage combined with the scope of activities in which a company is pursuing, results to three generic strategies: cost leadership, differentiation, and focus. These generic strategies are namely cost leadership, differentiation and focus.

(Barney, 1991) Barney's VRIN: In 1991, Barney has developed a framework called VRIN based on resource-based view. VRIN, valuable, rare, imperfectly imitable and not substitutable resources is vital in creating sustainable competitive advantage. Based on this framework, the resources and capabilities of a company include financial, physical, human and organisational assets. The 4 attributes will be summarised as follows: From the literature review, there are numerous contributing factors and determinants that influence a company's competitive advantage and thus its business sustainability. Also, from the review, the resources and capabilities that a company possess are imperative to determine the competitive differentiation of its offerings and competitive position in the market. As such, it is necessary and important for a company to investigate and identify its resources and capabilities based on resource-based VRIN framework with continuous nurturing effort to create and develop products and services that generate unceasing attraction in targeted market segments for long term business sustainability and sustainable competitive advantage. To identify the combination of resources and capabilities that impact and influence the business sustainability and sustainable competitive advantage of a

company is strenuous and has not been easy as some are causal ambiguous and set deeply in the company. From the literature above, some major factors that are likely to influence and impact an MLM company's business sustainability and sustainable competitive advantage are company image, product innovation, leadership, distributor reward system and distributor training system.

## 2.3. Variables and Hypothesis Definition

### 2.3.1. Company Image on Sustainable Competitive Advantage

An organisation's positive image is of great value to MLM companies. It helps scale down uncertainty and unnecessary transaction costs. A positive reputation is an important ability for building credibility and support amongst stakeholders (Melewar, 2003). The company can obtain society's trust and credibility by building reputational stances (Feldman, Bahamonde, & Velasquez Bellido, 2014). This is a great marketing tool for MLM companies' distributors to increase sales and recruitment for sustainable competitive advantage. As such, first hypothesis suggested that,

**H1:** The company image will have a direct significant impact on business sustainability of MLM companies in Malaysia.

### 2.3.2. Product Innovation on Sustainable Competitive Advantage

Current foreign MLM companies have gained competitive advantage through product innovation. The common traits among these companies are lasting repeat purchase and prioritization of product's unique aspect to achieve differentiation advantage (Gebauer, Gustafsson, & Witell, 2011). MLM companies that emphasizes on R&D provide better products and services in achieving competitive advantages. Foreign companies like Amway, Herbalife, Usana, Young Living, etc has successfully driven innovativeness to increase market share in the country. Product innovation becomes a vital driver of productivity and long-term growth and business sustainability. (Brem, Maier, & Wimschneider, 2016) suggests that it is essential for the company to discover innovative products to accommodate market needs toward achieving competitive advantage. Innovative products increase sales, profits and competitiveness, but often, these products can be expensive and risky to the company. As such, second hypothesis suggested that,

**H2:** Product Innovation will have a direct significant impact on sustainable competitive advantage of MLM companies in Malaysia.

### 2.3.3. Leadership on Sustainable Competitive Advantage

Leadership is important to a company's success (Pfeffer, 1994). Leaders are typically in the most influential position in the company. An effective leader is one who can make an effort to change both the company and people within an organisation. The leaders and followers always work together with others to strike for success. Yukl (2009) said that leadership is the ability to complete the task in achieving goals by changing variety of strategies, plans, responsibilities, affecting a group in order to determine, educate and promote a culture within an organisation. A visionary and strategic leader can construct a motivated workforce and ultimately establishes company's competitive advantage (Ireland & Hitt, 2005). As such, third hypothesis suggested that,

**H3:** Leadership will have a direct significant impact on sustainable competitive advantage of MLM companies in Malaysia.

### 2.3.4. Distributors' Reward System on Sustainable Competitive Advantage

Distributor reward system is an enticement that motivates distributors and is an ability to sustain repeat sales of products/services (Hsieh & Chen, 2011). The assurance of attractive monthly earning is one of the keys to retain distributors in the company (Rowland & Hall, 2014). In MLM context, reward system is the variety of perks and recognition title provided to distributors according to their hierarchy status eg. Amway has many status levels with its unique title and perks (Yelkur & Herbig, 1996). One of the key factors to motivate individual to join MLM is the companies' financial reward system (Crittenden, Crittenden, & Pierpont, 2015). Hence, most companies aim at developing lucrative financial rewards system and other tangible rewards to motivate distributors ultimately creating constant and sustainable growth. As such, forth hypothesis suggested that,

**H4:** Distributors' Reward System will have a direct significant impact on MLM companies' sustainable competitive advantage in Malaysia.

### 2.3.5. Distributors Training System on Sustainable Competitive Advantage

Distributors are required to be competent in selling and sponsoring skills to captivate potential member. It's one of the factors leading to success in the competitive market (Swarnalatha & Prasanna, 2013). Hence, quality training program is an essential to all distributors concerning to strengthen their competency (Finch, Peacock, Levallet, & Foster, 2016; Khandekar & Sharma, 2005). Proficiency of knowledge, confidence and skills exhibit key components in recruitment strength while giving confidence to customers and down lines. Adequate trainings and meetings are

important to promote the distributor's success rate. Normative basis of trainings, meetings, workshops and activities with distributors is the primary approach to create social connections among distributors. In MLM, distributors are the primary asset of the company considering their skillsets and active roles they take in contributing to the company's success. They are also perceived as a source of sustainable competitive advantage. As such, fifth hypothesis suggested that,

**H5:** Distributors' Training System will have a direct significant impact on sustainable competitive advantage of MLM companies in Malaysia.

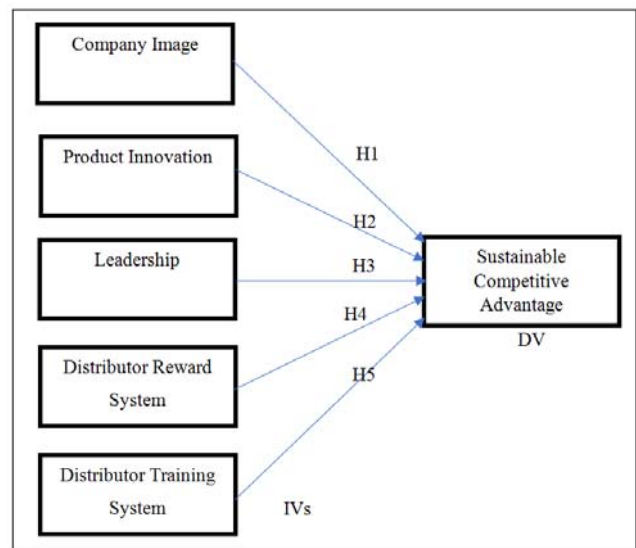

**Figure 1:** Conceptual Framework (Source: Researchers' Development)

## 3. Research Methodology

In this study, explanatory research design is used to investigate relationships between variables (company image, product innovation, leadership, distributor's rewards system and distributor's training system) and independent variable pertaining sustainability of MLM companies. Cross sectional design is conducted in this research as data is collected at a single point in time and variables are represented in a cross section of the population. Survey questionnaire is used for primary data collection. The distribution of survey questionnaire to participants are sent electronically through internet and traditionally hard copy. For electronic distribution, google form is used and the survey data is stored. This is a convenient way for the participants as the questionnaire is available online and real time. For hard copy distribution, the printed survey questionnaires are distributed through direct distribution association to distribute to their associates and associates' distributors, and also going through a few MLM distributor leaders from different

MLM companies in Malaysia. This structured survey questionnaire is in 3 languages, English, Bahasa Malaysia and Chinese for better understanding and reduce the ambiguity regarding the survey questions for participants. All participants' identities are kept confidential in this study.

The research instrument used is self-administered according to the variables adopted and do not require interviewer in presence to facilitate and invigilate the survey. The survey questions are developed based on the previous research which has been done by other researchers, thus it improves the reliability of the research questions. The participants are given each a set of identical questions which is close-ended and scale-response questions to choose from. As mentioned earlier, the data instrument is in multi-lingual due to Malaysia's multi-culturalism and this will reduce the language barrier issue and promote wider participants coverage. The survey questionnaire is divided into 2 sections. Section A is pertaining to participant personal and background information which related to MLM industry. This section covers demographic data such as, race, age, gender, occupation, marital status and income. Section B is related to the questions to gather information pertaining to participant's opinion based on the identified variables towards the MLM companies in Malaysia. The survey questions were designed base on 6 variables; business sustainability, company image, product innovation, leadership, distributor's rewards system and distributor's training system. Questionnaires tools used in this survey is the Likert-scale which seek to determine participants' attitude towards a particular subject through a 5-point scale ranging from "strongly agree" to "strongly disagree" with "neither agree nor disagree" in the middle.

Before the survey is conducted, a pilot test is carried out to ensure the quality of the questionnaire. It is a pre-test study and through the pilot test, the researcher is able gather feedback and amend if necessary, prior to the full-scale survey. Data is obtained and generated from small group of participants and tested in order to identify the flaw, limitation and unanticipated error and misconception of the questionnaires. However, the pilot test may not fully reflect the final survey results. In this pilot study, 20 sets of questionnaires were distributed to 20 participants before full-scale survey is conducted to the manager level and above executives and distributors of one MLM company in Malaysia, Return Legacy Sdn Bhd. In this paper, the objective is to identify the determinants that affect the competitive advantage of MLM companies in Malaysia. According to WFDSA (2018) annual report, there is approximately 4.25 million direct selling (single level and multi-level) distributors in Malaysia. Hence, target population group will be selected based on the position of manager level or above and distributors of MLM companies in Malaysia who is Malaysian with age of 18 years old and above (Stated by Direct Sales Act 1993 as legal age to join) regardless of gender, race, part-time or full-time. This

target population group is the correct group as they understand and comprehend about the nature and structure of MLM business and its environment.

For the sample size in this research, the rule-of-five technique for sample selection is adopted (36 items multiply with 5) that is minimum of 180 samples which fit as sampling population. For this survey, the questionnaires distribution will be double up to the different MLM companies' distributor leaders in hard-copy format and for electronically (google form), a link is provided through social media to invite more respondent to participate in the survey. Finally, total of 526 questionnaires were received and after filtering, only 398 questionnaires were fit and possible to be used as sampling population in this research. Snow ball sampling also applied in this survey as the leading distributor in MLM companies might invite other distributors in their company's network. This sampling method will increase the precision and accuracy to the correct target population due to the close-knitted connection among distributors in MLM industry. The data was collected from October 2018 till December 2018. After completion of data collection, various statistical data analysis methods is used to determine the relationship between variables via Statistical Package for Social Science (SPSS). The data analysis plan in this research covers descriptive analysis, normality analysis, reliability test utilising SPSS 22. Confirmatory Factory Analysis (CFA) and variance analysis were obtained in the subsequent stage. In order to determine the overall fit of the measurement model, Structural Equation Model (SEM) was developed using AMOS 20 with maximum likelihood estimation to assess the internal consistency, convergent validity and discriminant validity.

## 4. Results and Discussion

Reliability and normality test were performed in the first stage utilising SPSS 22. Confirmatory Factory Analysis (CFA) and variance analysis were obtained in the subsequent stage. In order to determine the overall fit of the measurement model, Structural Equation Model (SEM) was developed using AMOS 22 with maximum likelihood estimation to assess the internal

### 4.1. Pilot Test and reliability statistics

Scrutiny was done by the researchers in the refinement process of the pilot questionnaire. In regard to the questionnaire, limited sample size of participants from the target population was involved in the trial run of the instrument in order to weed out main problems during pilot testing (Mahotra, 2010). The pilot study involved a limited number of participants (n=20). The sample of the pilot study were drawn from participants which is from the same population. On a side note, the main study does not include these participants.

**Table 2:** Reliability Test for Pilot Test

Variables	Number of items	Cronbach's Alpha
Sustainable Competitive Advantage	6	0.691
Company Image	6	0.833
Product Innovation	6	0.705
Leadership	7	0.715
Distributor Reward System	5	0.698
Distributor Training System	6	0.868
Total	36	0.854

The participants for this pilot test were top leaders and management of MLM companies which were drawn from the same population. However, these participants were not part of the main study. The reliability test had been conducted on each variable. In testing the reliability, Cronbach's Alpha suggested to be more than 0.6 for each variable shown satisfactory indicator (Gliem & Gliem, 2003). As shown in the table 8 above, the measurement then can be summarized for the total of variable once each variable has been proved that the value of Cronbach's Alpha is more than 0.6. For this research, total items for all variables are 36 were adopted, the current research will measure all variable and the value is 0.854, which indicates a high level of internal consistency and reliable for the scale, and further data collection can be proceed. Although Cronbach's Alpha shown is satisfactory, the items required some mending as shown in Table 2 summarises the procedures of selecting best fit items at the pilot stage. The table illustrates the number and reason of items that were dropped from the questionnaires.

#### 4.2. Descriptive Statistics

Table 3 displays descriptive statistics. The total number of 398 respondents is consisting of 166 male and 232 female respondents which is equivalent to 41.7% and 58.3% respectively. A dominant percentage of 55.5 % are from the age group of 28-37 years old according to the data. Middle age group of 38-47 years old have contributed 23.9% to the respondent sample following with 20.4% from the young age group of 18-27 years old. Based on the figure, a staggering amount 69.8% are married individuals following with 27.6% of respondent with single status. A minimal percentage of

2.5% respondents declared to be divorced. Chinese, Malay, Indian and others are categorised separately into 4 categories of respondents in this research. The category of "Others" includes other minority race such as Sikhs and other indigenous natives. In this sample, Chinese make up a majority total percentage of 87.2% of the total respondents whereas the remaining 4.3% Malay, 4.0% Indian and 4.5% belongs to "others". Three categories of occupation are categorised in the data collection. Occupation class of Management/Employee from MLM Company contributed 13.6% from the total respondents. The remaining respondents of part-time MLM-er or distributors encompassing 272 respondents followed by 72 full-time distributors stands at the percentage of 68.3% and 18.1% respectively. From the total respondents, 80.5%(214 respondents) earns MYR 5,000 or below. 16.2%(43 respondents) earns in between MYR 5,000 to MYR 10,000. Lucrative earnings of MYR 10,001 to MYR 20,000 shows 2.3%(6 respondents). Only 1.1%(3 respondents) earns a staggering income of above MYR 20,000. The above demographic profiles substantiate a finding of female majorities among the participating respondents with a part-time occupation in MLM Company. These respondents fall under the monthly income group of below MYR 5,000.00.

#### 4.3. Normality Test

The determination on whether the sample data reflects normal distribution together with the independent and dependent variable's probability is administered by using Normality test with SPSS software. As the sample size is more than 50, The D'Agostino's K2test is used on the 300 collected respondents, the skewness and kurtosis are analysed in its calculation from the respective respondents. According to Guo, Duff, and Hair (2008) rule of thumb, ideally the values of kurtosis and skewness should be between -1 to +1. The verification of the data set is still deemed as normal univariate distribution even if both the values are in the range of -2 to +2, under this circumstance, it is still considered to be acceptable. In the results from the surveys conducted with D'Agostino's K2 test, the skewness column containing all the statistical values falls into the range of -2 to 2 which are of the acceptable range, therefore, the consideration that the collected data is of normal distribution in this study.

**Table 3:** Items dropped Process in the Pilot Stage

Variables	No. of items	Samples size	No. of Dropped Items	Reason items were dropped
Sustainable Competitive Advantage	From 10 to 6	20	4	Item-to-total correlation was too low at 0.383 for items 'A2', 'A4', 'A6' and 'A9'. Items deleted resulted in increased Cronbach Alpha.
Company Image	6	20	0	No item dropped.
Product Innovation	6	20	0	No item dropped.
Leadership	From 9 to 7	20	2	Cronbach Alpha increased as items 'D1' and 'D8'.
Distributor Reward System	5	20	0	No item dropped.
Distributor Training System	6	20	0	No item dropped.

#### 4.4. Reliability Analysis

It is crucial to ascertain the reliability in statistical analysis on the consistency of the overall data set and whether similar outcomes are produced in a consistent manner, then only the set of data is considered to be of high reliability (Trochim, 2006). Reliability test is used to assess the stability and consistency of the results produced from the set of data. Cronbach  $\alpha$  (Cronbach's alpha test), CR (Composite Reliability test) and AVE(Average Value Extracted test) are the 3 methods utilised to test the reliability in this study. The questionnaires contain multiple questions utilising Likert scale, hence the reliability is measured with Cronbach's alpha test as it is deemed to be the most prevalent measure to determine the suitability and consistency of data (Rackwitz, 2001). The positive correlation among the set of items reflects the coefficient of reliability. According to Gliem and Gliem (2003), from the viewpoint of data consistency, Cronbach's alpha scoring of 0.7 is regarded as unacceptable, questionable or poor and scoring of 0.9 or above is deemed to be excellent.

**Table 4:** Overall Cronbach's Alpha Score (SPSS)

Reliability Statistics	
Number of Items	Cronbach's Alpha
36	0.973

**Table 5:** Cronbach's Alpha Score (Score)

Reliability Statistics		
Variables	Number of Items	Cronbach's Alpha
Average for all variables	6	0.949
Business Sustainability	6	0.872
Company Image	6	0.923
Product Innovation	6	0.917
Leadership	7	0.933
Distributor Reward System	5	0.883
Distributor Training System	6	0.946

#### 4.6. Accuracy Analysis Statistics

**Table 6:** Accuracy Analysis Statistic

Construct		Items	Factor Loadings	Cronbach's Alpha Value	CR	AVE	MSV
A	Business Sustainability (BS)	BS 1	0.797	0.857	0.860	0.554	0.526
		BS 2	0.831				
		BS 3	0.626				
		BS 4	0.764				
		BS 5	0.683				
B	Company Image (CI)	CI 1	0.856	0.864	0.867	0.684	0.484
		CI 2	0.842				
		CI 6	0.782				
C	Product Innovation (PI)	PI 1	0.731	0.877	0.880	0.647	0.598
		PI 2	0.802				
		PI 4	0.857				
		PI 6	0.822				

From the observation of the overall Cronbach's alpha scoring of 0.973 from the 36 items in Table 4, it indicates an exceptionally high reliability and internal consistency in reflecting our scale.

In regard to internal consistency, Table 5 portrays a highly reliable figure. The Cronbach's alpha test is carried out with 1 dependent variable and 5 independent variables, producing an average score of 0.949 in the reliability test. The reward system of distributor comes with a scoring of 0.883 which falls under the bracket of  $0.9 > \alpha \geq 0.8$  which signify satisfactory internal consistency and reliability. As for training system of distributor, product innovation, company image and leadership, all of these come under bracket of  $\alpha \geq 0.9$ , which is deemed as excellent in Cronbach's alpha reliability test. In reference to Table 5, the reliability test for business sustainability produces a Cronbach's alpha scoring of 0.872. This scoring falls under good internal consistency and reliability, with a depiction of high reliability in internal consistency.

#### 4.5. Composite Reliability Test

In the measurement of internal consistency, CR (Composite reliability) coefficient is the following measure. According to Chin (1998), the equality of all indicators are not assumed in CR coefficient. The "modest" composite reliability is capped at a CR value of 0.70 and it is interpreted similarly as Cronbach's alpha (Peterson & Kim, 2013). The CR results of the measurement model used in testing the internal consistency are shown in Table 21 with a CR range of 0.85 to 0.92. The reliability of the scale is shown by the level of CR coefficient, whereby the higher the level of CR coefficient, the higher the reliability is. The CR indices are demonstrated with high indicators in the table. The results of all CR values surpassed the recommended threshold of 0.7 (Peterson & Kim, 2013), hence confirming the reliability of the measures used in this study.



D	Leadership (LD)	LD 1	0.836	0.846	0.847	0.650	0.598
		LD 3	0.820				
		LD 5	0.760				
E	Distributor Reward System (DR)	DR 1	0.862	0.890	0.894	0.679	0.529
		DR 2	0.866				
		DR 3	0.847				
		DR 5	0.711				
F	Distributor Training System (DT)	DT 1	0.865	0.927	0.930	0.768	0.507
		DT 3	0.895				
		DT 4	0.923				
		DT 5	0.819				

#### 4.7. Average Variance Extracted

In Table 6, the overall amount of variance indicated in the indicators are accounted for by the latent construct for the AVE estimates. The robustness of the latent construct is represented by indicators with higher value of AVE (0.40 or above). Primarily, all AVE values obtained are above 0.4, which is considered acceptable (Fraering & Minor, 2013). The reliability of the research scales is of acceptable levels and is evidently shown in the results. The internal consistency of the scales is shown in the estimates suggested to be consistent when Cronbach's alpha, Composite Reliability and alongside AVE are computed.

#### 4.8. Validity Tests

##### 4.8.1. Root mean square error of approximation (RMSEA)

The error of approximation in the population is accounted by root mean square error of approximation. The value shows how well the model is able to, in an optimally known selected parameter, fit the covariance matrix of the population if available (MacCallum, Browne, & Sugawara, 1996). In principle, RMSEA is treated as a good model fit if the value is equal to or less than 0.5 and is considered an adequate fit when the value is less than or equal to 0.8 (Blozis & Cudeck, 1999). The model's index is sensitive to the estimated parameters number due to the discrepancy measurement by RMSEA which is expressed in degrees of freedom (df). The population's error of approximation is calculated with the robust measure of RMSEA. In Section 4.8, the discussion of the results and the model fit assessment indices are shown.

##### 4.8.2. Convergent Validity

The checking of individual item loadings for all comparable research construct on whether they are matching with or more than the recommended value of 0.5 are done in order to assess the convergent validity. The factors loadings ranging from 0.626 to 0.923 were elucidated in Table 6 on the previous section. The demonstration of some common convergence points and acceptable individual item

convergent validity was indicated by each item variance that was shared with its respective construct of having more than 50% as all items shown a loading factor of 0.5 and above. On further note, the convergence of variables at certain point are signified by CR values greater than 0.7 (Hair, Celsi, Money, Samouel, & Page, 2015). The high convergent validity of the latent variables is shown in Table 21 as the AVE values are above 0.5. The scale item's convergent validity is supported and proved by all the above evidence.

##### 4.8.3. Discriminant Validity

The validation of research construct's discriminant validity is assessed by whether the MSV(Maximum Shared Squared Variance) were lesser than the AVE(Average Variable Extract) value. AVE value is required to be greater than MSV results in order to prove the discriminant validity (Hair et al., 2015). The confirmation of discriminant validity is evident in Table 6 as the research construct shows that the MSV values are lower than the AVE values.

##### 4.8.4. Conceptual Model Fit Assessment

The proposed conceptual model was assessed and done by using the same set of data. According to an argument by (Anderson & Gerbing, 1988), the confirmation of the multiple-item construct measure's accuracy must be done with CFA (Confirmatory Factor Analysis) before testing the hypothesis. AMOS, a confirmatory factory analysis model was used in this assessment. The specification of the observed measure's relations to their posited underlying constructs are done with AMOS as it allows the constructs the freedom of inter-correlation. To reflect more accurate resultant scale accuracy and an acceptable fit, elimination process was done in the validation of initial specification; items below the recommended 0.5 value were eliminated as per Table 6. The result of CFA as shown in Figure 2. Chi-square value over degree of freedom value between 1 and 3 ( $X^2/df$ ), CFI(Comparative Fit Index), GFI(the Goodness-of-fit Index), IFI (Incremental Fit Index) of 0.9 equivalent or greater, and finally the equivalent value of 0.08 or lesser of the Root Mean Square Error of Approximation (RMSEA) value were used to specify the acceptable model fit.

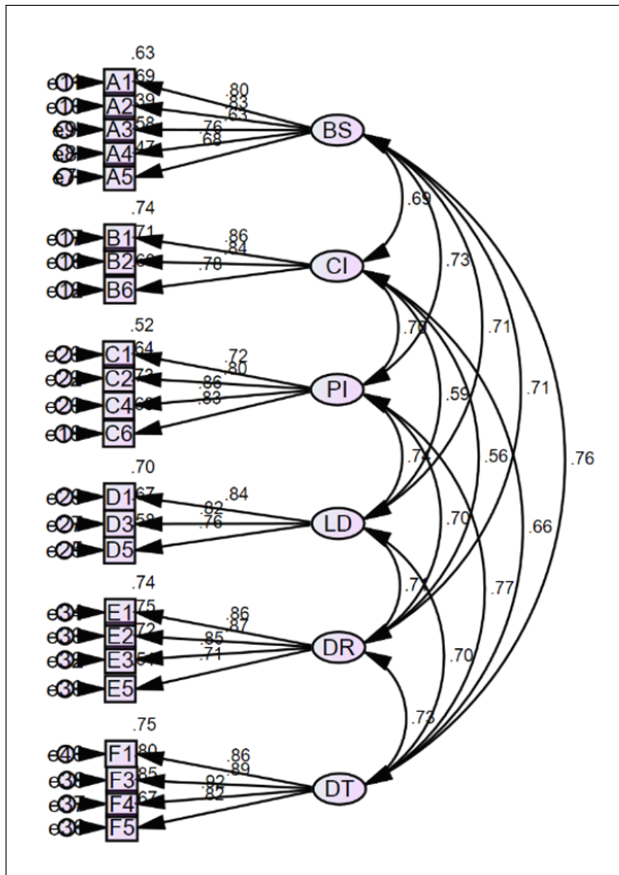

Figure 2: CFA Path Diagram

As seen from Table 7, conclusion can be drawn that the final overall model fit assessment values are within the statistical recommendation based on the observation of overall data that fits the model within reason (CFA model fit results). All indicators depict an acceptable fit for the dataset

Table 7: Summary CFA Model Fit Results

CFA Indicator	Chi-Square	GFI	CFI	IFI	TLI	RMSEA
Acceptance Level	< 3.00	> 0.900	> 0.900	> 0.900	> 0.900	< 0 .08
Default Model Value	2.063	0.907	0.965	0.965	0.959	0.052
Decision	Acceptable	Acceptable	Acceptable	Acceptable	Acceptable	Acceptable

Table 8: Summary of SEM Model Fit Results

CFA Indicator	Chi-Square	GFI	CFI	IFI	TLI	RMSEA
Acceptance Level	< 3.00	> 0.900	> 0.900	> 0.900	> 0.900	< 0 .08
Default Model Value	2.080	0.908	0.965	0.965	0.958	0.052
Decision	Acceptable	Acceptable	Acceptable	Acceptable	Acceptable	Acceptable

of the measurement model. A scoring of 2.063 for Chi-square value over degree-of-freedom, 0.907 (GFI), 0.965 (CFI), 0.965 (IFI), 0.959 (TLI), and 0.052 (RMSEA) are shown in the measurement model. This study proceeds to the testing of the hypothesis as the CFA measurement of model fit values was presumed acceptable.

#### 4.9. Structural Equation Modelling (SEM)

The following figure was developed with AMOS version 20 in the research testing and calculation of the structural model. The structural model testing of this research was done by AMOS version 20 in Figure 3. The model is deemed to be in the acceptable range of goodness-of-fit with the model fit results as per Table 24. The following results of CMIN/DF value <3; RMSEA value ≤0.080; GFI, TLI and CFI value ≥0.90 indicates that the model fit is acceptable. CMIN/DF (2.080), GFI (0.908), CFI (0.965), IFI (0.965), TLI (0.958) and RMSEA (0.052) were the test result of the study. The achievement of the threshold is suggested with the results being in the acceptable range (MacCallum et al., 1996), it implicates that the model is well converged and the SEM model being in an acceptable level fitting to the data and data structure that is collected and gathered in Malaysian setting.

BS(Business Sustainability), CI(Company Image), LD (Leadership), DR(Distributor Reward System), DT(Distributor Training), X<sup>2</sup>/df=2.080, GFI=0.908, CFI=0.965, IFI=0.965, TLI=0.958, RMSEA=0.052. The investigation of the construct exhibits the direct effects amongst the constructs as can be seen in the parameter estimates of the structural model. Significant relationships among the latent constructs are shown based on the significant coefficients from the output revealed above. The proposed research hypothesis is shown to be acceptable and supported by the CFA and SEM model fit results.

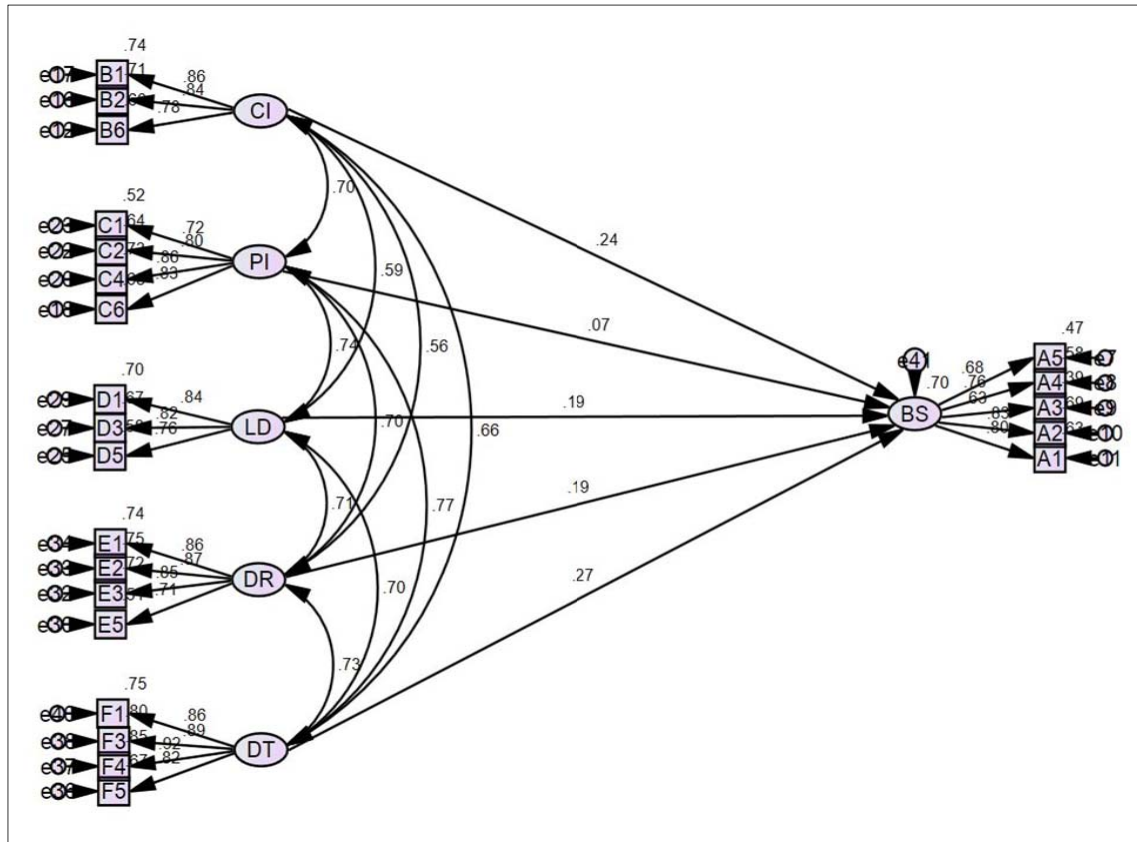

Figure 3: Model Structure Path Diagram

4.10. Hypothesis Testing Result

Table 9: Standardised Regression Weight of the Model

	Dependent Variable		Independent Variables	Estimates B	p	Hypothesis Decision
H1	Business Sustainability	←	Company Image	.24	***	Supported
H2	Business Sustainability	←	Product Innovation	.07	.415	Not Supported
H3	Business Sustainability	←	Leadership	.19	**	Supported
H4	Business Sustainability	←	Distributor Reward System	.19	**	Supported
H5	Business Sustainability	←	Distributor Training System	.27	***	Supported

\*p<.05, \*\*p<.01, \*\*\*p<.001

5. Discussion of Findings

This hypothesis is supported and valid as shown in the Table 9 that the sustainable competitive advantage of MLM companies in Malaysia is positively influenced by the company image ( $\beta=.24$ ,  $p<0.001$ ). Meaning to say, there will be an increase of 0.24% in business sustainability when the company image is increased by 1%. This result similar to the research done by Percy, Rolando, and Isabelle (2014) that positive reputational stance can help the organisation obtain trust and credibility in society, and a positive reputation is an important ability for building credibility and

support amongst stakeholders (Melewar, 2003). Therefore, H1 is supported. This research finding make it clear that product innovation does not create major impact and carries insignificant impact in building sustainable competitive advantage of an MLM company ( $\beta=.07$ ,  $p>0.05$ ). In other words, there is no impact of innovative in product in the context of MLM Industry Malaysia. This research differed with the research findings by Urbancová and Linhartová (2011) that innovations are a key source of a competitive advantage that determines the economic success of each organisation. Therefore, H2 is not supported.

This hypothesis is supported as according to the findings

in Table 9, it observed that leadership ( $\beta=.19$ ,  $p<0.01$ ) has positively affected the building sustainable competitive advantage of MLM companies in Malaysia. This shown that a percent increase in leadership quality would cause an MLM organisation sustainable advantage to increase by 0.19%. Leaders are typically in the most influential position in the company and lead to company success. According to Hitt, Ireland, and Hoskisson (2013), strategic leaders are those committed to nurturing people and supporting company's activities in order to create value for stakeholders. This has been supported by Hitt, Hoskisson, and Ireland(1990) that a strategic and visionary leader can construct a motivated workforce in ultimately established company's competitive advantage. Therefore, H3 is supported. The sustainable competitive advantage of MLM business is positively influenced by distributor reward system ( $\beta=.19$ ,  $p<0.01$ ). An increase of 0.18% is experienced when there is an increase of 1% of distributor reward system. Reward system is an enticement that motivates distributors and is an ability to sustain repeat sales of products/services. The assurance of attractive monthly earning is one of the keys factors to retain distributors and ensuring the selling and sponsoring activities of distributors in the company. This also supported by Crittenden et al. (2015) that one of the key factors to motivate individual to join MLM is the companies' financial reward system. Therefore, H4 is supported.

The distributor training system has a positive impact on the MLM companies' sustainable advantage ( $\beta=.27$ ,  $p<0.001$ ). The sustainable advantage of an organisation will be strengthened by 0.27% when the distributor training system increases by a percent. In MLM industry, distributors are the primary asset of the company considering their skillsets and active roles they take in contributing to the company's success. Hence, distributors are required to be competent in selling skills to captivate potential member. It's one of the factors leading to success in the competitive market. This result is corresponded to the research done by Liu (2013) that quality training program is an essential to all distributors concerning to strengthen their competency, and thus building sustainable advantage. Therefore, H5 is supported. In general, based on the overall hypothesis testing and findings, out of five proposed hypotheses, the one not supported and exceptional is the product innovation which indicates insignificant impact on sustainable advantage of MLM companies in Malaysia. Other four hypotheses are supported namely company image, leadership, distributor reward system and distributor training system which produce positive significant impacts on sustainable advantage.

## 6. Conclusion

Based on the results, company image can be considered as the paramount variable for Malaysia's MLM firms'

sustainable advantage. The findings also show that product innovation does not create major impact and carries in significant impact in building sustainable advantage of an MLM company. Almost all MLM companies wish to obtain and market their "core and unique" products for creating unique differentiation among rivals. However, in reality, this situation barely can be achieved in Malaysia, as majority of the home-grown MLM companies' products are sourced from either foreign or local OEM factories. With this disadvantage, the home-grown are difficult to sustain the unique products position due to the products supplied by OEM factories without exclusivity and the factories might supply the similar products to different MLM companies concurrently in the same marketplace. This leads to majority of home-grown to focus towards the distributor compensation plan and fast earning scheme instead of product orientated. Further with majority of Malaysia MLM companies are mostly carrying Dietary Supplements products which by its nature not necessary to be trendsetter and more emphasize on "concept". Malaysian MLM distributors perceived "authentic" product innovation (not conceptual) as those products which are expensive, complicated and difficult to sell, sharing and teaching to their downlines. In addition, from research dataset income data Table 16, nearly 81% of respondent are below MYR 5,000 and this income group will tend to choose cheaper alternative as compared to high price innovative products. As such, product innovation has been perceived by the collected dataset for this research paper as insignificant in creating impact to sustainable advantage.

It is further observed that leadership has positively affected the sustainable advantage of MLM companies in Malaysia. In MLM industry, the independent distributors are the company's sales force by selling the products to consumers or buying the products at distributor's price for own consumption. On the other hand, distributors are highly looking forward to the stability and brighter future of the company by ways of their strategic and visionary leaders as leaders are typically in the most influential position in the company and lead to company success. Leaders in MLM companies need to possess transformational leadership characteristics (Finch et al., 2016) and authentic leadership who comprised of moral behavior and ethically accountable to evolve continuously through relationships with followers and peers (Wernerfelt, 2013). Distributors' rewards system or compensation plan is one of the key factors that motivates independent distributors and to ensure the distributors to strive forward and achieving sales target. In MLM industry, distributors are the primary sales force of the company and relevant training and meeting is needed in order to increase the success rate of product selling and sponsoring downlines. Hence, distributors are required to be competent in selling, sponsoring and servicing skills to captivate potential customers and distributors and retain them in their network group. Proficiency of knowledge, confidence and skills exhibit are key components in selling and recruiting strength while

giving confidence to down lines and customers.

Quality of leadership is the crucial in the overall business engineering process of an MLM companies as leaders of the company are with full autonomy and power to execute what is right for their independent distributors and setting the direction of the company. All company with multitier agent/member/distributor business model must comply with the governing authorities, KPDNKK to protect the MLM industry from negative public perception which embedded in thoughts that MLM is a scam and illegitimate business. An MLM company is needed to maintain positive company image in order to pursue long term sustainability. As MLM is the intensive competitive market with daily "mouth to mouth" activities, it tends to create unwanted "mouth war" by distributors of different companies. Therefore, the distributors need to be educated ethically not to contempt or condemn anything related to other companies. At the same time, positive product image can be enhanced through collaboration with government research centre such as SIRIM and UNIPEQ.

## 7. Limitations & Future Research

In terms of limitations and future research, it is suggested to gather more data from different sizes of MLM companies for future research including companies that focus on different races as Malaysia is a multi-ethnic and multi-cultural country. It can be clearly seen that Chinese-owned companies tend to attract more Chinese distributors, and this similarly happened to Malay-owned companies due to the distinctive culture. This might be another method to gather more comprehensive information on factors that influence the sustainable advantage of MLM Company in Malaysia. Besides, also suggested to differentiate the data gathering process into Foreign-owned and home-grown companies. In this way, the relevant separated data can be gathered from distributors who actively participate in foreign and home-grown MLM companies. These separate data could give further insights on how foreign/home-grown companies' distributors perceived on the sustainable advantage issue of MLM in Malaysia. For future research, it is also suggested to add in mediating variables or more variables which might influence the sustainable advantage of MLM companies in Malaysia, with further analysis on distributors' behavior, distributors' leadership and needs.

## References

- Anderson, J. C., & Gerbing, D. W. (1988). Structural Equation Modeling in Practice: A Review and Recommended Two-Step Approach. *Psychological Bulletin*, *103*(3), 411-423. <https://doi.org/10.1037/0033-2909.103.3.411>
- Barney, J. (1991). 1991 Firm Resources and Sustained Competitive Advantage. *Journal Of Management*, *17*, 99-120. <https://doi.org/10.1093/icesjms/fss178>
- Barney, J., Wright, M., & Ketchen, D. J. (2001). The resource-based view of the firm: Ten years after 1991. *Journal of Management*, *27*(6), 625-641. [https://doi.org/10.1016/S0149-2063\(01\)00114-3](https://doi.org/10.1016/S0149-2063(01)00114-3)
- Anderson, J. C., & Gerbing, D. W. (1988). Structural Equation Modeling in Practice: A Review and Recommended Two-Step Approach. *Psychological Bulletin*, *103*(3), 411-423. <https://doi.org/10.1037/0033-2909.103.3.411>
- Barney, J. (1991). Barney, J.B. 1991 Firm Resources and Sustained Competitive Advantage *Journal Of Management*, *17*, 99-120. <https://doi.org/10.1093/icesjms/fss178>
- Barney, J., Wright, M., & Ketchen, D. J. (2001). The resource-based view of the firm: Ten years after 1991. *Journal of Management*, *27*(6), 625-641. [https://doi.org/10.1016/S0149-2063\(01\)00114-3](https://doi.org/10.1016/S0149-2063(01)00114-3)
- Blozis, S. A., & Cudeck, R. (1999). Conditionally Linear Mixed-Effects Models With Latent Variable Covariates. *Journal of Educational and Behavioral Statistics*, *24*(3), 245-270. <https://doi.org/10.3102/10769986024003245>
- Borg, S. W., & Young, L. (2014). Continuing the evolution of the selling process: A multi-level perspective. *Industrial Marketing Management*, *43*(4), 543-552. <https://doi.org/10.1016/j.indmarman.2014.02.013>
- Brem, A., Maier, M., & Wimschneider, C. (2016). Competitive advantage through innovation: the case of Nespresso. *European Journal of Innovation Management*, *19*(1), 133-148. <https://doi.org/10.1108/EJIM-05-2014-0055>
- Crittenden, W. F., Crittenden, V. L., & Pierpont, A. (2015). Trade secrets: Managerial guidance for competitive advantage. *Business Horizons*, *58*(6) 607-613. <https://doi.org/10.1016/j.bushor.2015.06.004>
- Feldman, P. M., Bahamonde, R. A., & Velasquez Bellido, I. (2014). A new approach for measuring corporate reputation. *Revista de Administração de Empresas*, *54*(1) 53-66. <https://doi.org/10.1590/S0034-759020140102>
- Finch, D. J., Peacock, M., Levallet, N., & Foster, W. (2016). A dynamic capabilities view of employability: Exploring the drivers of competitive advantage for university graduates. *Education and Training*, *58*(1) 61-81. <https://doi.org/10.1108/ET-02-2015-0013>
- Fraering, M., & Minor, M. S. (2013). Beyond loyalty: Customer satisfaction, loyalty, and fortitude. *Journal of Services Marketing*, *27*(4), 334-344. <https://doi.org/10.1108/08876041311330807>
- Gebauer, H., Gustafsson, A., & Witell, L. (2011). Competitive advantage through service differentiation by manufacturing companies. *Journal of Business Research*, *64*(12), 1270-1280. <https://doi.org/10.1016/j.jbusres.2011.01.015>
- Ghemawat, P. (1986). Sustainable advantage. *Harvard Business Review*, *64*, 53-58. <https://doi.org/10.1002/smj.1985>
- Gliem, R. R., & Gliem, J. A. (2003). Calculating,

- Interpreting, and Reporting Cronbach's Alpha Reliability Coefficient for Likert-type Scales. In *Midwest Research-to-Practice Conference in Adult, Continuing, and Community Education*.  
<https://doi.org/10.1109/PROC.1975.9792>
- Guo, X., Duff, A., & Hair, M. (2008). Service quality measurement in the Chinese corporate banking market. *International Journal of Bank Marketing*, 26(5), 305-327.  
<https://doi.org/10.1108/02652320810894389>
- Hafeez, K., Zhang, Y. B., & Malak, N. (2002). Determining key capabilities of a firm using analytic hierarchy process. *International Journal of Production Economics*, 76(1), 39-51  
[https://doi.org/10.1016/S0925-5273\(01\)00141-4](https://doi.org/10.1016/S0925-5273(01)00141-4)
- Hair, J. F., Celsi, M., Money, A., Samouel, P., & Page, M. (2015). *The essentials of business research methods: Third Edition. The Essentials of Business Research Methods: Third Edition*.  
<https://doi.org/10.4324/9781315716862>
- Hamel, G., & Prahalad, C. K. (1991). Corporate imagination and expeditionary marketing. *Harvard Business Review*. <https://doi.org/Article>
- Hitt, M. A., Hoskisson, R. E., & Ireland, R. D. (1990). Mergers and Acquisitions and Managerial Commitment to Innovation in M-Form Firms. *Strategic Management Journal*, 11, 29-47.
- Hitt, M. A., Ireland, R. D., & Hoskisson, R. E. (2013). *Strategic Management: Competitiveness and Globalization. IEEE Transactions on Information Theory*.  
<https://doi.org/10.1017/CBO9781107415324.004>
- Hsieh, Y. H., & Chen, H. M. (2011). Strategic fit among business competitive strategy, human resource strategy, and reward system. *Academy of Strategic Management Journal*, 10(2), 11-32.  
<https://doi.org/10.1016/j.matdes.2013.06.030>
- Humphrey, A. S. (2005). SWOT Analysis for Management Consulting. *SRI Alumni Association Newsletter*.
- Ireland, R. D., & Hitt, M. A. (2005). Achieving and maintaining strategic competitiveness in the 21st century: The role of strategic leadership. *Academy of Management Perspectives*, 19(4), 63-77.  
<https://doi.org/10.5465/ame.2005.19417908>
- Keep, W. W., & Nat, P. J. V. (2014). Multilevel marketing and pyramid schemes in the United States: An historical analysis. *Journal of Historical Research in Marketing*, 6(2), 188 - 210.  
<https://doi.org/10.1108/JHRM-01-2014-0002>
- Khandekar, A., & Sharma, A. (2005). Managing human resource capabilities for sustainable competitive advantage: An empirical analysis from Indian global organisations. *Education and Training*, 47(8/9), 628-639.  
<https://doi.org/10.1108/00400910510633161>
- Kurucz, E. C., Colbert, B. A., Lüdeke-Freund, F., Upward, A., & Willard, B. (2016). Relational leadership for strategic sustainability: Practices and capabilities to advance the design and assessment of sustainable business models. *Journal of Cleaner Production*, (Special Issue: Systematic Leadership Towards Sustainability), doi:10.1016/j.jclepro.2016.03.087
- Liu, Y. (2013). Sustainable competitive advantage in turbulent business environments. *International Journal of Production Research*, 51(10), 2821-2841  
<https://doi.org/10.1080/00207543.2012.720392>
- MacCallum, R. C., Browne, M. W., & Sugawara, H. M. (1996). Power analysis and determination of sample size for covariance structure modeling. *Psychological Methods*, 1(2), 130-149.  
<https://doi.org/10.1037/1082-989X.1.2.130>
- Melewar, T. C. (2003). Determinants of the corporate identity construct: A review of the literature. *Journal of Marketing Communications*, 9(4), 195-220.  
<https://doi.org/10.1080/1352726032000119161>
- Oppenheim, J., Bonini, S., Bielak, D., Kehm, T., & Lacy, P. (2007). *Shaping the New Rules of Competition : UN Global Compact Participant Mirror. Africa*.
- Peterson, R. A., & Kim, Y. (2013). On the relationship between coefficient alpha and composite reliability. *Journal of Applied Psychology*, 98(1), 194-198.  
<https://doi.org/10.1037/a0030767>
- Pfeffer, J. (1994). Competitive Advantage Through People. *California Management Review*, 36(2), 9-28.  
<https://doi.org/10.2307/41165742>
- Porter, M. E. (1979). Porter 1979 HBR How Competitive Forces Shape Strategy.pdf. *Harvard Business Review*.  
<https://doi.org/10.1016/j.jss.2016.05.042>
- Porter, M. E. (2008). The five competitive forces that shape strategy. *Harvard Business Review*. <https://doi.org/Article>
- Rackwitz, R. (2001). Reliability analysis-a review and some perspective. *Structural Safety*, 23(4), 365-395.  
[https://doi.org/10.1016/S0167-4730\(02\)00009-7](https://doi.org/10.1016/S0167-4730(02)00009-7)
- Ray, G., Barney, J. B., & Muhanna, W. A. (2004). Capabilities, business processes, and competitive advantage: Choosing the dependent variable in empirical tests of the resource-based view. *Strategic Management Journal*, 25(1), 23-37.  
<https://doi.org/10.1002/smj.366>
- Rowland, C., & Hall, R. (2014). Management learning, performance and reward: Theory and practice revisited. *Journal of Management Development*, 33(4), 342-356.  
<https://doi.org/10.1108/JMD-08-2012-0110>
- Srivastava, M., Franklin, A., & Martinette, L. (2013). Building a sustainable competitive advantage. *Journal of Technology Management and Innovation*, 8(2), 47-60.  
<https://doi.org/10.4067/S0718-27242013000200004>
- Strickland, T. Y. (2012). Planeación Estratégica En Las Empresas. *Revista de Historia Industrial*, XII(81), 4-19.
- Swarnalatha, C., & Prasanna, T. S. (2013). Leveraging employee engagement for competitive advantage: HR's strategic role. In *Proceedings of 3rd National Conference on Human Resource Management, NCHRM*

2013. <https://doi.org/10.1109/HICSS.2007.324>
- Trochim, W. M. . (2006). Types of Questions. *Research Methods Knowledge Base*.
- Urbancová, H. &, & Linhartová, L. (2011). Staff Turnover as a Possible Threat to Knowledge Loss. *Journal of Competitiveness*, 3, 84-98.
- Wernerfelt, B. (1984). The resource-based view of the firm. *Strategic Management Journal*, 5(2), 171-180. <https://doi.org/10.1002/smj.4250050207>
- Wernerfelt, B. (2013). Small forces and large firms: Foundations of the RBV. *Strategic Management Journal*, 34(6), 635-643. <https://doi.org/10.1002/smj.2043>
- Yelkur, R., & Herbig, P. (1996). Global markets and the new product development process. *Journal of Product & Brand Management*, 5(6), 38-47. <https://doi.org/10.1108/10610429610152822>
- Yukl, G. (2009). Leadership in Organizations. *Prentice Hall, the University of Michigan*
- WFDSA. (2011). Global direct selling - 2011 Retails Sales. Washington, DC, USA.