

# Agrobacterium-Mediated Co-transformation of Multiple Genes in *Metarhizium robertsii*

Israel Enrique Padilla-Guerrero<sup>1,\*</sup> and Michael J. Bidochka<sup>2</sup>

<sup>1</sup>Division of Natural and Exact Sciences, Department of Biology, University of Guanajuato, Campus Guanajuato, CP 36050, Guanajuato, Mexico

<sup>2</sup>Department of Biological Sciences, Brock University, St. Catharines, Ontario L2S 3A1, Canada

**Abstract** Fungi of the *Metarhizium* genus are a very versatile model for understanding pathogenicity in insects and their symbiotic relationship with plants. To establish a co-transformation system for the transformation of multiple *M. robertsii* genes using *Agrobacterium tumefaciens*, we evaluated whether the antibiotic nourseothricin has the same marker selection efficiency as phosphinothricin using separate vectors. Subsequently, in the two vectors containing the nourseothricin and phosphinothricin resistance cassettes were inserted eGFP and mCherry expression cassettes, respectively. These new vectors were then introduced independently into *A. tumefaciens* and used to transform *M. robertsii* either in independent events or in one single co-transformation event using an equimolar mixture of *A. tumefaciens* cultures. The number of transformants obtained by co-transformation was similar to that obtained by the individual transformation events. This method provides an additional strategy for the simultaneous insertion of multiple genes into *M. robertsii*.

**Keywords** *Agrobacterium*, Co-transformation, *Metarhizium*, Nourseothricin

Fungi of the *Metarhizium* genus are a versatile study model based on their biotechnological applications, which have been implemented for over 100 years [1]. Aside from insects, these fungi have been demonstrated to be safely compatible with other organisms (plants, animals, and humans) due to their entomopathogenic status. This specificity has allowed organisms from the *Metarhizium* genus to be approved by different environmental agencies, including the United States Environmental Protection Agency [2] and the Canada Pest Management Regulatory Agency [3], for marketing and extensive field use.

*Metarhizium* fungi are the most widely studied entomopathogens at both the molecular and biochemical level [1]. These organisms are globally distributed, and they

colonize a wide range of environments, including forests, savannas, marshes, coastal areas and deserts [1]. *M. robertsii* has become an excellent model organism for exploring several aspects of ecology and evolution, such as host specificity, changes, and specialization mechanisms [1, 4, 5]. In addition, *Metarhizium*-focused research is currently at the forefront of efforts to develop alternatives to chemical insecticides, such as biological control agents, for use in commercial agricultural products and disease vector control programs, and many of these agents are now on the market or in development [1, 6, 7].

Recently, the ecological impact of members of the *Metarhizium* genus and their potential as biological control agents has been reinforced by reports that *Metarhizium* fungi perform more environmental functions than previously believed. For example, *Metarhizium* fungi can interact with plants by colonizing their roots in a mycorrhizal and endophytic manner, establishing a symbiotic relationship with the plants, which stimulates their root growth [8], activates their defense system and increases their resistance to abiotic factors, such as salinity [9]. *Metarhizium* fungi also transfer nutrients, such as nitrogen, that are obtained from insect fungal parasites from the soil to the plant roots [10]. In turn, plants transfer carbon compounds to the fungi [11], indicating that *Metarhizium* fungi and plants have a mutualistic symbiotic relationship [11].

The numerous, diverse interactions between *Metarhizium* fungi and the environment has supported genomic sequencing of the species *M. robertsii*, *M. acridum*, *M. rileyi*,

Mycobiology 2017 June, 45(2): 84-89  
<https://doi.org/10.5941/MYCO.2017.45.2.84>  
pISSN 1229-8093 • eISSN 2092-9323  
© The Korean Society of Mycology

**\*Corresponding author**

E-mail: ie.padillaguerrero@ugto.mx

**Received** May 10, 2017

**Revised** May 19, 2017

**Accepted** June 11, 2017

©This is an Open Access article distributed under the terms of the Creative Commons Attribution Non-Commercial License (<http://creativecommons.org/licenses/by-nc/3.0/>) which permits unrestricted non-commercial use, distribution, and reproduction in any medium, provided the original work is properly cited.

*M. majus*, *M. brunneum*, *M. guizhouense*, *M. anisopliae*, and *M. album* [12-16]. Molecular tools have been adapted to further elucidate the characteristics and differences of each of these *Metarhizium* species. For example, the use of exogenous selection markers have been successfully identified, such as benomyl [17], phosphinothricin [18], geneticin [19], chlorimuron ethyl [20] and recently, nourseothricin [21]. Thus far, *Agrobacterium*-mediated transformation is the most efficient and successfully applied technique in *Metarhizium* for exogenous DNA insertion and gene inactivation [22]. In this work, we evaluate the efficiency of the antibiotic nourseothricin as a selection marker, finding that its performance is equal to that of the herbicide phosphinothricin, which is the most selection marker used in *Metarhizium* fungi. Both nourseothricin and phosphinothricin were used to perform co-transformation mediated by *Agrobacterium tumefaciens*, which has not been reported in fungi, showing high efficiency in *M. robertsii* by simultaneously inserting multiple genes in separate vectors in a single event.

## MATERIALS AND METHODS

**Fungal and bacterial strains.** The *M. robertsii* strain ARSEF 2575 was obtained from the United States Department of Agriculture Collection of Entomopathogenic Fungal Cultures (Ithaca, NY, USA). Cultures were grown on potato dextrose agar at 27°C for 10 days for conidia harvest. *Escherichia coli* XL-Blue competent cells were used for vector construction using standard molecular techniques [23]. *A. tumefaciens* AGL1 was used as the carrier for the individually constructed vectors for fungal transformation as previously described [24].

**Binary vector construction.** The pPK2-BAR vector was constructed by inserting a PtrpC-BAR *XbaI/EcoRI* fragment from pBARKS1-*SpeI* previously cut and self-ligating at the *SpeI* sites from pBARKS1 [25] into the *XbaI/EcoRI* sites in binary pPK2 vector [26]. The pPK2-BAR-mCherry vector was constructed by amplifying the TtrpC fragment with the primers TtrpC-*XbaI*-Up (5'-TCTCTAGAAAAGAAGG-ATTACCTCTAAACA-3') and TtrpC-*SpeI*-*BamHI*-Down (5'-GAGGATCCAGCAGACTAGTCACTTAACGTTACT-GAAATCA-3') from the pBARGEM7-2 vector [25] and then inserting the amplified fragment into the *SpeI/BamHI* sites in pPK2-BAR. The Pgpda-mCherry fragment was subsequently released from the pGG464 vector [27] and cloned into the *EcoRI/BamHI* sites. The pPK2-NTC vector was constructed by amplifying the nourseothricin-resistance cassette with the primers PNAT-*XbaI* (5'-TATCTAGAGC-GGAGAGACGGA-3') and 5NAT-*BglII* (5'-ATAGATCTT-TAGGGCAGGGCATG-3') using the pA-NTC-OSCAR vector as a template [28] and then inserting the amplified fragment into the pPK2-BAR binary vector using the *XbaI/BglII* sites. The pPK2-NTC-eGFP vector was constructed by amplifying the GFP cassette with the primers 5CST-

EGFP (5'-ATGAATTCGGGTAGCAAACGGTGGTCAAAG-3') and 3CST-EGFP (5'-ATAGATCTCTGTCTGGTCTT-CTACACGAAGGAA-3') from the pFBENGFP vector [24] and then inserting the amplified fragments into the *EcoRI/BglII* sites in the pPK2-NTC plasmid. The T-DNA vector sequences of pPK2-BAR, pPK2-NTC, pPK2-NTC-eGFP, and pPK2-BAR-mCherry were deposited into the NCBI GenBank database under the accession numbers MF169981, MF169982, MF169983, and MF169984, respectively.

**Fungal transformation.** The four vectors generated were introduced individually into *A. tumefaciens* strain AGL1 cells. For the *Metarhizium* agro-transformation, we followed the protocol previously described by Fang and collaborators [24] with some modifications. Briefly,  $1 \times 10^6$  conidia suspended in 0.01% Triton X-100 were placed in a 1.5-mL Eppendorf tube and centrifuged for 5 min at 4,000  $\times$ g. The Triton X-100 solution was removed to preserve the conidia buttons, and the buttons were then mixed with 1 mL of *A. tumefaciens* cells, induced ( $OD_{660} = 0.7-0.8$ ) and vortexed for 30 sec. Next, 200  $\mu$ L of the mixture was spread on black filter paper to continue the protocol described by Fang *et al.* [24]. Nourseothricin (Gold Biotechnology, St. Louis, MO, USA) and phosphinothricin (herbicide Finale; Bayer Crop Science AG, Leverkusen, Germany) were used at concentrations of 350  $\mu$ g/mL and 250  $\mu$ g/mL, respectively, for individual selection on M-100 agar medium [24].

For co-transformation of *M. robertsii* mediated by *A. tumefaciens*, separate *A. tumefaciens* cultures containing the pPK2-NTC-eGFP and pPK2-BAR-mCherry vectors were induced with acetosyringone as described [24]. After the cells were induced ( $OD_{660} = 0.7-0.8$ ), they were mixed equimolarly in a 1:1 ratio with *M. robertsii* conidia to continue the protocol described above. For double selection of the transformants, 350  $\mu$ g/mL nourseothricin and 250  $\mu$ g/mL phosphinothricin were simultaneously added on M-100 agar medium.

**Transformant verification.** The obtained transformants were verified by three passes on their respective plates containing the antibiotics. DNA extraction was then performed by grinding frozen mycelia and adding phenol-chloroform [23]. Next, 100 ng of the extracted DNA was used as a template to verify the transformants using PCR to detect the presence of the corresponding resistance and fluorescence cassettes. The nourseothricin-resistance cassette was amplified using the oligonucleotides PNAT-*XbaI* and 5NAT-*BglII*, the eGFP cassette was amplified using the oligonucleotides 5CST-EGFP and 3CST-EGFP, the phosphinothricin-resistance cassette was amplified using the oligonucleotides PtrpC-*XbaI* (5'-ATTCTAGAATCGA-CAGAAGATGATATTGAAGGA-3') and Bar-down (5'-TCAGATCTCGGTGACGGGC-3'), and the mCherry cassette was amplified using the oligonucleotides Pgpda-short (5'-GCCGAGAGACGGACGGAC-3') and cherry-down (5'-TTACTTGTACAGCTCGTCCATGCC-3'). Protein expression

of the fluorescent reporter protein was confirmed by visual inspection using a Nikon OPTIPHOT-2 microscope (Nikon, Tokyo, Japan) equipped with epifluorescent illumination.

## RESULTS AND DISCUSSION

Co-transformation is defined as the simultaneous introduction of multiples genes in a cell, and the genes can be present on the same plasmid or on separate plasmids [29]. The main advantage of co-transformation for the transfer of multiples genes is that a single transformation event can result in the integration of multiples transgenes as opposed

to sequential transformation, which requires multiple time-consuming transformation events [29]. Co-transformation can be adapted to a variety of transformation methods, such as electroporated, biolistic, protoplasts and *Agrobacterium*-mediated transformation [29-31]. Several different strategies have been employed in *Agrobacterium*-mediated co-transformation for the independent delivery of T-DNA in plants [31], but *Agrobacterium*-mediated co-transformation in fungi has not yet been reported. T-DNA can be held in mixed bacterial strains in which two T-DNA molecules are contained in separate binary vectors in different *Agrobacterium* cells or in a single bacterial strain, whereby

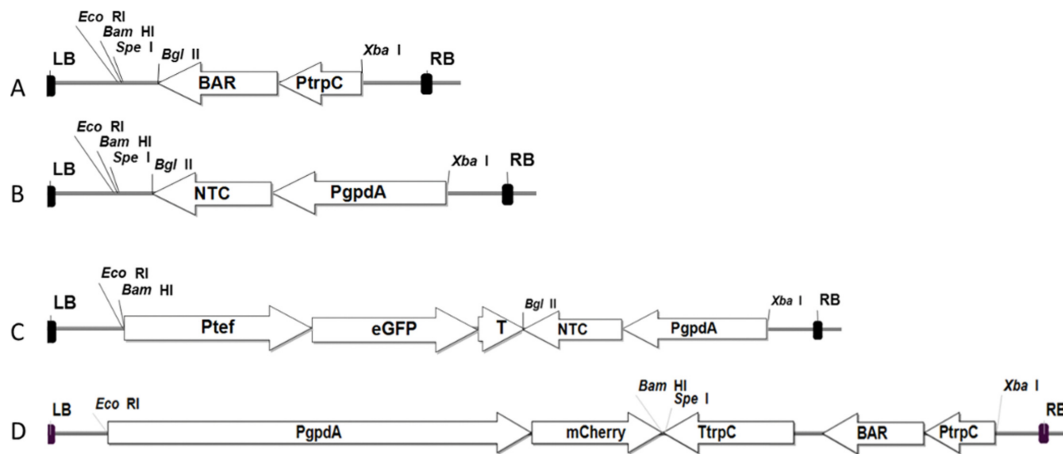

**Fig. 1.** T-DNA vector construction. A, T-DNA in the pPK2-NTC vector for nourseothricin selection; B, T-DNA in the pPK2-BAR vector for phosphinothricin selection; C, T-DNA in the pPK2-NTC-eGFP vector for nourseothricin resistance using green fluorescence for visual selection; D, T-DNA in the pPK2-BAR-mCherry vector with phosphinothricin resistance using cherry fluorescence for visual selection. PgpdA, promoter of glyceraldehyde-3-phosphate dehydrogenase gene from *Aspergillus nidulans*; NTC, nourseothricin resistance *nat1* gene from *Filobasidiella neoformans*; Ptef, promoter of translation elongation factor gene from *Aureobasidium pullulans*; eGFP, enhanced green fluorescent protein gene; T, termination region of the glucoamylase gene from *Aspergillus awamori*; PtrpC, promoter of *tryptophan C* gene from *Aspergillus nidulans*; BAR, phosphinothricin resistance gene from *Streptomyces hygroscopicus*; TtrpC, terminator of *tryptophan C* gene from *Aspergillus nidulans*; mCherry, cherry fluorescent protein gene; RB and LB are the right and left border of T-DNA, respectively.

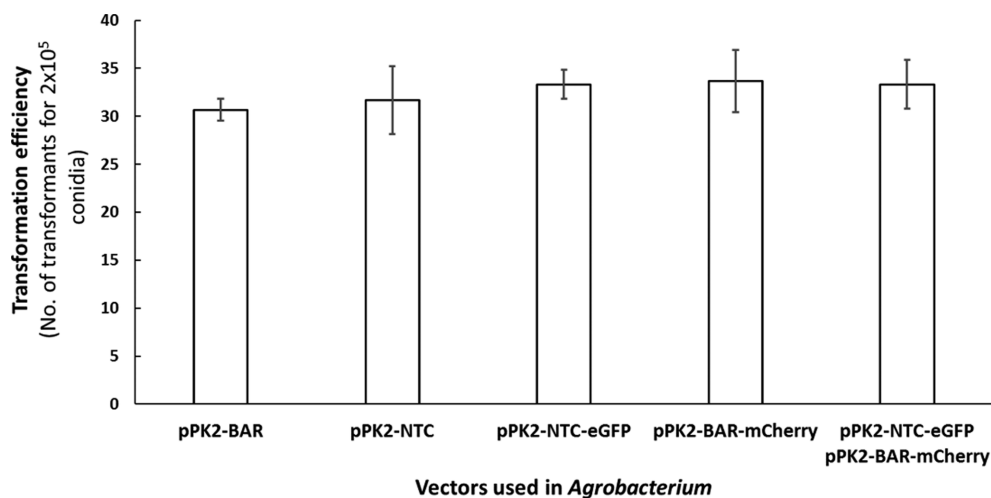
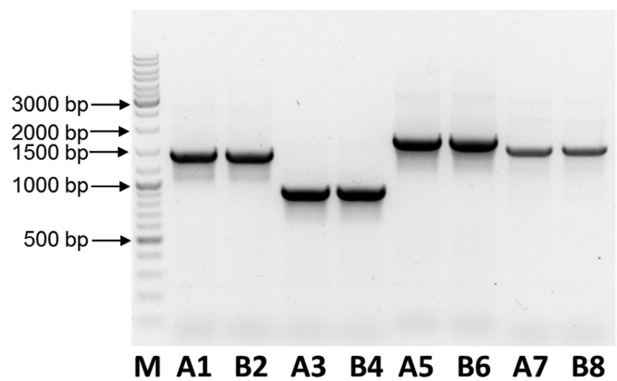

**Fig. 2.** The transformation and co-transformation efficiency in *Metarhizium robertsii* using the vectors generated in this work. Each transformation was performed three times, and the transformants were counted. The bars represent the standard error.

two T-DNA molecules could either be held in distinct regions on the same binary plasmid or on separate binary plasmids [31].

In this study, we used a mixed approach involving *Agrobacterium* containing two different T-DNA molecules on separate binary vectors to evaluate co-transformation mediated by *Agrobacterium* in *M. robertsii*. To identify a selection marker with the same efficiency as phosphinothricin for use in co-transformation, we evaluated the efficiency of the antibiotic nourseothricin, which has been used to transform *M. robertsii*, but its efficiency in this fungus has not been analyzed [21]. This antibiotic inhibits protein synthesis by inducing miscoding [32], and resistance is conferred by the nourseothricin acetyltransferase 1 (*nat1*) gene from *Streptomyces noursei* [32]. We determined that the concentration of nourseothricin required to inhibit *M. robertsii* growth on agar medium M-100 at 28°C is 350 µg/mL. The plates were incubated for 20 days without observing spontaneous mutant resistance. Once the efficiency of nourseothricin in *M. robertsii* on M-100 agar medium was established, the binary vectors pPK2-NTC (Fig. 1A), pPK2-NTC-eGFP (Fig. 1B), pPK2-BAR (Fig. 1C), and pPK2-BAR-mCherry (Fig. 1D) were constructed as described in the materials and methods section.

There was no difference in the number of transformants obtained using either nourseothricin or phosphinothricin as the selection agent in the *Agrobacterium*-mediated transformation experiments (Fig. 2), demonstrating that nourseothricin as well as phosphinothricin can be used as a dominant selection marker in *Metarhizium*.



**Fig. 3.** Transformant confirmation analysis by PCR. The amplicons of two transformants (A, B) obtained by *Agrobacterium*-mediated co-transformation with the vectors pPK2-NTC-eGFP and pPK2-BAR-mCherry are shown. Lane M, DNA molecular size marker; lane A1–B2, NTC cassette, 1,435 bp; lane A3–B4, BAR cassette, 938 bp; lane A5–B6, GFP cassette, 1,736 bp; lane A7–B8, mCherry cassette, 1,561 bp.

These results lead us to perform an *Agrobacterium*-mediated co-transformation using both nourseothricin and phosphinothricin simultaneously to avoid pleiotropic effects. We co-transformed *Metarhizium* using the vectors pPK2-NTC-eGFP and pPK2-BAR-mCherry, and the number of resulting transformants was similar to that resulting from the individual transformation experiments in which the individual vectors were used. The high transformation efficiency using *Agrobacterium*-mediated co-transformation

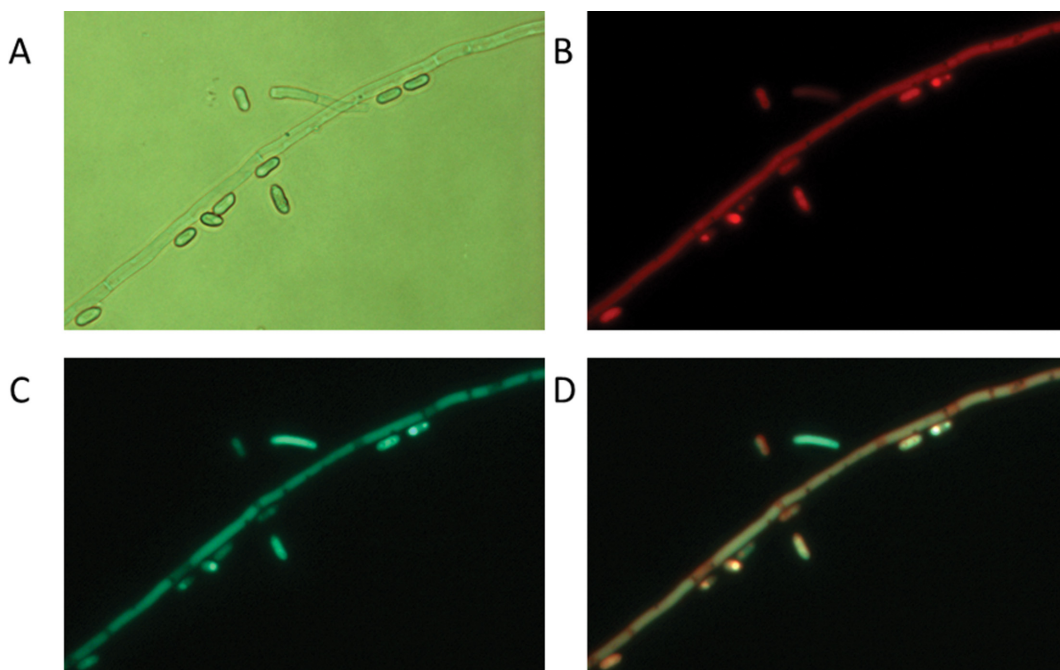

**Fig. 4.** Verification of *Agrobacterium*-mediated co-transformation using visual markers. The strain co-transformed with pPK2-NTC-eGFP and pPK2-BAR-mCherry vectors shows fluorescence in hyphae and conidia. A, Bright field image; B, Cherry fluorescence image; C, Green fluorescence image; D, Merge of the cherry (B) and green (C) images (A–D, ×400).

in *M. robertsii* suggests a synergistic effect. This transformation efficiency is consistent with co-transformation in plants, as a larger number of genes involved in the co-transformation reportedly increases the efficiency of the transformants obtained when *Agrobacterium* is used [31]. Transgene integration was confirmed by PCR (Fig. 3) and fluorescence microscopy (Fig. 4).

In this study, for the first time in fungi, we reported the use of *Agrobacterium*-mediated co-transformation to integrate multiple genes into the *M. robertsii* genome using mixed *Agrobacterium* cells containing two different T-DNA molecules on separate binary vectors, thus improving the genetic strategies for studying this fungus. The advantages of this co-transformation method can facilitate the study of *Metarhizium* by reducing valuable time spent on constructing complex or long T-DNA molecules in binary vectors and sequential transformations.

## ACKNOWLEDGEMENTS

We gratefully received financial support from the following institutions: Universidad de Guanajuato (CIFOEA 89/2016), and Secretaría de Educación Pública (PROMEP UGTO-PTC-327).

## REFERENCES

1. Roberts DW, St Leger RJ. *Metarhizium* spp., cosmopolitan insect-pathogenic fungi: mycological aspects. *Adv Appl Microbiol* 2004;54:1-70.
2. Fang W, Vega-Rodríguez J, Ghosh AK, Jacobs-Lorena M, Kang A, St Leger RJ. Development of transgenic fungi that kill human malaria parasites in mosquitoes. *Science* 2011;331:1074-7.
3. Health Canada's Consumer Product Safety. Proposed Registration Decision for *Metarhizium anisopliae* strain F52 [Internet]. Hamilton (ON): Health Canada's Consumer Product Safety; 2011 [cited 2011 Oct 27]. Available from: [http://www.hc-sc.gc.ca/cps-spc/pest/part/consultations/\\_prd2011-13/prd2011-13-eng.php#a1](http://www.hc-sc.gc.ca/cps-spc/pest/part/consultations/_prd2011-13/prd2011-13-eng.php#a1).
4. Wang S, Leclercq A, Pava-Ripoll M, Fang W, St Leger RJ. Comparative genomics using microarrays reveals divergence and loss of virulence-associated genes in host-specific strains of the insect pathogen *Metarhizium anisopliae*. *Eukaryot Cell* 2009;8:888-98.
5. Wang S, Fang W, Wang C, St Leger RJ. Insertion of an esterase gene into a specific locust pathogen (*Metarhizium acridum*) enables it to infect caterpillars. *PLoS Pathog* 2011;7:e1002097.
6. Lomer CJ, Bateman RP, Johnson DL, Langewald J, Thomas M. Biological control of locusts and grasshoppers. *Annu Rev Entomol* 2001;46:667-702.
7. St Leger RJ, Wang C. Genetic engineering of fungal biocontrol agents to achieve greater efficacy against insect pests. *Appl Microbiol Biotechnol* 2010;85:901-7.
8. Sasan RK, Bidochka MJ. The insect-pathogenic fungus *Metarhizium robertsii* (Clavicipitaceae) is also an endophyte that stimulates plant root development. *Am J Bot* 2012;99:101-7.
9. Khan AL, Hamayun M, Khan SA, Kang SM, Shinwari ZK, Kamran M, Ur Rehman S, Kim JG, Lee IJ. Pure culture of *Metarhizium anisopliae* LHL07 reprograms soybean to higher growth and mitigates salt stress. *World J Microbiol Biotechnol* 2012;28:1483-94.
10. Behie SW, Zelisko PM, Bidochka MJ. Endophytic insect-parasitic fungi translocate nitrogen directly from insects to plants. *Science* 2012;336:1576-7.
11. Behie SW, Moreira CC, Sementchoukova I, Barelli L, Zelisko PM, Bidochka MJ. Carbon translocation from a plant to an insect-pathogenic endophytic fungus. *Nat Commun* 2017;8:14245.
12. Gao Q, Jin K, Ying SH, Zhang Y, Xiao G, Shang Y, Duan Z, Hu X, Xie XQ, Zhou G, et al. Genome sequencing and comparative transcriptomics of the model entomopathogenic fungi *Metarhizium anisopliae* and *M. acridum*. *PLoS Genet* 2011;7:e1001264.
13. Hu X, Xiao G, Zheng P, Shang Y, Su Y, Zhang X, Liu X, Zhan S, St Leger RJ, Wang C. Trajectory and genomic determinants of fungal-pathogen speciation and host adaptation. *Proc Natl Acad Sci U S A* 2014;111:16796-801.
14. Pattemore JA, Hane JK, Williams AH, Wilson BA, Stodart BJ, Ash GJ. The genome sequence of the biocontrol fungus *Metarhizium anisopliae* and comparative genomics of *Metarhizium* species. *BMC Genomics* 2014;15:660.
15. Staats CC, Junges A, Guedes RL, Thompson CE, de Morais GL, Boldo JT, de Almeida LG, Andreis FC, Gerber AL, Sbaraini N, et al. Comparative genome analysis of entomopathogenic fungi reveals a complex set of secreted proteins. *BMC Genomics* 2014;15:822.
16. Shang Y, Xiao G, Zheng P, Cen K, Zhan S, Wang C. Divergent and convergent evolution of fungal pathogenicity. *Genome Biol Evol* 2016;8:1374-87.
17. Bernier L, Cooper RM, Charnley AK, Clarkson JM. Transformation of the entomopathogenic fungus *Metarhizium anisopliae* to benomyl resistance. *FEMS Microbiol Lett* 1989;60:261-5.
18. Fang W, Pei Y, Bidochka MJ. A regulator of a G protein signalling (RGS) gene, *cag8*, from the insect-pathogenic fungus *Metarhizium anisopliae* is involved in conidiation, virulence and hydrophobin synthesis. *Microbiology* 2007;153(Pt 4):1017-25.
19. Sevim A, Donzelli BG, Wu D, Demirbag Z, Gibson DM, Turgeon BG. Hydrophobin genes of the entomopathogenic fungus, *Metarhizium brunneum*, are differentially expressed and corresponding mutants are decreased in virulence. *Curr Genet* 2012;58:79-92.
20. Lin L, Wang F, Wei D. Chlorimuron ethyl as a new selectable marker for disrupting genes in the insect-pathogenic fungus *Metarhizium robertsii*. *J Microbiol Methods* 2011;87:241-3.
21. Cook D, Donzelli BG, Creamer R, Baucom DL, Gardner DR, Pan J, Moore N, Krasnoff SB, Jaromczyk JW, Scharld CL. Swainsonine biosynthesis genes in diverse symbiotic and pathogenic fungi. *G3 (Bethesda)* 2017;7:1791-7.
22. Xu C, Zhang X, Qian Y, Chen X, Liu R, Zeng G, Zhao H, Fang W. A high-throughput gene disruption methodology for

- the entomopathogenic fungus *Metarhizium robertsii*. PLoS One 2014;9:e107657.
23. Sambrook J, Russell DW. Molecular cloning: a laboratory manual. 3rd ed. Cold Spring Harbor (NY): Cold Spring Harbor Laboratory Press; 2001.
  24. Fang W, Pei Y, Bidochka MJ. Transformation of *Metarhizium anisopliae* mediated by *Agrobacterium tumefaciens*. Can J Microbiol 2006;52:623-6.
  25. Pall ML, Brunelli JP. A series of six compact fungal transformation vectors containing polylinkers with multiple unique restriction sites. Fungal Genet Rep 1993;40:59-62.
  26. Covert SF, Kapoor P, Lee MH, Briley A, Nairn CJ. *Agrobacterium tumefaciens*-mediated transformation of *Fusarium circinatum*. Mycol Res 2001;105:259-64.
  27. Padilla-Guerrero IE, Barelli L, González-Hernández GA, Torres-Guzmán JC, Bidochka MJ. Flexible metabolism in *Metarhizium anisopliae* and *Beauveria bassiana*: role of the glyoxylate cycle during insect pathogenesis. Microbiology 2011;157:199-208.
  28. Paz Z, García-Pedrajas MD, Andrews DL, Klosterman SJ, Baeza-Montañez L, Gold SE. One step construction of *Agrobacterium*-recombination-ready-plasmids (OSCAR), an efficient and robust tool for ATMT based gene deletion construction in fungi. Fungal Genet Biol 2011;48:677-84.
  29. Xu Y. Gene transfer and genetically modified plants. In: Xu Y, editor. Molecular plant breeding. Bodmin: MPG Books Group; 2010. p. 479-500.
  30. St. Leger RJ, Shimizu S, Joshi L, Bidochka MJ, Roberts DW. Co-transformation of *Metarhizium anisopliae* by electroporation or using the gene gun to produce stable GUS transformants. FEMS Microbiol Lett 1995;131:289-94.
  31. Li FF, Wu SJ, Chen TZ, Zhang J, Wang HH, Guo WZ, Zhang TZ. *Agrobacterium*-mediated co-transformation of multiple genes in upland cotton. Plant Cell Tissue Organ Cult 2009;97: 225-35.
  32. McDade HC, Cox GM. A new dominant selectable marker for use in *Cryptococcus neoformans*. Med Mycol 2001;39:151-4.