

Characteristic Analysis of Planetary Gear Set of Hydromechanical Transmission System of Agricultural Tractors

Young-Jun Park^{1*}, Jeong-Gil Kim², Geun-Ho Lee¹

¹Department of System Reliability, Korea Institute of Machinery and Materials, Daejeon, Korea

²Convergence Components & Agricultural Machinery Group, Korea Institute of Industrial Technology, Gimje, Korea

Received: June 29th, 2016; Revised: July 27th, 2016; Accepted: August 8th, 2016

Abstract

Purpose: This study aims to establish the effect of pinhole position errors in the planet carrier of a planetary gear set (PGS) on load sharing among the planet gears in the hydromechanical transmission (HMT) system of an agricultural tractor. **Methods:** A simulation model of a PGS with five planet gears was developed to analyze load sharing among the planet gears. The simulation model was verified by comparing its results with those of a model developed in a previous study. The verified simulation model was used to analyze the load-sharing characteristics of the planet gears with respect to the pinhole position error and the input torque to the PGS. **Results:** Both simulation models had identical load magnitude sequences for the five planet gears. However, the load magnitudes on the corresponding planet gears differed between the models because of the different stiffnesses of the PGS components and the input torques to the PGS. The verified simulation model demonstrated that the evenness of load sharing among the planet gears increases with decreasing pinhole position error and increasing input torque. **Conclusions:** The geometrical tolerance of the pinhole position should be properly considered during the design of the planet carrier to improve the service life of the PGS and load sharing among the planet gears.

Keywords: Agricultural tractor, Hydromechanical transmission, Load sharing, Pinhole position error, Planet carrier, Planetary gear set

Introduction

Tractors are multipurpose machines used to perform various functions such as pulling and driving different types of agricultural equipment (e.g., mowers, loaders, balers, plows, and rotaries). The transmission that transfers power from the engine to the attached equipment is an important part of a tractor (Goering et al., 2003). Continuously variable transmissions (CVTs) were introduced with the recent increase in the size of agricultural tractors to improve fuel and work efficiency, operation convenience, and riding comfort. A CVT usually comprises a hydro-mechanical transmission (HMT) system, which has a

hydrostatic unit (HSU) serving as a variator, and a planetary gear set (PGS).

The load applied to the PGS of a HMT system in a tractor must be evenly shared among the planet gears to increase the mechanical efficiency and durability of the system. The load-sharing factor is 1 when the load magnitudes borne by all the planet gears are equal. However, the load sharing may be uneven because of errors in the manufacture of the gears and the planet carrier or in the transmission system assembly. In such cases, the load-sharing factor will be greater than 1, and the service life of the PGS may be shortened (American Gear Manufacturers Association, 2006; International Organization for Standardization, 2003-2007).

Kahraman and Vijayakar (2001) developed a simulation model of planet gears to investigate the effect of the

*Corresponding author: Young-Jun Park

Tel: +82-42-868-7994; Fax: +82-42-868-7477

E-mail: yjpark77@kimm.re.kr

flexibility of ring gears' on load sharing. The authors found that the evenness of load sharing increased with increasing flexibility (Kahraman and Vijayakar, 2001). Bodas and Kahraman (2004) also used a simulation model to show that load sharing in a given planetary gear set varied with the gear assembly position (Bodas and Kahraman, 2004). Singh (2005) used a simulation model to analyze the effect of load sharing with respect to the pinhole position error in the carrier and the number of planet gears (Singh, 2005). Moreover, Prueter et al. (2011) examined load sharing by attaching strain gauges to the tooth root of a ring gear in a PGS used in a wind turbine gearbox and verified the observations by using a commercial software. Park et al. (2013) used a simulation model of a 2 MW wind turbine gearbox to analyze the effects of non-torque loading on load sharing among the planet gears and the load distribution over the gear tooth flank in a PGS; the results were then used to predict the service life of the PGS.

The simple simulation models in the previous studies were developed by either considering only a PGS or linearizing the whole system, which causes inaccuracies in the analysis results. Simultaneous modeling and analysis of the whole system through a system level analysis are very important for accurately predicting the load sharing of a PGS. These steps are significant because gear mesh misalignment, which is the basis for estimating load sharing, depends on shaft deflection, bearing deformation, and flexibility of the housing, planet carriers, and ring gears. Therefore, an exact prediction of load sharing by a component level analysis may not be easy. The developed simulation model can predict load sharing more accurately owing to the advantage that the HMT system is modeled as a whole.

The present study aimed to analyze the effects of pinhole position errors in the planet carrier of the PGS of a HMT system in a tractor on load sharing among the planet gears. The load-sharing characteristics of the PGS were investigated using a commercial software (Romax Technology Ltd., 2003) to develop a simulation model. The model was verified by comparing its results with those of a model developed in a previous study (Singh, 2005). The verified simulation model was used to investigate the load-sharing characteristics of the PGS with respect to the magnitude of the pinhole position error in the carrier and the input torque to the PGS.

Materials and Methods

Structure of the PGS of a HMT system in a tractor

Figure 1(a) shows the HMT system considered in this study. The HMT system consists of a main shift comprising a PGS, an HSU, a gear train, a four-speed subshift, and a forward/reverse shift. The PGS in the mechanical transmission part comprises a compound PGS and a Wolfram PGS. The compound PGS is operated when the main shift output is the carrier (C), whereas the Wolfram PGS is operated when the output is a Stage 2 sun gear (S2) of the PGS. The PGS splits the engine power into the HSU and the subshift. The HSU in the hydraulic transmission part works as a variator that enables the HMT system for a continuous variable shift. The six clutches installed in the subshift and the forward and reverse shift are divided as follows depending on their functions: directional clutches (i.e., KF and KR), which determine the rotating direction of the output shafts; and mode clutches (i.e., K1, K2, K3, and K4), which control the subshift mode. The directional and mode clutches, which form a total of two clutches, must be connected to transmit the input power to the output shaft.

Figure 1(b) shows the simulation model of the HMT system, and Figure 2 presents the PGS configuration. Table 1 lists the PGS specifications. The PGS consists of a sun gear, five planet gears, a ring gear, and a planet carrier. The power is input to the sun and ring gears and transmitted to the carrier when the HMT system works in the power-split mode. The power is input to the sun gear and transmitted to the ring gears and the carrier in the power-circulation mode (Sung et al., 2001).

Pinhole position error in the planet carrier

The pinhole position error of a carrier is caused by shortcomings in the machining precision and accuracy of the manufacturing equipment and various carrier deformations during machining. Accordingly, variables identical to those used in Singh's (2005) study were employed to verify the developed simulation model. The position error at carrier pinhole #2 was set as 0, 50, and $-50 \mu\text{m}$. Load sharing among the planet gears of the PGS under these conditions was analyzed.

The input torque from the HMT system was subsequently varied within the range 25%-200% of the rated torque in increments of 25%. The pinhole position error in the carrier

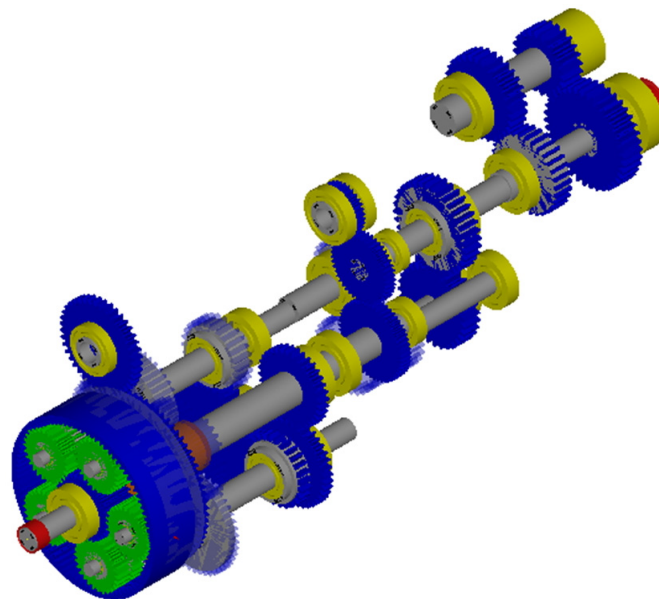
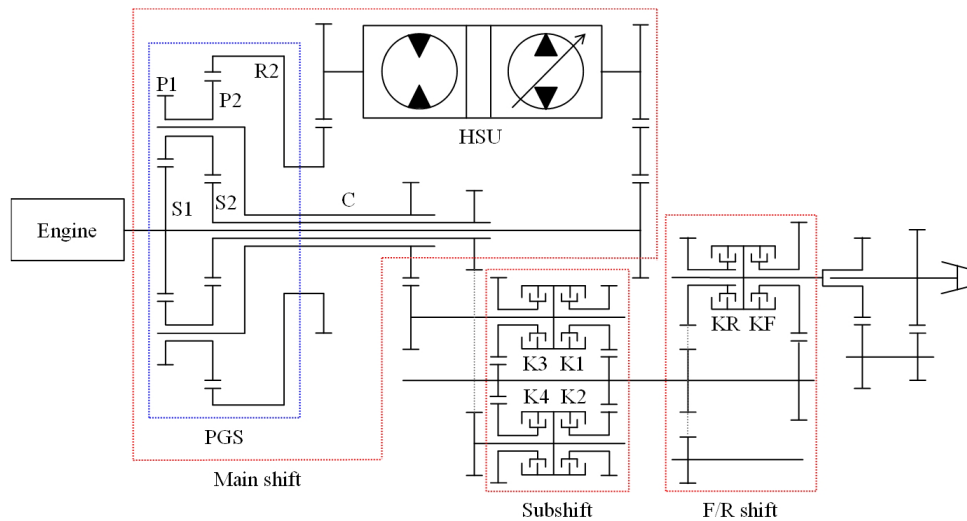

Figure 1. Simulation model of a HMT system in a tractor.

was set as 80, 40, -40, and 0 μm . The input torque ranged from 25% to 200% because the PGS in the HMT system was designed to transmit up to 200% of the rated torque. Meanwhile, the pinhole position errors were determined as 80, 40, -40, and 0 μm because the maximum geometric tolerance of the pinhole position in a carrier drawing was 80 μm . The load-sharing characteristics of the planet gears under different conditions were also analyzed using the verified simulation model. The pinhole position error in the carrier was varied in increments of 25 μm within the range 0-100 μm . The resulting in the load-sharing factor was also observed. Figure 3 shows the pinhole position error in the carrier. The blue and red arrows indicate the

directions of the positive and negative errors, respectively.

Load-sharing factor of the PGS

The load-sharing factor is a measure of the unevenness in the load distribution among the planet gears for multiple transmission paths. This factor is defined by Eq. (1) as follows (American Gear Manufacturers Association, 2006):

$$K_\gamma = \frac{T_{Branch} N_{CP}}{T_{Nom}} \quad (1)$$

where

N_{CP} : number of planets;
 T_{Branch} : torque in the branch with the heaviest load; and
 T_{Nom} : total nominal torque.

Load sharing among the planet gears is influenced by

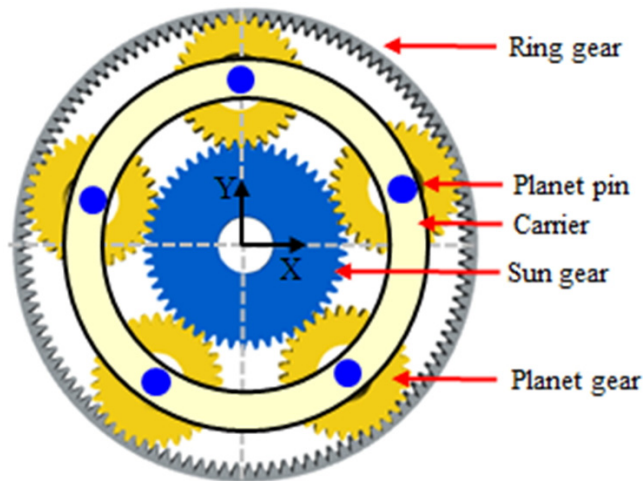

Figure 2. PGS configuration.

Table 1. PGS specifications

| Item | Sun gear | Planet gear | Ring gear |
|---------------------------|----------|-------------|-----------|
| Module, mm | | 3.5 | |
| Number of teeth | 50 | 31 | -115 |
| Pressure angle, ° | | 20 | |
| Center distance, mm | | 142.8 | |
| Pitch circle diameter, mm | 176.2 | 109.3 | -390.9 |
| Face width, mm | 74 | 72 | 74 |

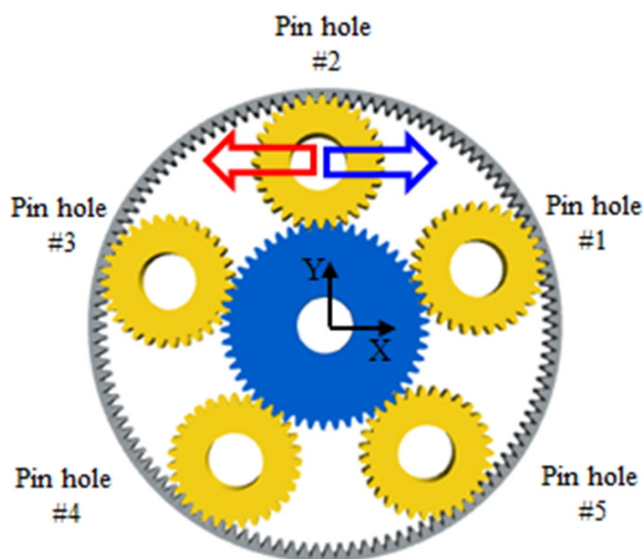

Figure 3. Pinhole position errors in the planet carrier.

many factors, including the external load on the gears, tangential velocity, and manufacturing accuracy. As mentioned earlier, the load-sharing factor is either equal to or greater than 1, depending on whether or not the planet gears equally share the load.

Results and Discussion

Simulation model verification

Load sharing among the planet gears in the present and previously developed (Singh, 2005) PGS simulation models were compared with regard to pinhole position errors of 0, -50, and 50 μm . The simulation cases are identified as A (0 μm), A (50 μm), and A (-50 μm) for the present model and as B (0 μm), B (50 μm), and B (-50 μm) for the previous model (Figure 4). A (0 μm) and B (0 μm) are cases without any pinhole position error. The load-sharing factors of the planet gears in A (0 μm) were 0.987, 0.999, 1.013, 1.009, and 0.992, whereas those in B (0 μm) were all approximately 1. However, the graphical representation of the results made determination of the exact values difficult. The analysis results for A (0 μm) and B (0 μm) were very similar. The small differences could only be attributed to changes in the gravitational characteristics of the gear mesh with respect to the positions of the planet gears.

The load-sharing factors for A (50 μm) were 0.114, 2.081, 0.138, 1.344, and 1.323, and those for B (50 μm) were 0.748, 1.337, 0.722, 1.085, and 1.107. These two cases produced the largest loads on planet gear #2. The second largest loads in these cases were borne by planet gears #4 and #5, which were located at 144° from planet gear #2 in the clockwise and counter-clockwise directions, respectively. The smallest loads were borne by planet gears #1 and #3, which were immediately adjacent to planet gear #2.

The load-sharing factors of the planet gears in A (-50 μm) were 1.791, 0.003, 1.818, 0.702, and 0.686, and those in B (-50 μm) were 1.267, 0.684, 1.250, 1.114, and 1.087. The largest loads in these two cases were borne by planet gears #1 and #3, followed by #4 and #5. The smallest load was borne by mispositioned planet gear #2.

The sequences of load magnitudes on the planet gears in the present and previous simulation models were identical in the cases of 50 and -50 μm pinhole position errors (Singh, 2005). However, the actual load magnitudes

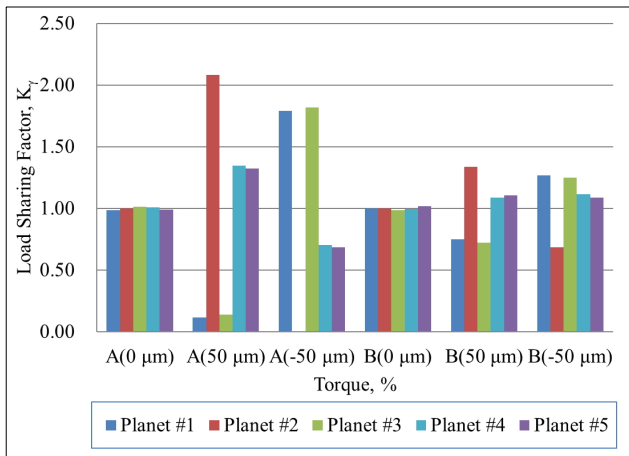

Figure 4. Comparison of the load-sharing factors in the present and previous simulation models.

differed because of the differing input torques and stiffnesses of the PGS components, including the gear, bearing, carrier, and planet pins. The stiffnesses and input torque could not be duplicated in the two models. Hence, the load-sharing factors of the corresponding gears differed. However, the similar sequences of the load magnitudes borne by the planet gears indicate that the present simulation model can be used to predict the load-sharing characteristics in a PGS.

Analysis of load sharing with respect to pinhole position errors and input torque

A commercial software (Romax Technology Ltd., 2003) was used to analyze load sharing among the planet gears of the PGS with respect to the pinhole position error and input torque. In the analysis, the input torque from the HMT system was increased within the range of 25%-200% of the rated torque in increments of 25% and the position error of pinhole #2 was set as 80, 40, -40, and 0 μm -identified as cases 1-4 (Table 2), respectively.

Figure 5 shows the variation in load sharing with changes in the input torque for a pinhole position error of 80 μm (Case 1, Table 2). The first gear mesh occurred at

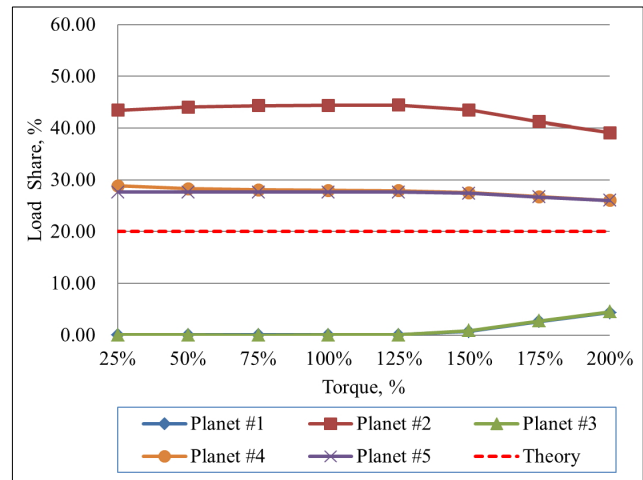

Figure 5. Analysis of load sharing among the planet gears in the PGS with respect to the input torque and pinhole position error for Case 1.

planet gear #2 because the sun gear, through which power was input to the PGS, rotated counter-clockwise. As a result of this rotation, planet gear #2 bore the largest load. Planet gears #1 and #3, which were located immediately on either side of planet gear #2, bore loads smaller than the theoretical loads. Meanwhile, planet gears #4 and #5, which were located at 144° on either side of #2, bore loads larger than the theoretical loads. Load sharing did not significantly change up to an input torque of 125% of the rated torque. However, the load sharing improved beyond this torque level. This improvement was attributed to the fact that pinhole position error mainly affects load sharing at small input torques. However, the effects of the stiffnesses of the planet pins and carrier became more dominant with increasing input torque (Bodas and Kahraman, 2004; Singh, 2005). The loads borne by planet gears #1-#5 at the rated input torque (100%) of the HMT system were 0%, 44%, 0%, 28%, and 28%, respectively.

Figure 6 shows load sharing among the planet gears with respect to the input torque for a position error of 40 μm at pinholes #2 and #4 (Case 2, Table 2). The meshes of planet gears #2 and #4 preceded those of the other gears in a counter-clockwise rotation. Hence, these two gears bore the largest loads. Gears #1 and #5 bore actual loads smaller than the theoretical loads. Further, gear #3 bore the smallest load. As in Case 1, load sharing among the gears did not change significantly until the input torque exceeded 125% of the rated value. Load sharing improved beyond this torque level. The load fractions borne by

Table 2. Pinhole position error in the planet carrier

| Case | Pinhole position error, μm | | | | |
|------|---------------------------------------|------------|------------|------------|------------|
| | Pinhole #1 | Pinhole #2 | Pinhole #3 | Pinhole #4 | Pinhole #5 |
| 1 | 0 | 80 | 0 | 0 | 0 |
| 2 | 0 | 40 | 0 | 40 | 0 |
| 3 | 0 | 40 | 0 | -40 | 0 |
| 4 | 0 | 0 | 0 | 0 | 0 |

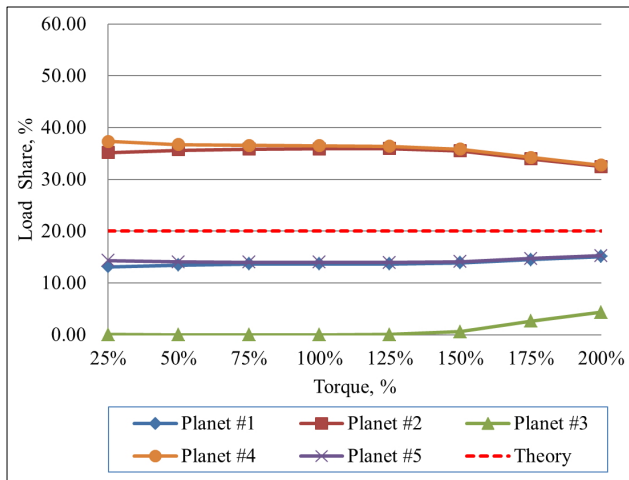

Figure 6. Analysis of load sharing among the planet gears in the PGS with respect to the input torque and pinhole position error for Case 2.

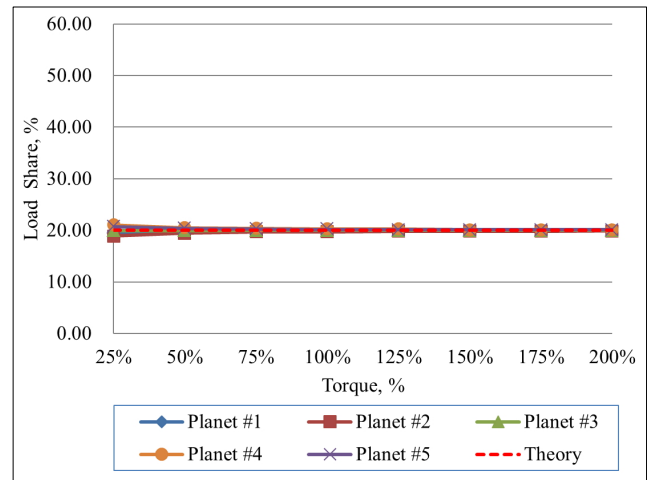

Figure 8. Analysis of load sharing among the planet gears in the PGS with respect to the input torque and pinhole position error for Case 4.

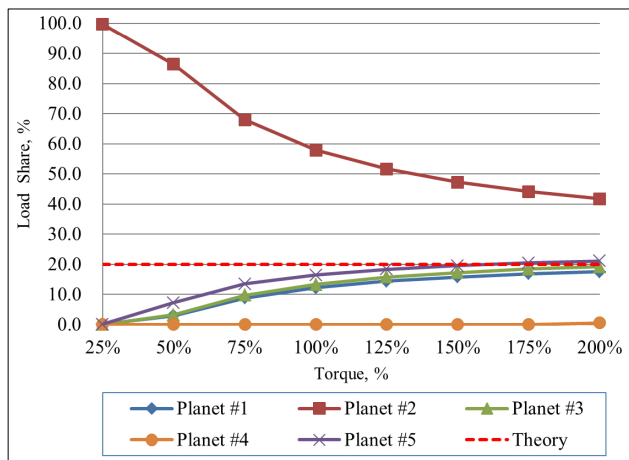

Figure 7. Analysis of load sharing among the planet gears in the PGS with respect to the input torque and pinhole position error for Case 3.

planet gears #1-#5 at the rated input torque (100%) were 13.5%, 36.0%, 0.0%, 36.5%, and 14.0%, respectively.

Figure 7 shows the load sharing among the planet gears with respect to the input torque for position errors of 40 and -40 μm at pinholes #2 and #4, respectively (Case 3, Table 2). The first gear mesh in a counter-clockwise rotation occurred at gear #2, which consequently bore the largest load. No gear mesh occurred at gear #4, which consequently did not bear any load, because the pinhole mispositioning occurred in the opposite direction. The load fraction of gear #2 was very high for a small ratio of the input torque to the rated torque. However, the load fraction of the gear decreased with increasing input torque. The load fractions of planet gears #1-#5 at the rated input torque (100%) were 12.3%, 58.0%, 13.2%, 0.0%, and 16.5%, respectively.

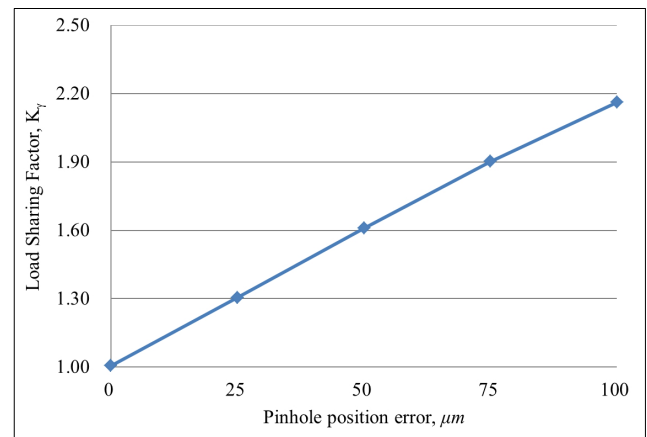

Figure 9. Load-sharing factor of planet gear #2 with increasing pinhole #2 position error and no other errors.

Figures 5-7 demonstrate that the unevenness of load sharing among the planet gears of the PGS decreased with decreasing pinhole position error and increasing input torque (Hidaka et al., 1979a, 1979b; Hayashi et al., 1986). In addition, at small input torques, pinhole position error was the dominant determinant of load sharing among the gears. Accordingly, the effects of the planet pin and carrier stiffnesses increased with increasing input torque.

Figure 8 shows the load sharing among the planet gears with respect to the input torque for a pinhole position error of 0 μm (Case 4, Table 2). The load was evenly shared by the gears because this was an ideal condition with no position error.

Figure 9 shows that planet gear #2 bore the largest load for increasing position errors of pinhole #2 of 0, 25, 50, 75, and 100 μm and no other pinhole errors in the

PGS; its load-sharing factors increased to 1.00, 1.31, 1.61, 1.90, and 2.16, respectively.

Conclusions

This study investigated the PGS of a HMT system in a tractor to determine how the position error in a pinhole in the carrier of the planet gears affected load sharing among the gears. A simulation model was developed using a commercial software (Romax Technology Ltd., 2003) to determine the load-sharing characteristics of the PGS. The model was verified by comparing its results with those of a previously developed model (Singh, 2005).

The following points summarize the findings of this study:

- The sequence of the load magnitudes borne by the planet gears for varying pinhole position errors of 0, 50, and $-50 \mu\text{m}$ was the same for both simulation models. However, the load magnitudes borne by the corresponding planet gears differed. This difference was attributed to the different PGS input torques and stiffnesses of the PGS components (i.e., gear, bearing, carrier, and planet pins). The load-sharing factors of the gears also differed because the input torque and the stiffnesses could not be duplicated in the two models. However, the similarity of the load magnitude sequences in the two simulation models verified the present model for predicting the load-sharing characteristics of the PGS gears.

- The present simulation model determined that the unevenness of load sharing among the planet gears decreased with decreasing pinhole position errors and increasing input torque.

- The pinhole position error in the carrier for small input torques to the PGS dominantly affected load sharing among the planet gears. The effects of the planet pin and carrier stiffnesses increased with increasing input torque.

- The unevenness of load sharing among the planet gears increased with increasing pinhole position error. Therefore, the error tolerance of the pinholes should be carefully considered when designing the planet carrier of a PGS.

Conflict of Interest

The authors have no conflicting financial or other interests.

References

- American Gear Manufacturers Association (AGMA). 2006. Design Manual for Enclosed Epicyclic Gear Drives. ANSI/AGMA 6123-B06.
- Bodas, A. and A. Kahraman. 2004. Influence of carrier and gear manufacturing errors on the static load sharing behavior of planetary gear sets. *JSME International Journal* 47(3):908-915.
- Goering, C. E., M. L. Stone, D. W. Smith and P. K. Turnquist. 2003. *Off-road Vehicle Engineering Principles*. Miami: The American Society of Agricultural Engineers (ASAE).
- Hayashi, T., Y. Li, I. Hayashi, K. Endou and W. Watanabe. 1986. Measurement and some discussions on dynamic load sharing in planetary gears. *Bulletin of the JSME* 29:2290-2297.
- Hidaka, T., Y. Terauchi and K. Dohi. 1979. On the relation between the run out errors and the motion of the center of sun gear in a Stoeckicht planetary gear. *Bulletin of the JSME* 22:748-754.
- Hidaka, T., Y. Terauchi and K. Nagamura. 1979. Dynamic behavior of planetary gear, 7th report, Influence of the thickness of the ring gear. *Bulletin of the JSME* 22: 1142-1149.
- International Organization for Standardization (ISO). 2003-2007. Calculation of load capacity of spur and helical gears. ISO:6336-(1:6).
- Kahraman, A. and S. Vijayakar. 2001. Effect of internal gear flexibility on the quasi-static behavior of a planetary gear set. *Transactions of the ASME* 123:408-415.
- Prueter, P. E., R. G. Parker and F. Cunliffe. 2011. A study of gear root strains in a multi-stage planetary wind turbine gear train using a three dimensional finite element/contact mechanics model and experiments. *Proceedings of the ASME 2011 International Design Engineering Technical Conferences & Computer and Information in Engineering Conference (IDETC/CIE 2011)*, Washington, DC, USA.
- Park, Y. J., G. H. Lee, J. S. Song and Y. Y. Nam. 2013. Characteristic analysis of wind turbine gearbox considering non-torque loading. *Journal of Mechanical*

Design 135(4):044501-(1:8).

Romax Technology Ltd. 2003. Romax Designer Software Manual. Nottingham, UK.

Singh, A. 2005. Application of a system level model to study the planetary load sharing behavior. Journal of

Mechanical Design 127:469-476.

Sung, D. H., H. E. Kim, G. H. Lee and H. S. Kim. 2001. Power transmission characteristics of a hydromechanical transmission. Transactions of the Korean Society of Mechanical Engineers A 25(11):1854-1862.