

# Efficient Numerical Analysis for Shape Design of Turbine Seal

Kyu-Taek Han<sup>\*,#</sup>

<sup>\*</sup>Department of Mechanical Engineering, Pukyong National University

## 효율적인 수치해석에 의한 터빈 시일의 형상설계

한규택<sup>\*,#</sup>

<sup>\*</sup>부경대학교 기계공학과

(Received 28 April 2016; received in revised form 30 May 2016; accepted 27 June 2016)

### ABSTRACT

In this paper, the model to develop the forming process for turbine seal is suggested. And numerical approach for the shape design of the turbine seal is examined. Because of the thin thickness of the turbine seal, the seal is easily fractured in the manufacturing process. The main factors of the seal manufacturing consist of addendum angle and dedendum angle, fillet on the addendum face, number of the gear teeth, sheet initial location and gear initial location, rake and vertical clearance. The structure and shape of seal are modeled using the commercial 3D mechanical design program, CATIA(V5/R20). Also, rolling process to manufacture the turbine seal is analyzed using DEFORM<sup>TM</sup>-3D(V11), commercial forming analysis software and runs under PC workstation. This study focused on the shape design of turbine seal. Through this research, the main factors to make the turbine seal for airplane turbine engine can be obtained. This study results are reflected to the shape design for turbine seal.

**Keywords :** Turbine Seal(터빈 시일), Forming Process(성형공정), Rolling Process(압연공정),  
Honeycomb Structure Seal(하니컴구조 시일), Finite Element Analysis(유한요소해석)

## 1. Introduction

Honeycomb core materials are widely used in the manufacture of stiff, lightweight sandwich panels mainly for use in aircraft. Commercial honeycombs are most commonly based on a hexagonal cell

shape which is simple to produce and ideal for the manufacture of flat sandwich panels. A disadvantage of the hexagonal cell honeycomb is that if it is bent out-of-plane it produces an anticlastic or saddle-shaped curvature due to the effective in-plane Poisson's ratio being positive. With such a honeycomb doubly curved structures can only be produced by forcing a sheet of honeycomb into the desired shape, causing local crushing of the cells, or by machining a block to the required profile which

# Corresponding Author : [kthan@pknu.ac.kr](mailto:kthan@pknu.ac.kr)  
Tel: +82-51-629-6135, Fax: +82-51-629-6126

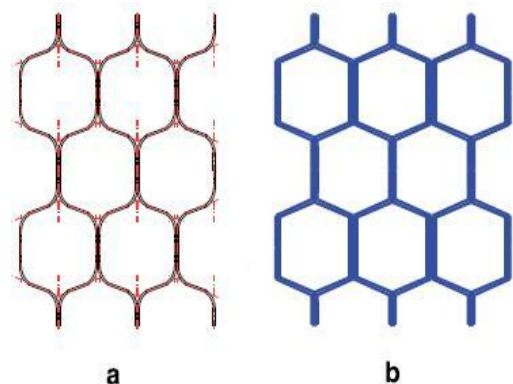
is expensive. However, if the effective Poisson's ratio is made negative by altering the cell shape the domed or synclastic curvatures can be achieved naturally<sup>[1]</sup>. Honeycomb products are typically lighter in weight than corresponding solid products, use less material, are less expensive to manufacture and utilize, and provide satisfactory durability and strength for most applications<sup>[2-3]</sup>. All commercial honeycombs do have a curved wall at the intersection points and the value of the radius of curvature depends on the specific honeycomb. A general model that accounts for the curvature at the intersection points of hexagonal honeycombs is to predict their effective bending, axial, and shear deformations<sup>[4]</sup>. As the increase of the utilization in automobile, aerospace and electrical fields, there has been a growing interest in the forming of honeycomb core. And the honeycomb core is the basic of the turbine seal. Because of the precision shape and the thin thickness, the honeycomb core is not easy to manufacture in the metal forming process. The standard honeycomb has a uniform hexagonal structure defined by the material, cell size, cell wall thickness and bulk density. The main constructional materials are aluminum, glass fiber reinforced plastic and aramid paper. If a honeycomb structure is compressed in the thickness direction, the cell walls first bend, giving linear elastic deformation. Cell collapse ends once the opposing cell walls begin to contact each other<sup>[5]</sup>. The first step analyzing of die design is production part review, then the arrangement drawing of product design and strip process layout design should be done as a next steps with a FEM simulation for its problem solution. The result of simulation will give engineers good information to access the forming technique on sheet alloy. And its application is being increased especially in the production for the cost reduction, saving of defective ratio, and improvement of productivity. Also the final shape of a material point can be also predicted by integrating

a deformation gradient along a stream line based on computer simulation<sup>[6-10]</sup>.

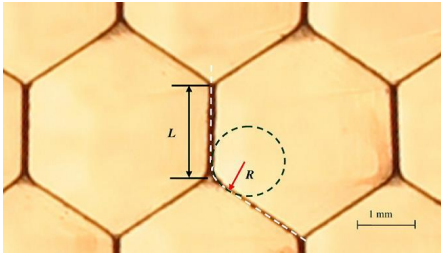
As mentioned above, there have been researches concerned with honeycomb products, but there has been no research that tried to analyze and design the shape of turbine seal. Therefore, the shape design of turbine seal is of increasing importance. Because of the whole forming process to manufacture the turbine seal is complicate, The objective of this research is to find out the turbine seal shape which is close to the standard shape for airplane turbine engine by numerical analysis. Through this research, the optimal parameters of honeycomb seal for turbine can be obtained. This study results are reflected to the shape design for turbine seal.

## 2. Definition of Hexagonal Honeycomb

The schematics of a commercial honeycomb with curved walls at the intersection points and a straight-walled honeycomb are shown in Fig. 1a and b, respectively. A magnified photograph of a studied commercial honeycomb is presented in Fig. 2 and it shows that the curvature in the walls at the intersection points<sup>[3]</sup>.

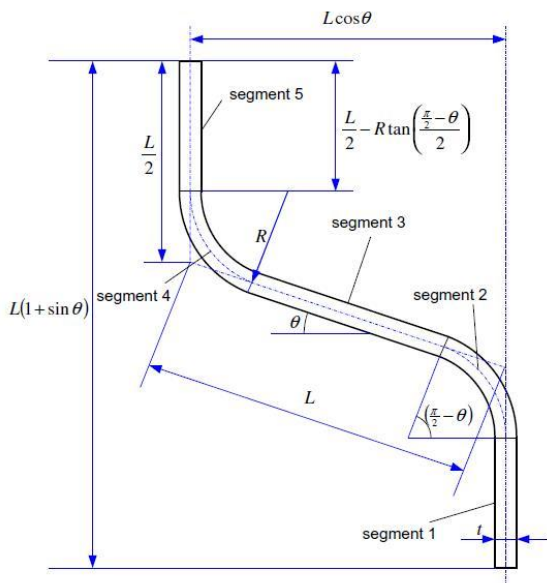


**Fig. 1 Regular hexagonal honeycomb structure: (a) commercial honeycomb with curved walls at the intersection points; (b) theoretical honeycomb with straight walls**



**Fig. 2 Photograph of a commercial honeycomb showing the radius of curvature at the intersection point**

Fig.3 shows the isolated unit cell that includes five distinct segments: two vertical straight portions; an inclined straight portion and two curved portions. The angle defining the fillet is described in terms of the nominal inclination for the general honeycomb; i.e.,  $\theta$ . This angle changes as  $\theta$  changes and takes the value of  $(\frac{\pi}{2}-\theta)$  as shown in Fig.3. The inner fillet radius is  $(R-\frac{t}{2})$  and the outer radius is  $(R+\frac{t}{2})$ , where  $R$  is the centerline fillet radius, and  $t$  is the wall thickness.



**Fig. 3 A general hexagonal honeycomb with curved walls at the intersection points**

### 3. Forming Process of Turbine Seal

#### 3.1 Honeycomb seal

Fig.4 shows the honeycomb members after cutting process and Fig.5 shows assembly of the honeycomb seal after welding process. The specification and material property of the honeycomb are shown in Table 1 and Table 2. The dimensions of Table 1 are based on those of the standard seal for airplane turbine engine.

**Table 1 Specification of honeycomb**

Specification	Value
Edge length	4 mm
Width	4 mm
Cell wall thickness	0.3 mm
Half-hexagonal size	3.2 mm
Centerline fillet radius	0.02 mm
Material	Inconel-718

**Table 2 Material property of the honeycomb**

Property	Value
Density	8.19 g/cm <sup>3</sup>
Tensile strength	1240 MPa
Yield point	1036 MPa
Elongation in 50mm	12 %
Hardness	36 HRC



**Fig. 4 Honeycomb members**



Fig. 5 Assembly of the honeycomb seal

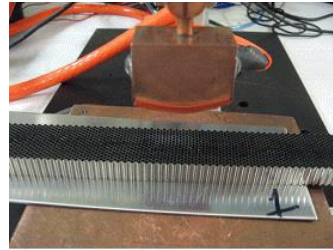
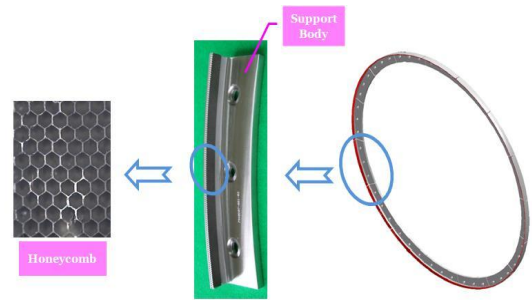


Fig. 7 Welding process of the honeycomb seal

### 3.2 Turbine seal process design

The forming process of the honeycomb seal is shown in Fig.6. In the rolling process, the sheet is involved into two gears to form the honeycomb shape. In the cutting process, the sheet after the rolling process will be divided into several parts and each width is 4mm. The divided sheets are stacked into a honeycomb shape. And after welding process the forming of honeycomb seal is finished. Fig.7 shows the welding process of the honeycomb seal and Fig.8 shows the assemble part of the honeycomb seal.



Static Honeycomb Seal Diameter Ø1,600 mm / 1 SET(Ring) = 16 segments

Fig. 8 Assemble part using honeycomb seal

### 4. Rolling Process Analysis

The forming process using rolling process, illustrated in Fig. 6, is the original technique used to fabricate honeycomb core. Although it is labor intensive, this method is still used for making high density metallic and some nonmetallic cores. In the corrugation process the sheets are first corrugated, then adhesive is applied to the nodes and the sheets are stacked and cured in an oven. Since only light pressure can be applied to the stacked block the node adhesive is much thicker than the expanded core. In fact the corrugate node adhesive can be 10% of the total honeycomb weight while it is only about 1% or less in the expanded core. Some nonmetallic corrugated blocks must be brought up to final density by resin dipping to achieve the optimum resin-to-reinforcement ratios.

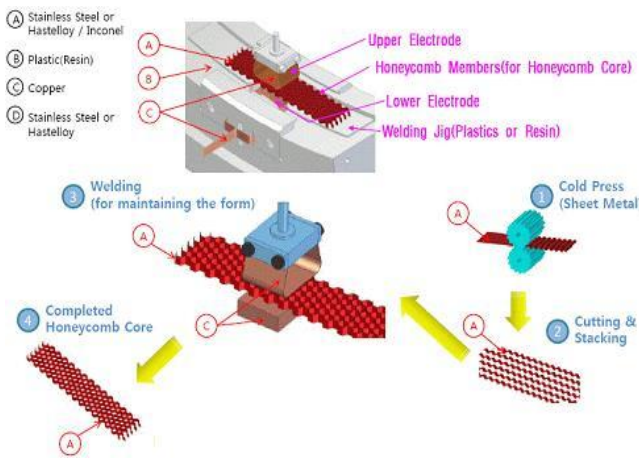


Fig. 6 Forming process to manufacture turbine seal

The honeycomb member shape is the basic of the honeycomb core. The rolling process is very important in the whole process. So the rolling process will be simulated in the paper.

#### 4.1 Modeling

The structure and shape of elements are modeled using the commercial 3D mechanical design software, CATIA(V5/R20). In order to keep the sheet at the horizontal plane, a guide is applied in the simulation. Fig.9 shows modeling elements. The sheet material is assumed rigid-plastic as shown the Fig.9(a). Also the sheet guide and gear are assumed to the rigid body as shown in Fig.9(b), Fig.9(c). Fig.10 is the assembly of the simulated elements.

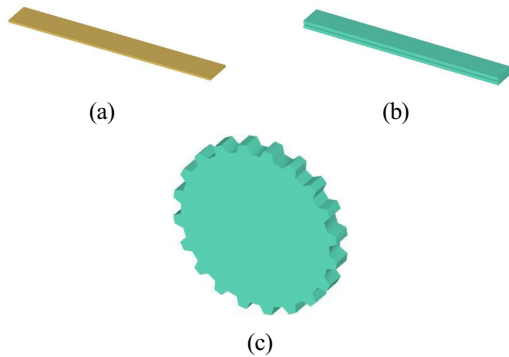


Fig. 9 Modeling elements

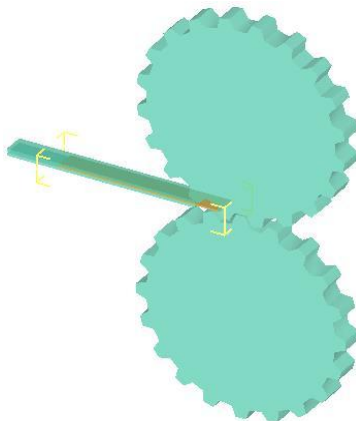


Fig. 10 Assembly of the elements

#### 4.2 Meshing

Solving the rolling process problem by three dimensional modeling instead of two dimensional analysis is used due to sheet characteristics. The mesh condition is shown in Table 3.

Table 3 Meshing condition

Factor	Value
Number of nodes	16433
Number of elements	60529
Surface polygons	23728
Minimum element size	0.0943882 mm
Maximum element size	0.188776 mm

#### 4.3 Simulation

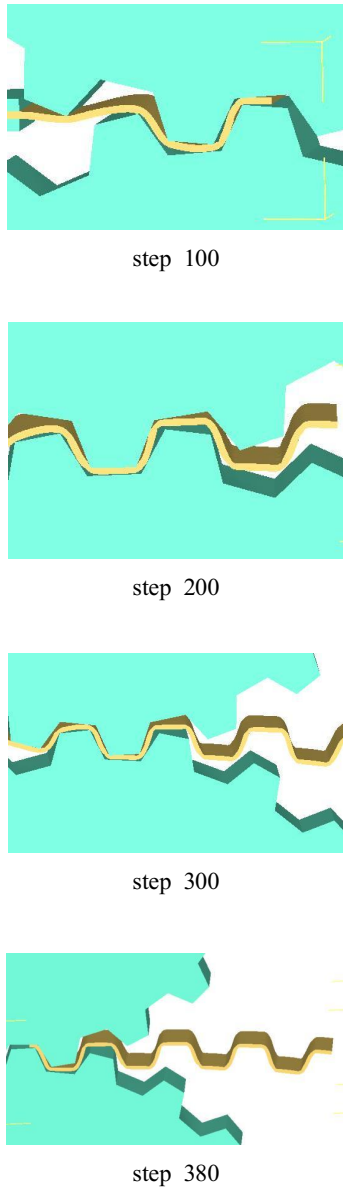
The constant physical properties in the analysis are shown in Table 4.

Table 4 Simulation parameter

Parameter	Value
Temperature	20 °C
Time increment	0.01 s
Gear speed	0.5 rad/s
Friction coefficient	0.12
Number of simulation steps	0.188776 mm

The rolling process to manufacture turbine seal is analyzed using DEFORM<sup>TM</sup>-3D(V11), commercial forming analysis software and runs under PC workstation. In order to analyze the problem, the initial sheet thickness is selected 0.3mm based on the dimension of standard seal for airplane turbine engine, the vertical gear clearance is 0.3mm. Also a gear corner R(0.02mm) on the addendum face of gear is applied to reduce the stress concentration.

The forming process of honeycomb member is shown in Fig.11. The sheet initial location affects the entrance angle in the simulation.



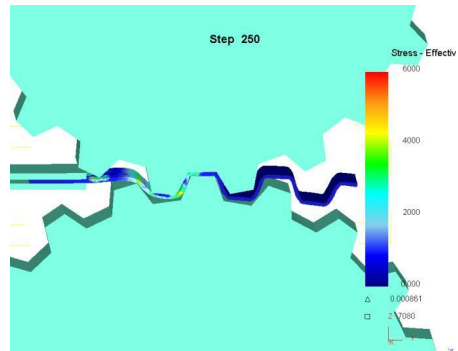
**Fig. 11 Shear section of the simulation results**

The proper sheet initial location can reduce the stress concentration at the entrance point. The gear initial location affects the sheet how to involve into the gear, the better way is to bend a corner than turn

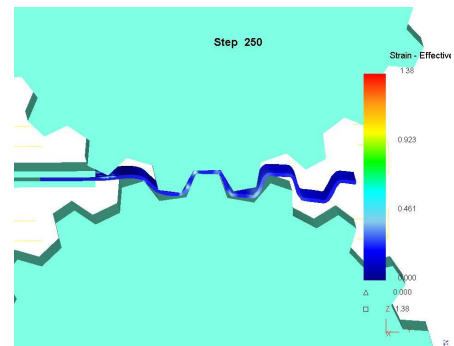
a corner while the sheet is being involved into the gear.

## 5. Results and Discussion

Fig.12 and Fig.13 show the stress-effective and strain-effective at step 250. We can see that the sheet is involved into the gears during the gears rotating from Fig.11. After the rolling process, the shear section of honeycomb is closed to the standard shape. From Fig.12 and Fig.13, the stress-effective and strain-effective are small after the rolling process, which means that the residual stress and residual strain are acceptable in the process<sup>[11]</sup>.



**Fig. 12 Distribution of stress at step 250**



**Fig. 13 Distribution of strain at step 250**

As radius of gear increases, the fillet on the honeycomb sheet corner increases, and the stress distribution in the rolling area is small. Thus a large fillet on the addendum face can reduce the stress concentration to extend the gear life and avoid the sheet fracture. Through this research it was confirmed that after the rolling process, the section of honeycomb seal close to the standard shape for airplane turbine engine can be obtained. Also research results can be extended to apply to the manufacturing of various honeycomb products.

## 6. Conclusion

In this study, the forming process of turbine seal is developed and the rolling process is analyzed. The conclusions of this study obtained can be summarized as follows:

1. The honeycomb seal can be formed through rolling process using gear mechanism.
2. The shear section of turbine seal is closed to the standard hexagonal honeycomb shape.
3. when sheet material is inserted into the gear mechanism, the insert initial location of the sheet material and the sheet guide have to be considered.
4. The effective-stress and effective-strain are small after rolling process, so residual stress and the residual strain are negligible in the process.
5. In the forming process of turbine seal, the rolling process, cutting process and welding process are included.
6. In the future, the bonding process of honeycomb core and support metal will be studied.

## Acknowledgement

This work was supported by a Research Grant of Pukyong National University(2016 year)

## REFERENCES

1. Masters, I. G., and Evans, K. E., "Models for the elastic deformation of honeycombs," pp.403, 1996.
2. Hayes, M. W., Degrange, J.E., Rice, C. V. and Polus, J. E., "Improved Honeycomb Cores for Aerospace Applications," pp.3-7, 2004.
3. Han, S. W., and Kim, H. J., "Experimental Study on Shape Machining Characteristics of Composite Honeycomb Core," KSMPE, Vol.13, No.4, pp.28-35, 2014.
4. Balawi, S., and Abot, J. L., "A refined model for the effective in-plane elastic moduli of hexagonal honeycombs," pp.147-158, 2008.
5. Aktay, L., Johnson, A. F. and Kroplin, B. H., "Numerical modeling of honeycomb core crush behavior," pp.2616-2630, 2008.
6. Sim, S. B., and Kim, C. H., "A Study on the Multi-row Progressive Die for Thin Sheet Metal Forming by Computer Simulation," KSMPE, Vol.7, No.3, pp.36-43, 2008.
7. Kobaysahi, S., Oh, S. I. and Altan., T., "Metal forming and the finite element method," Oxford University Press. 1989.
8. Son, Y. G., Jeong, D. W., "A Study on Static-Implicit Forming Analysis of the Magnesium Alloy Sheet," J. of KSMPE, Vol.7, No.4, pp.44-49, 2008.
9. Shin, Y. J., Choi, C. H., Lee, S. G. and Kim, J. H., "Fatigue CAE Analysis of a Rebar Bending Machine Roller," J. of KSMPE, Vol.14, No.2, pp.75-80, 2015.
10. Kim, T. H., Jang, J. H., Lee, D. G., Kim, L. S., and Lyu, S. K., "Study on Optimal Design and Analysis of Worm Gear Reducer of High Place Operation Car," J. of KSMPE, Vol.14, No.6, pp.98-103, 2015.
11. Gibson, L. J., and Ashby, M. F., "Structure and properties", Cambridge University, 1997.