

Adaptive method for selecting Cluster Head according to the energy of the sensor node

Yong Min Kim¹, WooSuk LEE², Oh Seok Kwon², Kyedong Jung³ and Jong-Yong Lee^{3*}

^{*1}Research Institute, CHAMSULE TECH, Seoul, Korea.

²Department of Plasma Bioscience and Display, KwangWoon University Graduate School, Seoul, Korea.

³Ingenium college of liberal arts, KwangWoon University, Seoul, Korea.

e-mail : dggjelly@naver.com, {leewoosuk, ohskwon, gdchung, *jyonglee}@kw.ac.kr

Abstract

The most important factor in the wireless sensor network is the use of effective energy and increase in lifetime of the individual nodes in order to operate the wireless network more efficiently. For this purpose, various routing protocols have been developed. The LEACH such a protocol, well known among typical cluster routing protocols. However, when a cluster head is selected, the energy consumption may not be equal because it does not take into account the energy of the nodes. In this paper, we seek to improve the cluster head selection method according to residual energy of each sensor node. This method then adaptively applies the LEACH algorithm and the cluster head section algorithm with consideration of node energy in accordance with the energy of the whole sensor field. Through the simulation, it was found that this proposed algorithm was effective.

Keywords: *Wireless Sensor Network, Routing Protocol, LEACH, Adapting Algorithm, Energy Efficiency.*

1. Introduction

Sequence alignments are required to find the structural information on the proteins of unknown structure. If satisfactory multiple alignments are achieved for transmembrane (TM) proteins, we may predict the TM topology and the functional similarity of the proteins with some transmembrane segments (TMSs) [1]. Indeed, a few interesting methods for multiple alignment of TM protein sequences have been proposed [2, 3]. However, sufficient multiple alignment in a conventional manner is difficult most likely because of diversities of the sequences in data sets. Sequence alignments and their analyses are dependent on the pairwise sequence identity in the data set. The twilight zone of 20–35 % sequence identity has been discussed [4, 5].

In the present study, we attempt a sequence selection as a pre-treatment for the multiple alignments of TM protein data sets. Our immediate aim is obtaining the aligned sequences with less inserted gaps combined with TM topology prediction. The procedure of the treatment is developed using the pairwise sequence identities. The treatment is carried out for ten sequence data sets of functional group of polytypic TM proteins extracted from SWISS-PROT. Two new indices are introduced for the evaluation of multiple sequence alignments of TM proteins: the degree of TMS position diversity, P, and the degree of gap insertion into TMS, G.

The treatment is effective in excluding the sequences with low sequence identity from the divergent data sets. If we can determine a suitable threshold value of sequence identity, the obtained data set seems to be worthwhile. The selected sequences must be valuable for extracting the structural features of polytypic TM functional groups. The properties of our sequence selection treatment and the resultant multiple alignments are discussed.

2. Related Research [2, 3]

The LEACH (Low Energy Adaptive Clustering Hierarchy) Protocol is a typical hierarchical routing protocol on the basis of the clustering. The LEACH divides the sensor field into the specified number of clusters, and each cluster consists of a cluster head and the member node. That is, LEACH has a hierarchical structure. The CH performs to collect data from the cluster member nodes and it will be transmitted to the BS (Base Station). The cluster structure of the LEACH is shown in Figure 1 below.

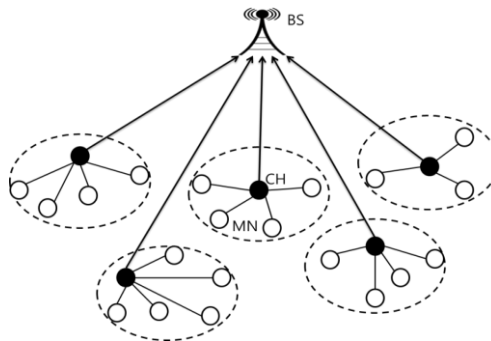

Figure 1. The Cluster configuration of LEACH

Since the node which is selected as the cluster head consumes more energy than the member node in the cluster, the entire node is to be selected evenly the cluster head on based stochastic equation. In addition, the cluster head aggregates the redundant data, do not transmitted the unnecessary data to the BS. LEACH is composed of the set-up and steady-state phase. The set-up phase is used the following probability formula - stochastic threshold, the cluster head election is done stochastically [2, 3].

$$T_1(n) = \begin{cases} \frac{p}{1-p(r \bmod \frac{1}{p})} & \text{if } n \in G \\ 0 & \text{otherwise} \end{cases} \quad (1)$$

The $T(n)$ in the above equation (1) is a threshold value for comparing the random number, the set G is the set of nodes that did not cluster, the r represents the current round. Comparing the random number between 0

and 1 and $T(n)$, if the $T(n)$ is greater than any random number, the n -th node is selected as the cluster head. After the cluster head is elected, the cluster head sends a broadcast message to the general node surroundings of CH. Normal nodes transmits a Join-Request message to the cluster head to join the cluster. Through this process, the entire sensor network consists of a multitude of clusters, the cluster head transmits the assigned time slot by the TDMA schedule to the general node belonging to the own cluster. In the steady state, according to the scheduling of clusters set by the setting state, the normal node transmits the collected data to CH through the time slot assigned by the CH. The cluster head collects the data, is transmitted to the BS by CDMA transmission method. If the setup phase and steady-state illustrates the same as the figure 2 below, this process is defined as a round.

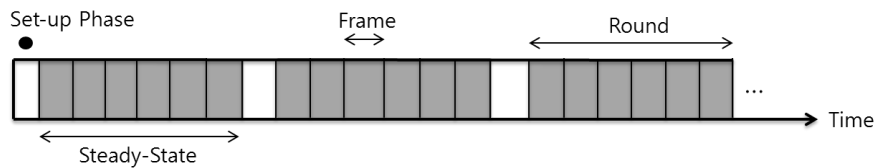

Figure 2. The Cluster configuration of LEACH

When the cluster member usually are in sleep status, if the node is a transmission time, wakes up, transmits the data and returns back to the sleep state after transmitting the data. Because the nominal nodes are sleep state in a state other than the transmission, can reduce the energy consumption.

The flow chart of LEACH is shown below figure 3 [7].

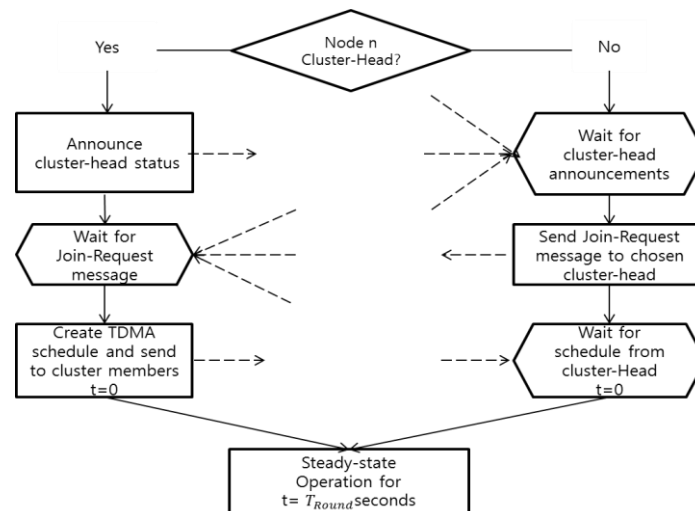

Figure 3. The Flow Chart of LEACH

The advantage of LEACH is as follows.

- It is a simple algorithm and shows a significantly higher efficiency.
- Each sensor node is alternately takes on the role of the cluster head, thereby it is increasing the life time of the network because of the energy consumption.
- The cluster head merges the duplicate data so that unnecessary data is not transmitted.

The disadvantage of LEACH is as follows.

- When it is selecting a cluster head, it does not take into account the energy of the nodes.
- In the network that the total amount of data throughput is irregular, it will be poor efficiency.
- Cluster head is located far from the BS to consume that much larger transfer of energy because the communication distance far shorter overall network lifetime.

3. Proposed algorithm

When the LEACH is to select a cluster head, it does not consider the residual energy of the node. Any node which is insufficient the residual energy can be elected as the cluster head by the Stochastic Threshold expression. In this case, the first dead node can occur quickly in the sensor network. Therefore, the energy consumption of the sensor network composed of the imbalance, the life cycle of the network can be shortened. In this paper, we were added to the residual energy term in Stochastic Threshold formula to improve disadvantages of the LEACH. First, the node of a large residual energy is selected as the cluster head, the equation (1) was multiplied by the ratio of the initial energy E_{max} of the residual energy E_{res} of the nodes. And because the residual energy ratio of the node is decreasing, it is compensated the energy efficiency by a multiple of the cluster selection probability (p). As a result, the considered stochastic formula is shown in (2).

$$T_2(n) = \begin{cases} \frac{p}{1-p(r \bmod \frac{1}{p})} \left(2p \times \frac{E_{res}}{E_{max}} \right) & \text{if } n \in G \\ 0 & \text{otherwise} \end{cases} \quad (2)$$

The equation (2) - $T_2(n)$ - has the advantage that the energy consumption of the node is equally possible by considering the residual energy selecting a cluster head. The range of $T_2(n)$ is limited to the $2p^2 \frac{E_{res}}{E_{max}} \leq T_2(n) \leq 2p \frac{E_{res}}{E_{max}}$. Comparing the range that is represented by $p \leq T_1(n) \leq 1$ in the Eq. (1) and $T_2(n)$, $T_2(n)$ has a value in a narrower range. This means that the probability of the selection for the cluster head is uniformly, it will be verified by simulation. As the round is increased, the $\frac{E_{res}}{E_{max}}$ will also converge to zero because of the residual energy of the network converges to zero as shown in Figure 4.

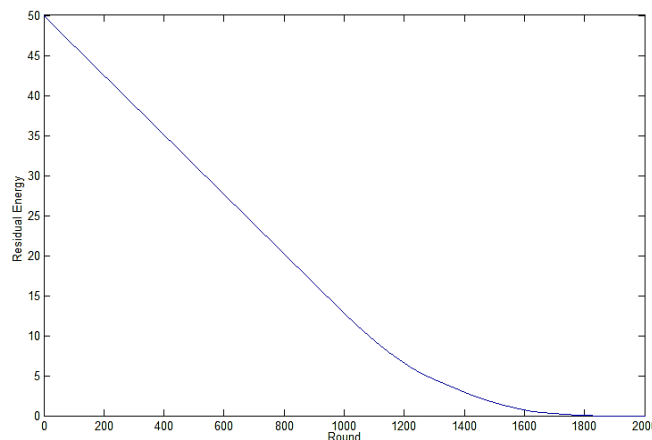

Figure 4. The Residual Energy for The Round

As a result, when it has selecting the cluster head using the $T_2(n)$, it may increase the energy efficiency initially, but if the round is increased, the value of $\frac{E_{res}}{E_{max}}$ is as closer to zero. Then the round can occur unless the cluster head is selected. That is, after a long of time is passed, the $T_2(n)$ has the disadvantage that the selection of the cluster head is not good to compare with the $T_1(n)$. In this paper, we proposed the dual selection method according to the node energy. The proposed method is that it has selected the cluster head using the equation (2) until the residual energy of the node is greater than or equal to 50%, and when the residual energy of the node is less than 50%, it has elected the cluster head using the equation (1). The proposed method was compared with the LEACH algorithm.

4. Simulation and Result

In order to verify the proposed algorithm, it is considered the energy consumption model of a node as in Figure 5 below. The parameter's value of the energy consumption model was described in Table 1. And it assumed that all of the initial energy of each node is the same, it was simulated using the MATLAB [3].

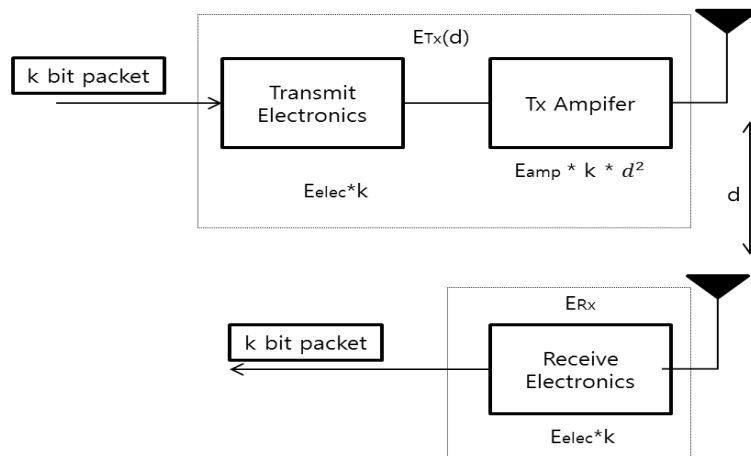

Figure 5. The Energy Consumption Model

Table 1. The Parameter of the Energy Consumption Model

| Parameter | Description | Value | Parameter | Description | Value |
|-----------------|----------------------------|--------------------------|------------------|-----------------|--------------------------|
| E_{elec} | Circuit energy consumption | | E_{DA} | Aggregation | |
| ϵ_{fs} | Free space loss | 0.13J/bit/m ⁴ | ϵ_{amp} | Multipath loss | 100pJ/bit/m ² |
| n | Number of node | 100 | E_{max} | Initial energy | 0.5J |
| E_{TX} | Transmitted energy | 50nJ/bit | E_{RX} | Received energy | 50nJ/bit |

The size of the sensor field is 100 * 100m. And in order to compare the performance of the proposed algorithm, we were compared with the LEACH, Eq. $T_2(n)$.

The energy consumption of each node for 100, 300 and 500 round is represented the table 2 and figure 6.

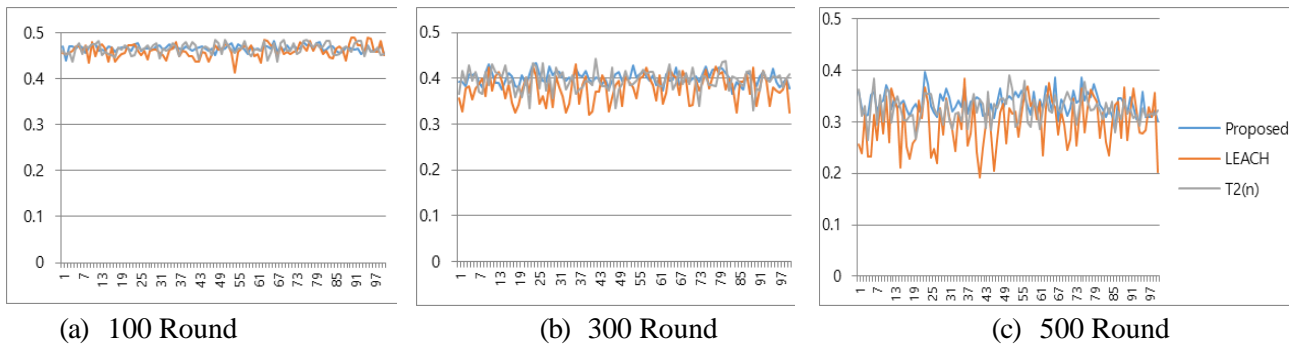

Figure 6. The Residual Energy for 100, 300, 500 round of each nodes

Table 2. The Compare Value of Each Nodes

| Round | Items | Proposed Method | LEACH Protocol | Relative comparison |
|-------|--------------------|-----------------|----------------|----------------------|
| 100 | Average | 0.466612155 | 0.459208185 | 1.6% Increase |
| 300 | | 0.401560601 | 0.379053603 | 5 % Increase |
| 500 | | 0.335957528 | 0.30878745 | 8% Increase |
| 100 | Variance value | 4.46945E-05 | 0.000147577 | 69% Decrease |
| 300 | | 0.000198643 | 0.000832296 | 76% Decrease |
| 500 | | 0.000452859 | 0.002106977 | 78% Decrease |
| 100 | Standard deviation | 0.006685394 | 0.012148128 | 44% Decrease |
| 300 | | 0.014094077 | 0.028849548 | 51% Decrease |
| 500 | | 0.021280485 | 0.045901819 | 53% Decrease |

As it summarized in Figure 6 and Table 2 above, the variance and standard deviation for the residual energy of node for each round was reduced by more than 69% and 44%. This means that the proposed method is equal to the residual energy of each node than LEACH. It indicates that the proposed method is that the energy is uniformly used by the node. Also, the remaining amount of energy for the proposed method is at least 1.6% higher than LEACH. This means that it is using energy more efficiency than LEACH.

Next, results of surviving node which indicates the performance index of a wireless sensor network is shown in Figure 7 and Table 3.

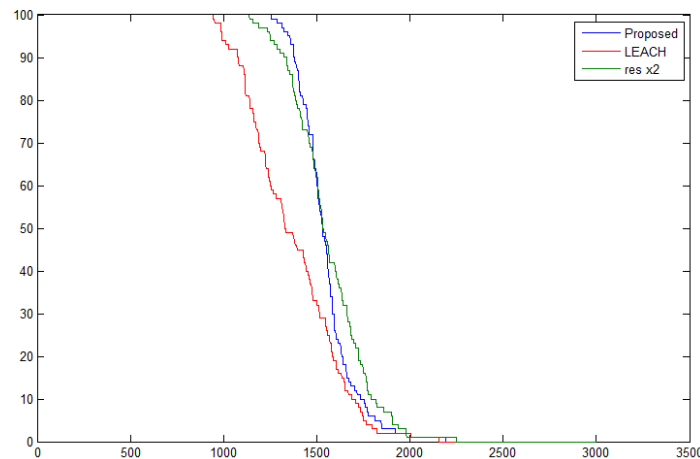

Figure 7. Alive node for the proposed method, LEACH and $T_2(n)$

Table 3. The Comparison of FND, HND and 80% DN for the proposed method, LEACH and T2(n)

| Round | Proposed Method | LEACH Protocol | $T_2(n)$ LEACH | Increase |
|---------------|-----------------|----------------|----------------|------------|
| FND | 1237 | 944 | 1187 | 31% |
| HND | 1531 | 1237 | 1539 | 23% |
| 80% Dead Node | 1643 | 1537 | 1924 | 6% |

As it summarized in Figure 7 and Table 4 above, the FND (First Node Dead), HND (Half Node Dead) and 80% Node Dead was improved by 31%, 23% and 6% than LEACH. Also, the round of the non-selected cluster head is shown in the following table 4.

Table 4. Round of the non-selected cluster head

| Round | Proposed | LEACH Protocol | $T_2(n)$ LEACH |
|---|---------------|----------------|----------------|
| Round number without cluster head | 399 | 312 | 952 |
| Round rate without cluster head of 80% Dead Node | 24.28% | 20.3% | 49.48% |

Non-selecting of the cluster head means that the transmission of data does not occur. Although the proposed method is reduced 4% than the LEACH, it was supplemented by improvement in the FND and HND.

Next, in order to compare the energy consumption of the proposed algorithm and LEACH, it was used for the formula (3) below.

$$\text{Ratio of the Energy Consumption} = \frac{\text{FND occurred Total Energy Consumption}}{\text{FND occurred round}} \quad (3)$$

Table 5. The Ratio of the Energy Consumption for the Proposed Method and LEACH

| | Proposed Method | LEACH Protocol | Increase |
|-------------------------|-----------------|----------------|------------|
| LEACH FND comparison | 0.033611916 | 0.03721074 | 10% |
| Proposed FND comparison | 0.0344033120 | 0.035728818 | 5% |

As shown in the above Table 5, it shows that the proposed method is efficient use of energy consumption than the LEACH. From the simulation result, the proposed algorithm was verified well than the LEACH.

5. Conclusion

In this paper, we proposed the algorithm for improving the disadvantage of the LEACH protocol. It is that the LEACH made to the energy consumption imbalance. To improve this, we propose a probability equation according to the remaining energy of the sensor. According to the total energy of sensor field, the LEACH protocol and the proposed algorithm for the selecting the cluster head were applied with the sensor field. The FND was improved by 31% compared with the proposed method LEACH, the proposed method is that the energy is uniformly used by the node. In this paper, the proposed method showed better than existing methods LEACH.

References

- [1] F. L. LEWIS "Wireless Sensor Networks" To appear in Smart Environments" Technologies, Protocols, and Applications ed. D.J. Cook and S.K. Das, John Wiley, New York, 2004.
- [2] J. Y. Lee, K. Jung, H. Jung, D. Lee "Improving the Energy Efficiency of a Cluster Head Election for Wireless Sensor Networks" *International of Distributed Sensor Networks*, Volume 2014 (2014)
- [3] J. Y. Lee, K. Jung, B. Shrestha, J. Lee and S. Cho "Energy Efficiency Improvement of the of a Cluster Head Selection for Wireless Sensor Networks" *International Journal of Smart Home*, Vol.8, No.3 (2014)
- [4] W. B. Heinzelman, Member "An Application-Specific Protocol Architecture for Wireless Microsensor Networks" IEEE, Anantha P. Chandrakasan, Senior Member, IEEE, and Hari Balakrishnan, Member, IEEE, 2004.
- [5] W. R. Heinzelman, A. Chandrakasan, and H. Balakrishnan "Energy-Efficient Communication Protocol for Wireless Microsensor Networks" *Proceedings of the 33rd Hawaii International Conference on System Sciences* - 2000.
- [6] M. J. Handy, M. Haase, D. Timmermann "Low Energy Adaptive Clustering Hierarchy with Deterministic Cluster-Head Selection" *IEEE Mobile and Wireless Communications Network*, 2002. 4th International Workshop on.
- [7] Y. M. Kim, C. Lee, K. Jung, and J. Y. Lee, Abdul Hanan Abdullah "The Routing Technology of Wireless Sensor Networks Using the Stochastic Cluster Head Selection Method" *The Institute of Internet, Broadcasting and Communication* 2014.
- [8] Y. Y. Choo, H. J. Choi, J. W. Kwan "Algorithm Improving Network Life-time Based on LECH Protocol" *The Korean Institute of Communications and Information Sciences*, 10-08 Vol. 35 No 8.