

Systems Engineering Method to Develop Multiple BMI Nozzle Inspection System for APR1400

Khaled Atya Ahmed Abdallah, Gunglhn Nam*

KEPCO International Nuclear Graduate School, South Korea

Abstract : The Systems Engineering (SE) approach is characterized by the application of a structured engineering methodology for the design of a complex system or component. In this study, the SE methodology is used to design a nondestructive inspection system for Bottom Mounted Instrumentation (BMI) nozzles. We developed a system that enables nondestructive inspection of BMI nozzles during regular refueling outage without removing the reactor internals. A special ultrasonic (UT) probe is introduced to scan and detect cracks within the weld region of the nozzle. A 3D model of the inspection structure system was developed along with the reactor pressure vessel (RPV) and internals which permits a virtual 3D simulation of the operation to check the design concept and effectiveness of the system and to provide a good visualization of the system. This approach allows for a virtual walk through to verify the proposed BMI nozzle inspection system.

Key Words : Systems engineering; BMI; BMI weld inspection, RV internals; Inspection; Nondestructive Test

Received: November 11, 2015 / **Revised:** June 20, 2016 / **Accepted:** June 22, 2016

* 교신저자 : Gunglhn Nam, inamgung@kings.ac.kr

This is an Open-Access article distributed under the terms of the Creative Commons Attribution Non-Commercial License(<http://creativecommons.org/licenses/by-nc/3.0>) which permits unrestricted non-commercial use, distribution, and reproduction in any medium, provided the original work is properly cited.

1. Introduction

The Systems Engineering (SE) approach is characterized by the application of a structured engineering methodology for the design of a complex system or component [1].

BMI nozzles in bottom head of the nuclear vessel are one of the pressure boundaries in the reactor coolant system. The BMI nozzle welds is known to be susceptible to stress corrosion cracking. Hence it requires careful inspection and maintenance.

The BMI nozzle welds regions have high possibility of primary water stress corrosion cracking (PWSCC). BMI nozzle is located at the lower plenum of reactor lower head, hence the inspection of BMI nozzles is not easy since access to the BMI nozzle is limited from inside and confined from outside as well and it is a high radiation area.

Although operating temperature is lower than the upper head of the nuclear reactor pressure vessel, the BMI nozzle region has a high possibility to generate PWSCC according to recent report, the problem formulation is described in figure 1. In 2003, two of South Texas Project 1 (STP-1) reactor BMI nozzles were found to be leaking due to boron acid [2-3]. It required extensive inspection, analysis, test and repair of RPV lower head BMI nozzle by half-nozzle repair and replacement method [4]. BMI nozzles have not been inspected until then during regular overhaul periods for fuel re-placement due to its relative small size and limited impact on plant operation. However, there is growing concern since the leaks at STP-1 nuclear power plants (NPPs).

When applying the SE approach to the design

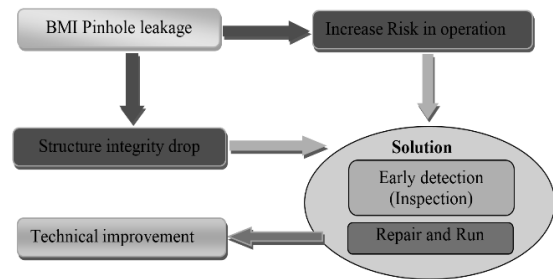

[Figure 1] Problem formulation

of the BMI nozzle inspection system, the focus is on the interface with reactor vessel BMI nozzle and refueling machine, the designing of the system as a whole and structural stiffness. Therefore, the approach consists upon looking at a problem in its entirety surrounding the BMI nozzle, reactor vessel and refueling machine. It requires the complete understanding on how and which part interacts with one another and how they can be combined into proper relationship to find a proper solution for the problem [1].

In this study, the SE methodology is used to design a nondestructive inspection system for reactor vessel bottom mounted Instrumentation (BMI) nozzles. The layout of the reactor vessel and internals including lower support structure (LSS) is shown in figure 2 [5]. The BMI nozzles at the bottom head of a nuclear RPV are one of such area for inspection.

Figure 2. APR 1400 Reactor vessel arrangement [5].

A system proposed in this study is composed of inspection probe assembly and delivery system that carries probe assembly for nondestructive inspection of BMI nozzles during regular fueling overhaul without removing of reactor internals. The proposed BMI nozzle inspection system will contribute for finding an early detection of

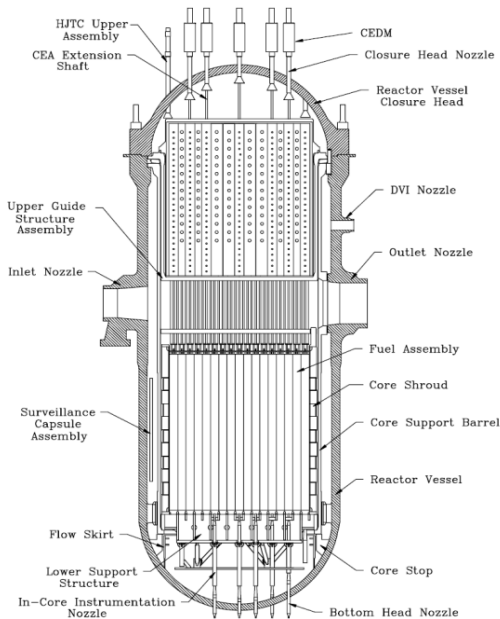

[Figure 2] APR 1400 Reactor vessel arrangement [5]

weld defects and lead to the prevention of leakage at the BMI nozzle weld region at an early stage of crack formation.

Using UT probe that is smaller than the BMI nozzle inner diameter and probe holder that can extend into Lower Support Plate of internals, the inspection and scan of BMI nozzle weld surface and volumetric defects can be found without removing the reactor internals. A 3D model of the inspection structure system was developed along with the RPV and internals to demonstrate the validity of the concept and simulate a virtual 3D environment for better visualization. This approach allows to verify the proposed BMI nozzle inspection system.

2. BMI Nozzle Experiences

Bottom mount instrumentation nozzles in bottom head of the nuclear RPV as shown in figure 3 are one of the pressure boundaries in reactor

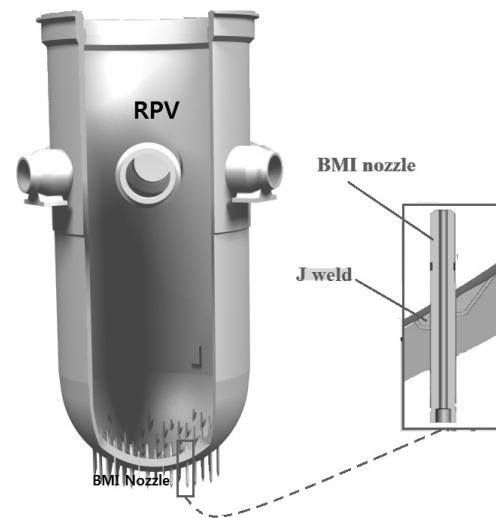

[Figure 3] 3D model of BMI nozzle of RPV

coolant system for inspection of weld cracking, also, the BMI nozzle welds form part of the primary pressure boundary and the weld filler material is of alloy 600 which is known to be susceptible to PWSCC.

Table 1 shows the status of PWR plant with respect to Alloy 600 nozzles in Korea. The RPV upper head of Kori Unit 1 was replaced in 2013, also the upper heads of Kori Unit 2 and Hanbit Unit 3, 4 are scheduled to be replaced. It is noted that BMI nozzle repair is very difficult due to the nature of access to the region. Thus PWSCC of BMI nozzles represents a potential risk.

2.1 South Texas project 1 (STP-1)

A reactor vessel bottom leak was discovered at South Texas Project (STP) Unit 1 during a routine inspection of the outside surface of RPV lower head BMI nozzle as part of a scheduled refueling outage in April 2003. The surprising discovery of boron from two nozzles were by visual inspection. During the inspection, a small

<Table 1> The Status of Alloy 600 Nozzles in PWRs in Korea [6]

No	Plant	Power MWe	Start operation	Upper Head Nozzle	BMI Nozzle	RCS Inlet/Outlet Nozzle
1	Kori 1	587	1978	Alloy 690	Alloy 600	Alloy 600
2	Kori 2	650	1983	Alloy 600	Alloy 600	Alloy 600
3	Kori 3	950	1985	Alloy 600	Alloy 600	Alloy 600
4	Kori 4	950	1986	Alloy 600	Alloy 600	Alloy 600
5	Shin Kori 1	1000	2011	Alloy 690	Alloy 690	Alloy 690
6	Shin Kori 2	1000	2011	Alloy 690	Alloy 690	Alloy 690
7	Shin Kori 3	1400	Under construction	Alloy 690	Alloy 690	Alloy 690
8	Shin Kori 4	1400	Under construction	Alloy 690	Alloy 690	Alloy 690
9	Shin Wolsong1	1000	2012	Alloy 690	Alloy 690	Alloy 690
10	Shin Wolsong1	1000	2015	Alloy 690	Alloy 690	Alloy 690
11	Hanbit 1	950	1986	Alloy 600	Alloy 600	Alloy 600
12	Hanbit 2	950	1987	Alloy 600	Alloy 600	Alloy 600
13	Hanbit 3	1000	1995	Alloy 600	Alloy 600	Alloy 690
14	Hanbit 4	1000	1996	Alloy 600	Alloy 600	Alloy 690
15	Hanbit 5	1000	2002	Alloy 600	Alloy 600	Alloy 690
16	Hanbit 6	1000	2002	Alloy 600	Alloy 600	Alloy 690
17	Hanul 1	950	1988	Alloy 600	Alloy 600	Alloy 690
18	Hanul 2	950	1989	Alloy 600	Alloy 600	Alloy 690
19	Hanul 3	1000	1998	Alloy 600	Alloy 600	Alloy 690
20	Hanul 4	1000	1999	Alloy 600	Alloy 600	Alloy 690
21	Hanul 5	1000	2004	Alloy 690	Alloy 690	Alloy 690
22	Hanul 6	1000	2005	Alloy 690	Alloy 690	Alloy 690
23	Shin Ulchin1	1400	Under construction	Alloy 690	Alloy 690	Alloy 690
24	Shin Ulchin2	1400	Under construction	Alloy 690	Alloy 690	Alloy 690
Total				13 Units	14 Units	6 Units

amount (153 mg) of residue was found on two of the BMI tubes that penetrate the underside of the vessel. Tests found boric acid and lithium-7 in the residue, confirming that it came from reactor coolant water. This was the first time leakage had occurred on the bottom of a RPV and figure 4 shows marks on the BMI nozzle. A thorough investigation was performed to find the cause and studied the repair method. The nozzles were repaired by half-nozzle replacement method in which bottom half of nozzles are removed and replaced by

new nozzles made of the more corrosion-resistant Alloy 690 material. The new half-nozzle is welded to RPV lower head to form pressure

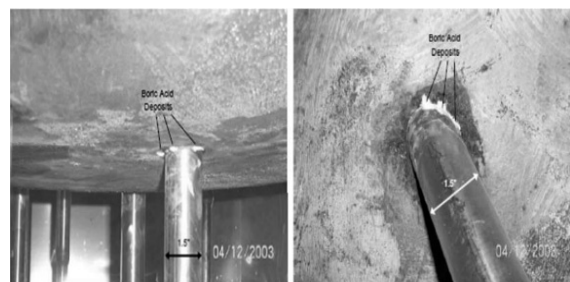

[Figure 4] Boric Acid Deposits Adjacent to BMI Nozzles #1, #46 [4]

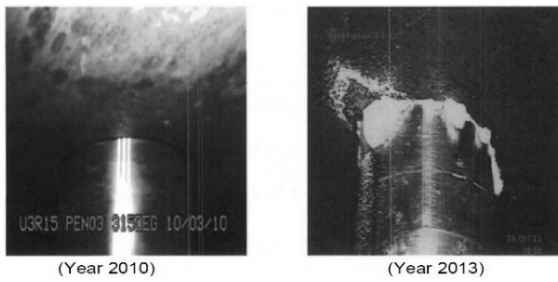

[Figure 5] BMI Nozzle No.3 PVNGS Unit 3 [8]

boundary [4–7].

2.2 PALO VERDE UNIT 3 (PVNGS–3)

On October 6, 2013, BMI nozzle number (#) 3 at Palo Verde Unit 3 (PVNGS–3) exhibited small white deposits around the annulus, figure 5 below indicate that the crack and subsequent leakage developed between inspections performed in 2010 (no leakage) and 2013 (with boric acid crystal indications), These were later determined to be boric acid. There are 61 bottom head penetrations (outside diameter of 3 inches and inside diameter of 0.75 inches). Nozzle attachment is via J–groove weld to Alloy 600 nozzle materials [8].

3. Concept development stage of system life cycle

The system life cycle shown in figure 6 is

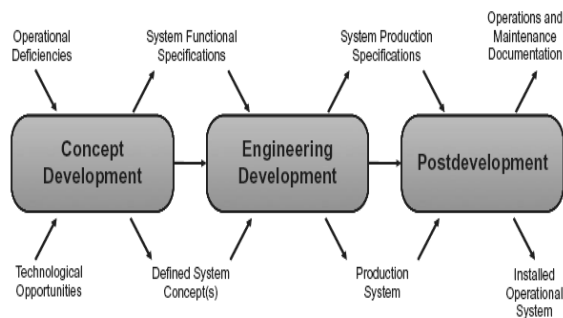

[Figure 6] System Life Cycle [10]

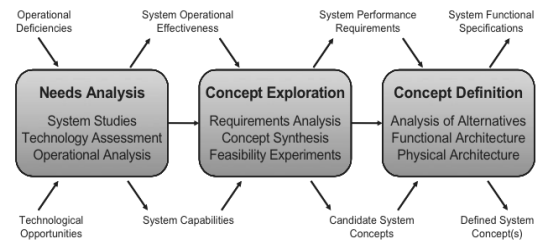

[Figure 7] Concept development stage [10]

one of the main concepts of SE approach [9]. A system’s life cycle usually consists of stages regulated by a set of management decisions that confirm the maturity of system so that the system can leave one stage and enter into another [10].

A life cycle model for a system identifies the major stages that the system goes through, from its conception to its retirement. The stages are culminated in decision gates, where the key stakeholders decide whether to proceed into the next stage, to remain in the current stage, or to terminate or re–scope related projects. The initial conception begins with a set of stakeholders agreeing to the need for a system and exploring whether a new system can be developed, in which the life cycle benefits are worth the investments in the life cycle costs.

In this paper the concept development stage of system life cycle is introduced. The concept development stage divided into three phases: Needs Analysis, concept Exploration, and concept Definition as shown in figure 7.

3.1 Needs Analysis

The need analysis is a phase that is responsible for the determination of the need for a new system, need analysis defines and validates the need for a new system, demonstrates its feasibility, and defines system operational re–

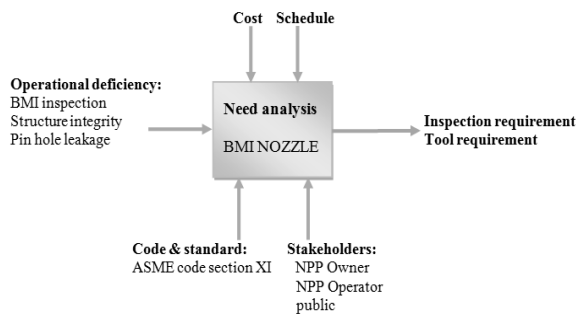

[Figure 8] IDEF0 Level1-1 diagram for need analysis

quirements this is done by using integrated definition function model IDEF0 to show the activities involved in the need analysis phase as shown in figure 8 [1]. The aim of the new design is to achieve inspection of BMI nozzle to enhance safety and reliability. There is a need for a system to achieve internal inspection of BMI during refueling time without removing the reactor vessel internals. The perception of a deficiency in a current inspection system design to meet operational needs.

The BMI nozzle is submerged in water; the BMI inspection needs to be done in submerged environment. Also the reactor vessel inside environment is highly radioactive, so a remote inspection operation needed.

3.2 Concept Exploration

The Concept Exploration stage searches feasible concepts and defines functional performance requirements. In this phase, the review and research on the current existing technology related to inspection and mitigation of cracks in BMI. Different areas were also studied to provide a better understanding and solve the problems of current BMI inspection tools and methods. The current BMI inspection tools is introduced and 3D model of LSS is modeled

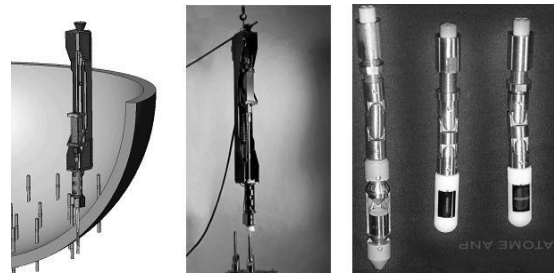

[Figure 9] (Left & center) BMN nozzle inspection tool (right) TOFD circumferential, axial, and zero degree probes [11]

and introduced in this stage. The output of this stage is concept exploration of BMI nozzle inspection.

3.2.1 Current BMI nozzle inspection tools

AREVA NDE Solutions introduced an inspection system to ease the J-weld inspection challenge including improved underwater remote manual scanner as shown in figure 9 for bottom mount nozzle (BMN) J-weld ET examination. In 2003, AREVA developed a remote manual scanner for detecting BMN weld region crack indications. This manipulator has been improved and upgraded with better video and better surface tracking and articulation of the ET array probe, but this inspection system required to remove all reactor internals [11].

Figure 9. (Left & center) BMN nozzle inspection tool (right) TOFD circumferential, axial, and zero degree probes [11].

KPS of Korea (KEPCO KPS) carried out BMI nozzle inspections of Westinghouse-type plants, Kori Unit 1 in 2006, Ulchin Unit 2 in 2007, and Kori Unit 3 in 2008. The first inspection of the OPR-1000 plant was carried out on May 2011 at Hanbit Unit 3. KPS developed an inspection technique of the OPR-1000 plant [12]. The in-spection was performed as part of ten-year

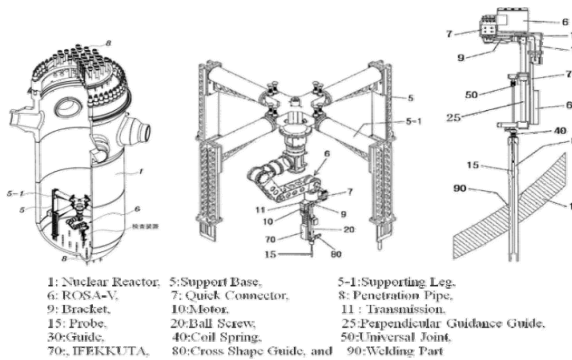

[Figure 10] ROSA-V6 [13]

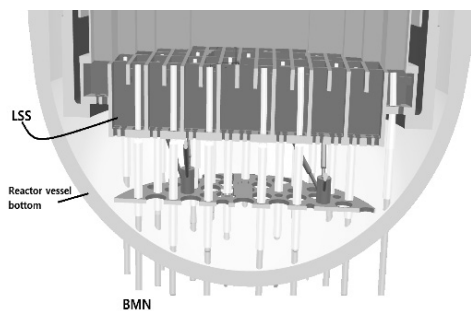

[Figure 11] 3D Model of Bottom head of RPV

reactor vessel ISI the tools used for inspection are shown in figure 10 and are based on ROSA-V6 manipulator [13].

The LSS of RPV block the lower part of RPV, as shown in figure 11 a 3D model of the RV with internals. Lower part of RPV blocked by LSS and LSS welded in CSB, this is the reason why they remove the reactor vessel internals to inspect BMI nozzle. In this study LSS studied carefully to find the way and the path to reach to the BMI nozzle without removing RPV internals.

3.2.2 LSS and ICI nozzle assembly

The LSS is made up of a short cylindrical section enclosing an assemblage of grid beams arranged in eggcrate fashion. The outer ends of these beams are welded to the cylinder. Fuel assembly locating pins are attached to the

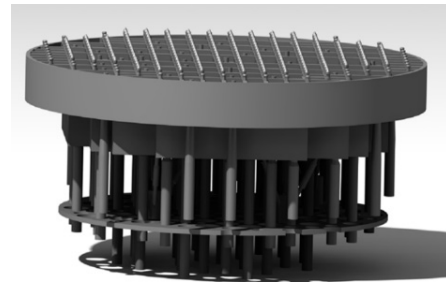

[Figure 12] 3D Model of the LSS and ICI nozzle

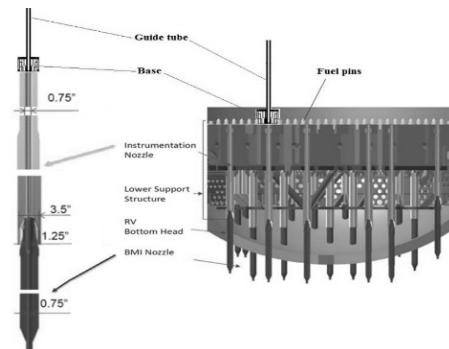

[Figure 13] Concept exploration of BMI inspections

beams [14]. The 3D Model of The lower support structure and ICI nozzle assembly is shown in figure 12 [15].

The LSS block the reactor vessel bottom and can't reach to BMI, but the ICI nozzle is aligned with BMI, so the concept is design a system has guide tube aligned with ICI which aligned with BMI. And the new system base has a base almost similar with fuel assembly base to prove the location on LSS by fuel pins which attached to the LSS beams. Figure 13 shows the RV bottom and the sketch of new design idea.

3.3 Concept Definition

In this phase, an alternative concept is introduced that can be applied and used for the inspection of BMI nozzle weld. To do this, a systematic analysis, such as current researches and different methodologies currently being used

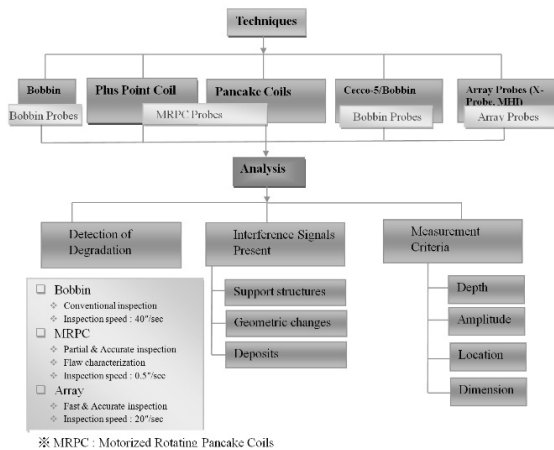

[Figure 14] Inspection technique general

to mitigate cracking are shown in figure 14. Also, it takes into account the safety analysis for the methodology implementation, and interfaces with BMI nozzle and other surroundings. In this stage of concept development stage the probe and monitoring camera is introduced.

3.3.1 Probe technology for BMI inspection

DEKRA Industrial AB introduced a mechanized inspection system that can inspect RPV Shell Welds, Nozzle Welds and BMI Welds as well as visual inspection of Radial Support Welds in all three PWRs at Ringhals (units 2, 3, and 4). The BMIs was inspected with a combination of pulse echo, TOFD (time of flight diffraction) and ET (eddy current test) probes, manufactured by DEKRA as shown in figure 15 [16].

The tubing inspection probe IRIS UT (Internal Rotary Inspection System) shown in figure 16 operates in pulse-echo mode to measure defect, wall thickness, and material loss orientation within the range of 0.625 inch to 3-inch depth.

The probe consists of an ultrasonic transducer firing in the tube axial direction. A mirror mounted on a water propelled turbine deflects the ultrasonic beam to get a normal incidence

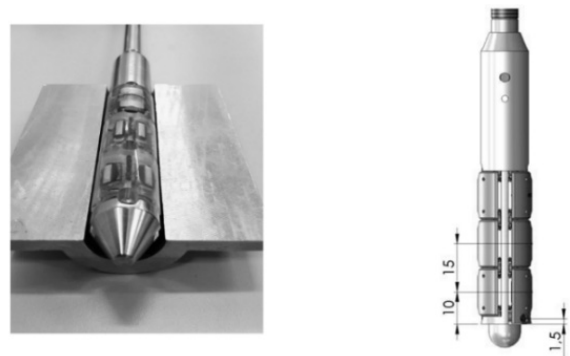

[Figure 15] BMI dimensions and DEKRA BMI probe with, 0° TRL, 2x TOFD and ET [16]

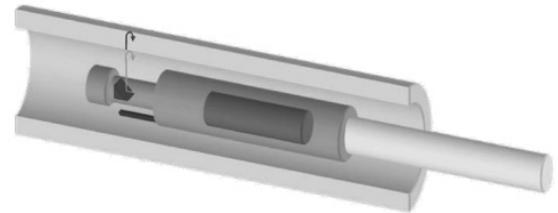

[Figure 16] Tubing inspection probe [17]



[Figure 17] Centering device (TUC)

wave on the tube internal wall. A complete IRIS probe includes the cable, a centering unit, a turbine, and a transducer. The IRIS Kit consists of the followings [17].

- Four centering device as in figure 17 (with two kinds of sizes)
- Two turbines sizes: 12 and 17 mm
- Four types of transducers available,
- Two standard cable lengths as in figure 18: 45 ft. and 90 ft.,
- Stainless steel flood tube adapter,
- Pump, filter, and regulator unit, and
- Circumferential crack detection turbine.

WesDyne Sweden produces ultrasonic (UT) and Eddy Current (ET) probes and they have



[Figure 18] Probe cables

BMI probe
 Ø7.5 mm and larger
 0° for detection
 ET-X for detection
 TOFD for sizing (axial)
 TOFD for sizing (circumferential)
 45° for detection



[Figure 19] BMI probe [18]

small bore probe that can be used for our purpose. The BMI probe for inspection of bottom instrumentation nozzles in PWR can be made to fit inside nozzles from Ø7.5 mm and up. The probes can be several different transducers, such as ET, TOFD and UT 45" 0" as in figure 19 [18].

3.3.2 Monitoring inspection process camera

REMOTE MONITORING (MICROCAM): The MicroCam offers mix of color imaging capabilities, small size, lighting, radiation tolerance, and economy. For difficult and hard to reach areas, the MicroCam can be attached to an extendable arm. The MicroCam is also environmentally sealed and has an ultra-wide vibration spec, rated to operate underwater to depths of 200 feet with an incredibly high resistance to impact. Figure 20 shows MicroCam dimensions, and Table 2 shows technical specifications [19].

By the end of concept definition stage the probe, connector and monitoring camera for inspection process is introduced. The probe will be inserted through guide tube till BMI nozzle

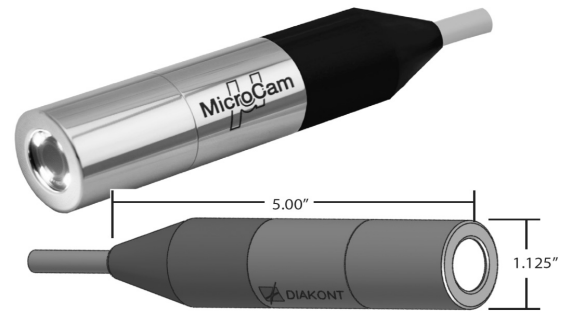

[Figure 20] MicroCam dimensions [19]

<Table 2> MicroCam technical specifications [19]

Camera Sensor	Color APS
Resolution	420 H-TVL
Minimum object distance	2"
Sensitivity	0.025 lux (50 IRE) F1.2 3200°K
Field of View (diagonal)	88° in air 63° in water
Environment	Water, air
Maximum Operating Temperature	145°F
Lights	Integral, LED
Housing	316 Stainless Steel
Length	5.00"
Diameter	1.125"
Protection	200' submersible
Environmental	IP68
Cumulative Dose	50,000 Rads
Maximum Dose Rate	100,000 Rads/hr

and camera will used to monitor inspection process.

A proposed system in this study are composed of inspection probe assembly and delivery system that carry probe assembly enables nondestructive inspection of BMI nozzles during regular fueling overhaul without removing of reactor internals. The proposed BMI nozzle inspection systems will contribute to finding an early detection of weld defects and lead to prevention of leakage at the BMI nozzle weld region at an early stage of crack formation. The proposed BMI nozzle

inspection systems will contribute to producing regular trend data (history), based on this data, the BMI nozzle management program can be establishing.

Using UT probe that is smaller than the BMI nozzle inner diameter and probe holder that can extend into Lower Support Plate of internals, the inspection and scan of BMI nozzle weld surface and volumetric defects can be found without removing the reactor internals. A 3D model of the inspection systems was developed along with the RV and internals to demonstrate the validity of the concept and simulate a virtual 3D environment for better visualization. This approach allows to verify the proposed BMI nozzle inspection systems.

4. Conceptual design of BMI inspection system

4.1 Regulatory guide and standards requirement

For operating NPPs, in service inspection (ISI) program is required and the examination of class 1 components such as the reactor coolant pressure boundary components and supports is very important. The principles and procedures are defined in the ASME Boiler and Pressure Vessel Code, Section XI. Specific Code Editions and addenda. These ASME Section XI codes are referred by 10 CFR 50.55a, hence any NPP's following 10 CFR 50.55a shall observe the rules and procedures set by ASME Sec. XI. Figure 21 shows ASME code section III, and ASME code section XI application.

The Owner's responsibilities include [20]:

- a) Provision of access in the design and arrangement of the plant to conduct the examination and tests;

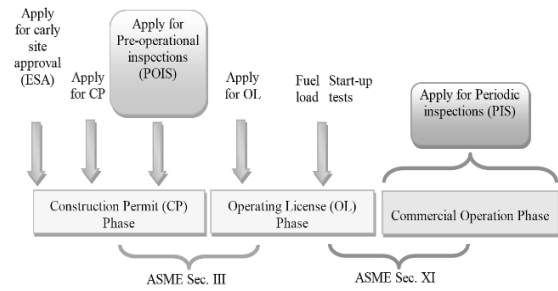

[Figure 21] ASME code section III and section XI

- b) Development of plans and schedules, including detailed examination and testing procedures;
- c) Conduct of the program of examination and tests, system leakage and hydro-static pressure tests; and
- d) Recording the examinations and tests results, including corrective actions required and the actions taken.

4.2 System requirement

To inspect BMI nozzle every refueling outage the system requires to introduce a tool can access and reach to BMI nozzle without removing RV internals, figure 22 shows the RV with

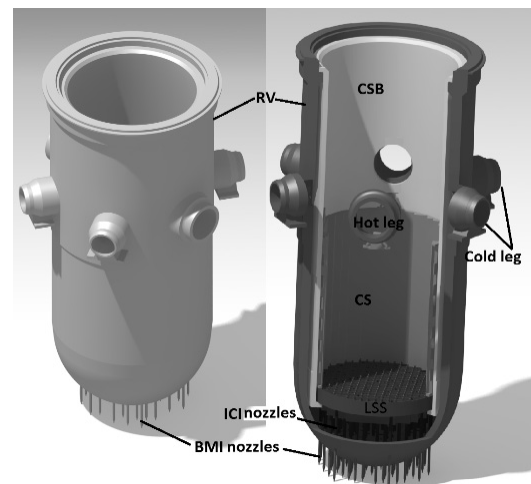

[Figure 22] 3D model of RV, CSB, CS and LSS [15]

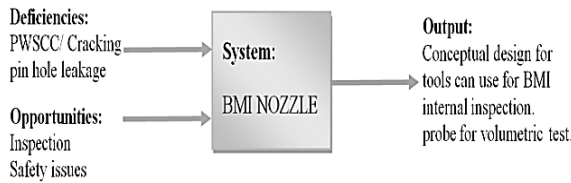

[Figure 23] BMI Input / Output Diagram

internal.

Since the BMI nozzle is submerged in water, the BMI inspection needs to be done in submerged environment. Also the reactor vessel inside environment is highly radioactive, a remote inspection operation concept is adapted to protect operator from radiation. Equipment to protect operator to work under-water would require much more complicated equipment and operation, and it also would require much more complicated procedure to protect operators. Hence, remote operation is more economical option in this case.

By applying the SE approach on the BMI nozzle, it is possible to find a solution to a problem in a more efficient and easier way to develop the design and implementation of the BMI nozzle inspection system. When analyzing the deficiencies in the BMI nozzles, and combining those with opportunities, the output will be the methodology for inspection as shown in figure 23.

The system requirements are applied to the concept development of the BMI nozzle inspection system. According to SE approach, the inputs can be defined as either deficiencies or opportunities. By deficiencies we can list PWSCC of BMI nozzle welds, Cracking (in a more general way), BMI nozzle pin hole leakage, difficulty of access to the BMI nozzle inside without removing reactor internals, highly radioactive surroundings

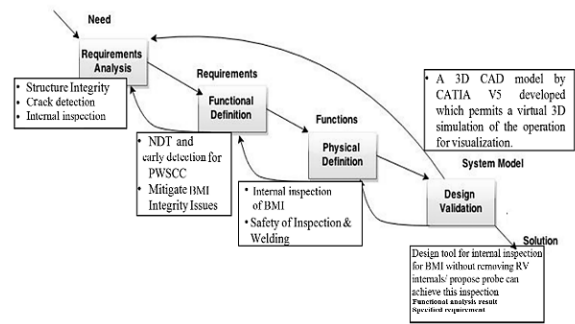

[Figure 24] SE Method Top-Level Flow Diagram

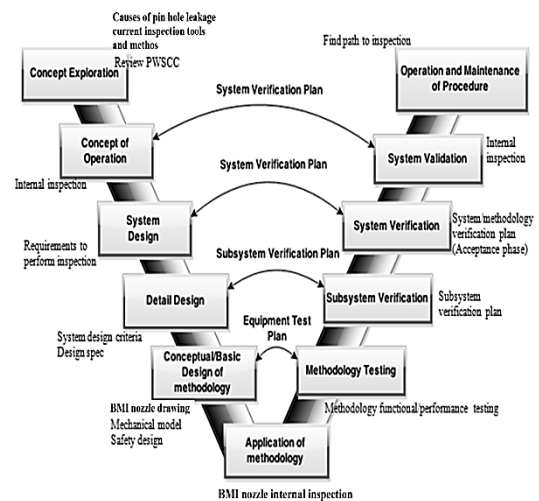

[Figure 25] V-Model for BMI inspection

and underwater environments, etc. The opportunities are to provide a methodology for internal inspection of the BMI nozzles and prevention of leak from BMI nozzle, this will lead to reduce inspection period to become every refueling outage.

Top-level flow diagram is shown in figure 24 [1], and the V-Model for BMI nozzle inspection is shown in figure 25 [10].

4.3 BMI nozzle inspection system development

In order to make such frequent inspection feasible, a special device is necessary to do the job conveniently. For this objective, BMI Inspection Device was conceptualized.

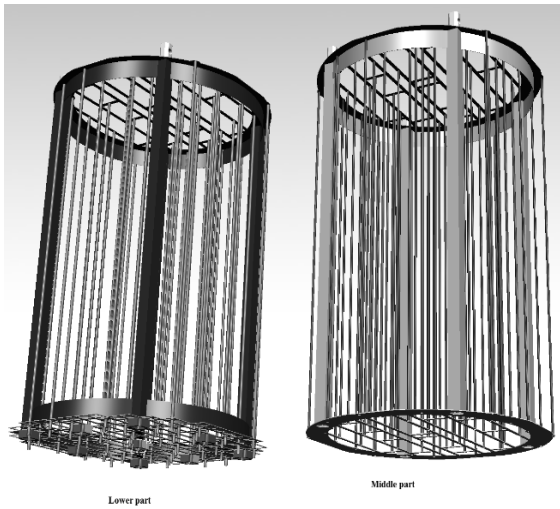

[Figure 26] Lower part and middle part of BMI inspection structure [15].

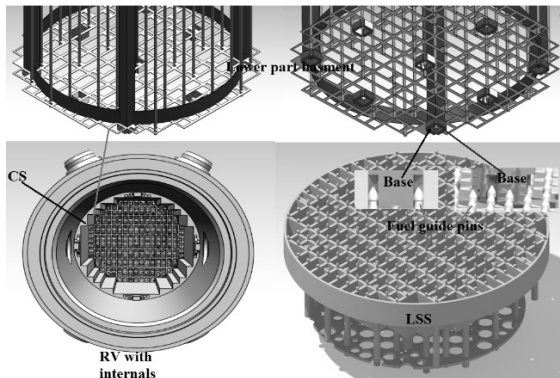

[Figure 27] Lower part basement with LSS and CS [15]

The BMI inspection structure consist of three parts, lower part fit and fix on LSS and has guide tube align with ICI, and middle part and upper part identical and has a guide tube aligned with lower part tube. Figure 26 shows 3D drawing of lower part and middle part.

The lower part basement of inspection structure system consist of two basement level as shown in figure 27, the first one which is in bottom take the shape of fuel assembly lower base part to fit with LSS and positioned on LSS and aligned with ICI by using fuel guide pins. The second basement level of lower part basement

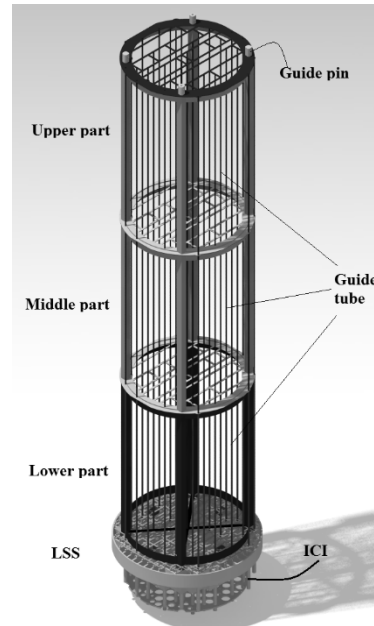

[Figure 28] 3D model of the inspection structure on LSS

is take the CS pattern shape to take the lateral alignments.

Figure 28 shows the 3D assembly of the inspection tool, the lower part is installed on LSS, middle part installed on the top of lower part which has a four guide pins to positioned middle part, and upper part installed on the top of middle part which has a four guide pins to positioned upper part. the lower part of the inspection tool is installed on LSS plate and positioned and aligned with ICI by using fuel assembly guide pins, as a result of this it is not necessary to remove RPV internals.

The concept of the BMI Inspection structure was shown in 3D rendering as shown in figure 29. The installation process consists of the probe adapter that can fit and fixed on the lower support structure, and after placing the probe adapter we can insert the probe through the (in core instrument) ICI guide tube until it reaches BMI nozzle weld region. The easy installation and operation would meet the re-

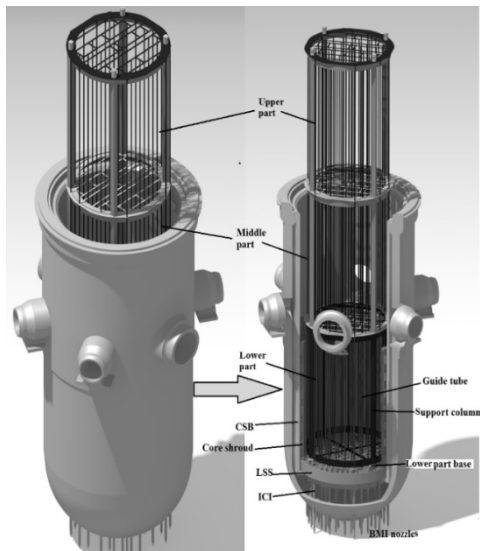

[Figure 29] 3-D model for nozzle inspection tool in reactor vessel

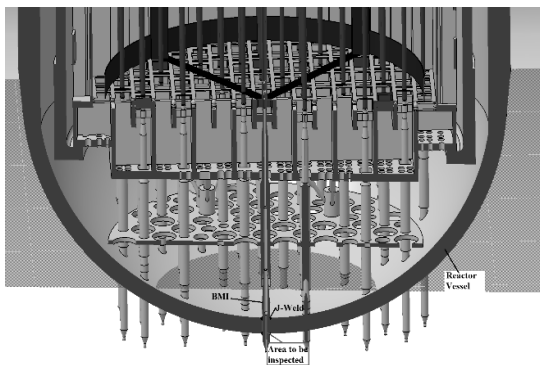

[Figure 30] Area to be inspected of BMI.

quirement of BMI nozzle inspection during the refueling outage and also reduces the number of inspection personnel. The 3D graphic implementation of conceptual design of the BMI inspection nozzle was successfully modeled by 3D CAD software as shown in figure 29. A zoom in of reactor BMI nozzle area is shown in figure 30.

The BMI Inspection structure is assembled as follows,

1. Using polar crane insert Lower part that fits into with the desired position of LSS in RV.

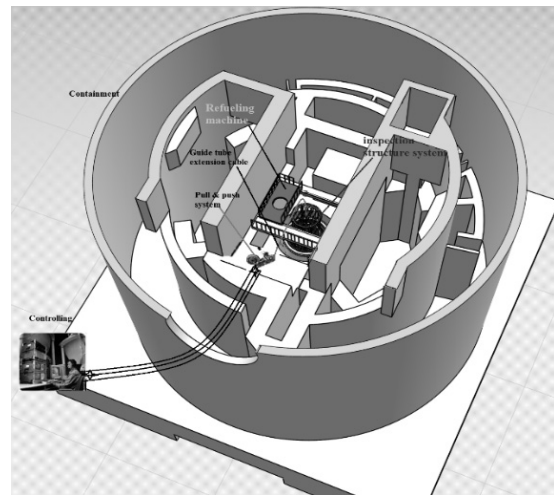

[Figure 31] BMI nozzle inspection system through containment penetration

2. Using polar crane insert Middle part which has four hole to align with Lower part which has four guide poles.
3. Using polar crane insert Upper part which has four hole to align with middle part which has four guide poles.

The conceptual diagram of BMI inspection structure system inside containment is given in figure 31, which illustrate containment, refueling machine, RV, and new conceptual design in 3D.

4.4 Design Verification.

Verification is the process to check and test if the proposed design meets the requirements. Verification can be conducted via analysis, inspection, peer checking and/or personal judgment of the results. In this study, 3D virtual realization was used. The Vertical cross section was modeled as shown in figure 32 to verify the alignment guide tube with ICI tube.

Using generative structural analysis in CATIA v5 [19], the structural integrity was investigated. The figure 33 shows Lower Boom static struc-

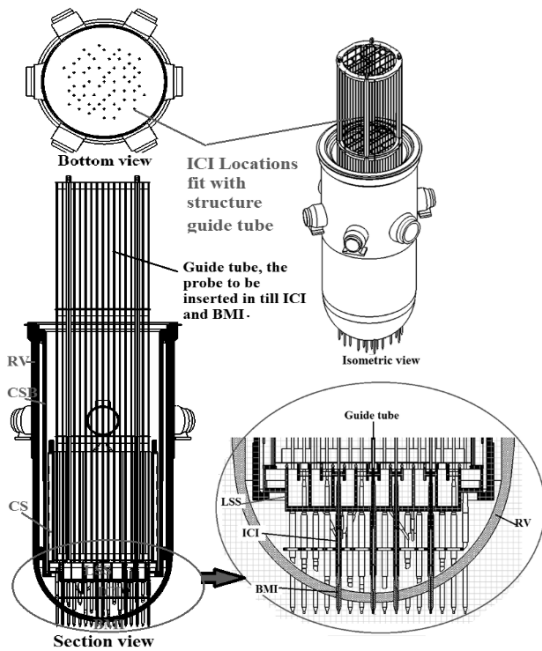

[Figure 32] 2D Model of RV and inspection tool

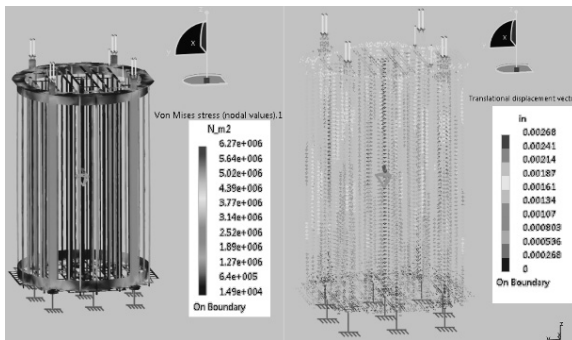

[Figure 33] Left: Von Mises stress of lower part, and Right Translational displacement of lower part [15]

tural analysis results where equivalent stress and total deformations. The structural analysis of Middle Boom and Upper Boom are the same and shown in figure 34 for equivalent stress and total deformations.

Using CATIA v5 digital mockup navigator environment a 3D model for virtual reality verification and design verification to meet the requirement as shown in figure 35.

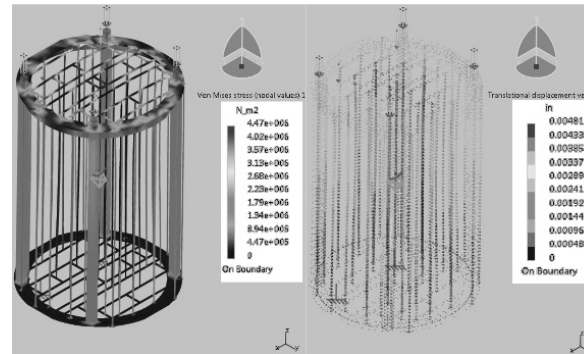

[Figure 34] Left: Von Mises stress of Middle part, and Right Translational displacement of Middle part.

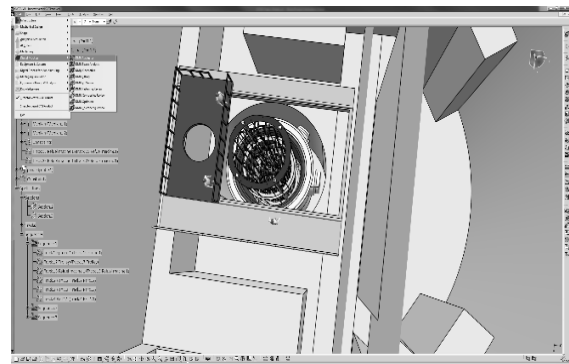

[Figure 35] 3D Model for virtual reality verification [15]

5. Conclusions

Using SE approach, BMI nozzle inspection system was developed to enable nondestructive inspection of BMI nozzles during regular refueling outage. The proposed BMI nozzle inspection system can make it possible to find an early detection of BMI nozzle weld defects and lead to prevention of leakage. The design objective was to do inspection of BMI nozzle in-situ, i.e. without removing reactor internals. A conceptual design was successfully presented and shown by 3D virtual simulation. A search of UT probe that is fit inside of BMI nozzle was also carried out and reflected in the design of the BMI inspection system.

In this paper concept for the BMI nozzle

inspection system was developed with following constraints or requirements.

1. Inspect BMI nozzle inside surface without removing the reactor internals
2. Remote operation capability to operate underwater and highly radioactive environment
3. Ease of operation during refueling outage

The future work is the fabrication of prototype BMI nozzle inspection system.

Acknowledgement

This work was supported by the 2015 Research fund of the KEPCO International Nuclear Graduate School (KINGS), Republic of Korea. The authors would like to express appreciation toward KINGS.

References

1. Kossiakoff, A. and W.N. Sweet, "Systems Engineering: Principles and Practice," Wiley-Interscience, Hoboken, NJ, pp. 69-109, (2011).
2. USNRC BULLETIN 2003-02, "Leakage from RPV lower head penetration and reactor coolant pressure boundary integrity," Aug. 21, 2003.
3. Steven Thomas, "PWSCC of Bottom Mount Instrument Nozzles at South Texas Project," ICONE12-49521, 12th International Conference on Nuclear Engineering, Arlington, Veriginia, USA, April 25-29, 2004.
4. Christine King, "Materials Reliability Program: South Texas Project Unit 1 Bottom Mounted Instrumentation Nozzles (#1and #46) Analysis Reports and Related Documentation (MRP-102)," 1009309, November 2003.
5. KHNP, "APR1400 Standard Safety Analysis Report: Reactor coolant system and connected systems" chapter 5, Korea Hydro and Nuclear Power Co. Ltd., (2002).
6. Baik Jun Ki, Yang Jin Seok, and R. M. Field (2014), "PWSCC Mitigation for life extension of reactor vessel nozzles," Material selection in NPP design project report, Course E14004, KINGS, and South Korea.
7. STP's First-of-a-Kind Leakage Repair, Nuclear News, <http://www2.ans.org/pubs/magazines/nn/docs/2004-10-2.pdf>, pp. 32-34, 2004.
8. Palo Verde Nuclear Generating Station (PVNGS) Unit 3, Docket No. STN 50-530, License No. NPF 74, Licensee Event Report 2013-001-00, 2013.
9. Blanchard, B.S., and W.J. Fabrycky, "Systems Engineering and Analysis," 5th ed. Prentice-Hall International series in Industrial and Systems Engineering. Englewood Cliffs, NJ, USA: Prentice-Hall, pp. 142-161, (February 2010).
10. INCOSE, Systems Engineering Handbook, version 3.2.2., INCOSE-TP-2003-002-03.2.2., pp. 61-218, (October 2011).
11. S.W.Glass, B, Everett, et Al, "Advances in J-weld Inspection for RPV head and RPV Bottom Mount Nozzles," 9th International Conference on NDE in Relation to Structural Integrity for Nuclear and Pressurized Components, May22, 2012- Seattle, Washington, USA, 2012.
12. E. Doh, Y. Kim, J. Kim, and C. Song, "inspection of bottom mounted instrumentation nozzles in Korea," KEPCO Plant Service and Engineering Co. Ltd., Korea, p. 590.

13. Min-Su Park, Sang-Hoon Choi, Eui-Soon Doh, Nag-Jeam Kim, Dong-Il Kim, and Yoon-Won Kim, "inspection apparatus for reactor bottom mounted instrumentation nozzle," Patent US 20080240331 A1, Oct. 2, 2008.
14. KHNP, "APR1400 Standard Safety Analysis Report: Design of Structures, Components, Equipment, and Systems," chapter 3, Korea Hydro and Nuclear Power Co. Ltd., (2002).
15. CATIA version 5-6. (2012). "User guide, training and tutorials, and help manual," CATIA, Dassault Systems, 2012.
16. Mats Wendel and Torbjörn Sjö, DEKRA Industrial, Sweden, "development of new manipulators for PWR and VVER vessel inspection," <http://www.ndt.net/article/jrc-nde2012/papers/89.pdf>. pp. 538-539, 2011.
17. Eddyfi, "tubing inspection probe catalog," March 2015, www.eddyfi.com
18. WESDYNE web site, "A Westinghouse NDE Company," 2015, www.wesdyne.com.
19. USA, Diakont Advanced Technologies, "MicroCam, specification sheet," 2015 <http://www.diakont.com/>
20. ASME Boiler and Pressure Vessel Code, "Rules for In-service Inspection of Nuclear Power Plant Components," Section XI, IWA-1400, pp.2, (2010).