

A Study on the Analysis vibration of fluid flow in ECV

WANGWENHAI and Haeng Muk Cho[†]

Division of Mechanical & Automotive Engineering, Kongju National University College of Engineering

(Received 13 March 2015, Revised 27 May 2015, Accepted 29 May 2015)

Abstract

Pipe vibration caused great threat to the safety in production. Strong pipeline vibration will line accessories, especially the joints and pipe fittings etc. pipe joints loosening and rupture, causing serious accidents. By the action of the compressor constant fluid flow within the pipe, this process produces pulsating fluid flow may cause vibration of the pipe, thereby reducing the efficiency of the pipeline, structural vibration induced fatigue, thereby resulting in even piping structural damage. This paper studies on the vibration problems caused by fluid, by analyzing the causes of pipeline vibration and factors affecting pipeline vibrations, FEM (Finite Element Method) analysis of modal and enforced vibration.

Key words : Electromagnetic Control Valve (ECV), Vibration, Modal analysis, CFD simulation

1. Introduction

Since the fluid in the ECV is a continuous elasto-meric, so that the fluid itself has natural frequency, when the excitation frequency and the fluid compressor itself movement close to the natural frequency when the resonance will occur, this time varying the amplitude very large, so the compressor is running, you should try to avoid the occurrence of fluid resonance [1].

ECV is used in automotive air-conditioning control system. Because of ECV needs to control the pressure at different pressure ports locate on the valve body; the design therefore need to be very precise and accurate. Generally, the tolerance for each component of ECV is $\pm 0.02\text{mm}$ to $\pm 0.05\text{mm}$, whereas some of the components associated with the leakage

performance are assembled within a tolerance of $\pm 0.002\text{mm}$ which is definitely a challenging issue to obtain [2]. Because of ECV needs to control the pressure at different pressure ports locate on the valve body; the design therefore need to be very precise and accurate. By the action of the compressor constant fluid flow within the pipe, this process produces pulsating fluid flow may cause vibration of the pipe, thereby reducing the efficiency of the pipeline, structural vibration induced fatigue, thereby resulting in even piping structural damage.

First, calculate the valve vibration of the valve to avoid resonance, fluid resonance occurs in the fluid piping system excitation frequency coincides with the natural frequency of the time, so it should advance to the natural frequency of the fluid piping system calculated, avoiding fluid resonance and vibration abatement pipelines have significance.

This paper complete geometric modeling by computer, a finite element model of piping systems, piping systems with software modal analysis to calculate the natural vibration frequency. Simultaneous analysis to

[†]To whom corresponding should be addressed.
Division of Mechanical and Automotive Engineering, Kongju National University (KNU)2 75, Budae-dong, Cheonan-si, Chungcheongnam-do 330-717, South Korea
Tel : 041-521-9287 E-mail : hmcho@kongju.ac.kr

calculate the distribution of fluid flow within the pipeline pressure and flow rate of the fluid and the natural frequency of vibration of the fluid column.

2. Governing equations

Inside of pipes conveying fluid pressure pulse is an extremely complex phenomenon, its research and development with the improvement of the calculation method of computer application technology, experienced from the simple to the complex, rough to the exact process. From ignore damping to calculate damping; from limited to small fluctuations in the limited amplitude fluctuations, as well as the thermal exchange, factors to be considered, the more, the more can be close to the actual process, however, deal with solving the corresponding mathematical models and mathematical equations are more complex .

Initiation of a main pipe vibration is caused by the pressure caused by the intermittent pressure pulsation caused by the fluid, since the gap pressure, pressure in the pipeline in the vertical average value of the pulsation, called pressure pulsation. In the bent portion of the valve, the diameter of the site or by changes in the control valve, the pressure pulsation will produce a corresponding change over time of the exciting force. It is these exciting force, vibration excitation occurs valve.

Typical pressure pulsation equation:

$$c^2 \frac{\partial^2 p}{\partial x^2} = \frac{\partial^2 p}{\partial t^2} \quad (1)$$

c is the acoustic velocity, p is the instantaneous pressure, t is time, x is the displacement.

Wherein K_f the fluid bulk modulus, ρ is the fluid density,

$$c^2 = \frac{K_f}{\rho} \quad (2)$$

Sticky liquid and compressible fluid motion uni-

form pressure distribution along the cross-section, consider the impact of friction between the liquid and the wall; according to the equations of motion of the liquid was Alembert principle.

$$\frac{\partial p}{\partial x} dxS + \rho S dx \frac{dV}{dt} + \tau \pi dx = 0 \quad (3)$$

d is the diameter, V is the speed of movement of the medium, τ is the pipe wall friction generated per unit area, λ is the Resistance factor, S is the Pipe cross-sectional area.

Valve liquid natural frequency of vibration analysis:

If the excitation frequency is f_j , liquid natural frequency is f , Then when $f_j = f$, liquid resonance occurs, but if the resonance amplitude is understood to considerable, then the resonance should not be understood as only at one point, and considered to be within the vicinity of the frequency, this area is called the resonance region[3]

3. Simulation and results

There are considerable differences between the behavior of the smallest and largest particles within our range of interest, roughly from molecular sizes up to 10^3 microns. The smaller particles closely follow the motion of the surrounding gas and may remain airborne almost indefinitely, whilst the larger particles have an appreciable acceleration under gravity and are relatively easy to precipitate. Nevertheless, large grains of dust are transported for many miles under favorable atmospheric conditions, fig. 3.

Modal analysis process consists of four main steps:

(1) Modeling

In this step, specify a project name and title, to define the element type, material properties and geometry.

(2) Load and solving

In this step, define the type of analysis and analysis options, applied load, load phase option is specified, and the natural frequency of the finite element solution.

(3) Extended mode

Observing modes, spectral analysis

(4) observation results

The results of modal analysis results are written to a file, analyze the results.

The results of fluid in the valve are:

Figure 1 fluid flow from the valve velocity maps and Figure 2 the fluid relative pressure inside the valve distribution can be seen, the maximum fluid pressure occurs in the corner of the valve, the valve fluid inlet section of the turbulent kinetic energy is small, at the first corner turbulent kinetic energy increases. In the middle of the turbulent kinetic energy maximum. Further, in the two corner bend of the fluid flow rate is relatively high, the bend at a relatively low average flow rate. This is because the

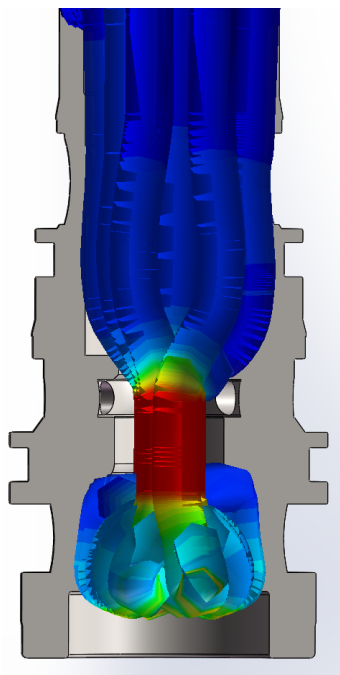

Fig. 1. valve fluid velocity

fluid passing through the corners of the sudden change in flow direction, the direct impact of the fluid pressure generating additional force in the

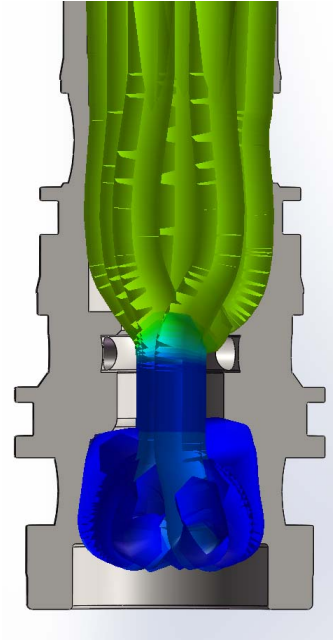

Fig. 2. Relative pressure of fluid in the valve

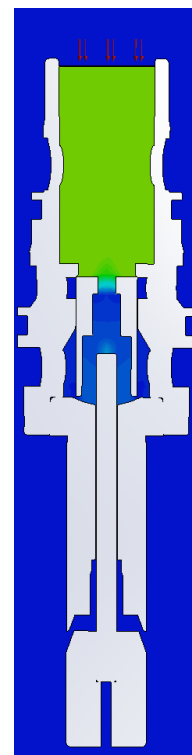

Fig. 3. static pressure in valve

corner, while changing the direction of the velocity due to loss of energy, thereby causing the above phenomenon.

From the finite element analysis can be seen, the fluid passes through the curved portion, due to mutation of the fluid pressure and velocity direction, the valve will have a great additional force, if the fluid is pulsed, excitation force will be generated on the pipe causing valve vibration.

To simplify the simulation, solid curved ends of the valve fixed constraints that U_x , U_y , U_z are zero, the fluid is air, with 1 m/s speed (low-end) into the outlet end of the tube is zero pressure.

Figure 5 and 6 is the fluid movement into the front of the results obtained to the frequency analysis inside.

Figure 5 can be seen, where large amplitude occurs mainly on the outside, but also in the turning point



Fig. 4. relative pressure distribution in the valve



Fig. 5. Amplitude results of the model 4

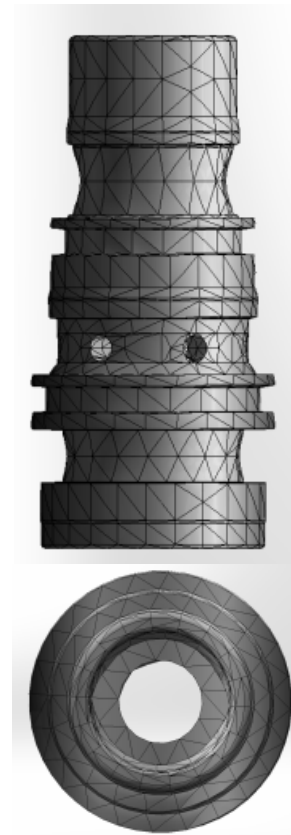

Fig. 6. Amplitude results of the model 5

Table. 1. model frequency

Model No.:	(rad/s)	(Hz)	Period (s)
1	0	0	1.00E+32
2	0	0	1.00E+32
3	0.003534	0.000562	1778.2
4	0.003924	0.000624	1601.3
5	0.004399	0.0007	1428.3

of the larger conduit and the fluid pressure in places. This is because the velocity and direction of the fluid is changed, the energy loss of the fluid to generate vibrations.

(Hz) Radians / sec and Hertz listed resonant frequency, period Listed in seconds resonance cycle. As can be seen from the table 1 the fluid energy of the excited mainly in 3, 4, 5, and the high frequency disturbances caused by the movement of the valve, there is little impact on the pipeline pressure pulsation.

Fluid flow within the valve increases, the natural frequency of the valve is lowered, when the flow rate reaches a critical velocity, valve instability occurs, but analysis shows that the duct velocity instability occurs almost impossible in practical engineering, compared with the critical velocity in the valve fluid flow rate is very small, thus the conclusion shows that, in calculating the valve vibration, we need only consider the impact of the additional mass of the fluid was brought without having to consider the impact of the natural frequency of the flow rate of the valve.

4. Conclusions

Because of the presence of the area difference, that is the additional force that is the presence of the exciting force, will cause vibration of the valve. Therefore, the ECV fluid pressure pulsation exists, there will be exciting force generated and cause valve vibration. Therefore crucial not only to design the valve to avoid resonance, but also in the valve so that the

pressure pulsation as small as possible, elbows, valve lead, tapered pipe should be used as little as possible, and a small selection of produce exciting force structure as possible.

In this paper, the method for calculating and measuring the natural frequency of the fluid pipeline has been studied to solve the above study the natural frequency of the fluid in the pipe calculation and measurement problems. Vibration abatement works on pipeline issues play a guiding role. With some supporting the ends of valve conveying fluid articulated as a model to establish free vibration mathematical model, and the effect of the fluid within the possession of its natural frequency. we describes the application of finite element software valve modal analysis methods and steps to establish its finite element model, finite element calculation, the pipeline system modal frequencies and mode shapes.

Acknowledgment

This research was supported by Basic Science Research Program through the National Research Foundation of Korea(NRF) funded by the Ministry of Education(2014K2A1C2074194)

References

1. Y. J. Lee, G. H. Lee and B. E. Lim, "Design for Improving the Performance of a Control Valve in a Variable Compressor", 4th International Conference on Sustainable Automotive Technologies, RMIT University, Melbourne, Australia (2012), pp 343~348.
2. Md. Iqbal Mahmud, Yong Jun Yoon and Haeng Muk Cho, "Leakage Analysis of ECV in Variable Displacement Swash Plate Type Compressor", International Journal of Applied Engineering Research, Vol. 9, No. 11 (2014), pp 1691~1700.
3. Xu Heli, "bration Characteristics of a ship flowline system", 2008 - Huazhong University of Science and Technology: Power Machinery and Engineering, pp 19~21