

# Trichel Pulse in Negative DC Corona discharge and Its Electromagnetic Radiations

Yu Zhang\*, Li-Juan Liu\*, Jin-Song Miao\*, Zu-Lin Peng\* and Ji-Ting Ouyang<sup>†</sup>

**Abstract** – We investigate in this paper the radiated electromagnetic waves together with the discharge characteristics of Trichel pulse of negative DC corona discharge in air in pin-to-plate and wire-to-plate configurations. The feature of the current pulse and the frequency spectrum of the electromagnetic radiations were measured under various pressures and gas gaps. The results show that the repetition frequency and the amplitude of Trichel pulse current depend on the discharge conditions, but the rising time of the pulse relates only to the radius of needle or wire and keeps constant even if the other conditions (including the discharge current, the gas gap and the gas pressure) change. There exists the characterized spectrum of electromagnetic waves from negative corona discharge in Trichel pulse regime. These characterized radiations do not change their frequency at a given cathode geometry even if the averaged current, the gas gap or the air pressure changes, but the amplitude of radiations changes accordingly. The characterized electromagnetic radiations from Trichel pulse corona relate to the formation or the rising edge of current pulse. It confirms that the characterized radiations from Trichel pulse supply information of discharge system and provide a potential method for detecting charged targets.

**Keywords:** Negative corona discharge, Trichel pulse, Electromagnetic radiation, Rising time

## 1. Introduction

The Corona discharge has been known for a long time as a self-sustained discharge which occurs if the electric field is sharply non-uniform [1, 2]. Typical corona discharges include the discharge in needle-to-plate or wire-to-plate configurations used in electrostatic precipitator or in a dielectric body with a high electrostatic voltage. Generally, the corona discharge in air is not stable. Instead, there exists an unstable regime (random or regular pulses) of the corona discharge, resulting in the electromagnetic (EM) radiation emitted from the pulses. This makes the corona discharge being one of the important sources of electromagnetic interference (EMI) in electric power and electronic systems. It is therefore interesting and important to investigate the EM radiations from the corona discharges [3-5]. From the aspect of insulation condition monitoring, Chen et al. studied the electromagnetic wave from corona discharge in needle-to-plate configuration [6]. Although a physical model was used in discussions, the effects of discharge parameters on the radiation were not discussed. The frequency spectrum of radiation from discharges was analyzed by Park et al. but their works mainly focused on the best frequency width for measurement [7]. On one hand, knowing the radiation characteristics is essential for both evaluation and measurement of EM environment, as

well as protection against EMI. On the other hand, the EM radiation from the corona discharge might also supply some information of the charged body or discharge system, which indicates a potential method to detect the charged targets. Actually, there were few investigations on the correlations between EM radiations and the corona discharge configurations.

In this paper, we investigate the characteristics of Trichel pulse and the EM radiation of negative corona discharge in air. The effect of discharge parameters on the Trichel current pulse and the characterized EM radiations has been discussed. The correlations between radiation and discharge system are discussed in detail, which may provide promising method for evaluation of insulation condition of electric apparatus as well as detection of the charged body.

## 2. Experimental setup

The experimental set-up is schematically shown in Fig. 1. We employed needle-to-plate or wire-to-plate configuration. The discharge system is placed inside a chamber so that it can be operated under various pressures. A high dc negative voltage is applied on the needle (or wire) and the plate anode is grounded through a non-inductive resistor  $R$ . The radius of needle tip or wire and the gas gap between the electrodes are changeable and their effects on the discharge are examined in experiments. The applied voltage is measured by a digital Oscilloscope (Tektronix TDS-3054B, 500 MHz-bandwidth and 5 G/s sampling rate) through a

<sup>†</sup> Corresponding Author: School of Physics, Beijing Institute of Technology, Beijing, China. (jtouyang@bit.edu.cn)

\* School of Physics, Beijing Institute of Technology, Beijing, China. (zhangyustudy, @126.com)

Received: March 25, 2014; Accepted: December 29, 2014

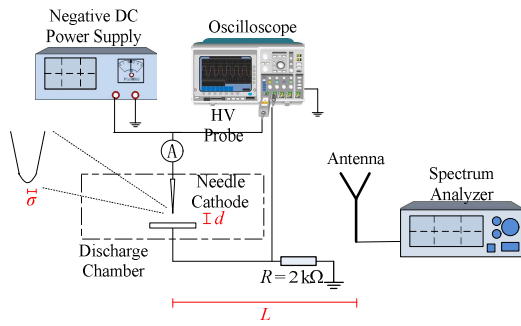

Fig. 1. Schematic of the experimental set-up

HV probe (Tektronix P6015A), and the waveform of discharge current through the electric circuit is sampled by the resistor  $R = 2 \text{ k}\Omega$ , given by  $I = V_R/R$ . An Ampere-meter is used to measure the averaged current of the corona discharge. A Spectrum Analyzer (RIGOL DSA815, with frequency range 9kHz ~1.5GHz) together with a broadband antenna (Discone Antenna OX-08-02, from 10 MHz ~ 1 GHz) is used to measure the EM radiations from the corona discharge. The antenna is placed several meters away from the discharge chamber.

### 3. Results

#### 3.1 Voltage-current characteristic of negative corona

We first measure the voltage-current ( $V$ - $I$ ) characteristics of negative corona in air at various pressures. The air temperature is  $T = 25^\circ\text{C}$  and the relative humidity  $RH$  is about 50%. Fig. 2 shows the  $V$ - $I$  characteristics of needle-to-plate negative corona in air at different pressures for gas gap of  $d = 3.5 \text{ mm}$ . Physically, the  $V$ - $I$  characteristic of the negative corona discharge can be separated into several stages: the corona discharge occurs above a critical voltage and then the current increases with the applied voltage until spark bridges the gap.

The  $V$ - $I$  characteristic of negative corona discharge follows the classical Townsend's relation [1], or  $I = kU(U-U_C)$  (where  $k$  is a constant decided by discharge

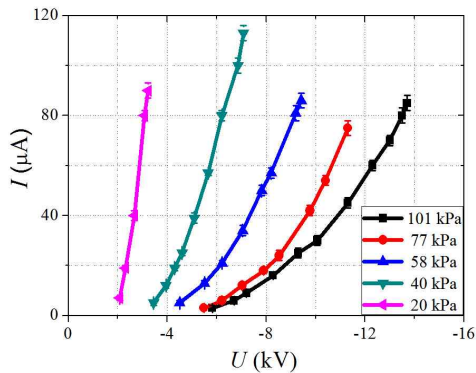

Fig. 2.  $V$ - $I$  curve of negative corona in air at different pressures.

configuration and mobility of participant particles and  $U_C$  is the corona inception voltage). In the present conditions the inception voltage is  $U_C = -5.8, -5.5, -4.5, -3.5$  and  $-2.0 \text{ kV}$  at air pressure of  $p = 101, 77, 58, 40$  and  $20 \text{ kPa}$ , respectively. Decreasing pressure leads to a drop of both corona inception voltage and breakdown voltage for spark.

The negative corona discharge at low or medium current may show very regular pulses. This pulse regime carries the name of Trichel pulse [8]. As the applied voltage or the averaged current increases, the pulsing frequency increases until there appears a stable glow discharge. The transition to the pulseless discharge occurs at a critical voltage and limited frequency. This steady-state glow will sustain until the spark bridges electrode gap. In some cases, the transition from pulsed corona to spark is sudden and there is no steady glow stage.

#### 3.2 Trichel pulse

When the negative corona enters the stage of Trichel pulse, the current shows a regular pulse and highly repeatable. The typical current waveform is shown in Fig. 3 for gas gap of  $3.5 \text{ mm}$  at applied voltage of  $\sim 11 \text{ kV}$  and averaged current of  $\sim 42 \mu\text{A}$ . From Fig. 3, the time interval between the pulses is  $t_w = 1.14 \mu\text{s}$  (corresponding to repetition frequency of  $877 \text{ kHz}$ ) and the rising time of the pulse is  $t_r \sim 20 \text{ ns}$ .

The repetition frequency  $f$  of the Trichel pulse always performs as a function of the averaged current  $I$ . The relation is shown in Fig. 4 for example of  $d = 3.5 \text{ mm}$  at different pressures. The radius of the cathode needle is  $70 \mu\text{m}$ . It is seen that the frequency increases linearly with the average current and ranges from  $1 \text{ kHz}$  to about  $1 \text{ MHz}$ . This is similar to the previous results [8-13]. The air pressure also has significant effect on the repetition frequency when the averaged current is the same. As seen in Fig. 4 that the Trichel pulse appears more frequently under higher pressures.

The amplitude  $I_p$  of the current pulse changes with the discharge parameters, as shown in Fig. 5 (a) for different pressures and (b) for different gas gaps. Decreasing the air pressure  $p$  or the gap distance  $d$  (i.e. a smaller  $pd$  value)

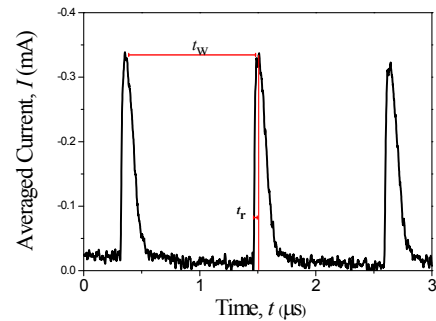

Fig. 3. Typical waveform of Trichel pulse of needle-to-plate corona in air at atmospheric pressure for averaged current of  $42 \mu\text{A}$ .

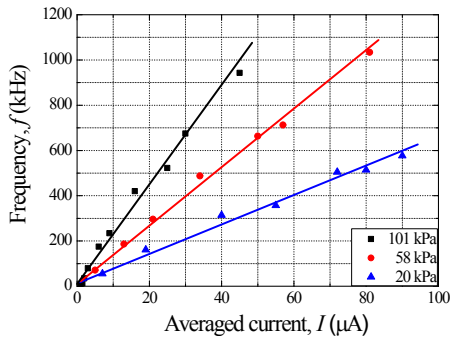

Fig. 4. The repetition frequency of Trichel pulse at different pressures.

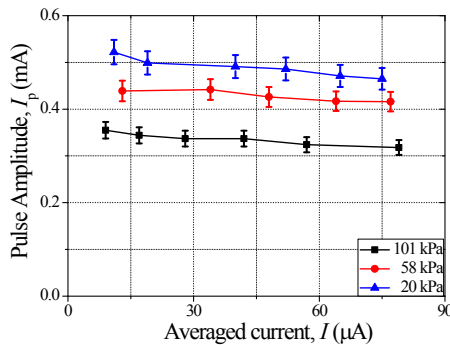

Fig. 5 (a) The amplitude of Trichel current pulse changes with the averaged current at different pressures  $p = 101, 58$  and  $20$  kPa.

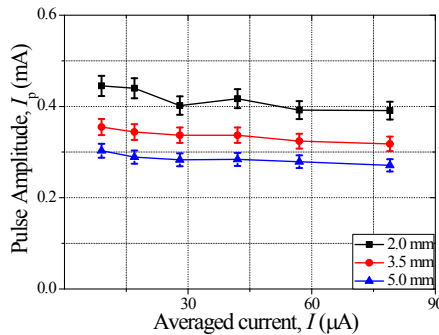

Fig. 5. (b) The amplitude of Trichel current pulse changes with the averaged current at different gaps  $d = 2.0, 3.5$  and  $5.0$  mm.

leads to an increase of the current amplitude  $I_p$ . But the averaged current only causes a very slight decrease of the pulse amplitude.

Different from the repetition frequency and the current amplitude, the rising time  $t_r$  of the Trichel pulse is almost constant for different discharge current, pressure or gas gap, as shown in Fig. 6. The rising time is  $t_r = 20 (\pm 2)$  ns (marked as the shadow part in Fig. 6). Namely, the averaged current, the air pressure or the gas gap has no obvious influence on the rising time of Trichel pulse. This indicates that the rising time is a characterized property of Trichel pulse corona in air. It is determined by the formation process of pulsed current [1, 14]. Similar results

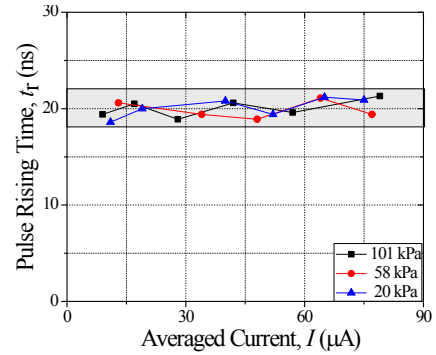

Fig. 6. (a) The rising time of Trichel pulse changes with the averaged current at different pressures  $p = 101, 58$  and  $20$  kPa.

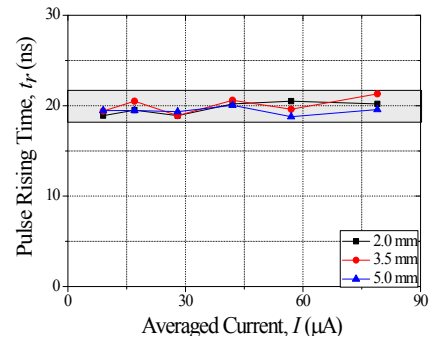

Fig. 6. (b) The rising time of Trichel pulse changes with the averaged current at different gaps  $d = 2.0, 3.5$  and  $5.0$  mm.

were obtained in wire-to-plate configuration in the present experiments.

However, the radius of needle cathode may affect the rising time of Trichel pulse. Generally, increase of the tip radius results in an increase of the rising time. For needle-to-plate configuration,  $t_r = 17, 20$  and  $36$  ns for needle radius of  $\sigma = 50, 70$  and  $200 \mu\text{m}$ , respectively. For wire-to-plate configuration,  $t_r = 22, 29$  and  $32$  ns for wire radius of  $50, 100$  and  $150 \mu\text{m}$ , respectively. The results are listed in Table 1.

### 3.3 EM radiation

When the negative corona operates in Trichel pulse regime, some specialized EM radiations are emitted from the discharge. The EM radiations are stable and repeatable. Typical EM signals are shown in Fig. 7 for needle-to-plate corona with needle radius of  $\sigma = 70 \mu\text{m}$  and wire-to-plate corona with wire radius of  $\sigma = 100 \mu\text{m}$ . The antenna was  $3$  m away from discharge cell. It is seen that there is a series of radiation signal bands. For needle-to-plate corona, the central frequency  $f_c$  of the spectra appears at  $55$  and  $110$  MHz, and for wire-to-plate appears around  $43, 85$  and  $124$  MHz, respectively. The spectra shows a base frequency together with some multiples (twice of and triple of the base). These radiation spectra are very stable and do not

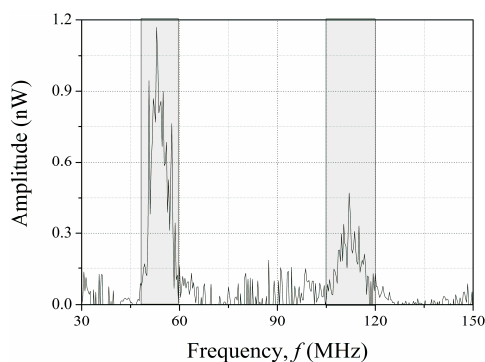

Fig. 7. (a) The EM radiations of the Trichel pulse for needle-to-plate corona (tip radius,  $\sigma = 70 \mu\text{m}$ )

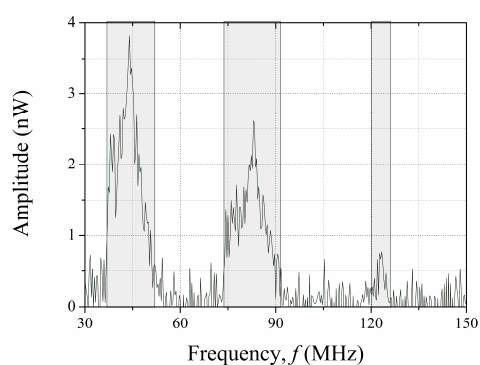

Fig. 7. (b) The EM radiations of the Trichel pulse for wire-to-plate corona (radius,  $\sigma = 70 \mu\text{m}$ )

change their position on Spectrum Analyzer when the averaged current (or the applied voltage) changes.

We found in experiment that the characterized EM spectra also do not change with the gas pressure or the gas gap. The only change on the radiation signals is the amplitude which relates to the averaged current, the pressure or the gas gap.

However, the frequency of the EM radiations depends on the cathode geometry, as shown in Table 1. Generally, a sharper needle or wire cathode results in a shorter rising time of Trichel pulse and higher radiation frequency. For instance, the base frequency of the measured EM radiation in needle-to-plate corona decreases from 75 MHz at  $\sigma = 50 \mu\text{m}$  to 38 MHz at  $\sigma = 200 \mu\text{m}$ , while the rising time of the Trichel pulse increases from 17 ns to 36 ns.

In any case, once the cathode geometry is given, the positions of the EM radiation signals on the Spectrum Analyzer will be determined. The change of the averaged current, the air pressure, or the gap distance only influence the amplitude of the EM signals, but not the radiation frequency.

When the negative corona discharge transit into a steady-state glow at a critical voltage, the characterized EM radiations disappear immediately. Or, when the spark bridges the needle-to-plate gap at very high voltage, the EM radiations become random on the Spectrum Analyzer and no longer characterized [14].

Table 1. Pulse rising time under different cathode configurations

Tip radius $\sigma$ ( $\mu\text{m}$ )	Pulse rising time $t_r$ (ns)	Central frequency $f_c$ (MHz)
Needle-to-plate		
50	17	75 and 133
70	20	55 and 110
200	36	38 and 72
Wire-to-plate		
50	22	58 and 121
100	29	43, 85 and 124
150	32	39, 77 and 111

#### 4. Discussions

We have shown that there exist characterized EM radiations from Trichel pulse corona in air. Since the frequency of these EM radiations (ranging from tens to hundreds of MHz in experiments) is much higher than the repetition frequency of the pulse (from 1 kHz to around 1 MHz) that also changes with the discharge current as well as the gas gap and gas pressure, the EM radiation should not be due to the repetition frequency but the formation of Trichel pulse, or the rising of the current pulse.

The Trichel pulse is suggested to be a self-pulsing discharge in electronegative gases (e.g. air). The negative ions play an important role in the formation of Trichel pulse and no Trichel pulse was observed in electropositive gases [1, 2, 8-13]. The most important characteristics of Trichel pulse are the repetition frequency and the rising time of the current pulse. The former one is mainly controlled by the removal process of negative ions that determines the repetition frequency. The latter is determined by the electron motion in electric field near breakdown [1, 14]. The avalanche develops according to the Townsend mechanism and this process determines the rising edge of the pulse current. The rising time of Trichel pulse is decided as  $t_r \sim d_c / (\mu_e E)$  [1, 8, 14], where  $d_c$  is the distance threshold of electron avalanche,  $\mu_e$  is the mobility of electron and  $E$  is the electric field. Under the same voltage, stronger electric field is produced around the tips with smaller radius. Thus, the Trichel pulse by sharper cathode has a shorter rising time.

The current of Trichel pulse can be featured as double-exponential function [15] written as:

$$I(t) = I_0 (e^{-t/\alpha} - e^{-t/\beta}) \quad (1)$$

where  $I_0$  is the maximum of the current,  $\alpha$  and  $\beta$  are time constant for the rising and decay. Fig. 8 shows the measured and simulated current pulse (which have been normalized) for needle-to-plate corona with  $\sigma = 70 \mu\text{m}$  at averaged current of 42  $\mu\text{A}$ . The time for rising is 20 ns and for decay is 185 ns, respectively. The repetition frequency is 877 kHz.

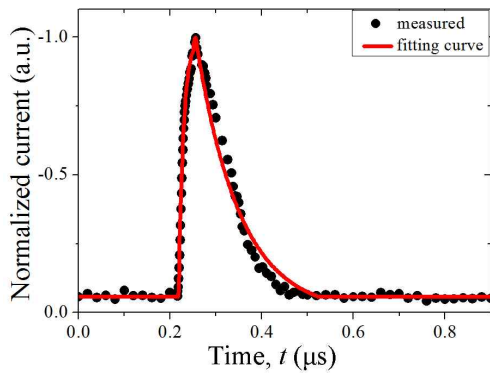

Fig. 8. Measured current and fitting curve by double-exponential function.

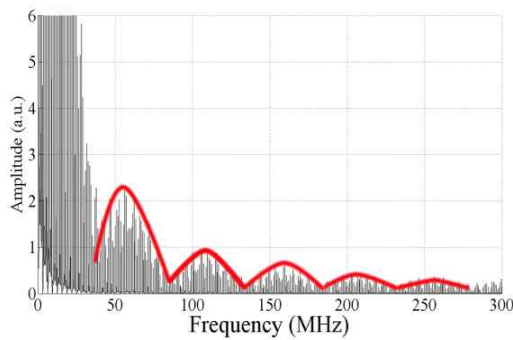

Fig. 9. FFT spectra of current pulse in Fig. 8.

Then we can employ the Fast Fourier Transform (FFT) method to analyze the radiation from the current pulse. The method is adopted and the FFT result of the current (shown in Fig. 8) is given in Fig. 9.

It is seen that the FFT spectra consist of a series of enlarged envelopes, including a base frequency band (centered at 55 MHz), the double-frequency band (centered at 110 MHz), the triple-frequency band (centered at 160 MHz), and so on. The base band is the strongest in amplitude. The amplitude of the other radiation of multiple-frequencies decreases with the frequency. Actually, the frequency bands above 150 MHz are too weak to be observed in experiments. The spectrum below 30 MHz is scarcely measurable.

By this method, radiation spectra of Trichel pulse under different conditions can be got. The results show that the frequency of the radiation spectra depends strongly on the rising time of current from FFT, as shown in Fig. 10. The square or circle symbols in Fig. 10 represent the experimental results of needle-to-plate or wire-to-plate corona and lines represent the results from FFT method. The calculated FFT frequency at increasing rising time is in well agreement with the experimental results, showing that the increase of the rising time results in a decrease of the radiation frequencies.

The FFT also shows that the decay time of the pulse and the repetition frequency will not affect the radiation

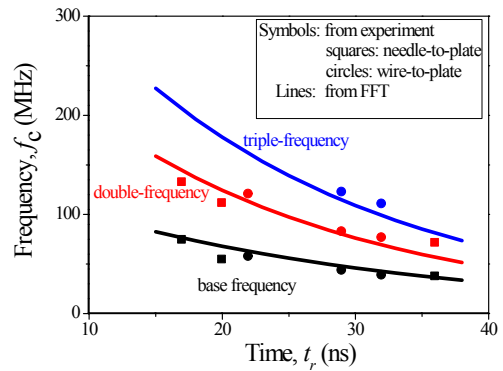

Fig. 10. Frequency of EM radiations from Trichel pulse corona as a function of rising time.

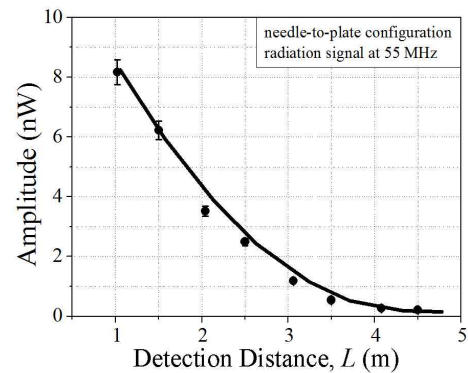

Fig. 11. The EM radiations signal changes with antenna distance.

frequency, but causes a change in the radiation strength. This indicates that once the rising time of the current pulse is given, the radiation frequencies are determined accordingly. The decay time or the pulse repetition frequency has almost no influence on the radiation frequency which is also observed in our experiments.

Actually, the EM radiation reduces its amplitude as the antenna moves away from the discharge cell. The relation between the signal amplitude and the distance follows the EM radiation of the current element model in far-field approximation [16] that has the energy flux density of

$$\bar{S} = \frac{I^2 s^2}{8 f^2 c^2 R^2} \sqrt{\frac{\mu}{\epsilon}} \sin 2\theta \bar{e}_R \quad (2)$$

where  $R$ ,  $\theta$  are spherical coordinates,  $I$  is the current of element and  $s$  is the length,  $\epsilon$  is the permittivity and  $\mu$  is the magnetic permeability,  $f$  is the radiation frequency and  $c$  is the speed of light in vacuum. This has been confirmed in experiment as shown in Fig. 11 for example of radiation frequency at 55 MHz of needle-to-plate corona with  $\sigma = 70 \mu\text{m}$ . The radiation amplitude is inversely proportional to square of detection distance and becomes too weak to detect beyond 5 m.

## 5. Conclusion

In summary, we have investigated the discharge characteristics and the EM radiations of the negative corona discharge in air. The correlations between EM radiation and discharge part are discussed. Through the achievements, a promising method for evaluation of insulation condition as well as charged-body detection by measuring radiation from corona discharge is provided. The results are noted as follows:

In the present experiment, Trichel pulse is generated in negative corona using needle/wire cathode with various tip radius (i.e. needle with tip radius  $\sigma = 50, 70, 100 \mu\text{m}$  and wire with radius  $\sigma = 50, 100 \mu\text{m}$ ). There exist the characterized EM radiations under 150 MHz from Trichel pulse corona. The frequency spectrum includes a base frequency and multiple frequencies. They are absent in the steady-state glow or spark mode.

The frequency spectrum of the characterized EM radiations only depends on the cathode geometry (i.e. the radius of needle or wire), but does not change with the averaged current, the electrode gap or the air pressure. Correspondingly, the waveform and the rising time of Trichel pulse also only relates to cathode geometry rather than the current, the pressure or the gap.

The amplitude of the EM radiations changes with the averaged current, the pressure and the gas gap. At given discharge conditions, the amplitude decreases with the detection distance according to inverse square function.

The characterized EM radiations relate to the rising of the Trichel current pulse. A sharper needle or wire results in a shorter rising time of the pulsing current and higher-frequency EM radiations.

## Acknowledgements

This work was supported partly by the National Key Laboratory of Science and Technology on Electro-mechanical Dynamic Control of China (2011C3606).

## References

- [1] Raizer. Yu. P, Gas Discharge Physics. Berlin: Springer, 1991.
- [2] M. Golden, and A. Golden, Corona Discharge. In: M. Hirsh, and H. J. Oskam, Gaseous Electronics. New York: Academic, 1978.
- [3] Y. Akishev, M. Grushin, I. Kochetov, V. Karal'nik, A. Napartovich, and N. Trushkin, "Negative corona, glow and spark discharges in ambient air and transitions between them," Plasma Sources Science and Technology, Vol. 14, No. 2, pp. S18-S25. May, 2005.
- [4] J. Zhang, and K. Adamiak, "A single-species pulsed model of negative corona discharge in air," IEEE Transaction on Industry Applications, Vol. 44, No. 2, pp. 494-500. March, 2008.
- [5] W. D. Liu, S. H. Liu, X. F. Hu, and Q. Y. Yuan, "Experimental analysis on radiation characteristics of point corona discharge," High Voltage Apparatus, Vol. 44, No.1, pp. 20-22. January, 2008.
- [6] S. X. Chen, Y. L. Sun, and H. K. Xie, "Characteristics of electromagnetic wave radiated from corona discharge," Proceeding of IEEE International Symposium on Electromagnetic Compatibility, Vol. 2, pp. 1279-1282. August, 2001.
- [7] D. W. Park, G. S. Kil, S. G. Cheon, S. J. Kim, and H. K. Cha, "Frequency spectrum analysis of electromagnetic waves radiated by electric discharges," Journal of Electrical Engineering & Technology, Vol. 7, No. 3, pp. 389-395. May, 2012.
- [8] G. W. Trichel. "The mechanism of negative point to plane corona near onset," Physical Review, Vol. 54, No. 12, pp. 1078-1084. December, 1938.
- [9] W. L. Lama, and C. F. Gallo, "Systematic study of the electrical characteristics of the 'Trichel' current pulses from negative needle-to-plane coronas," Journal of Applied Physics, Vol. 45, No. 1, pp. 103-113, 1974.
- [10] P. Sattari, C.F. Gallo, G.S.P. Castle, and K. Adamiak, "Trichel pulse characteristics - negative corona discharge in air," Journal of Physics D: Applied Physics, Vol. 44, No. 15, 155502. March, 2011.
- [11] D. A. Scott, and G. N. Haddad, "Negative corona in nitrogen-oxygen mixtures," Journal of Physics D: Applied Physics, Vol. 20, No. 8, pp. 1039-1044. August, 1987.
- [12] R. Morrow, "Theory of stepped pulses in negative corona discharges," Physical Review A, Vol.32, No.6, pp. 3821-3824. December, 1985.
- [13] P. Sattari, G. Castle, and K. Adamiak, "Numerical simulation of Trichel pulses in a negative corona discharge in air," IEEE Transactions on Industry Application, Vol. 47, No. 4, pp. 1935-1943, May, 2011.
- [14] J. T. Ouyang, Z. L. Zhang, Y. Zhang and Z. L. Peng," Experimental study on the characteristics of negative-corona Trichel pulses in air," In Chinese, High Voltage Engineering, Vol. 40, No. 4, pp. 1994-2000, April, 2014.
- [15] S. K. Nayak, and M. J. Thomas, "A novel technique for the computation of radiated EMI due to corona on HV transmission lines", IEEE International Symposium on Electromagnetic Compatibility, Vol. 2, pp. 738-742, August, 2003.
- [16] D. K. Cheng, Field and Wave Electromagnetics. Addison-Wesley, 1989.



**Yu Zhang** He received B.Sc. degree from the Department of Physics, Beijing Institute of Technology, China in 2011. He is currently working toward the Ph.D. degree in the Research Center for Electrostatics and Applications, BIT. His research interests include corona discharges, electrostatic discharges and their applications. E-mail: zhangyustudy@126.com



**Li-Juan Liu** She received the M.Sc. degree from the Beijing Institute of Technology, China in 2010. She is currently working toward the Ph.D degree in the Research Center for Electrostatics and Applications, BIT. Her research interest includes the mechanism and application of the atmospheric pressure plasma jet. E-mail: liulj3000@126.com



**Jin-Song Miao** He received the B.Sc. degree in Physics from Shanghai Jiao-tong University, Shanghai, the M.Sc. degree in Physics from Sichuan University, Chengdu, China, and the Ph.D degree in Mechanical Manufacture from Essen University, Essen, Germany in 1988, 1991 and 2003, respectively. He is currently an associate professor with the School of Physics, and the director of the Research Center for Electrostatics and Applications, BIT. His research interests include physics, applications of electrostatics and discharge plasma. E-mail: jinsong.miao@bit.edu.cn



**Zu-Lin Peng** He received the B.Sc. degree in Physics from Beijing Institute of Technology, in 1991, and the M.Sc. degree in Beijing Institute of Technology in 2007. He is currently an associate professor with the School of Physics, BIT. His research interests include applications of electrostatics and discharge plasma. E-mail: pclin@bit.edu.cn

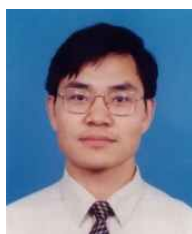

**Ji-Ting Ouyang** He received the B.Sc. degree in Physics from Zhejiang University, Hongzhou, the M.Sc. degree in Physics from the Institute of Physics, Chinese Academy of Sciences, Beijing, and the Ph.D degree in Mechanism and Electronic Engineering from Beijing Institute of Technology (BIT), Beijing, China in 1988, 1991 and 1999, respectively. He is currently a professor with the School of Physics, and the director of the Research Center for Electrostatics and Applications, BIT. His research interests include physics, generation and applications of discharge plasma at various pressures. E-mail: jtouyang@bit.edu.cn