

Common Mode Noise Reduction for an LLC Resonant Converter by Using Passive Noise Cancellation

Younggon Ryu¹ · Sunnam Kim² · Geunseok Jeong² · Jaesu Park² · Duil Kim² ·
Jongwook Park² · Jinguok Kim¹ · Ki Jin Han^{1,*}

Abstract

This paper describes the application of a passive noise cancellation method to a prototype inductor-inductor-capacitor (LLC) resonant converter by placing a compensation winding in a transformer to reduce common mode noise. The connection method for the compensation winding is investigated. A circuit analysis is implemented for the displacement currents between the primary and secondary windings in the transformer. The analyzed displacement currents are verified by performing a circuit simulation and a proper compensation winding connection that reduces common mode noise is found. The measurement results show that common mode noise is reduced effectively up to 20 dB in the 1 to 7 MHz frequency region for the prototype LLC resonant converter by using the proposed passive noise cancellation method.

Key Words: Common Mode Noise, Electromagnetic Compatibility, LLC Resonant Converter, Passive Noise Cancellation.

I. INTRODUCTION

Switch mode power supplies (SMPS) that use converters are commonly used in today's electronic products and industrial appliances. However, these converters are controlled by pulse width modulation (PWM), which means that electrical noise is generated due to rising and falling transients, and a common mode (CM) noise path is formed by the parasitic couplings in the circuit board. CM noise degrades system performance and may violate the regulations for conducted emissions.

A passive noise cancellation method has been proposed to reduce CM noise [1–3]. This method places a compensation winding in the transformer, thereby effectively reducing CM

noise for buck, boost, buck-boost, and flyback converters.

The passive cancellation method can be applied to an inductor-inductor-capacitor (LLC) resonant converter as well. However, a direct application of the compensation winding used in other converters is not available, since the winding method in the LLC resonant converter is designed to obtain a large leakage inductance [4]. Therefore, a better approach needs to be considered when applying the passive noise cancellation method to an LLC resonant converter.

In this paper, we analyze the passive noise cancellation method for application to the LLC resonant converter. For the design of the compensation winding, we investigate the displacement currents flowing through the winding-to-winding capacitances in the transformer. By using circuit analysis

Manuscript received December 8, 2014 ; Revised February 28, 2015 ; Accepted April 6, 2015. (ID No. 20141208-064J)

¹School of Electrical and Computer Engineering, Ulsan National Institute of Science and Technology, Ulsan, Korea.

²LG Electronics, Pyeongtaek, Korea.

*Corresponding Author: Ki Jin Han (e-mail: kjhan@unist.ac.kr)

This is an Open-Access article distributed under the terms of the Creative Commons Attribution Non-Commercial License (<http://creativecommons.org/licenses/by-nc/3.0>) which permits unrestricted non-commercial use, distribution, and reproduction in any medium, provided the original work is properly cited.

© Copyright The Korean Institute of Electromagnetic Engineering and Science. All Rights Reserved.

and simulating the displacement currents, we propose a feasible connection method that can reduce CM noise. A prototype half-bridge LLC resonant converter is designed by applying the proposed connection method. The observed measurement results confirm that the passive cancellation method can effectively reduce CM noise for the LLC resonant converter.

II. METHODOLOGY

The circuit diagram that includes a compensation winding to reduce CM noise for a single-output half-bridge LLC resonant converter is shown in Fig. 1. The most dominant CM noise path is through the primary-to-secondary winding capacitance (C_{ps}) in the transformer because the system uses separate grounds. The addition of a compensation winding that has the same amount of parasitic capacitance C_{cs} as C_{ps} can cancel the CM noise because the compensation winding generates the same magnitude and anti-polarity parasitic current against the CM noise current.

In this paper, we apply the compensation winding to the transformer shown in Fig. 2, which can be used for the dual-output half-bridge LLC resonant converter. The transformer

is for dual-output, so windings A and B constitute one of the outputs, and the other windings C and D are for the other output. Normally, the primary and the secondary windings overlap in the transformer to minimize leakage inductance. However, in the transformer shown in the figure, the primary and secondary windings are separated to obtain a large and controllable value of leakage inductance, because leakage inductance is used as the resonant-tank series inductance [4]. By overlapping with the primary winding through other pins, the compensation winding can be connected to the transformer. Therefore, the method to match the parasitic capacitances (C_{cs} and C_{ps}) should differ from the method used in conventional transformers because of the different winding structure.

Cross sections of the upper sides of the transformers with compensation windings are described in Fig. 3. The traditional overlapped winding transformer shown in Fig. 3(a) requires the connection of an additional capacitor to the compensation winding [1, 2], or adjustment of the compensation winding turn number [3], because C_{cs} has a different value from C_{ps} due to their different distances from the secondary winding. However, in the transformer for the LLC resonant converter, C_{cs} can be set at almost the same value as C_{ps} as long as the compensation winding has the same number of turns and the layer arrangement with the primary winding is as shown in Fig. 3(b). As C_{cs} can be

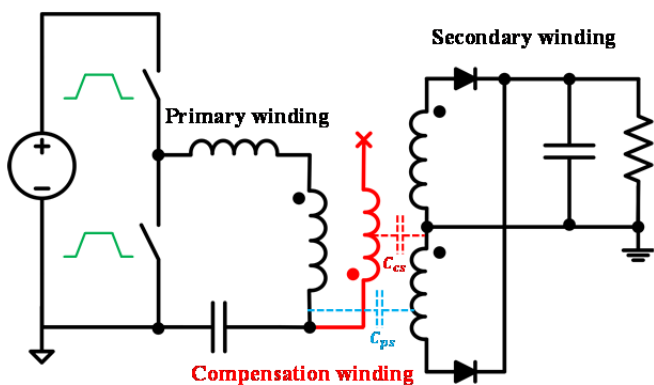
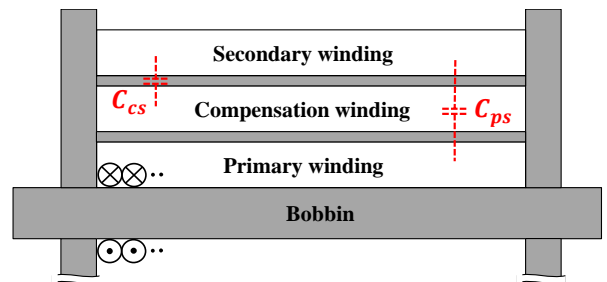
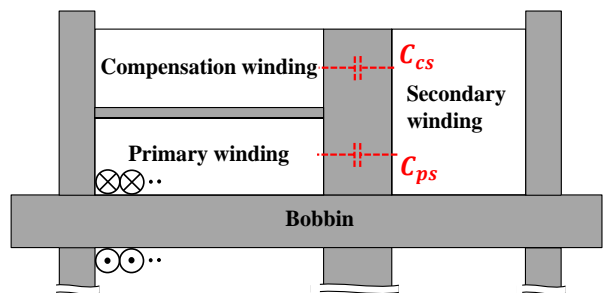

Fig. 1. A half-bridge inductor-inductor-capacitor (LLC) resonant converter with a compensation winding.



(a)



(b)

Fig. 3. (a) Parasitic capacitances of overlapped windings in a conventional transformer. (b) Parasitic capacitances of an inductor-inductor-capacitor (LLC) resonant converter transformer.

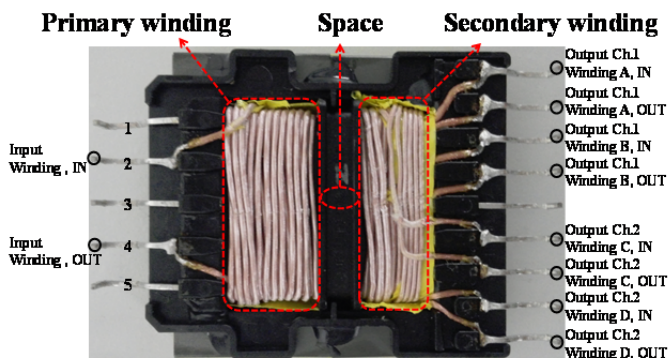

Fig. 2. A transformer for a dual-output half-bridge inductor-inductor-capacitor (LLC) resonant converter.

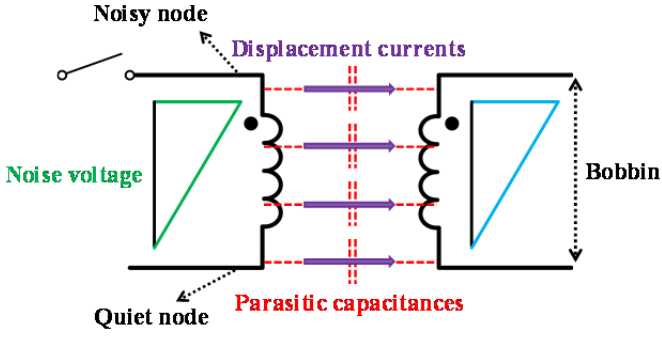

Fig. 4. Displacement currents between the primary and secondary windings, and noise voltages along the windings.

adjusted by the winding method only, it does not need any additional capacitor. That is, the end of the compensation winding remains open.

The compensation winding is added as an open circuit;

therefore, it does not affect normal converter operation. This winding only produces a path for high frequency harmonics, which are generated by the rising and falling transients in the switches through the parasitic capacitance between the compensation winding and the secondary winding.

III. DISPLACEMENT OF CURRENT AND NOISE VOLTAGE

A description of the displacement currents in the transformer is shown in Fig. 4, where the node connected directly to the switches is named ‘noisy node’ and the other side is named ‘quiet node.’ The induced noise voltages along the primary and the secondary windings are indicated in the figure. We can see that the highest noise voltage is induced on the noisy node, and the noise voltage has the lowest value on the quiet node.

The compensation winding can be connected to the pri-

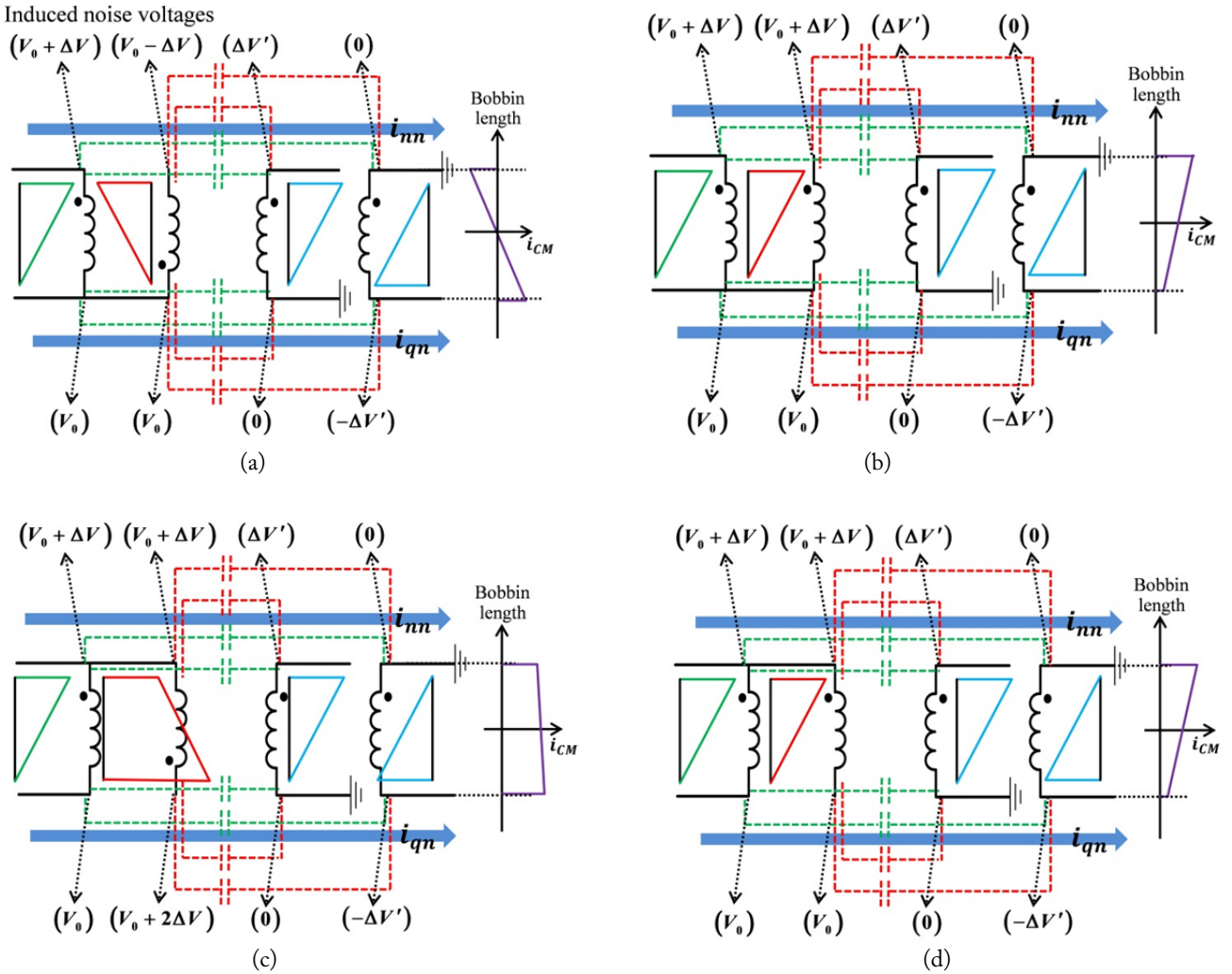

Fig. 5. Analysis of the displacement currents and the induced noise voltages along the bobbin length of transformers with different connection types of compensation winding. (a) Quiet node and anti-polarity connection. (b) Quiet node and same-polarity connection. (c) Noisy node and anti-polarity connection. (d) Noisy node and same-polarity connection.

mary winding in four ways, as shown in Fig. 5. The windings are constituted for a half-bridge and single output type. The single-output analysis can be applied to the dual-output case by a simple extension that includes additional windings in parallel. The connection methods are classified according to the connected node and the polarity of the compensation winding. With the induced noise voltage on all nodes, including the secondary winding, the displacement currents flow from the noisy and the quiet nodes to the earth ground. For the quiet node and the anti-polarity connection type, which are shown in Fig. 5(a), the displacement currents can be calculated as follows:

$$i_{nn} = C_{ps} \left(\frac{\Delta V}{dt} - \frac{\Delta V'}{dt} + \frac{\Delta V}{dt} - \frac{\Delta V}{dt} - \frac{\Delta V'}{dt} - \frac{\Delta V}{dt} \right) = C_{ps} \left(-\frac{2\Delta V'}{dt} \right) \quad (1)$$

$$i_{qn} = C_{ps} \left(\frac{\Delta V'}{dt} + \frac{\Delta V'}{dt} \right) = C_{ps} \left(\frac{2\Delta V'}{dt} \right) \quad (2)$$

This analysis includes two assumptions. First, the parasitic capacitances have almost the same value ($C_{ps} \approx C_{cs}$). Second, all of the CM noise passes through the transformer because the most dominant CM noise path in the circuit is through the winding-to-winding capacitances of the transformer. Therefore, we can assume that the noise voltage V_0 is zero.

Similarly, the displacement currents for the other connection types can be calculated. The displacement currents for the quiet node and same-polarity connection shown in Fig. 5(b) are:

$$i_{nn} = C_{ps} \left(\frac{\Delta V}{dt} - \frac{\Delta V'}{dt} + \frac{\Delta V}{dt} + \frac{\Delta V}{dt} - \frac{\Delta V'}{dt} + \frac{\Delta V}{dt} \right) = C_{ps} \left(\frac{4\Delta V}{dt} - \frac{2\Delta V'}{dt} \right) \quad (3)$$

$$i_{qn} = C_{ps} \left(\frac{\Delta V'}{dt} + \frac{\Delta V'}{dt} \right) = C_{ps} \left(\frac{2\Delta V'}{dt} \right) \quad (4)$$

The displacement currents for the noisy node and anti-polarity connection shown in Fig. 5(c) are:

$$i_{nn} = C_{ps} \left(\frac{\Delta V}{dt} - \frac{\Delta V'}{dt} + \frac{\Delta V}{dt} + \frac{\Delta V}{dt} - \frac{\Delta V'}{dt} + \frac{\Delta V}{dt} \right) = C_{ps} \left(\frac{4\Delta V}{dt} - \frac{2\Delta V'}{dt} \right) \quad (5)$$

$$i_{qn} = C_{ps} \left(\frac{\Delta V'}{dt} + \frac{2\Delta V}{dt} + \frac{2\Delta V}{dt} + \frac{\Delta V'}{dt} \right) = C_{ps} \left(\frac{4\Delta V}{dt} + \frac{2\Delta V'}{dt} \right) \quad (6)$$

The displacement currents for the noisy node and same-polarity connection shown in Fig. 5(d) are:

$$i_{nn} = C_{ps} \left(\frac{\Delta V}{dt} - \frac{\Delta V'}{dt} + \frac{\Delta V}{dt} + \frac{\Delta V}{dt} - \frac{\Delta V'}{dt} + \frac{\Delta V}{dt} \right) = C_{ps} \left(\frac{4\Delta V}{dt} - \frac{2\Delta V'}{dt} \right) \quad (7)$$

$$i_{qn} = C_{ps} \left(\frac{\Delta V'}{dt} + \frac{\Delta V'}{dt} \right) = C_{ps} \left(\frac{2\Delta V'}{dt} \right) \quad (8)$$

The displacement currents along the bobbin length for each connection type are described in Fig. 5. The total CM noise current should be equal to the integration of the displacement currents along the bobbin length. In the case of the quiet node and anti-polarity connection, which are shown in Fig. 5(a), the distribution of the displacement currents between the quiet node and the noisy node is symmetrical along the i_{CM} -axis. Therefore, we can expect that only the quiet node and anti-polarity connection method will cancel the total CM noise current because the displacement currents produced by the compensation winding have the same magnitude and different polarity values against the displacement currents of the primary winding on the end nodes.

IV. SIMULATION RESULTS

The simulation results of the displacement currents on the quiet and noisy nodes for each connection type are shown in Fig. 6. When we observe the magnitude and polarity of the simulated displacement currents, we find that the analyzed displacement currents in the previous section are in good agreement with the results of the circuit simulation.

The total CM noise current for the LLC resonant converter can be calculated by adding all the displacement currents shown in Fig. 6; the results are shown in Fig. 7. In addition, the total CM noise currents for the converter with the compensation winding are compared to those of the original converters, which do not have the compensation winding. As shown in Fig. 7(a), the total CM noise can be reduced effectively only by the method of the quiet node and anti-polarity connection for the compensation winding. Otherwise, the total CM noise is increased. This corresponds with our expectations from the previous analysis.

Fig. 8 shows the CM noise current spectrum for the transient simulation results of Fig. 7(a). We can see that the CM noise current is decreased by almost 50 dB in the MHz frequency region. The low frequency region shows a difference of about 7 dB because the steady-state value of the displacement current of the with-compensation winding structure is increased by the additional capacitance between the compensation winding and the secondary winding. The simulation result verifies that the proposed passive noise cancellation method can effectively reduce CM noise.

V. MEASUREMENT RESULTS

A prototype circuit was designed for consumer electronic applications and measured to observe the effects of the proposed method in real applications.

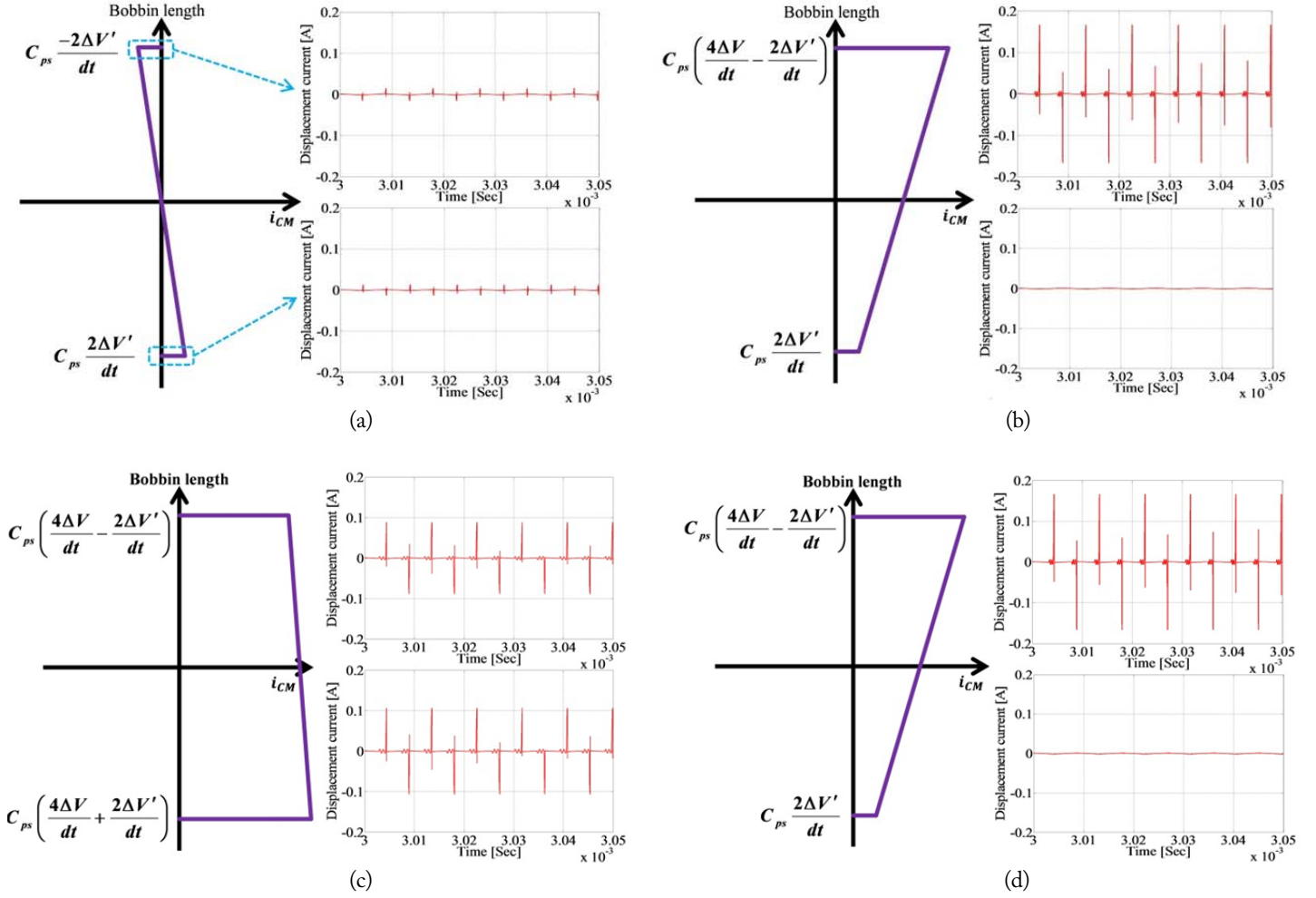

Fig. 6. Comparison between the analysis and simulation results of the displacement currents on the noisy and quiet nodes. (a) Quiet node and anti-polarity connection. (b) Quiet node and same-polarity connection. (c) Noisy node and anti-polarity connection. (d) Noisy node and same-polarity connection.

Figs. 9 and 10 show the measurement setup and the circuit diagram with measuring points. An isolating transformer was used to achieve a floating ground because the AC power input should be protected from possible CM and DM noise. Power can then be supplied to all the devices by connecting them to the isolating transformer. The prototype DC-DC LLC resonant converter with two transformers converts 400 V input to 24–6.5 A and 12–3.5 A dual-output, and the load current is controlled by the electronic load. The 3.5 V DC power supply is for the converter's on-off switch. We can measure and extract the returned noise by using the line impedance stabilization network (LISN), as shown in Fig. 10. The CM and DM noises that are extracted by the LISN can be separated through the EMI analyzer. We can then observe the CM noise with the spectrum analyzer.

Fig. 11 shows the designed prototype LLC resonant converter. The input and output lines are indicated in the figure, and the lines are connected to other devices as shown in Figs.

9 and 10. The quiet node and anti-polarity method are used in the transformer to connect the compensation winding to the primary winding as shown in the circuit diagram in Fig. 10.

The measured CM noise voltage spectrums are shown in Fig. 12. Compared to the original converter, employing the compensation winding reduces CM noise by 10–20 dB in the frequency range of 1–7 MHz. Since the measurement result is for the voltage spectrum, it can be related to the simulation's current spectrum in Fig. 8 by the impedance of the CM noise path. The measurement result shows smaller attenuation than in the simulation, because there are other contributions to the total conducted emission that cannot be eliminated by the proposed method. For example, emission through the heat sink and coupling between the line patterns in the converter circuit board can be directly conducted to the supply input without passing through the transformer. The effects of the additional noise become more dominant,

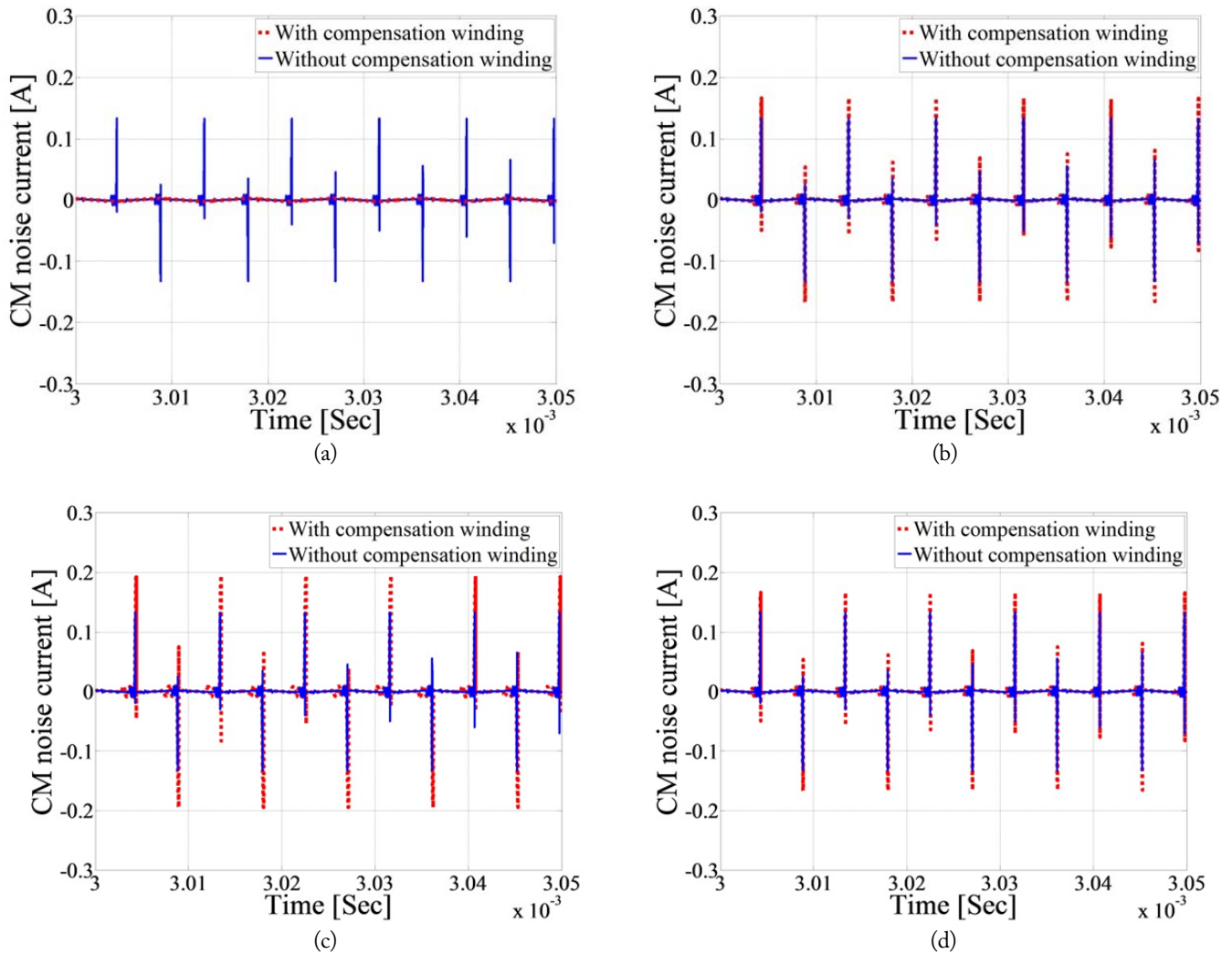

Fig. 7. Simulation results of the total common mode (CM) noise currents after adding the compensation winding. (a) Quiet node and anti-polarity connection. (b) Quiet node and same-polarity connection. (c) Noisy node and anti-polarity connection. (d) Noisy node and same-polarity connection.

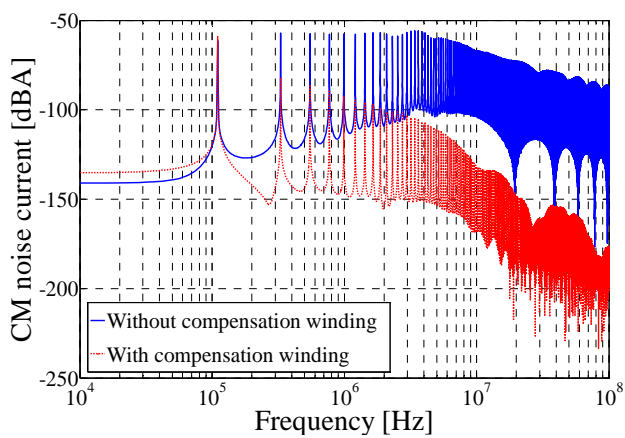

Fig. 8. Comparison of the simulated common mode (CM) noise current spectrums.

especially in the high frequency region, and the proposed method is no longer effective. Nevertheless, both the simu-

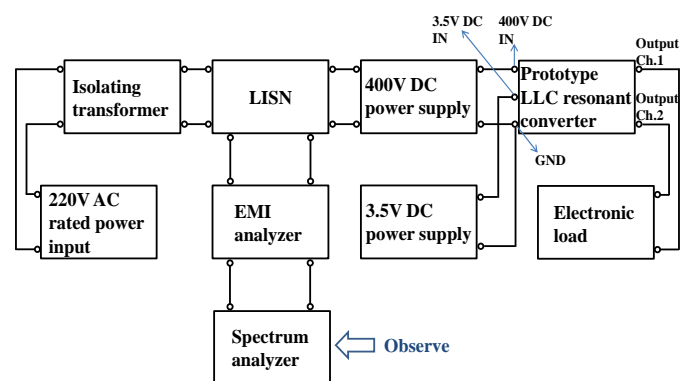

Fig. 9. Measurement setup to observe the common mode (CM) noise. LISN=line impedance stabilization network, LLC=inductor-inductor-capacitor.

lated and measured spectrum results show a correlation indicating that CM noise can be effectively reduced from around

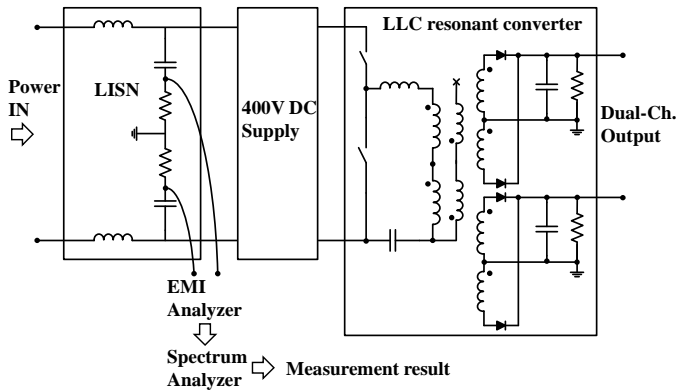

Fig. 10. Circuit diagram and measuring points.

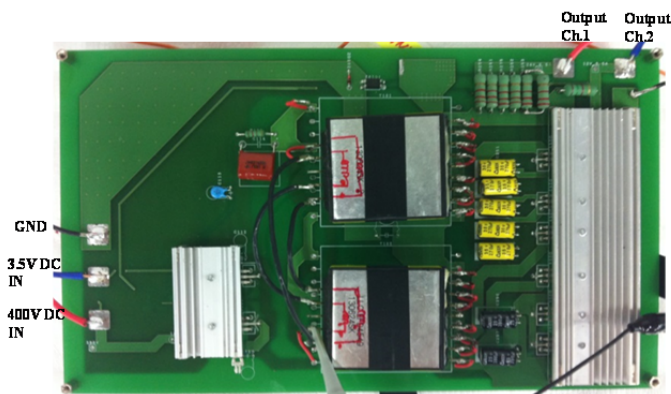

Fig. 11. The designed prototype dual-output half-bridge inductor-in-capacitor (LLC) resonant converter.

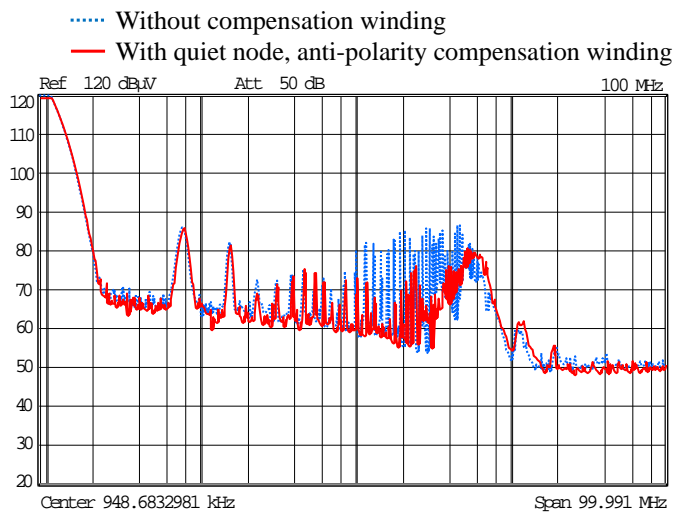

Fig. 12. Measurement results of common mode (CM) noise voltage spectrums.

the MHz frequency region when a significant amount of CM noise occurs in the converter. The measurement result

indicates that the proposed passive cancellation approach is effective for reducing the CM noise of the prototype LLC converters in the frequency range of 1–7 MHz.

VI. CONCLUSION

In this paper, we have examined the passive cancellation method for an LLC resonant converter. To match the parasitic capacitances, the compensation winding should have the same number of turns and a layer arrangement the same as that of the primary winding. Analysis of the displacement current confirmed that the quiet node and anti-polarity connection method using compensation winding is the only effective connection method for reducing CM noise. Use of a properly connected compensation winding reduced the CM noise by up to 20 dB in our frequency range of interest.

This research was supported by the Basic Science Research Program through the National Research Foundation of Korea (NRF) funded by the Ministry of Education (No. 2013R1A1A2009653).

REFERENCES

- [1] D. Cochrane, D. Y. Chen, and D. Boroyevic, "Passive cancellation of common-mode noise in power electronic circuits," *IEEE Transactions on Power Electronics*, vol. 18, no. 3, pp. 756–763, 2003.
- [2] K. S. Babu, M. Borage, S. Tiwari, S. Kotaiah, & R. Saxena, "Analysis and experimentation with passive cancellation of common-mode noise in buck converter," in *Proceedings of the 9th International Conference on Electromagnetic Interference and Compatibility (INCEMIC)*, Bangalore, India, 2006, pp. 172–180.
- [3] Y. P. Chan, B. M. H. Pong, N. K. Poon, and J. C. P. Liu, "Common-mode noise cancellation in switching-mode power supplies using an equipotential transformer modeling technique," *IEEE Transactions on Electromagnetic Compatibility*, vol. 54, no. 3, pp. 594–602, 2012.
- [4] S. De Simone, C. Adragna, and C. Spini, "Design guideline for magnetic integration in LLC resonant converters," in *Proceedings of International Symposium on Power Electronics, Electrical Drives, Automation and Motion (SPEEDAM 2008)*, Ischia, Italy, 2008, pp. 950–957.

Younggon Ryu



received the B.S. degree in electrical engineering from University of Ulsan, Ulsan, Korea, in 2008. He is currently working toward the Ph.D. degree with the School of Electrical and Computer Engineering, Ulsan National Institute of Science and Technology, Ulsan, Korea. His research interests include high frequency modeling and design for electrical machines.

Duil Kim



received his B.S. degree in electrical and computer engineering from Kookmin University in 2003 and M.S. degree in electrical and computer engineering from Hanyang University of Korea in 2005. He is currently working for LG Electronics as a power electronics engineer. His research fields of interests include power electronics, thermal engineering and EMC for TV, Solar power circuit.

Sungnam Kim

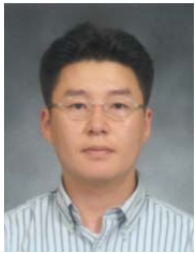

received his B.S. and M.S. degrees in electrical and computer engineering from University of Seoul, Seoul, Korea, in 2003 and 2005, respectively. He is currently working for LG Electronics, Pyeongtaek, Korea, since 2005 as a chief research engineer. His research areas include SI/PI/EMI, ESD, antenna and RF devices. Currently, his research includes EMC on power electronics components of electric vehicle.

Joungwook Park



received his B.S. and M.S. degrees in material science and engineering from Ajou University, Suwon, Korea, in 1991 and 1994, respectively. He is currently working for LG Electronics, Pyeongtaek, Korea, since 1994 as a principal research engineer. His research fields of interests include EMI/EMC, thermal engineering. His current research interests include electronic packaging, embedded RLC on mobile phone.

Geunseok Jeong



received his B.S. and M.S. degrees in electrical and computer engineering from University of Seoul, Seoul, Korea, in 2003 and 2005, respectively. From 2005 to 2012, he was in Electronic Warfare Laboratory of LIGNex1, Seongnam, Korea, as a RF and Antenna engineer. In December 2012, he joined the Production engineering Research Institute at the LG Electronics, Pyeongtaek, Korea, where he is currently a

senior engineer. His current research interests include RF, Antenna, EMC and Power Supply Unit.

Jingook Kim



received his B.S., M.S., and Ph.D. degrees in electrical engineering from Korea Advanced Institute of Science and Technology (KAIST), Daejeon, Korea, in 2000, 2002, and 2006, respectively. From 2006 to 2008, he was with DRAM design team in Memory Division of Samsung Electronics, Hwasung, Korea, as a senior engineer. From January 2009 to July 2011, he worked for the EMC Laboratory at the Missouri University of Science and Technology, Missouri, USA. In July 2011, he joined the Ulsan National Institute of Science and Technology (UNIST), Ulsan, Korea, where he is currently an Assistant Professor. His current research interests include high-speed I/O circuits design, 3D-IC, EMC, ESD, RF interference.

Jaesu Park



received his B.S., M.S., and Ph.D. degrees in electronics and computer engineering from Hanyang University, Seoul, Korea, in 1996, 1998, and 2014, respectively. He is currently working for LG Electronics, Pyeongtaek, Korea, since 1998 as a principal research engineer. His research areas include SI/PI/EMI, ESD, antenna and RF devices. Currently, his research includes EMC on electric vehicle, LED/solar

powers and TV products.

Ki Jin Han



received the B.S. and M.S. degrees in electrical engineering from Seoul National University, Seoul, Korea, in 1998 and 2000, respectively, and the Ph.D. degree in electrical and computer engineering from the Georgia Institute of Technology, Atlanta, GA, USA, in 2009. He was with the System Research and Development Laboratory, LG Precision Co., Ltd., Yongin, Korea, from 2000 to 2005. From 2009 to 2011, he was with the IBM Thomas J. Watson Research Center, Yorktown Heights, NY, USA, from 2009 to 2011, as a Post-Doctoral Researcher. He is currently with the School of Electrical and Computer Engineering, Ulsan National Institute of Science and Technology, Ulsan, Korea, as an Assistant Professor. His current research interests include computational electromagnetics, signal/power integrity for high-speed digital design, microwave circuits, antennas, and electromagnetic modeling of electronic packaging and interconnections.