

초전도 한류기 적용시 배전계통의 신뢰도 비용 평가

Reliability Cost Evaluation of Power Distribution System with Superconducting Fault Current Limiter

문 중 필[†]
(Jong-Fil Moon)

Abstract - In this paper, the effects of superconducting fault current limiter (SFCL) installed in power distribution system on reliability are evaluated and analyzed. The fault current will be decreased in power distribution system with SFCL because of the increased impedance of SFCL. The decreased fault current will improve the voltage drop of the bus of substation. The voltage drop is an important factor of power distribution system reliability. In this paper, improvement of reliability worth is analyzed when SFCLs are installed at the starting point in power distribution system. First, resistor-type SFCL model is used in PSCAD/EMTDC. Next, typical power distribution system is modeled. Finally, when the SFCLs with impedance 0.5 [Ω] are installed in feeder, power distribution system reliability is evaluated. Also, the improvement effect of reliability worth including the effect of voltage sag is analyzed using customer interruption cost according to whether or not SFCL is installed.

Key Words : Customer interruption cost, Power distribution system, SFCL, Voltage sag

1. Introduction

Superconductivity fault current limiter (SFCL) have been developed and applied to the substation of power distribution system in Korea. The circuit breakers don't have to be exchanged to the breakers of bigger capacity because SFCL can limit the fault current to the desired level. Furthermore, SFCL can improve the voltage sag of power distribution system by reducing the fault current when a fault is occurred[1-3].

Several papers on voltage sag and SFCL have been studied. The evaluation method on voltage sags in radial and loop power distribution system with SFCL was studied in [1] and [2]. The improvement of voltage sag by SFCLs installed in the various locations of radial distribution system was studied in [3-5].

In general, the customer interruption costs (CIC) are caused by an interruption at customers. The interruptions are caused by the faults such as permanent faults and temporary faults. Also, the interruptions can be caused by trip of loads by voltage sags.

In this paper, reliability worth, especially CICs, are evaluated in power distribution system with and without SFCL including the effects of voltage sags. In section II,

the components of power distribution system such as SFCL, line, main transformer, and critical loads are modeled. In section III, CICs are evaluated including the effects of the sustained and the temporary interruptions and the voltage sags.

2. Power Distribution System Modeling

2.1 SFCL

A resistive-type SFCL is used as in (1) in this paper [1, 2, 6-8].

$$R(t) = \begin{cases} 0 & (t < t_0) \\ R_n [1 - \exp(-(t-t_0)/T_F)]^{1/2} & (t_0 \leq t < t_1) \\ a_1(t-t_1) + b_1 & (t_1 \leq t < t_2) \\ a_2(t-t_2) + b_2 & (t \geq t_2) \end{cases} \quad (1)$$

Table 1 represents the values of parameters in Eq. (1).

Table 1 Parameters of SFCL

Parameter	Rn[Ω]	TF	a1[1/s]	a2[1/s]	b1[Ω]	b2[Ω]
Value	0.5	0.01	-80	-160	Rn	Rn/2

2.2 Power Distribution System

Simple power distribution system is modeled as Fig. 1. The modeled system has one main transformer, two feeders, four load points (LP), and circuit breakers with overcurrent relay (OCR), and reclosers. Two feeders are

[†] 교신저자 : 한국교통대 전기공학과 부교수 · 공박

E-mail : moon@ut.ac.kr

접수일자 : 2014년 11월 4일

수정일자 : 2014년 11월 25일

최종완료 : 2014년 11월 26일

interconnected by the normally opened switch to interconnect the feeders when a fault occurred. Also, SFCLs are located in the starting points of feeders. The voltages of the primary side and secondary side are 154 kV and 22.9 kV, respectively. Tables 2-5 represent the data related to the modeled power distribution system.

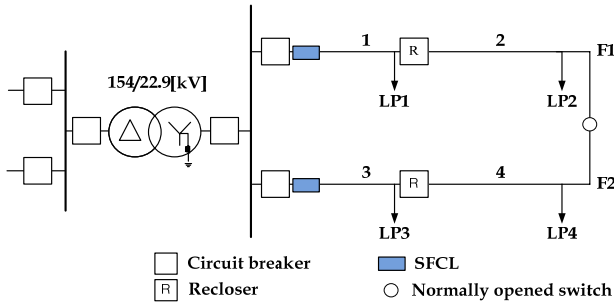

Fig. 1 Power distribution system model

Table 2 Parameters of Power Distribution System

Type	Impedance
Source	154[kV], $Z_1 = j4[\Omega]$, 100[MVA]
Main Tr.	154/22.9[kV], $Z_1 = j15[\%]$, 45[MVA]
Line	$Z_1 = 3.86 + j7.43[\% / km]$

Table 3 Data of Failure Rate and Repair Time

Type	Permanent fault		Temporary fault
	Failure rate	Repair time	Failure rate
Line	0.01 [/km]	2 [hour]	0.045 [/km]

Table 4 Data of Line Length

Line	Length [km]
1	3
2	2
3	4
4	5

Table 5 Data of the Type of Customers and Mean Load

Load point	Type of customers	Load [kW]
1	Residential	2,000
2	Industrial	4,000
3	Office building	3,000
4	Commercial	1,500

Fig. 2 represents the data of customer interruption cost according to the type of customers investigated by Canada[9].

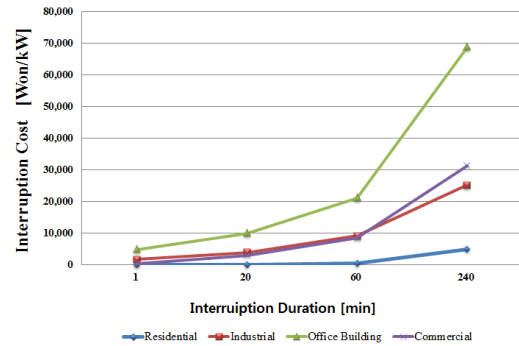

Fig. 2 Customer interruption cost according to the type of customers

3. Evaluation of Customer Interruption Cost

3.1 Voltage Sags and Interruption Occurrence Mechanism

In Fig. 1, if a permanent fault is occurred in line 2, the recloser in upstream side of line 2 is opened to eliminate the fault according to fast and delayed inverse - time curve and the recloser is closed to distinguish between permanent fault and temporary fault after an interval. In the end, the recloser is locked out because the fault is permanent. During the reclosing process, LP1, 3, and 4 experience voltage sags. Also, LP2 experiences the sustained interruption until the fault is restored. Table 6 represents the voltage sag and interruption experienced by customers according to the types of faults.

Table 6 Voltage Sag and Interruption Experienced by Customers

Fault type	Faulted feeder	Neighbor feeder
Permanent fault	Sustained Interruption / voltage sag	Voltage sag
Temporary fault	Temporary Interruption /voltage sag	Voltage sag

The identity of voltage sag can be evaluated by magnitude and duration. The magnitude of voltage sag can be calculated by fault study. The magnitude is generally improved by SFCL because of the reduced fault current. The duration of voltages sag can be calculated by trip time of OCR and recloser. If a fault is occurred in line 1 or 3, the delay trip time of OCR is the duration of voltage sag. On the contrary, the delay trip time of recloser is the duration for faults of line 2 or 4. Eq. (2) and (3) represent the delay trip time of OCR and recloser used in this paper, respectively.

$$T_{OD} = \left(\frac{39.85}{I^{1.95} - 1} + 1.084 \right) \times 6 \times 4.4 \quad (2)$$

$$T_{RD} = 1.075 \times I^{-1.5394} \quad (3)$$

3.2 ITIC and Critical Loads

If the voltage sag is occurred, the critical loads may be tripped. The trip can cause the CIC, for example, the synchronous motor connected to magnetic contactor (M/C) is interrupted by the tripped M/C.

In this paper, five critical loads are used such as adjustable speed drive (ASD), High intensity discharge (HID), M/C, PC, automatic voltage regulator (AVR).

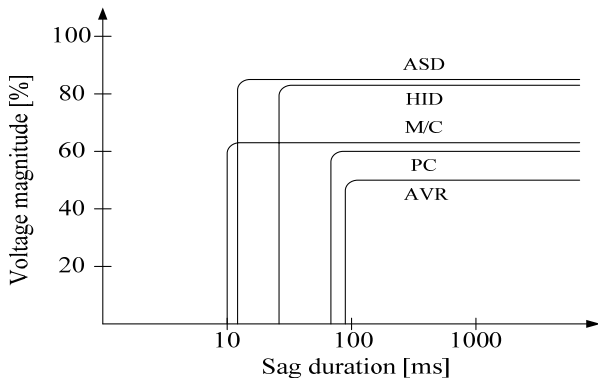

Fig. 3 ITIC for critical loads

The used Information of Technology Industry Council (ITIC) curves are shown in Fig. 3[10]. The outside of ITIC curves denotes the safety area for voltage sag. On the contrary, the inside of ITIC represents the tripped area of each load.

Table 7 is the data of critical loads ratio according to the types of customers[10].

Table 7 Critical Loads Ratio according to the Types of Customers [%]

Load type	Res.	Ind.	Off.	Com.
HID Lamp	10	14.7	20.7	23
Motor (M/C)	0	52.6	11.9	0
Motor (ASD)	0	4.4	36	5
PC	3	1.7	8.6	7
AVR	0	0.4	0.31	0

3.3 CIC evaluation

The processes of CIC evaluation are as follows.

1. Evaluation of sustained interruption by permanent fault
 - Step 1) Searching the LPs experiencing sustained interruption by permanent fault of each line.

- Step 2) Calculating failure rate, repair time, and unavailability of LPs

- Step 3) Calculating CIC by sustained interruption of permanent fault

2. Evaluation of temporary interruption by temporary fault

- Step 4) Searching the LPs experiencing temporary interruption by temporary fault of each line.

- Step 5) Calculating failure rate, repair time, and unavailability of LPs

- Step 6) Calculating CIC by temporary interruption of temporary fault

Table 8 represents the CIC caused by the sustained interruption and the temporary interruption

Table 8 CIC by Sustained and Temporary Interruption [Won/year]

LP	CIC by sustained interruption	CIC by temporary interruption
1	117,560	9,763
2	1,776,137	1,887,489
3	4,438,000	3,159,909
4	1,472,485	802,252
Total	7,804,182	5,859,413

3. Evaluation of voltage sag by permanent fault

- Step 7) Searching the LPs experiencing voltage sag by permanent fault of each line.

- Step 8) Calculating the magnitude and duration of sag experienced by LPs using fault study and eq. (2) and (3).

- Step 9) Searching the critical loads tripped by the voltage sag using ITIC curve in Fig. 3.

The restoration time of loads tripped by voltage sag is assumed to 5 min.

- Step 10) Calculating CIC by voltage sag using Table 5, 7, and Fig. 2

4. Evaluation of voltage sag by temporary fault

- Step 11) Searching the LPs experiencing voltage sag by temporary fault of each line.

- Step 12) Calculating the magnitude and duration of sag experienced by LPs using fault study and eq. (2) and (3).

- Step 13) Searching the critical loads tripped by the voltage sag using ITIC curve in Fig. 3.

- Step 14) Calculating CIC by voltage sag using Table 5, 7, and Fig. 2.

5. Repeating step 7) to step 14) for power distribution system with SFCL of 0.5 [Ω].

Table 9 represents the magnitude and duration of voltage sag in power distribution system with and without SFCLs through fault study. Table 10 represents the tripped critical loads in distribution system with and without SFCL. In Table 10, T means that the critical load is tripped and X means the critical load is not tripped. Also, Δ means that the load is tripped in case of system without SFCL, however the load is not tripped in case of system with SFCL.

Fig. 4 represents the CIC caused by voltage sag by permanent and temporary fault in power distribution system with and without SFCLs for all LPs. In Fig. 4, CICs by voltage sags are decreased in case that SFCLs are installed compared with case that SFCLs are not installed because the resistance of SFCLs decreases the

Table 9 Magnitude and Duration of Voltage Sag

SFCL	Faulted Component	Line 1	Line 2	Line 3	Line 4
Without SFCL	V of LP1 [%]	0.0	11.3	24.7	59.0
	V of LP2 [%]	0.0	0.0	24.5	58.5
	V of LP3 [%]	21.3	48.9	0.0	19.3
	V of LP4 [%]	21.1	48.4	0.0	0.0
	If [kA]	5.745	3.805	5.473	3.037
	Duration [ms]	623	954	631	1130
With SFCL	V of LP1 [%]	0.0	21.6	54.8	70.7
	V of LP2 [%]	0.0	0.0	54.3	70.0
	V of LP3 [%]	49.6	59.6	0.0	37.4
	V of LP4 [%]	49.1	59.0	0.0	0.0
	If [kA]	5.443	3.628	5.191	2.910
	Duration [ms]	632	988	641	1168

Table 10 Tripped Critical Loads

LP	Faulted comp.	HID	M/C	ASD	PC	AVR
1	Line1	X	X	X	X	X
	Line2	T	T	T	T	T
	Line3	T	T	T	T	Δ
	Line4	T	Δ	T	Δ	X
2	Line1	X	X	X	X	X
	Line2	X	X	X	X	X
	Line3	T	T	T	T	Δ
	Line4	T	Δ	T	Δ	X
3	Line1	T	T	T	T	T
	Line2	T	T	T	T	Δ
	Line3	X	X	X	X	X
	Line4	T	T	T	T	X
4	Line1	T	T	T	T	T
	Line2	T	T	T	T	Δ
	Line3	X	X	X	X	X
	Line4	X	X	X	X	X

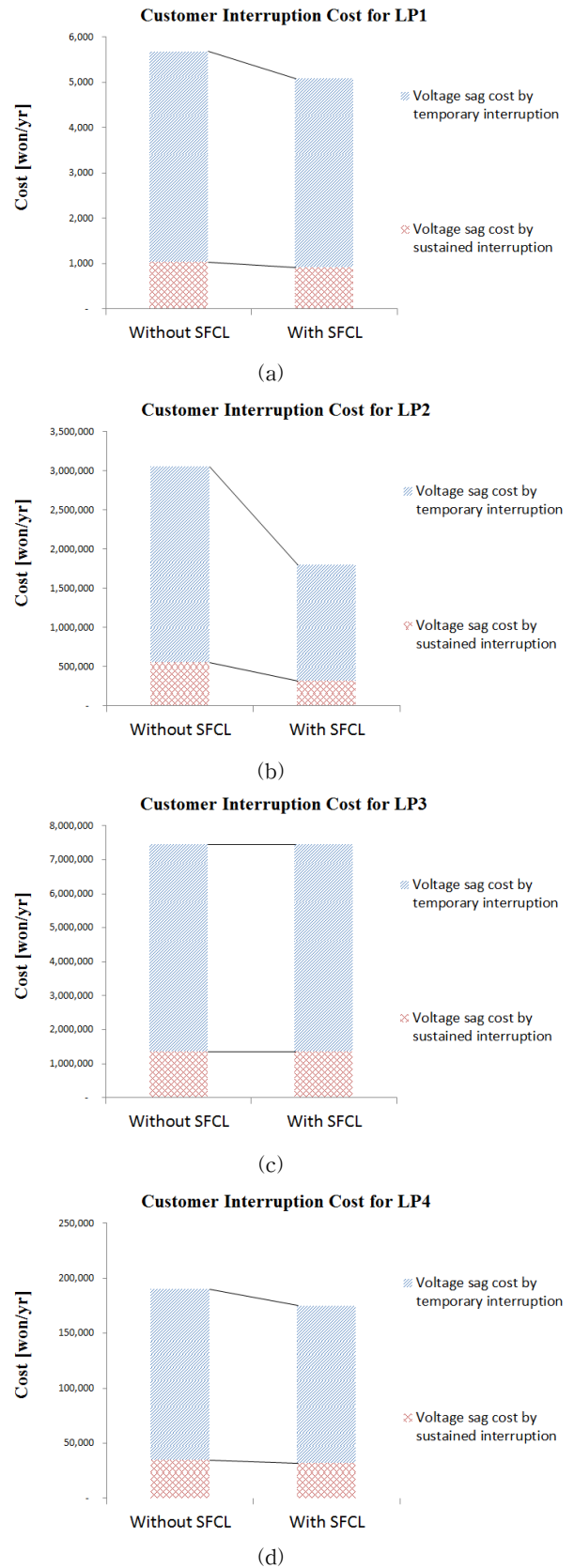

Fig. 4 CIC caused by voltage sags by permanent and temporary faults in system with and without SFCLs for each LP: (a) LP1, (b) LP2, (c) LP3, (d) LP 4

fault current and the magnitude of voltage sag is improved.

4. Conclusions

In this paper, the reliability worth, CIC, is evaluated caused by interruptions. The interruptions can be caused by permanent fault, temporary fault, and voltage sags. CIC caused by sustained interruption by permanent fault and temporary interruption by temporary fault is not changed regardless of installation of SFCLs. However, the CIC caused by voltage sag is decreased if the SFCLs are installed, because SFCL can reduce the fault current and the magnitude of voltage sag is improved.

The CIC by voltage sag, 1,275,842 [Won], is decreased in simple power distribution system model used in this paper. If SFCLs are installed in many location of power distribution system, a lot of CICs are decreased. Also, if the SFCLs with the resistance bigger than 0.5 Ω are installed, the CIC are improved more.

감사의 글

이 논문은 2011년 정부(교육부)의 재원으로 한국연구재단의 기초연구사업 지원을 받아 수행된 것임. (2011-0013024)

References

[1] J.-F. Moon, S.-H. Lim, J.-C. Kim, and S.-Y. Yun, "Assessment of the impact of SFCL on voltage sags in power distribution system," *IEEE Trans. Appl. Supercond.*, vol. 21, no. 3, pp. 2161 - 2164, Jun. 2011.

[2] J.-F. Moon, J.-S. Kim, "Voltage Sag Analysis in Loop Power Distribution System with SFCL," *IEEE Trans. Appl. Supercond.*, vol. 23, no. 3, Jun. 2013.

[3] Lin Ye, LiangZhen Lin, and Klaus-Peter Juengst, "Application Studies of Superconducting Fault Current Limiters in Electric Power Systems," *IEEE Trans. on Applied Superconductivity*, Vol. 12, No. 1, March 2002.

[4] J. C. Das, "Limitations of Fault-Current Limiters for Expansion of Electrical Distribution Systems," *IEEE Trans. on Industry Application*, Vol. 33, No. 4, July/Aug. 1997.

[5] Fabio Tosato and Stefano Quaia, "Reducing Voltage Sags Through Fault Current Limitation," *IEEE Trans. on Power Delivery*, Vol. 16, No. 1, Jan. 2001.

[6] S. H. Lim, S. R. Lee, H. S. Choi, and B. S. Han, "Analysis of operational characteristics of flux-lock type SFCL combined with power compensator," *IEEE Trans. Appl. Supercond.*, vol. 15, no. 2, pp. 131-134,

June 2005.

[7] H. R. Kim, S. W. Yim, S. Y. Oh, and O. B. Hyun, "Recovery in Superconducting Fault Current Limiters at Low Applied Voltages," *IEEE Trans. Appl. Supercond.*, vol. 18, no. 2, pp. 656-659, June 2008.

[8] H.-R. Kim, S.-W. Yim, S.-Y. Oh, and O.-B. Hyun, "Analysis on recovery in Au/YBCO thin film meander lines," *Progress Supercond.*, vol. 9, no. 1, pp. 119 - 125, 2007.

[9] G. Toefson, R. Billinton, G. Wacker, et. al, "A Canadian Customer survey to Assess Power System Reliability Worth," *IEEE Trans. on Power Systems*, vol. 9, no. 1, pp. 443-450, 1991.

[10] H.-T. Lee, J.-F. Moon, K.-H. Seol, et. al, "Evaluation of Reliability Worth considering Sustained Interruptions and Voltage Sags," *Journal of KIIEE*, vol. 22, no. 5, pp. 13-20, May 2008.

저 자 소 개



문 종 필 (文鍾必)

1977년 5월 27일생. 2000년 숭실대 전기공학과 졸업. 2007년 동 대학원 전기공학과 졸업(공학박사). 2009년~현재 한국교통대학교 전기공학과 부교수

Tel : 043-841-5146

Fax : 043-841-5140

E-mail : moon@ut.ac.kr