



Hydraulic Evaluation and Performance of On-Site Sanitation Systems in Central Thailand

Thammarat Koottatep^{1†}, Rawintra Eamrat¹, Tatchai Pussayanavin¹, Chongrak Polprasert²

¹Environmental Engineering and Management, School of Environment Resources and Development, Asian Institute of Technology, Pathumthani 12120, Thailand

²Department of Civil Engineering, Faculty of Engineering, Thammasat University, Pathumthani 12120, Thailand

ABSTRACT

On-site sanitation systems are typically installed to treat grey and toilet wastewaters in areas without sewer and centralized treatment systems. It is well known that, due to inappropriate design and operation, treatment performance of these systems in developing countries is not satisfactory in the removal of pathogens and organic matters. This research aimed to investigate the hydraulic conditions occurring in some on-site sanitation systems and the effects of hydraulic retention times (HRTs) on the system performance. The experiments were conducted with a laboratory-scale septic tank (40L in size) and an actual septic tank (600L in size), to test the hydraulic conditions by using tracer study with HRTs varying at 12, 24 and 48 hr. The experimental results showed the dispersion numbers to be in the range of 0.017-0.320 and the short-circuit ratios in the range of 0.014-0.031, indicating the reactors having a high level of short-circuiting and approaching complete-mix conditions. The removal efficiency of BOD₅ was found to be 67% and the k₃₀ values for BOD₅ was 2.04 day⁻¹. A modified complete-mix model based on the relationship between BOD₅ removal efficiencies and HRTs was developed and validated with actual-scale septic tank data having a correlation coefficient (R²) of 0.90. Therefore, to better protect our environment and minimizing health risks, new generation toilets should be developed that could minimize short-circuiting and improving treatment performance.

Keywords: Hydraulic conditions, Hydraulic retention time, On-site sanitation, Septic tanks, Treatment performance

1. Introduction

Up to present, there are approximately 2.7 billion people without access to basic sanitation. For example, the Sub-Saharan Africa has unsafe water and lacking sanitation that can kill children less than 5 years about 1.6 million per year [1]. Better management of the sanitation is to use on-site sanitation systems to solve this problem. On-site sanitation technologies such as cesspools, two cesspools in series and septic tanks are commonly used to treat domestic wastewater in developing countries. However, treatment performance of these septic tanks is not satisfactory in removal of pathogens and organic matters due to inappropriate design and operation. A previous study found that septic tank could reduce organic matter, nutrient and pathogens only 20%-50% [2]. Effluent concentrations of septic tanks were found to contain BOD₅ of 90-160 mg/L and fecal coliforms of 10⁵-10⁸ MPN/100 mL [3], higher than the standards for discharge and causing water pollution and high health risk. Main factors affecting the treatment performance of septic tanks were the flow patterns or hydraulic characteristics.

The hydraulic conditions have high influence on the treatment performance of reactors and are commonly used to design various reactors. Thus, optimizing reactor configurations and flow rate are important for septic tank designs.

Objectives

The purpose of this study was to evaluate the hydraulic conditions and performance of on-site sanitation systems in central Thailand. The specific objectives of the presents study were:

- To investigate the hydraulic conditions occurring in on-site sanitation systems and the effect of hydraulic retention times (HRTs) on the system performance.
- To evaluate the treatment performance of laboratory-scale and actual-scale septic tanks in term of organic biodegradation and pathogen removals.
- To develop a kinetic model for septic tanks for use in design and operation.



This is an Open Access article distributed under the terms of the Creative Commons Attribution Non-Commercial License (<http://creativecommons.org/licenses/by-nc/3.0/>) which permits unrestricted non-commercial use, distribution, and reproduction in any medium, provided the original work is properly cited.

Copyright © 2014 Korean Society of Environmental Engineers

Received May 27, 2014 Accepted August 26, 2014

† Corresponding author

E-mail: thammaratkoottatep@gmail.com

Tel: +66-2-524-6188 Fax: +66-2-524-5625

2. Materials and Methods

2.1. Reactor Preparation

The experiments set up at the Asian Institute of Technology (AIT), Environmental Engineering Research Station, Pathumthani Province, Thailand, were conducted with two rectangular septic tanks (40 L in size, laboratory-scale) and a circular septic tank (600 L in size, actual-scale). The laboratory-scale reactors were made of acrylic sheet with a dimension of 56×25×40 cm (length×width×height) with the level of water of 28.5 cm, as shown in Fig. 1(a). The actual septic tank was made of acrylonitrile butadiene styrene (ABS) plastic with a diameter of 0.95 m and height of 1.04 m, as shown in Fig. 1(b).

2.2. Tracer Study

Tracer study was used to evaluate the hydraulic conditions of the rectangular septic tank and the circular septic tank by continuously feeding tap water at different flow rates to maintain the HRTs at 12, 24 and 48 hr. Due to limitation of the configuration of the tanks and flow effects, this study used two types of tracer chemicals such as NaCl and Rhodamine dye. A single pulse of the tracer chemical was fed at the influent and concentrations of the tracer at the effluent of the rectangular and circular septic tanks were measured. For NaCl, the effluent concentrations were

measured with a conductivity meter (Mettler Toledo LE703 conductivity, Switzerland) after calibrating with 0.1 N KCl solutions. For Rhodamine dye, the effluent concentrations were measured with a fluorometer at the optimum excitation of 556 nm and optimum emission wavelength of 580 nm (Bio-Tek Synergy 2 SLF (2011) Multi-Mode Microplate Reader, USA). The effluent samples were collected about once an hour until the tracer concentrations reached the background level.

The results were determined according to the normalized residence time distribution (RTD) curves by plotting graph between t/T and C_i/C_0 according to Levenspiel [4].

The mean residence time or actual hydraulic retention time (\bar{t}) was calculated by Eq. (1):

$$\bar{t} = \frac{\int_0^\alpha t C dt}{\int_0^\alpha C dt} \cong \frac{\sum_i t_i c_i \Delta t_i}{\sum_i c_i \Delta t_i} = \frac{V}{v} \quad (1)$$

Dead space or dead zone is the dead zone of reactor which affects the overall treatment efficiency because volume of this zone is unavailable to the main flow and was calculated by Eq. (2):

$$\frac{V_d}{V_i} = 1 - \bar{t} \quad (2)$$

Short-circuiting is a portion of first appearance of tracer at the effluent and design HRTs ($HRT = V/Q$). If this value is less than acceptable range of short-circuiting of 0.3 or 0.4 short-circuiting will occur. This value was calculated by Eq. (3):

$$\psi = \frac{t_k}{t} \quad (3)$$

where t_k is time of first appearance of tracer at the effluent

Dispersion number ($\frac{D}{uL}$) was evaluated by recording the shape of the tracer curves as it passes the exit of the system and measured by mean time of passage \bar{t} and variance, or a measure of the spread of the curve σ^2 . The dispersion number 0 means no dispersion or ideal plug flows, while the infinity value indicates complete-mix [5]. The dispersion number was calculated by Eq. (4):

$$\sigma_\theta^2 = \frac{\sigma_t^2}{\bar{t}^2} = 2 \left[\frac{D}{uL} \right] \quad (4)$$

where D is coefficient of axial dispersion (L^2/T).

2.3. Performance Study

Although under actual conditions the flow of toilet wastewater is intermittent, in this study the rectangular septic tanks was fed with a black water (or toilet wastewater) at an average flow rate of 1.67 L/hr or an organic loading rate of 1.7 kg COD/m³day to maintain the HRT value of 24 hr. The reactor temperatures were controlled at 30°C and 40°C by placing the reactor in heated water. The effluent samples were collected and analyzed for physical,

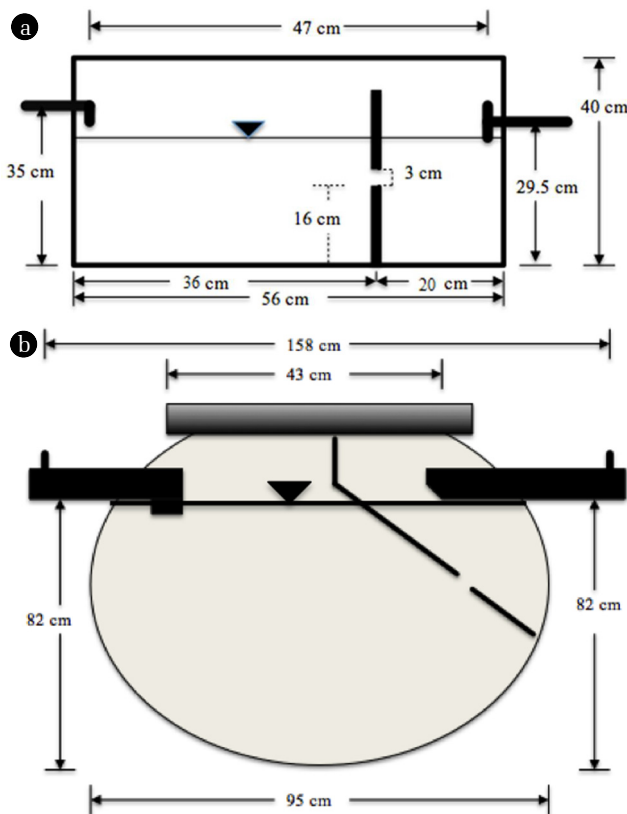

Fig. 1. Details of reactors: (a) laboratory-scale septic tank and (b) actual-scale septic tank.

Table 1. Parameter and Method of Analysis

Parameter	Unit	Methods of analysis
Total solids (TS)	mg/L	Evaporation at 105°C
Total volatile solids (TVS)	mg/L	Evaporation and burning at 550°C
TCOD	mg/L	Closed dichromate reflux
BOD ₅	mg/L	Azide Modification
Fecal coliforms	MPN/100 mL	Multiple-tube fermentation technique

**Fig. 2.** Types of on-site sanitation (a) one cesspool, (b) two cesspools in series, (c) three cesspools in series, (d) commercial package.

chemical and biological characteristics such as TCOD, BOD₅, TS, TVS and fecal coliforms.

2.4. Field Survey in Central Thailand

Field survey of on-site sanitation systems of 38 households in central Thailand such as Pathumthani and Nonthaburi provinces were observed for about 6 months. There are four types of on-site sanitation systems, which are mostly used for treating toilet wastewater such as one cesspool (about 10 households), two cesspool in series (about 8 households), three cesspool in series (about 6 households) and commercial packages or septic tanks (about 14 households) as shown in the Fig. 2.

The HRTs of these on site sanitation systems were found to be in the range of 5-16 days. The influent and effluent samples were collected by grab sampling and analyzed for physical, chemical and biological characteristics according to Standard Methods [6] as shown in Table 1.

3. Results and Discussion

3.1. Tracer Study

The hydraulic characteristics or RTD curves of the laboratory-scale and actual-scale septic tanks at HRTs of 12, 24 and 48 hr are shown in Fig. 3.

All the RTD curves of the actual-scale and laboratory-scale septic tanks had similar trend approaching complete-mix conditions. The dispersion numbers of these HRTs values was found to be 0.17-0.32 which were within moderate to high dispersion ranges and HRTs did not appear to show any significant effects on the dispersion numbers. The short-circuit ratios (time of first appearance of tracer at the effluent and designed HRTs) were found in the range of 0.014-0.031, indicating a high degree of short-circuiting, which were not in the acceptable range of 0.3-0.4 [7]. The mean HRTs or actual HRTs were found lower than designed HRTs

Table 2. Tracer Study Results

Value	Unit	Actual-scale septic tank			Laboratory -scale septic tank		
		HRT 12 hr	HRT 24 hr	HRT 48 hr	HRT 12 hr	HRT 24 hr	HRT 48 hr
\bar{t}	hr	7.9	15.7	43.5	11.0	21.3	33.8
σ^2	hr ²	21.7	103.2	824.6	57.6	167.8	623.5
σ_θ^2	hr ²	0.34	0.41	0.44	0.47	0.64	0.55
$\frac{D}{uL}$	-	0.17	0.21	0.22	0.24	0.32	0.27
Dead space	%	34	35	10	8	34	30
Short-Circuiting	-	0.014	0.031	0.016	0.014	0.020	0.021
Mass recovery	%	77	70	75	94	98	100

: mean or actual hydraulic retention time, : variance or the spread of the curve, D: dispersion coefficient, L: length. : velocity of water.

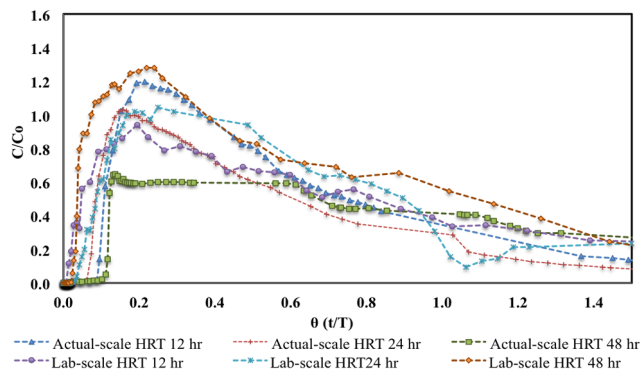

Fig. 3. RTd curves of dispersion in septic tanks.

of 12, 24 and 48 hr, and suggesting the prevalence of complete-mix conditions. Thus, it could be summarized from these tracer data that the hydraulic conditions occurring in the above on-site sanitation systems operating at the HRTs values of 12-48 hr (which are usually employed for most of these systems) are complete-mix. The results of tracer analysis are summarized in Table 2.

Because the results of the two types of on-site sanitation systems had similar trend, approaching complete-mix conditions, for simplification in design, Eq. (5) could be applied

$$\frac{c}{c_0} = \frac{1}{1 + k_T \cdot t} \quad (5)$$

Table 3. Treatment Performances of Laboratory-scale Septic Tanks

T (°C)	Condition	Parameter				
		TCOD (mg/L)	BOD ₅ (mg/L)	TS (mg/L)	TVS (mg/L)	Fecal coliforms (MPN/100mL)
30	Influent	1,740±686	410±192	1,480±849	1,350±789	1.00×10 ⁷
	Effluent	480±187	140±50	530±334	410±212	6.34×10 ⁶
	Removal efficiencies (%)	69±14	67±15	62±16	70±15	0.198*
40	Influent	1,740±686	410±192	1,480±849	1,350±789	1.00×10 ⁷
	Effluent	370±160	140±46	430±220	320±152	2.10×10 ⁶
	Removal efficiencies (%)	76±14	67±16	72±13	77±14	0.678*

Values are presented as mean±standard deviation or number.

*: log reduction, TCOD: total chemical oxygen demand, BOD: biochemical oxygen demand, TS: total solids, TVS: total volatile solids, MPN: most probable number.

Where C was effluent concentration, C_0 was initial concentration, k_T is reaction rate coefficient at temperature T (°C) according to Eq. (6) and t was retention time or HRT.

$$k_{20} = k_{20} \theta^{T-20} \quad (6)$$

3.2. Treatment Performance of Laboratory-Scale Septic Tanks

The treatment efficiencies of TCOD, BOD₅, TS, TVS and fecal coliforms of the laboratory-scale septic tanks operating at HRT of 24 hr, during steady state conditions are shown in Table 3. The steady-state conditions were assumed to occur when the removal efficiencies of septic tank effluent from the systems were found to be stable for about 1 week. Due to the high organic content of toilet wastewater, the TVS/TS ratio was about 0.9, similar to those values previously reported in the literature [3]. From the experimental period of 4 months, the percent removal of TCOD, BOD₅, TS and TVS in the laboratory-scale septic tanks operating at 30°C were about 69, 67, 62 and 70 percent, respectively. The fecal coliform concentrations were reduced from 1.0×10⁷ to 6.34×10⁶ MPN/100 mL when the HRT value was maintained at 1 day. For the 40°C operation, the percent removal of TCOD, BOD₅, TS and TVS were about 76%, 67%, 72% and 77%, respectively. The fecal coliform concentrations were reduced from 1.0×10⁷ to 2.1×10⁶ MPN/100 mL when the HRT value was maintained at

1 day. Since the removal mechanism could be mainly due to sedimentation of solids, hence the removal efficiencies of these two laboratory-scale septic tanks were not high and not much different. Accordingly, the k_{30} for BOD₅ removal calculated from Eq. (5) was found to be 2.04 day^{-1} . The k values for BOD₅ removal at other temperatures can be determined from Eq. (6).

However, the k_{40} determined from Eq. (6) could not adequately predict the treatment performance of the laboratory-scale septic tank operating at 40°C. Therefore a modified complete-mix equation was proposed as described in section 3.4.

3.3. Field Survey in Central Thailand

Data of field surveys of the on-site sanitation systems of some households in central Thailand are shown in Table 4. The HRT of these on-site sanitation systems were about 5-16 days and their volumes were found to be 500-1,000 L. Moreover, flow rates of their black water to the on-site sanitation systems excluding grey water were found to be in range of 60–220 L/household/day.

The effluent concentrations of BOD₅ and fecal coliforms were found to be much higher than the Thailand standards for discharge of treated household wastewaters of 20 mg/L and 1000 MPN/100 mL, respectively [8]. These results are similarly to the data of the laboratory-scale septic tanks (Table 3), which revealed unsatisfactory performance and the septic tank effluents need to be further treated. The unsatisfactory results are hypothesized to be due to the hydraulic conditions which caused high degree of short-circuiting as reported earlier, and improper design and operation of these on-site sanitation systems. Moreover, sludge accumulation in the systems also reduced the mean HRTs, resulting in more short-circuiting and increasing the effluent concentrations. It is strongly recommended that post treatment of the septic tank effluents should be done possibly by electrochemical precipitation or nano-disinfection processes which do not required large land area and are cost-effective. More research in this area will be reported later.

3.4. Model Development

The BOD₅ removal data obtained from the laboratory-scale and actual-scale septic tanks were plotted in Fig 4. Based on the relationship between C/C_0 and HRT (day), a correction factor γ was added to Eq. (7) to cover the solubilization effects of organic matter in the sludge layer and other related factors. The modified equation is shown below:

Table 4. Data of Field Survey of On-site Sanitation Systems^a

HRT (day)	Influent (mg/L)					Effluent (mg/L)				
	TCOD	BOD ₅	TS	TVS	Fecal coliforms [*]	TCOD	BOD ₅	TS	TVS	Fecal coliforms [*]
5	2,200±374	1,170±135	2,100±207	1,470±269	4.2×10 ⁶	245±63	180±56	700±65	390±128	1.2×10 ⁶
7	2,920±470	1,780±125	2,480±561	1,230±670	6.8×10 ⁶	190±99	110±53	620±52	360±127	1.6×10 ⁶
9	2,490±437	1,190±107	1,570±373	880±125	9.5×10 ⁶	230±74	65±44	520±122	240±63	1.5×10 ⁶
16	4,110±510	2,200±75	4,075±415	2,880±316	2.2×10 ⁶	120±33	70±20	1,380±36	600±40	8.2×10 ⁵

Values are presented as mean ± standard deviation or number.

^{*}Unit of fecal coliforms was MPN/100 mL, TCOD: total chemical oxygen demand, BOD: biochemical oxygen demand, TS: total solids, TVS: total volatile solids.

^aThese are actual-scale septic tanks (see Figure 1b) whose volumes ranging from 600-1200 L in size.

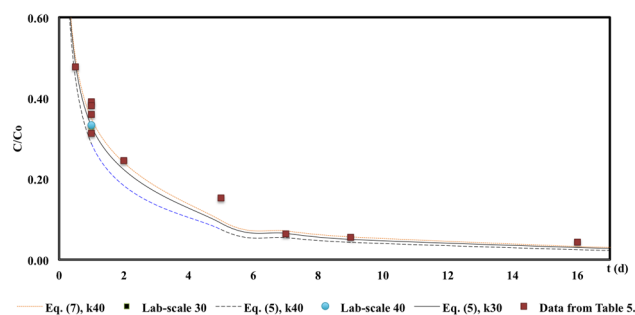

Fig. 4. Modified complete-mix model.

$$\frac{c}{c_0} = \frac{1}{1 + \gamma k_T t} \quad (7)$$

where

$$\gamma = \frac{30}{T} \quad (8)$$

and γ is correction factor, unitless.

From Eq. (7) was validated with the experimental data of this study and also other septic tank data (shown in Table 5) and plotted in Fig. 4. The validation results demonstrated the applicability of the modified complete-mix model with the R^2 value of 0.90. However, it should be noted that Eq. (7) and (8) are applicable for the septic tank operation at temperatures of 30-40°C, and further validation of these two equations with septic tank data of different temperatures is recommended.

3.5. Application of Results

To better protect our environment and safeguard public health, new generation toilets should be developed which should minimize short-circuiting and improving treatment performance. These re-invented toilets should be able to eliminate all pathogens and reducing BOD₅ to meet the effluent discharge standards. Methods to minimize short-circuiting include providing more baffles, better design of inlet and outlet pipes and extending the length/width ratio of the septic tanks. The treatment efficiency could be improved by employing certain enzymes, catalysts or increasing septic tank temperature which should lead to lower effluent BOD₅ and pathogen concentrations.

Table 5. Previous Studies of BOD₅ Removal at Average Temperature at 30

HRT (d)	Co	C	C/Co	% Removal	Reference
0.5	65*	30	0.48	52.31	[9]
1	115*	45	0.39	60.87	[9]
1	400	125	0.31	68.75	[10]
1	625	225	0.36	64.00	[11]
2	625	150	0.24	75.52	[11]
2	196	80	0.42	58.16	[12]
5	1170	180	0.15	84.79	Field survey data
7	1780	110	0.06	93.60	Field survey data
9	1190	65	0.05	94.53	Field survey data
16	2200	95	0.04	95.68	Field survey data

*These were settled toilet wastewater samples.

4. Conclusions

The tracer study reviewed that operation of the laboratory- and actual-scale septic tanks under normal conditions had the hydraulic patterns approaching complete-mixing conditions and a high degree of short-circuiting. For the hydraulic retention times (HRTs) of 12-48 hr, the dispersion numbers were found in the range of 0.017-0.32 and were not affected by HRTs variations. The short-circuit values were found to be in the range of 0.014-0.031 with the appearance of the tracer in the effluent within 5-30 min. The data of the laboratory- and actual-scale septic tanks reviewed unsatisfactory treatment performance, having effluent BOD₅ and fecal coliforms exceeding the discharge standards. A modified complete-mix model was developed based on the relationship between BOD₅ removal efficiency and HRTs which fitted well with the experimental and field-scale data. Methods to improve performance of septic tanks to minimize short-circuiting and increasing BOD₅ and pathogen reduction efficiencies were proposed.

Acknowledgments

The financial support received from the Bill & Melinda Gates foundation (BMGF) is gratefully appreciated. The authors wish to acknowledge the technical support provided by Dr.Variga Sawaittayotin and Dr.Suda Ittisupornrat of the Environmental Research and Training Centre (ERTC) in tracer analysis.

References

1. World Health Organization (WHO). Lacking sanitation [Internet], Carlton: World Health Organization; c2013 [cited 2013 July 24]. Available from: <http://www.who.int/ceh/risks/cehwater/en>.
2. Brandes M. Characteristics of effluents from separate septic tanks treating grey water and black water from the same house. USA: Toronto. Ontario; 1977.
3. Polprasert C. Septic tank and septic systems. Asian Institute of technology, Thailand: P.S. Service center; 1982.
4. Levenspiel O. Chemical reaction engineering. 3rd ed. New York: John Wiley and Sons; 1999.
5. Metcalf and Eddy. Wastewater engineering treatment and reuse. 4th ed. New York: McGraw-Hill; 2003.
6. Eaton AD, Clesceri LS, Rice EW, Greenberg AR. Standard methods for the examination of water and wastewater. 21th edition. Washington: American Public Health Association; 2005.
7. Edward L, Thackston F, Douglas S, Paul R. Residence time distributions of shallow basins. *Environ. Eng* 1987;113:1319-1332.
8. Pollution control department. Housing estate standards [Internet]. Carlton: Pollution Control Department; c2014 [cited 2014 March 3]. Available from: <http://www.pcd.go.th>.
9. Ittisupornrat S, Sienglum C, Wongsila K, Poonnotok A, Sunthornwatthanophon V, Yaithavorn P, Milintawisamai M. Environmental Research and Training Centre (ERTC). Project on efficiency verification testing of wastewater treatment tank. Carlton ERTC; c2014 [cited 2014 March 12]. Available from: <http://www.ertc.deqp.go.th/ertc/images/stories/user/water/water.pdf>.
10. Crites R, Tchobanoglous G. Small and decentralized wastewater management systems. San Francisco: WCB/McGraw Hill; 1998.
11. Wanasen S. Upgrading conventional septic tanks by integrating in-tank baffles [Thesis]. Bangkok: Asian Institute of Technology; 2003.
12. Nguyen AV, Pham NT, Nguyen TH, Morel A, Tonderski K. Improved septic tank with constructed wetland, a promising decentralized wastewater treatment alternative in Vietnam. International Conference of the National Onsite Wastewater Recycling Association (NOWRA) and International Water Association; 2007; IWA, Maryland, USA.