

Design of an extremely miniaturized planar ring hybrid

In Ho Kang[†] · Shu Zhong Sun¹

(Received July 2, 2013 ; Revised August 7, 2013 ; Accepted September 4, 2013)

Abstract: This paper presents a method for analyzing and designing an extremely miniaturized planar ring hybrid, using the combination of parallel and diagonally shorted coupled lines. In contrast to conventional miniaturized coupled line filters, it is proven that the required electrical length of transmission line can be largely reduced to even a few degrees, not only effectively suppressing the spurious passband but also approximately maintaining the same characteristic around the stable center frequency. A ring hybrid filter at center frequency of 1 GHz was fabricated on the FR4 epoxy glass cloth copper-clad plat (CCL) PCB substrate. The insertion loss of a ring hybrid filter with the die area of 30 mm × 30 mm is -4.68 dB. Simulated results are well agreed with the measurements.

Key words : stable center frequency, ring hybrid, coplanar coupled line, electrical length

1. Introduction

Ring hybrids are key components in many wireless and mobile communications as well as microwave, millimeter-wave circuits. The elementary line of the ring hybrid is a quarter transmission line that results in the large area and high cost for realizing in the circuit. To reduce the area of ring hybrid, several approaches were reported. One efficient method is to deploy the slotted ground which gives rise to slow wave effect in the printed circuit [1]. By connecting multiple open stubs on the inside of the ring, reduced ring hybrid is achieved [2]. Parallel coupled lines are applied to design a microstrip ring hybrids for size reduction [3]. However, these approaches for the miniaturization in the ring hybrid was limited in the size reduction. Therefore, major challenge for the miniaturization of ring hybrid is still remain.

In this paper, an extremely miniaturized ring hy-

brid filter using diagonally shorted coupled lines as well as parallel end-shortened coupled lines with lumped capacitors is introduced. As a new size-reduction method for $\lambda/4$ or $3\lambda/4$ transmission line, the size of the ring hybrid can be controlled arbitrarily in theory and reduced to just a few degrees without sacrificing the characteristics of the conventional ring hybrid filter at the operating frequency.

2. An extremely miniaturized ring hybrid

2.1 Conventional ring hybrid

A conventional ring hybrid has been shown in **Figure 1**, consisting of three quarter-wavelength transmission lines and one line with a length of $3\lambda/4$, at a center frequency. Generally, characteristic impedances of the ports and ring are 50Ω and 70.7Ω , respectively. Port1, 4 are usually used for the sum and difference ports.

[†] Corresponding Author: Department of Radio Engineering Korea Maritime and Ocean University 727 Taejongro, Youngdo-gu, Busan 606-791 Korea, E-mail: inkang@hhu.ac.kr, Tel: 051-410-4422

¹ Department of Radio Engineering Korea Maritime and Ocean University 727 Taejongro, Youngdo-gu, Busan 606-791 Korea, E-mail: 335830721@QQ.com, Tel: 051-410-4919

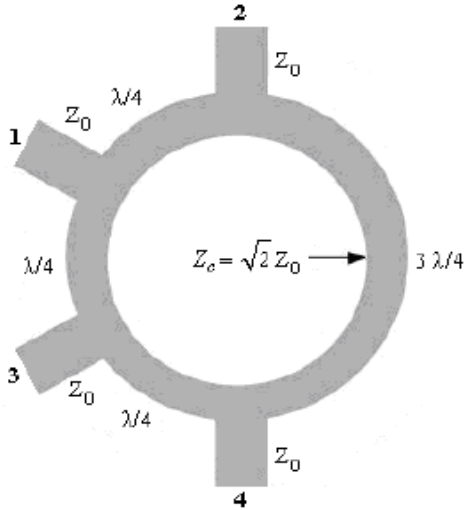

Figure 1: conventional ring hybrid circuit

2.2 Reduced size ring hybrid

In order to reduce the ring hybrid circuit, the quarter and $3\lambda/4$ section line composing it need to be miniaturized. The quarter transmission line shown in Figure 2(a) is shortened into the capacitive-loaded line Figure 2(b), by size reduction method proposed by Hirota [4]. The parallel end shorted coupled line in Figure 2(c) can be replaced by lumped inductive series element with shunt resonant circuits in the both side in Figure 2(d).

The related formulas are expressed by [5]

$$Z_1 = \frac{2Z_{Aoc}Z_{Aoo}}{Z_{Aoc} - Z_{Aoo}} = \frac{Z_c}{\tan\theta_1} \quad (1)$$

$$C_1 = C_{A0} + C_{A1} = \frac{1}{wZ_{Aoc}\tan\theta_1} + \frac{1}{wZ_c} \quad (2)$$

When $\omega L_{AL} = Z_c$ and $wC_{A1} = 1/Z_c$, it could be a quarter transmission line. The electrical length θ_1 need to decrease in Equation (1) for the miniaturization of quarter transmission line and the difference of Z_{Aoc} and Z_{Aoo} also decreases.

The diagonally end-shortened coupled line in Figure

2(e) is equal to the miniaturized capacitive load line with shunt resonant circuits in the both side in Figure 2(f) [6]. It can be relatively highly miniaturized comparing the capacitively loaded transmission line. This miniaturized coupled line is acted as $3\lambda/4$ transmission line because diagonally end-shortened coupled line section includes a phase inverter [7]. Since resonant circuit in the equivalent coupled line in Figure 2(f) is open at a center frequency, the miniaturized coupled line in Figure 2(e) is the same as capacitive loaded circuit with phase inverter Figure 2 (b).

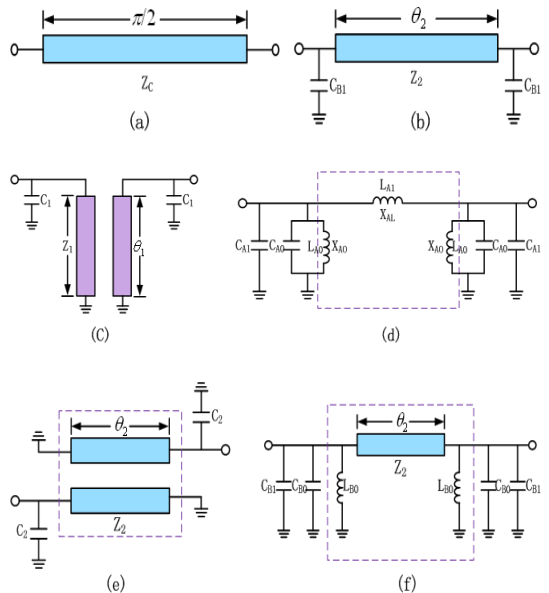

Figure 2: Quarter-wavelength transmission line(a), capacitively loaded transmission line(b), parallel end shorted coupled line(c), reduced capacitive load line with shunt resonant circuits(d), diagonally end-shortened coupled line(e) and miniaturized capacitive load line with shunt resonant circuits(f).

The related equations are expressed by as follows:

$$Z_2 = \frac{Z_c}{\sin\theta_2} = \frac{2Z_{Boc}Z_{Boo}}{Z_{Boc} - Z_{Boo}} \quad (3)$$

$$C_2 = C_{B0} + C_{B1} = \frac{1}{\omega Z_{Boe} \tan \theta_2} + \frac{\cos \theta_2}{\omega Z_c} \quad (4)$$

where Z_1, Z_2 and Z_c are the characteristic impedances of the shorted coupled lines and characteristic impedance of the quarter transmission line. θ_1, θ_2 and ω are the electrical lengths of the shorted line and angular frequency, respectively. C_{B1} is lumped capacitor in the capacitively loaded circuit, C_{A0} and C_{B0} are the capacitors for the resonance with shunt inductor. C_1 is the combination of C_{A0} and C_{A1} and C_2 is the combination of C_{B0} and C_{B1} . Z_{oe} and Z_{oo} are the even and odd mode characteristic impedance of coupled line.

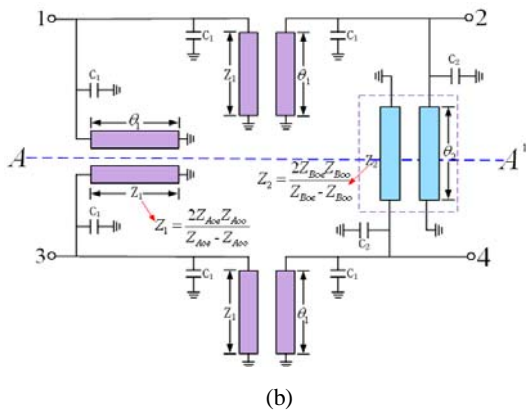
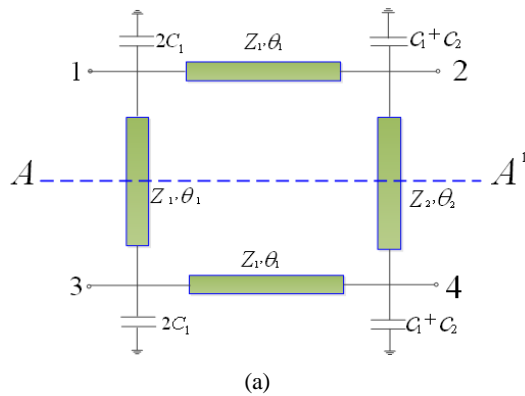

Figure 3: Reduced size ring hybrid circuit (a), equivalent circuit of ring hybrid with coupled line (b)

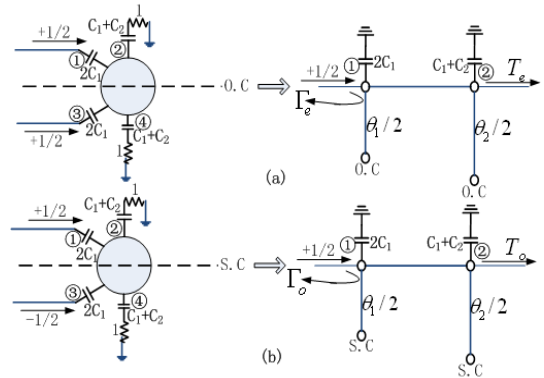

Figure 4: Even- and odd-mode decomposition of the ring hybrid when port 1 is excited with a unit amplitude incident wave. (a) Even mode. (b) Odd mode.

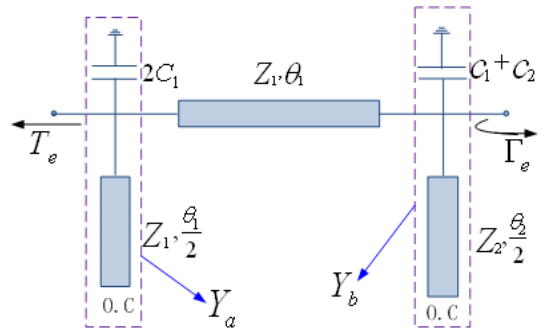

Figure 5: Even-mode excitation

$$Y_a = j\omega 2C_1 + j\frac{1}{Z_1} \tan \frac{\theta_1}{2}, Y_b \quad (5)$$

$$= j\omega (C_1 + C_2) + j\frac{1}{Z_2} \tan \frac{\theta_2}{2}$$

$$\begin{bmatrix} A_e & B_e \\ C_e & D_e \end{bmatrix} = \begin{bmatrix} 1 & 0 \\ Y_a & 1 \end{bmatrix} \begin{bmatrix} \cos \theta_1 & jZ_1 \sin \theta_1 \\ j\frac{1}{Z_1} \sin \theta_1 & \cos \theta_1 \end{bmatrix} \begin{bmatrix} 1 & 0 \\ Y_b & 1 \end{bmatrix} \quad (6)$$

$$= \begin{bmatrix} 1 & jZ_c \\ 2jY_c - 1 & \end{bmatrix}$$

Figure 3(a) is a miniaturized ring hybrid employing the capacitively loaded circuit. It can be transformed into equivalent circuit made up the reduced coupled lines shown in **Figure 3(b)** Actually this circuit with coupled lines will be fabricated for the ex-

tremely miniaturized ring hybrid circuit.

Analysis of the reduced size hybrid ring can be performed using the symmetry of the component with respect to a line $A-A^1$, as depicted in **Figure 3(a)** and the even-odd mode method. We can evaluate the required reflection and transmission coefficients defined using the ABCD matrix for the even- and odd-mode two-port circuits in **Figure 4**.

According to **Figure 4(a)**, if two signals of amplitude $1/2$ and in phase are applied at ports 1 and 3 (even-mode excitation), the magnetic wall is formed at $A-A^1$. This is equivalent to an open circuit, as indicated in **Figure 5**.

In a similar way, according to **Figure 4(b)** if two signals of amplitude $1/2$ and 180° out of phase (odd-mode excitation) are applied at ports 1 and 3, the electrical wall is created at $A-A^1$. This is equivalent to a short circuit, as indicated in **Figure 6**.

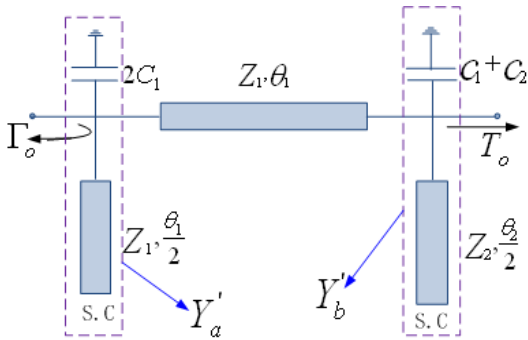

Figure6 Odd-mode excitation

$$Y'_a = jw2C_1 + j\frac{1}{Z_1} \cot \frac{\theta_1}{2}, Y'_b \quad (7)$$

$$= jw(C_1 + C_2) - j\frac{1}{Z_2} \cot \frac{\theta_2}{2}$$

$$\begin{bmatrix} A_o & B_o \\ C_o & D_o \end{bmatrix} = \begin{bmatrix} 1 & 0 \\ Y'_a & 1 \end{bmatrix} \begin{bmatrix} \cos \theta_1 & jZ_1 \sin \theta_1 \\ j\frac{1}{Z_1} \sin \theta_1 & \cos \theta_1 \end{bmatrix} \begin{bmatrix} 1 & 0 \\ Y'_b & 1 \end{bmatrix} \quad (8)$$

$$= \begin{bmatrix} -1 & jZ_c \\ 2jY_c & 1 \end{bmatrix}$$

The reflection and transmission coefficients for the even-and odd-mode of the ring hybrids are given by:

$$\Gamma_e = \frac{A_e + B_e - C_e - D_e}{A_e + B_e + C_e + D_e} \quad (9)$$

$$\Gamma_o = \frac{A_o + B_o - C_o - D_o}{A_o + B_o + C_o + D_o} \quad (10)$$

$$T_e = \frac{2}{A_e + B_e + C_e + D_e} \quad (11)$$

$$T_o = \frac{2}{A_o + B_o + C_o + D_o} \quad (12)$$

The amplitudes of the scattered waves from the ring hybrid will be:

$$B_1 = \frac{1}{2}(\Gamma_e + \Gamma_o) \quad (13)$$

$$B_2 = \frac{1}{2}(T_e + T_o) \quad (14)$$

$$B_3 = \frac{1}{2}(\Gamma_e - \Gamma_o) \quad (15)$$

$$B_4 = \frac{1}{2}(T_e - T_o) \quad (16)$$

Then with the aid of (9),(10),(11) and (12), according [8] we have:

$$B_1 = \frac{Z_c - 2Y_c}{Z_c + 2Y_c}, B_2 = \frac{2}{j(Z_c + 2Y_c)}, B_3 = \frac{2}{j(Z_c + 2Y_c)}, B_4 = 0$$

The input port 1 should be matched, so we let $B_1 = 0$, then we can get $Z_c = \sqrt{2}$, now the above results turn to be

$$B_1 = 0, B_2 = -\frac{j}{\sqrt{2}}, B_3 = -\frac{j}{\sqrt{2}}, B_4 = 0.$$

Which shows that the input port is matched, port 4 is isolated, and the input power is evenly divided and in phase between ports 2 and 3.

Now consider a unit amplitude wave incident at port 4 (the difference port) of the ring hybrid of

Figure 1. The two wave components on the ring will arrive in phase at ports 2 and 3, with a net phase difference of 180° between these ports. The two wave components will be 180° out of phase at port 1. This case can be decomposed into a superposition of the two simpler circuits and excitations shown in **Figure 7.**

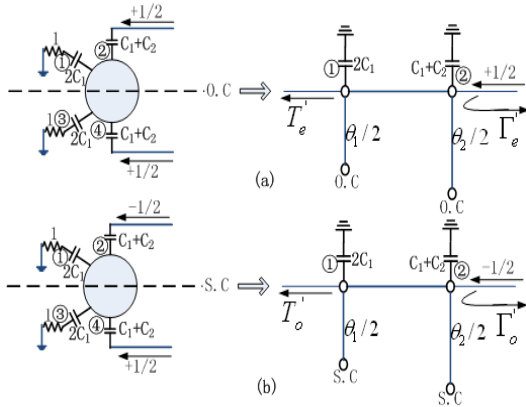

Figure 7: Even- and odd-mode decomposition of the ring hybrid when port 4 is excited with a unit amplitude incident wave. (a) Even mode. (b) Odd mode.

Similarly, the ABCD matrices for the even- and odd-mode circuits of **Figure 7** are

$$\begin{bmatrix} A'_e & B'_e \\ C'_e & D'_e \end{bmatrix} = \begin{bmatrix} -1 & jZ_c \\ 2jY_c & 1 \end{bmatrix} \quad (17)$$

$$\begin{bmatrix} A'_o & B'_o \\ C'_o & D'_o \end{bmatrix} = \begin{bmatrix} 1 & jZ_c \\ 2jY_c & -1 \end{bmatrix} \quad (18)$$

The amplitudes of the scattered waves from the ring hybrid will be:

$$B'_1 = \frac{1}{2}(T'_e - T'_o) \quad (19)$$

$$B'_2 = \frac{1}{2}(I'_e - I'_o) \quad (20)$$

$$B'_3 = \frac{1}{2}(T'_e + T'_o) \quad (21)$$

$$B'_4 = \frac{1}{2}(I'_e + I'_o) \quad (22)$$

Similarly, according to the above analysis, we can get

$$B'_1 = 0, B'_2 = -\frac{2}{j(Z_c + 2Y_c)},$$

$$B'_3 = \frac{2}{j(Z_c + 2Y_c)}, B'_4 = \frac{Z_c - 2Y_c}{Z_c + 2Y_c}.$$

The input port 4 should be matched, so we let $B'_4 = 0$, then we can get $Z_c = \sqrt{2}$, now the above results turn to be

$$B'_1 = 0, B'_2 = \frac{j}{\sqrt{2}}, B'_3 = -\frac{j}{\sqrt{2}}, B'_4 = 0.$$

Which shows that the input port is matched, port 1 is isolated, and the input power is evenly divided into ports 2 and 3 with a 180° phase difference.

3. Simulations and measurements

3.1 Simulation Results

Once the ring hybrid filter equivalent circuit model was built, physical filter structures such as resonators and coupled-line sections can be designed. However, one thing needs to be kept in mind that due to the parasitic components (both internally and externally) the synthesized filter model cannot be transformed into physical structures at one shot. As a result, some circuit tuning for the filter responses and optimizations of the filter physical dimensions need to be carried out. Generally, it is carried out with Ansoft HFSS before fabrication until the full-wave electromagnetic (EM) simulation shows a good performance close to the target one.

We designed the miniaturized ring hybrid circuit employing the coupled lines of 15 degrees for replacing quarter transmission line. **Table 1** gives the design parameters of the HFSS simulation. **Figure 8** (a) and (b) show simulated the insertion and return loss

Table 1: Design parameters of the HFSS simulation

Center frequency	1GHz
Substrate thickness	0.8 mm
Substrate permittivity	4.4
Dielectric loss tangent	0.02
Copper thickness	35 μ m
Copper conductivity	6.17 \times 107
Width of coupled lines	0.67 mm
Length of coupled lines	8.245 mm
Slot of coupled lines	0.55 mm
Capacitor	4.1 pF
Ports impedance	50 Ohm
Circuit size	30 mm \times 30 mm

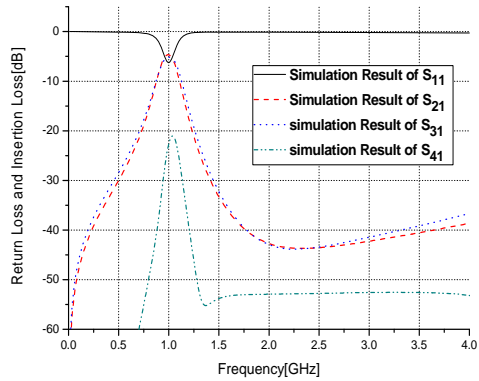

(a)

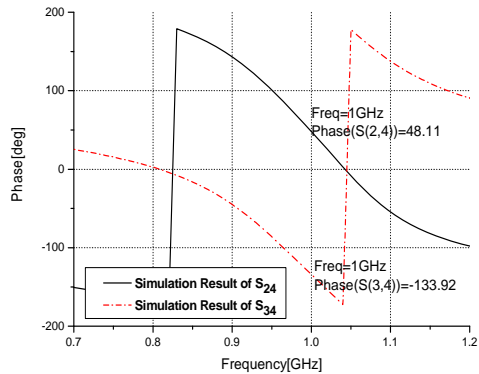

(b)

Figure 8: The simulation results of ring hybrid filter frequency response (a) and phase response (b)

responses of the ring hybrid filters, respectively. The parameter values in the **Table 1** were appropriately tuned for proper simulation results.



Figure 9: A photograph of the fabricated ring hybrid.

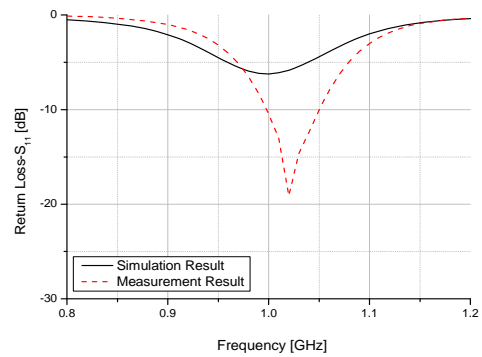

(a)

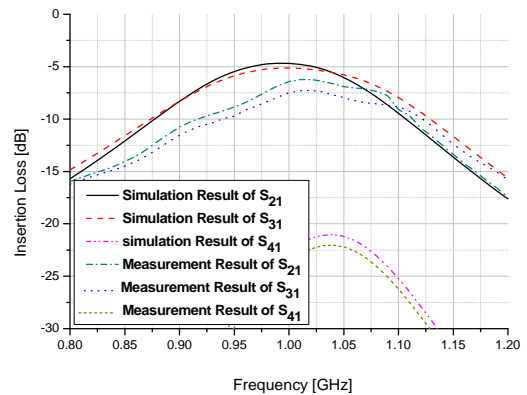

(b)

Figure 10: Measured frequency performances compared with HFSS simulation results of input return loss S_{11} (a), insertion loss S_{21} , S_{31} and S_{41} (b)

3.2 Measurement Results

The photograph in **Figure 9** shows a fabricated ring hybrid with 4 ports, with total die area (including the

capsulated ground plane) of 30 mm × 30 mm. It was manufactured on the FR4 epoxy glass cloth copper-clad plat (CCL) PCB substrate having thickness 0.8mm and dielectric constant $\epsilon_r=4.4$. The measured performances of the fabricated at 1GHz ring hybrid is compared with HFSS simulation results in **Figure 10** and **Figure 11**. It shows equal power splitting performance and good phase response. The insertion loss of simulation results by HFSS is -4.68dB and measurement result is -6.42dB. Additional loss in the measurement is considered to be caused by surface and edge roughness of the metal, inferior metal conductivity, the dielectric loss of the substrate and the inexactness of fabrication technology and so on, which were not taken into account in the calculations. The ring hybrid operating at 1 GHz exhibits a bandwidth of 130MHz and $180^\circ \pm 6^\circ$ degree phase difference.

Finally, **Table 2** summarizes the characteristic of several published ring hybrid in comparison with this work. Obviously, the proposed in this paper shows the advantage of more compact size, excellent insertion loss characteristic.

Table 2: Comparison of different types of Ring Hybrid

Reference	This work	[2]	[3]	[9]
Technology	PCB	PCB	PCB	LTC C
Center Frequency(GHz)	1	1	2.45	2.4
Electrical Length	$\lambda g/4$	$\lambda g/24$	$\lambda g/8$	$\lambda g/4$
	$3\lambda g/4$	$\lambda g/24$	$\lambda g/8$	$\lambda g/4$
Bandwidth	$0.13f_0$	$0.55f_0$	$0.33f_0$	$0.653f_0$
Insertion Loss(dB)	-6.42	-4.03	-3.52	-3.56
Die Area(mm ²)	30×30	22×30	27×30	2.71×2.33
Year	2013	2005	2007	2009

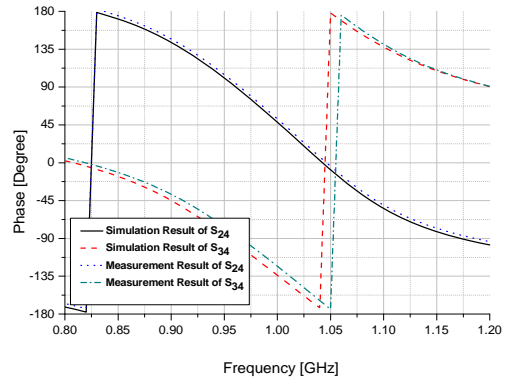

Figure 11: Measured phase response compared with HFSS simulation result

4. Conclusion

Miniaturization method of ring hybrid filter using coupled line circuits has been proposed in the planar structure. The electrical length of the coupled lines in the ring hybrid could be reduced up to a few degrees and the size of ring hybrid shrunk about 35 times smaller than conventional one. The measurement responses agree well with simulation result curves. Ring hybrid can be easily fabricated that it makes this design suitable for microwave integrated circuit(MIC) and MMIC applications.

References

- [1] Y. J. A Sung, C. S. Ahn, and Y.-S. Kim, "Size reduction and harmonic suppression of rat-race hybrid coupler using defected ground structure," IEEE Microwave Wireless Components Letters, vol. 14, no. 1, pp. 7-9, 2004.
- [2] M. L. Chuang, "Miniaturized ring coupler of arbitrary reduced size," IEEE Microwave Wireless Components Letters, vol. 15, no. 1, pp. 16-18, 2005.
- [3] H. S. Lee and K. Choi, "A harmonic and size reduced ring hybrid using coupled lines," IEEE Microwave Wireless Components Letters, vol. 15, no. 1, pp. 16-18, 2005.

- [4] T. Hirota, "Reduced-size branch-line and rat-race hybrids for uniplanar MMIC's," IEEE Transactions, Microwave Theory Techniques, vol. 38, no. 3, 1990.
- [5] I. Kang and J. S. Park, "A reduced-size power divider using the coupled line equivalent to a lumped inductor," Microwave Journal, vol. 46, no. 7, 2003.
- [6] I. Kang, S. Shan, X. Wang, Y. Yun, J. Kim, and C. Park, "A Miniaturized GaAs MMIC filter for the 5GHz band," Journal of Microwave, vol. 50, no. 11, pp. 88-94, 2007.
- [7] S. P. Marsh, "A wide-band stripline hybrid ring," IEEE Transactions, Microwave Theory Techniques, vol. 16, no. 6, p. 361, 1968.
- [8] D. M. POZRA, Microwave Engineering, Wiley, New York, 1998.
- [9] Tze-Min Shen, Chin-Ren Chen, Ting-Yi Huang, and Ruey-Beei Wu, "Design of lumped rat-race coupler in multilayer LTCC," Asia Pacific Microwave Conference, pp. 2120-2123, 2009.