

## A study on the use of pure palm oil (biodiesel-DO) as an alternative fuel on the fuel supply system of marine diesel engines

DANG VAN UY<sup>†</sup>

(Received November 6, 2013 ; Revised November 11, 2013 ; Accepted November 20, 2013)

**Abstract:** The biodiesel used as an alternative fuel for diesel engines is well-known, however the price of the bio-diesel is still higher than conventional diesel oil (DO) by 10% to 15% depending on a kind of bio-oil and a country producing the bio-diesel. One of idea to reduce the price of bio-diesel is to use the pure bio-oil as fuel for marine diesel engines, because to use the pure bio-oil as fuel without the esterification process can reduce the price of bio-fuel.

At present time, some experts in some countries who have been carrying out experiments on the use of pure bio-oil produced from rape seeds, sunflower seeds... as fuel for marine diesel engines have achieved important results. In recent years, at Vietnam Maritime University we also have been using the pure palm oil and its blended fuel (Palm oil and DO) as fuel for marine diesel engines in laboratory and on board of ships. The blended fuel is a mixing fuel of the pure palm oil and diesel oil with content of pure palm oil by 5%, 10%, 15%, 20% and 35%. In this paper, we would like to present some results from our experiments to investigate the impacts of using the palm oil and its blended fuel on the important technical features of the fuel supply system of marine diesel engines such as the fuel supply amount for one cycle, fuel supplying pressure, ignition delay time and so on. The results from the research will be good fundamental parameters to support proper operation of marine diesel engines using bio-oil and blended fuels as alternative fuel in near future.

**Keywords:** Pure palm oil, blended fuel, alternative fuel, diesel engine, Vietnam Maritime University.

### 1. Background

The fuel crisis and environment protection are forcing all the countries in the world to seek for new alternatives to substitute the fossil fuel. At present time, the scientists have already studied and proposed a lot of researches, but almost of them are based on renewable fuels including bio-fuel. To use bio-fuel on commerce purpose, there are some leading countries, such as USA, Brazil, Argentina, Germany, The Netherland, Indian, China and some ASIAN countries. However, bio-fuel application, especially bio-diesel

for current operating marine diesel engines, must be checked carefully, because of differences of bio-diesel on physics and chemistry characteristics from the traditional fuel oil. In case of lack of careful check and suitable engine modification, it can result in bad trouble. Some impacts of biodiesel and blended biodiesel fuel to engine's operation can be listed as: output, efficiency, fuel consumption, poison gas components in exhaust gas, corrosion and wear out the engine part. However, in this study, the author focuses on

---

<sup>†</sup> Corresponding author: Vietnam Maritime University, E-mail: [dvuy@hn.vnn.vn](mailto:dvuy@hn.vnn.vn)

impacts of using the pure palm oil (PPO) and mixed fuel (PPO-DO) as an alternative fuel on the fuel supply system of marine diesel engines. Because the rule and feature of supplied fuel are main factors influencing on working process of diesel engines in general and marine diesel engine in particular.

## 2. The roles of fuel oil system on working process of marine diesel engine

### 2.1 Functions and requirements of fuel oil system

The function of fuel oil system is to supply fuel oil to the combustion chamber in the form of fine mist on timing of diesel engine working process. To ensure the diesel engine working with high efficiency, the fuel oil system must be met the following requirements:

- \* Timing: The fuel must be injected in time as engine requirement;
- \* Metering: A mount of supplied fuel must be enough in connection with an engine operating regime and amount of fuel supplied for each cylinder must be equal...;
- \* Constant pressure: To ensure that the required injection pressure and diesel engine can work properly at minimum optimization revolution (app.20 ÷ 30% rated revolution);
- \* Atomization: Fuel oil must be injected in the form of fine mist;
- \* Fuel distribution: Fuel must be sprayed in all combustion chamber volume for steady mixing with the inlet air. Thus makes the fuel be burning quickly and clean.

### 2.2 Structure and components of fuel oil system for marine diesel engine

#### 2.2.1. Structure of fuel oil system

Marine diesel engine is equipped to drive propeller as the main propulsion or generator as auxiliary

machinery. Diesel engine is using Diesel Oil (DO) or Heavy Fuel Oil (HFO) with poorer quality for working. With different kinds of fuel oil, the fuel oil system also needs the different structure requirements. Thus, the marine fuel oil system can be classified into two types:

- Diesel Oil System (DO System);
- Heavy fuel oil system (HFO System).

In general, DO system installed in small type, high speed marine diesel engine and FO system installed in large power, low speed ones operated with both of HFO and DO. Thus, DO system and HFO system always have some basic differences, in **Figure 1**, we can see one of typical HFO system:

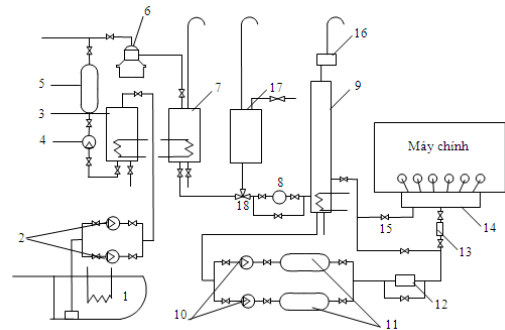

**Figure 1:** HFO system. 1. Store tank (HFO); 2. Transfer pump; 3. HFO settling tank; 4. Supply pump for purifier; 5. Heater; 6. Purifier; 7. HFO service tank; 8. Flow meter; 9. Mixing tank; 10. Circulating pump; 11. Heater; 12. Viscometer; 13. Filter; 14. Fuel injection pump; 15. Return lines; 16. Air vent; 17. D.O tank; 18. Three way valve.

In comparison between HFO system and DO system, we can see the following basic differences:

- There is no Mixing tank (9) in DO system, because the diesel engine is only operating with diesel oil when ship sailing or maneuvering. On the contrary,

A study on the use of pure palm oil (biodiesel-DO) as an alternative fuel on the fuel supply system of marine diesel engines

in HFO system, there must be used DO when maneuvering, and thus, mixing tank is very important for transferring HFO to DO and vice versa;

- In many case, in DO system, fuel oil heater is not required.

### 2.2.2. The basic components of fuel oil system

In fact, to make sure the diesel engine can work safely and efficiently, the fuel oil system must be equipped the following component:

#### 1. Tanks

When a ship sailing, necessitates the inclusion of the follows tanks in the fuel system:

Storage tank: To store fuel oil for ship;

Settling tank: Here the HFO is settled for few days so that water, sludge and other impurities can be separated and drained out...according to gravity separation;

Service tank: Purified oil is stored in service tanks for immediate use;

Mixing tank: Its purpose is to produce a gradual variation of fuel quality during transition period from diesel oil to heavy fuel oil or vice versa

#### 2. Filter

There are two kinds of filter: fine filter and pre-filter. In some kinds of diesel engines, filter installed above fuel injector.

- Pre-filter is installed before the supply pump. Its core is made by net with 0,1 mm eye bore.

- Core of fine filter is made by laminated soft paper. Some types of cloth or felt, some types of fiber around perforated pipe. Fine filter installed after supply pump.

#### 3. Supply pump

Its function is to transfer the fuel oil from service tank to fuel injection pump. Another name for this pump is charged pressure pump or circulating pump. In fact, this pump is driven by diesel engine or in-

dividual electric motor.

#### 4. Fuel injection pump

Fuel injection pump is the main part of fuel oil system. There are two kinds of fuel injection pump: Bosch type and valve-controlled type. In-line pumps are used in the small-engine-size range, individual single barrel injection pumps are used in larger diesels. Fuel injection pump is connected with fuel injector by high pressure tube.

#### 5. Fuel injector

Its function is to supply fuel oil into combustion chamber in timing and metering. Fuel oil is sprayed in the cylinder in the form of fine mist.

#### 6. Piping

High pressure pipe is used for transferring fuel oil from injection pump to injector. Low pressure one is for transferring from service tank to fuel injection pump by transfer pump. Furthermore, low pressure one leads the returned oil from fuel injection pump and fuel injector to tank.

Among those devices, the fuel injection pump and fuel injector play an important role for warranting sprayed fuel oil on timing, metering and fine mist. Figure 2 shows the Bosch piston types of fuel injection pump with different adjustment methods of supplied fuel amount.

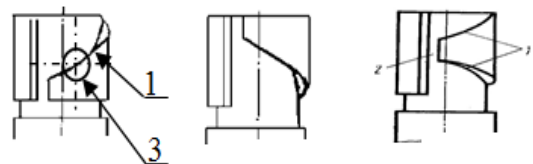

(a) (b) (c)  
**Figure 2:** Adjustment methods on supplied fuel oil amount. a: Initial adjusting, b: Terminal adjusting, c: Combined time adjusting, 1: Helical groove, 2: Vertical groove, 3: Discharge hold

In **Figure 3**, it shows character of pump adjustable at the beginning of the delivery stroke. Hence, helical groove on the piston (1) will covering capacity Vertical groove (2) on the plunger when they move from bottom to top. (**Figure 2-a**).

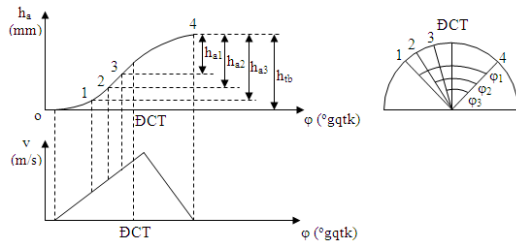

**Figure 3:** Initial adjusting amount of fuel oil supply (pump adjusted by beginning of fuel delivery)

To adjust amount of fuel oil supply for the working process of diesel engine, we change relative and position between plunger and barrel. Thus, when piston move up, at (1) the piston stroke is maximum, and then, amount of fuel delivery is maximum, at (2), (3), the piston stroke is smaller, it resulting in a less amount of fuel oil supplied. (**Figure 3**).

### 2.3 Impacts of fuel oil system on working process of diesel engine

In marine diesel engine, fuel oil system plays very important role for adjusting initiation and controlling ignition process in the combustion chamber. If fuel injected into combustion chamber in good form of fine mist, on timing, the diesel engine shall work with higher efficiency, power, and vice versa. Thus, engine-working process will be depended into the following factors:

- Supplying pressure of fuel injection pump;
- Injecting pressure of fuel injector;
- Timing of fuel oil supplied;
- Amount of fuel oil supplied for process.

Besides these, there are some others effecting fac-

tors such as: fuel oil temperature, fuel oil viscosity...

In each diesel engine, the fuel oil system must be designed suitably with kinds of using fuels (DO or HFO), in case using other kind of fuel oil, the specific parameters of fuel oil system will be effected and resulting in decrease of working efficiency, power.. of an engine. Therefore, the problems as: using the bio-diesel or pure palm oil (biodiesel-DO) as an alternative fuel on the fuel supply system of marine diesel engines, what is effected? This is main point of our study research.

## 3. Impacts on the working parameters of fuel oil system

### 3.1 Experimental engine

- Engine name: HANSHIN Diesel engine 6UL32
- Number of cylinder: 6
- Cylinder bore (diameter): 320 mm
- Piston stroke: 540 mm
- Maximum power: 1300ml/970kW at revolution of 340 rpm
- Fuel consumption: 200g/kW.h
- Max. Pressure: 90kG/cm<sup>2</sup>
- Delay closing angle of suction valve: 11o
- This engine as main engine and driven propeller on board ship
- Experimental fuel oil is Pure Palm Oil and mixed fuel, with the follows characters:

The main reason for choosing Pure Palm Oil:

- There are many researches about Bio-Diesel and Blended biodiesel fuel in the world, and to have bio-diesel, it is required complicate esterifies process to product bio-diesel;
- We can easily to product Pure Palm Oil by available materials.

### 3.2 Elementary theory

**Table 1:** Property of Pure Palm Oil and Mixed fuel

| No. | Features                | DO     | B100   | Blended biodiesel fuel |        |        |        |
|-----|-------------------------|--------|--------|------------------------|--------|--------|--------|
|     |                         |        |        | B5                     | B10    | B15    | B20    |
| 1   | Density at 15oC,kg/m3   | 0,8464 | 0,9225 | 0,8489                 | 0,8538 | 0,8568 | 0,8599 |
| 2   | Viscosity at 40oC,mm2/s | 6,38   | 85,80  | 7,0                    | 7,42   | 8,20   | 9,31   |
| 3   | Cetane number           | 52,92  | 42,89  | 52,11                  | 51,25  | 50,91  | 50,66  |
| 4   | Heating value, kcal/kg  | 10.750 | 10.325 | 10.700                 | 10.625 | 10.600 | 10.580 |
| 5   | Flash point oC          | 72     | 224    | 72                     | 73     | 74     | 75     |
| 6   | Pour point oC           | -6     | 16     | -3                     | -1     | 0      | 1      |
| 7   | Water content mg/kg     | 170    | 315    | 182                    | 189    | 195    | 201    |

### 3.2.1 Estimating impacts of fuel oil on injection pressure

Volume flow rate by pump is equivalent with volume of fuel injected into combustion chamber [2][3]:

$$Q_b = Q_{vp} \quad (1)$$

Therefore, injecting pressure can be calculated:

$$p_{ph,lt} = p_c + \frac{p_{nl}\pi^2}{1800} \left( \frac{F_b}{\phi_{cn}F_i} \right)^2 \left( \frac{dh_a}{d\phi} \right)^2 n^2 \quad [\text{Pa}] \quad (2)$$

In which:

$\phi_{cn}$ :flow coefficient;  $p_c$ : fractions pressure at the moment of fuel injected into the cylinder [Pa];  $\rho_{nl}$ : Fuel density at injection time [kg/m<sup>3</sup>];  $F_i$ : injector nozzle bore area [m<sup>2</sup>];  $i$ : number of nozzle orifices;  $h_a$ :Piston stroke of fuel injection pump [m];  $\phi$ : angle of crankshaft rotation [rad];  $F_p$ :Cross area sectional of fuel injection pump [m<sup>2</sup>];  $n$ :revolution of engine [v/p].

Based on formula (2), it shows that:

- Fuel injected pressure is first - order function proportion with density at constant revolution of the engine;

- Fuel injected pressure is square-law proportion with revolution of the engine.

### 3.2.2 Estimating impacts of fuel oil on injection flow

Injection process is the mobility of liquid through the fuel injector. If hydraulic loss in fuel injector, leakage loose are neglected, according to principle of Bernoulli [2]-[4]:

$$\frac{W_{ph,lt}^2}{2} + \frac{p_{ph,lt}}{\rho_{nl}} = C \quad (3)$$

From formula (3), injection flow:

$$Q = iF_i \sqrt{2 \left( C - \frac{p_{ph,lt}}{\rho_{nl}} \right)} \quad [\text{kg/h}] \quad (4)$$

In which: C- constant; i - number of nozzle orifices;  $\rho_{nl}$ :specific gravity of fuel oil [kg/m<sup>3</sup>];  $p_{ph,lt}$ : fuel injected pressure [Pa];  $W_{ph,lt}$ : Fuel flow rate through nozzle[m/s].

Or another formula:

$$Q = C_D F_i \sqrt{2\rho_{nl}\Delta P} \quad (5)$$

In Which:  $F_i$  - nozzle area [m<sup>2</sup>];  $C_D$  - injected coefficient;  $\rho_{nl}$ -density of fuel oil [kg/m<sup>3</sup>];  $\Delta p$ -pressure drop when fuel injected. If  $\Delta p$ ,  $F_i$  are the constant, amount of injected fuel:

$$Q = C_D F_i \sqrt{2\rho_{nl}\Delta P} \frac{\Delta\theta}{360n} \quad (6)$$

In which:  $\Delta\theta$ -period of fuel injected [oCA], n-revolution [rpm].

### 3.2.3 Impacts of fuel oil to the moment of fuel injection and ignition delay of fuel oil

Moment of fuel injection is the moment when the nozzle is opened by pressure of fuel injection pump.

Theoretically, the time when the fuel injection pump starts to work and moment of fuel injected is the same, there is no delay time. However, because of expanding of high pressure tube, leakage of piston-plunger of fuel injection pump, and, leakage of nozzle, thus, there is delay time between starting time of fuel injection pump and moment of fuel injected. Therefore, when we use different kinds of fuel oil for diesel engine, a moment of fuel injection depends on pressure and viscosity of fuel oil. In case of replacement traditional diesel oil by bio-diesel oil but keeping viscosity, the moment of fuel injection with bio-fuel only depends on their density. However, this difference is neglected for working process of diesel engine.

Since the ignition characteristics of the fuel effect the ignition delay, this property of fuel is very important in determining diesel engine operating characteristics, Blended biodiesel fuel with difference ratio: B5, B10, B15, B20 have smaller Cetane number in comparison with DO, in which, the ignition quality of a fuel is defined by its Cetane number. According to experimental, the ignition delay [2]:

$$\tau_i = Ap^{-n} \exp\left(\frac{E_A}{RT}\right) \quad (7)$$

In Which:  $\tau_i$  - ignition delay [ms];  $E_A$  - an apparent activation energy for the fuel autoignition process [J/mol]; R - universal gas constant [8,3143 J/mol.°K]; p-pressure at the end of compression stroke [bar]; T-temperature at the end of compression stroke [°K]; A,n-constants depends on fuel oil.

Formula (7) was built basing on experimental of closing space without parameters: mixed burning air in the combustion chamber. This formula is used for all kinds of fuel oil, thus, low accuracy. To make higher accuracy, we can calculate by Arrhenius adjustment formula:

$$\tau_i = Ap^{-n} \exp\left(\frac{E_A}{RT}\right) \phi^{-k} \quad (8)$$

In which:  $k$ - experimental coefficient;  $\phi$ - ratio of fuel oil - charging air: 0,116.

Based on formula (7) and (8), The Ghent University, Belgium was found the formula:

$$\text{For Pure Palm Oil: } \tau_i = \frac{\exp\left(\frac{1130}{T}\right)}{p^{0.34} \rho^{0.02}} \quad (9)$$

$$\text{For rapeseed oil: } \tau_i = \frac{\exp\left(\frac{1145}{T}\right)}{p^{0.34} \rho^{0.06}} \quad (10)$$

### 3.3 The experimental data

#### 3.3.1. Determine the impacts of the kind of fuel on injected pressure

The research team also carried out test in the impacts of mixed fuel (biodiesel oil - DO) on injected pressure. The testing method of research is showed in **Figure 4** as follows:

- Test fuel injector on DO at ambient temperature and injection pressure of 280 kG/cm<sup>2</sup> (It is the standard pressure which is stipulated by maker) and measuring on the diameter of fuel spray which is recorded on A4 paper placed in 40mm far from fuel injector.

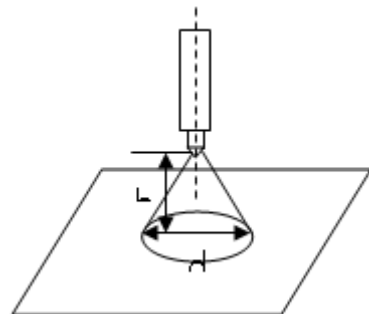

**Figure 4:** Measuring and evaluation on injected pressure of fuel oil

- Test in turn on the different mixed fuel B5, B10,

A study on the use of pure palm oil (biodiesel-DO) as an alternative fuel on the fuel supply system of marine diesel engines

B15 and B20 at the injected pressure 280kG/cm<sup>2</sup> and similar viscosity;

- The research team carried out take diameter of DO spray as a standard; Adjust tension of fuel injector spring so that diameter of the other fuel sprayed is similar to the diameter of DO sprayed; Test injected pressure on meter and record the results in **Figure 2**.

**Table 2:** Diameter of fuel sprayed

| Diameter of fuel sprayed                               | Kinds of fuel |       |       |       |       |
|--|---------------|-------|-------|-------|-------|
|  | DO            | B5    | B10   | B15   | B20   |
| d,[mm]   | 32,20         | 32,24 | 32,25 | 32,27 | 32,28 |
| Differences of injected pressure of fuel [ $kG/cm^2$ ] | 0             | - 3,5 | - 4,4 | - 6,3 | - 7,8 |

The data on the **Table 2** shows that: Regarding to the other fuels, diameter of fuel sprayed is also different as its increasing from 32.20 mm (DO) to 32.28 mm (B20). This shows that the injected fuel spray of the high density fuel (B20: 0,8668  $kg/dm^3$ ) is farer than the injected fuel spray of the low density fuel at the constant injected pressure.

The research team measure the injected pressure of fuel oil for the engine 6LU32 by the high accuracy pressure sensors and the results are shown in the **Figure 5**.

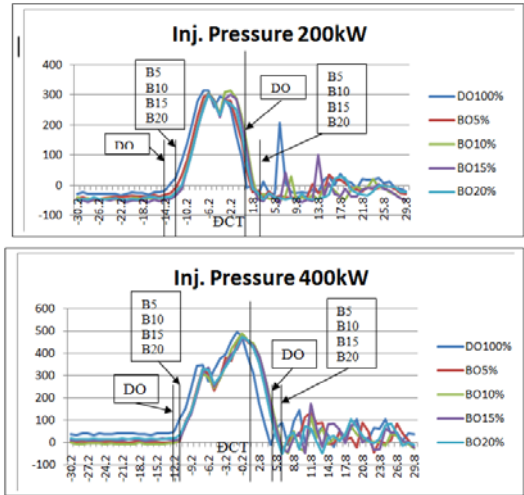

**Figure 5:** injected pressure for the different fuels

On the basis of data on the fuel injected pressure as shown in **Figure 5**, we were able to separate data on the highest stuffing pressure for all kind of fuel and injection time of fuel as in **Table 3**.

3.3.2. The impact of the kind of fuel on injection capacity

**Table 4** shows the supplied fuels vary on the other fuels at the similar rotation mode which is calculated for engine 6UL32, maker is Hanshin (JAPAN).

**Table 4** is the result of the theoretical calculation of fuel amount injected into the engine when changing the kind of fuel.

In this case, the research team applied the formula (2) to calculate on engine 6LU32 of Hanshin manu-

**Table 3:** Highest fuel injected pressure and injection timing

| Loading system [kW] | Injected pressure of fuel [ $kG/cm^2$ ] |        |       |        |     |        |     |        |     |        |
|---------------------|---|--------|-------|--------|-----|--------|-----|--------|-----|--------|
|                     | Kind of fuel & Time of highest pressure |        |       |        |     |        |     |        |     |        |
|                     | DO                                      |        | B5    |        | B10 |        | B15 |        | B20 |        |
|                     | P                                       | Timing | P     | Timing | P   | Timing | P   | Timing | P   | Timing |
| 200                 | 314                                     | -7,2   | 302,3 | -6,2   | 314 | -2,2   | 303 | -6,2   | 300 | -6,2   |
| 400                 | 495                                     | -1,2   | 484   | -0,2   | 486 | -0,2   | 465 | -0,2   | 472 | -0,2   |

**Table 4:** Impact of kinds of fuel on supplied amount in theory

| Revolution<br>(v/p) | The amount of fuel supplied to the engine |       |       |       |       |       | Remark  |
|---------------------|---|-------|-------|-------|-------|-------|---------|
|                     | DO  | B5    | B10   | B15   | B20   | B100  |         |
| 340                 | 3,17                                      | 3,18  | 3,19  | 3,20  | 3,21  | 3,33  | g/s     |
| 340                 | 1,132                                     | 1,135 | 1,139 | 1,142 | 1,146 | 1,189 | g/cycle |

facturer at nominal power. The amount of injected fuel calculated according to time [g/s] and according to cycle [g/cl]. The calculation results show that: depending on the density of the fuel, the amount of fuel injected into the engine will be changed

**Table 5:** Impact of kind of fuel on supplied amount in experiment

| The amount of injection fuel/time (cycle), g | Kind of fuel |         |        |         |         |
|--|--------------|---------|--------|---------|---------|
|  | DO           | B5      | B10    | B15     | B20     |
| Q (g)  | 1,132        | 1,172   | 1,224  | 1,266   | 1,302   |
| Change (%)                                   | 0            | + 3,533 | + 8,12 | + 11,83 | + 15,01 |

**Table 5** shows the measurement data of the injection fuel of nozzle in experiment. The research team used fuel injection pump testing equipment at laboratory of Faculty of Marine Engineering - Vietnam Maritime University for evaluating the injection fuel over each fuel according to the process.

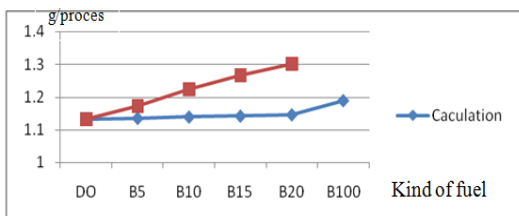

**Figure 6:** Impact of kind of fuel on amount of fuel injected

Comparison between the cycle fuel in theoretical calculation and that in experimental calculation is shown in Figure 6. According to theoretical calculation, the difference of the amount of fuel injected into the engine is not much on different fuels (from DO to B20). On the contrast, the difference becomes greater and reaches +15.01% (B20/DO) in experimental measurement.

3.3.3. Impacts of kind of fuel on injection timing and ignition delay

The ignition delay of fuel is defined by its Cetane number and working conditions of the engine, such as: load regime, speed, temperature at the end of the compression process... The research team used the different fuels for diesel engine and used the modern equipment for analyzing combustion process of AVL manufacturer (Republic of Austria) for providing and collecting data on delay combustion of different fuels as shown in **Figure 7** and **Table 6**.

The data in **Table 6** is made when the diesel engine is running at load regime of 400 kW and rotation 238

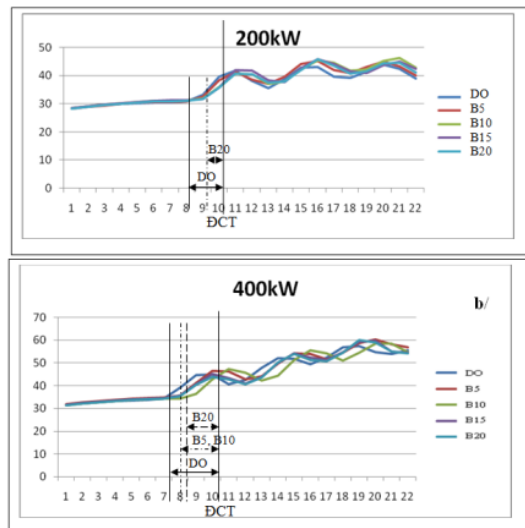

**Figure 7:** The ignition delay of Blended bio-diesel fuels



**Table 6:** The ignition delay of the different fuels

| No. | Kind of fuel | CETANE number | Ignition point before TDC [°crank angle] |
|-----|--------------|---------------|--|
| 1   | DO           | 52,92         | 2,1010                                   |
| 2   | B5           | 52,11         | 1,8447                                   |
| 3   | B10          | 51,25         | 1,2140                                   |
| 4   | B15          | 50,91         | 0,9700                                   |
| 5   | B20          | 50,66         | -0,6733                                  |

rpm, using alternative fuels from DO to B20. At the last column of Table 6, the value is measured in rotation angle of crankshaft [°crank angle], here it should be understood as the period from the beginning of combustion of fuel to top dead center (TDC) of DO fuel 2,101 [°crank angle], TDC of B5 is 1.8447, while TDC of B20 is -0.6733.

In case of Blended bio-diesel fuel B20, the begin ignition after top dead center of the engine which is 0.6733 [°crank angle].

Thus, the fuel have Cetane value number much smaller than Cetane value of DO, then the ignition delay is greater, it is entirely comply with the actual rules.

### Conclusions

On the basic data obtained from theoretical and experimental research, we can conclude using of pure palm oil and its blended fuel directly affected on the operation parameters of the fuel oil system of marine diesel engines as follows:

The blended bio-diesel fuel (Pure palm oil - DO) tend to increase fuel supply pressure into engine, because the blended bio-fuel fuel have greater density than DO;

The blended bio-fuel fuel (Pure palm oil - DO) tend to increase an amounts of fuel supplied of a cycle into engine combustion chamber;

The blended bio-diesel fuel (Pure palm oil - DO) tend to increase ignition delay of the blended fuel.

Therefore, in order to use blended bio-diesel fuel as

alternative fuel for diesel engines in general and for marine diesel engines in particular safely and effectively, it is necessary to adjust fuel oil system such as: injection time, injection pressure of fuel injector and the area of nozzle orifices. The adjustment data should be identified correctly based on the specific experiments of each kind of blended bio-diesel fuel.

### References

- [1] Kees Kuiken, "Diesel engines for ship propulsion and power plants", Onnen, The Netherland, July 2008.
- [2] John B. Heywood, International Combustion Engine Fundamentals, McGraw-Hill Book Company, 1988.
- [3] Bernard Challen and Rodica Baranescu, Diesel Engine Reference Book, Butterworth-Heinemann, Oxford OX2 8DP, 1999.
- [4] Ildefons Piotrowski, Kazimierz Witkowski, and Okretowe Silniki Spalinowe, Trademar, Gdynia-Poland, 2003.
- [5] Hachiro KIDO, The Basis of Diesel Plant Performance Calculation, H.KIDO (PhD), 2010.
- [6] Marcus Boyd, "The auto-ignition properties of Biodiesel Fuels", The University of ADELLAIDE, Australia October 2007.
- [7] B. Terry, "Impact of biodiesel on fuel system component durability", The Associated Octel Company Limited, September 2005.
- [8] Establishment of the Guidelines for the Development of Biodiesel Standards in the APEC Region, Prepared by Hart Energy Consulting, a division of Hart Energy Publishing, November 2007.
- [9] Marcus Klein, "A Specific Heat Ratio Model and Compression Ratio Estimation"; Linkoping Sweden 2004.