

# A Study on the Modeling of Transient Response in Automated Manual Transmission for Hybrid Trucks

Kyung-Min Park\*\*† and Young-Jin Ko\*\*

(received 25 September 2013; revised 7 October 2013; and accepted 7 October 2013)

**Abstract** : Modern transmission technologies such as automated manual transmission(AMT) and dual clutch transmission(DCT) are interested to all manufactures due to their fuel efficiency and driver's convenience, especially in a hybrid system. AMT has advantages in that they have a high efficiency of manual transmissions(MT) and offer operation convenience similar to automatic transmissions(AT), but it has some disadvantages in that they have torque gap during gear shift and shift time. To reduce disadvantages, it is necessary to evaluate errors and characteristics as a developing simulation model before experimental verification. The purpose of this study is to develop virtual components and simulate the transient response of AMT. A dynamic AMT model and a control logic for an integrated vehicle model have been developed using Matlab/Simulink as a simulation platform. In this paper, the clutch model to describe the stick-slip transition mode and the transmission model to describe the neutral gear shifting is introduced and compared with each other.

**Key Words** : Automatic Manual Transmission, Clutch, Virtual Component, Gear Shifting, Hybrid Truck

## — Nomenclature —

$B_c$ : torsional damping coefficient of clutch, [Nm/deg]	$K_c$ : torsional stiffness of clutch, [Nm/deg]
$F_n$ : clutch clamp load, [N]	$\mu$ : friction coefficient
$I_c$ : clutch inertia, [kg • m <sup>2</sup> ]	$\dot{\omega}_c$ : clutch plates angular acceleration, [rad/s <sup>2</sup> ]
$R_o$ : clutch external radius, [m]	$\theta_c$ : clutch rotation angle, [rad]
$R_i$ : clutch internal radius, [m]	$\theta_t$ : transmission rotation angle, [rad]
$T_c$ : clutch torque, [Nm]	$i_g$ : Gear ratio
$n$ : clutch plates number	

## 1. Introduction

Transmission is largely classified into Manual Transmission(MT), Automated Transmission(AT), and Continuously Variable Transmission(CVT) depending on structural mechanism. Recently, automated manual transmission(AMT) which has advantages of high mechanical efficiency of power transmission in manual transmission and

\*† Kyung-Min Park : Project Planning Team, Jeonbuk Institute of Automotive Technology

E-mail : kmpark@jjat.re.kr, Tel : 063-472-2352

\*\*Young-Jin Ko : Advanced Technology Research Team, Jeonbuk Institute of Automotive Technology

transmission operation convenience in automated transmission.

Recently, AMT has been applied to commercial vehicles that are characteristic of slow acceleration and less torque interference as well as motorcar although its structure is complex and its development cost is high. In particular, with its expansion into hybrid(HEV) trucks and buses, AMT has been actively developed in Korean transmission companies. The core technologies of AMT include clutch control management(CCM) to automate clutch and automatic shifting gear(ASG) to automate transmission. In particular, shift quality is determined by clutch control method and dynamic performance can be implemented.

The automation of clutch aims to automate the clutch binding process by identifying a driver's intention to manipulate transmission and checking vehicle information, and plays a role of discontinuing and imparting the driving force of engine. The clutch control technology of AMT has disadvantages in that transmission time is somewhat long and shift quality is not good. To improve this, optimized transmission control technology is required under speedy gear shift, gear selection manipulation, and given vehicle operation condition.

Like this, it aims at a model base design that development cost and time saving are possible through advanced verification of operating error and control characteristics using a virtual evaluation model before applying the control algorithm to actual vehicle. Such a model based design has already been implemented in foreign advanced companies including Volkswagen and Benz, but we still lack of relevant technologies in Korea. Ju-Young Oh and Chang-Seop Song et al. had developed a simulation model that could evaluate transmission algorithm using a common tool MSC. EASY5.<sup>1-3)</sup>

This study aimed to analyze the dynamic characteristics of dry clutch in hybrid trucks and develop a dynamic system model in AMT in relation to its clutch clamping and separation process. In addition, this study aims to evaluate the discontinuous characteristics and transmission algorithm using simulation. Such AMT automatic control system made to reproduce transient behavior was developed in two types: clutch control module and transmission module. The results of simulation after analyzing the dynamic characteristics of system are reflected into the development of transmission algorithm.

## 2. AMT Model and Summary of Object Parts

The AMT model developed was composed of clutch module and transmission module. Final reduction gear, tire, etc excluding engines and AMT, of the models related to vehicle power transfer were configured using a commercial software, TruckSim. In addition, MATLAB/Simulink was the very model which was designed to interpret the dynamic behavior of AMT applying clutch and manual transmission data equipped into TruckSim interface module and 10-ton commercial vehicle.

Fig. 1 represents the schematic overview of a model developed.

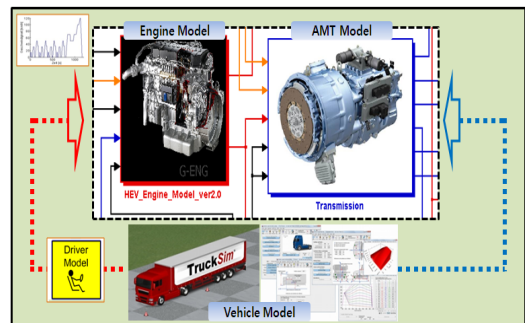

Fig. 1 Schematic overview of powertrain & vehicle model

## 2.1 Clutch of target clutch and transmission data

### 2.1.1 Clutch Data

There are a few of important parameters to obtain friction torque and transfer torque when modelling the dry clutch which was applied into a vehicle. As parameters used for clutch modeling, what was supplied to production companies was used and relevant detailed data was shown in Table 1.

Table 1 Specifications of dry clutch

Clutch	Value
Max. Clutch Torque (Nm)	1470
Inertia (kgf · m <sup>2</sup> )	0.057
Torsional damping (Nm/deg/s)	8
Torsional stiffness (Nm/deg)	K1(2.45)/K2(200.1)
Friction coefficient	0.247
Plates number (ea)	2
Internal radius (m)	0.12
External radius (m)	0.1975

The clutch model used maximum friction torque instead of replicating driver's pedal operation and considering displacement of clutch release cylinder. In addition, to calculate the torque depending on clutch displacement, the experimental results of release bearing and clamp load characteristics that correlate with vertical force are shown in Fig. 2. When calculating friction torque depending on

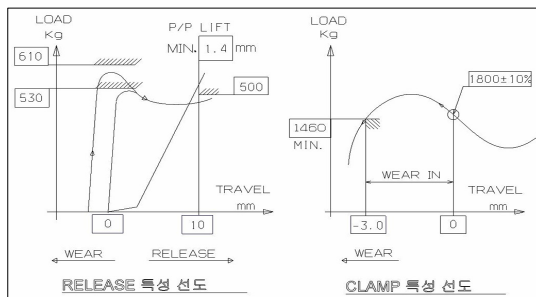

Fig. 2 Characteristics of clutch load

clutch motion, frictional coefficient was the constant obtained from an experiment to execute simulation.

### 2.1.2 Transmission Data

The transmission used in this study was the manual transmission that had six-speed gear position with rear-wheel drive and 98% of mechanical efficiency of power transmission. The detailed data such as gear ratio toward gear position, inertia, and efficiency were shown in Table 2.

To develop an AMT model, it is important to replicate the dynamic behavior of clutch above all. This study presents a mathematical model including control module and plant module in clutch system in the next chapter.

Table 2 Specifications of manual transmission

Gear	Gear Ratio	Inertia (kg · m <sup>2</sup> )	Efficiency (%)
1st	6.580	4.7455	98
2nd	3.922	1.6855	98
3rd	2.2257	0.5586	98
4th	1.441	0.2277	98
5th	1.0	0.1096	100
6th	0.735	0.0592	98
Rev.	6.061	4.0258	98

## 3. Clutch System Model

Clutch transmits engine power or makes the engine in no load state. It plays a role of delivering or cutting the torque delivered from the engine fly wheel. Thus, it plays an important role in interpreting dynamic behavior.

The schema of clutch movement structure and modelling range is shown in Fig. 3.

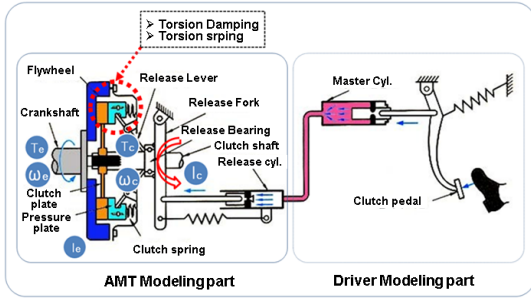

Fig. 3 Schematic plan of clutch system

To analyze the clutch movement mechanism and transmit power between engine and transmission gear box, we designed a model that was designed to calculate the clutch disk speed and torque and the engine speed was obtained using the difference between engine torque and clutch friction torque. In addition, it was modeled so that the transfer torque on transmission could be calculated depending on clutch speed. In general, equation of motions in vehicle speed-responding gear transmission process in clutch operation mechanism can be classified into three states. The transmission process depending on clutch movement can be presented as a basic control strategy of clutch model.

Fig. 4 represents the clutch separating process and the basic control concept.<sup>4)</sup>

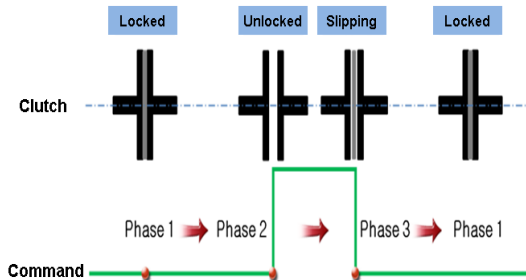

Fig. 4 Phase analysis for dry clutch modeling

State 1(phase 1): when clutch is completely

engaged,

State 2(phase 2): when clutch is completely separated,

State 3(phase 3): when clutch is slipped,

The clutch modelling that replicates the behavior in the clutch state depicted in the above designed slip state and locked state that occurred in the process of power transfer in formula(1), (2), and (3).

[phase 1]

$$(I_e + I_c)\dot{\omega}_c = T_e - [K_c(\theta_c - \theta_t) + B_c(\omega_c - \omega_t)]$$

$$\omega_e = \omega_c \tag{1}$$

[phase 2]

$$I_e\dot{\omega}_e = T_e$$

$$I_c\dot{\omega}_c = -[K_c(\theta_c - \theta_t) + B_c(\omega_c - \omega_t)] \tag{2}$$

[phase 3]

$$I_e\dot{\omega}_e = T_e - T_c$$

$$I_c\dot{\omega}_c = T_c - [K_c(\theta_c - \theta_t) + B_c(\omega_c - \omega_t)] \tag{3}$$

In AMT, clutch is an important device to determine shift quality. When transferring and disintegrating the engine power, torque and inertia section should be controlled appropriately. Therefore, accurate control technique is required to improve shift quality.

When gear transmission is required depending on vehicle operating speed, gear transmission process is temporarily in neutral condition before gear shift in the stage that clutch is separated engaged. To implement the clutch movement and gear transmission process like actual hardware is moving, we established clutch control strategy as shown in Fig. 5.<sup>5)</sup> To look at the strategy, first, gear transmission is required in the stage of clutch slip and if clutch separation order is transmitted from TCU, clutch begins to separate. Next is the clutch separation stage. At this time, engine

becomes in the no load state. Next is the gear transmission stage. When clutch is completely separated, gear transmission process starts in transmission gear box. The final stage is the clutch combination stage. If gear transmission is completed, clutch is engaged at this time.

Clutch moves for entire 1.5s and it's disengaged for 0.3s. Gear transmission is performed for 0.3s. Clutch is engaged for 0.9s.

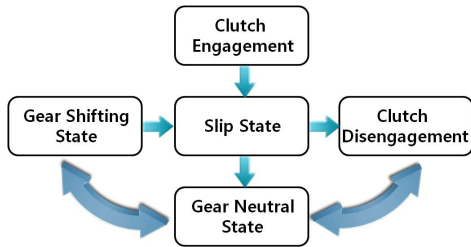

Fig. 5 Stateflow chart for clutch operation control

### 3.1 Clutch Disk Speed Calculation Model

Speed calculation of clutch disk is an important factor to reproduce dynamic behavior together with engine speed. It is essentially required to make an exact calculation of clutch transfer torque. Engine and clutch disk speed calculation was modelled by classifying the slip state and combing state depending on clutch movement and it was shown in Fig. 6.<sup>6)</sup>

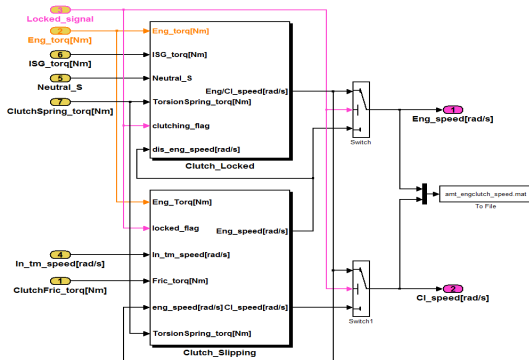

Fig. 6 Enging & clutch disk speed block

### 3.2 Clutch Transfer Torque Estimation Model

The clutch-associated torque can be classified into friction torque transferred from flywheel and transfer torque transferred from gear shift.

The vertical force that occurs by an operator when connecting clutch determines the transfer torque of clutch and can be expressed as shown in Formula(1) using frictional coefficient, number of valid contact surface, and effective radius of disk.<sup>7)</sup>

$$T_c = \frac{2}{3} \mu \cdot F_n \cdot n \frac{(R_o^3 - R_i^3)}{(R_o^2 - R_i^2)} \quad (4)$$

#### 3.2.1 Clutch Friction Torque Estimation Model

The areas that clutch friction occurs are clutch disk between flywheel and pressure plate, pre-damper, and main damper. Friction torque has hysteretic characteristics. This is why it is also called as hysteresis torque.

The friction torque of clutch can be divided into components in static state and in dynamic state. It's modelled by limiting statical friction torque, statical friction, and dynamic friction torque to the maximum friction torque of clutch. The statical friction torque of clutch was designed to make the engine and clutch disk speed almost the same and it was modelled so that the transient state can be interpreted when clutch transferred from slip state into combining state.<sup>8)</sup>

Fig. 7 represents a model that can be used to calculate the clutch friction torque transmitted to engine. If clutch movement signal is input, the maximum torque of clutch and the friction torque is calculated by damping and frictional coefficient.

#### 3.2.2 Clutch Torsional Torque Estimation Model

Clutch damper is consisted of free and main damper. Free damper works when angular

displacement of clutch disk and hub is small and has small stiffness and friction torque. While free damper works, main damper does not work. The angular displacement works beyond a certain limit. The stiffness and friction torque in main damper is designed to be higher than free damper. Table 3 and Table 4 represents typical values of angular displacement in two dampers and stiffness.<sup>9)</sup>

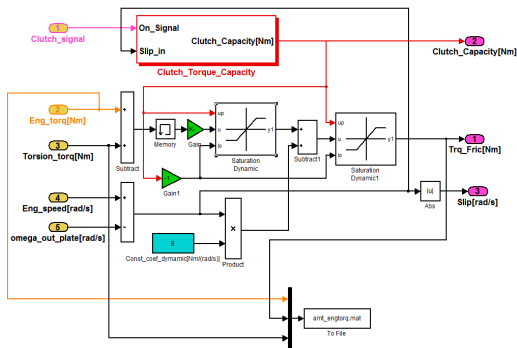

Fig. 7 Friction torque calculation block of clutch

Table 3 Stiffness & hysteresis parameters of the pre damper

	Unit	stiffness	hysteresis
$k_1$ ( $0 < \theta < 6$ )	kgf · m/ at 3°	0.52	0.3
$k_1$ ( $-4 < \theta < 0$ )	kgf · m/ at 3°	0.52	0.3

Table 4 Stiffness & hysteresis parameters of the main damper

	Unit	stiffness	hysteresis
$k_2$ ( $6 < \theta < 13$ )	kgf · m/ at 10°	20.4	0.3
$k_2$ ( $-11 < \theta < -4$ )	kgf · m/ at 10°	20.4	1~7

The damping spring between clutch disk and transmitter is non-linear and hysteretic. The clutch damping spring constants  $k_1$ ,  $k_2$  are the values that were calculated in an experiment. It was

linearized as shown in Fig. 8.

$$T_{stiff} = k_1 \theta \quad \text{if } (-4 \leq \theta \leq 6)$$

$$T_{stiff} = (k_1 \theta_{p1} + T_{pre}) + k_2 (\theta - \theta_{p1}) \quad \text{if } (6 < \theta \leq 13)$$

$$T_{stiff} = (k_1 \theta_{m1} - T_{pre}) + k_2 (\theta - \theta_{m1}) \quad \text{if } (-11 \leq \theta < 4)$$

$$T_{stiff} = [T_{p1} + k_2 (\theta_{p2} - \theta_{p1})] + k_{\infty} (\theta - \theta_{p2}) \quad \text{if } (-11 < \theta)$$

$$T_{stiff} = [T_{m1} + k_2 (\theta_{m2} - \theta_{m1})] + k_{\infty} (\theta - \theta_{m2}) \quad \text{else}$$

Herein,  $k_{\infty}$  is defined as  $150 \times 10^3$ .

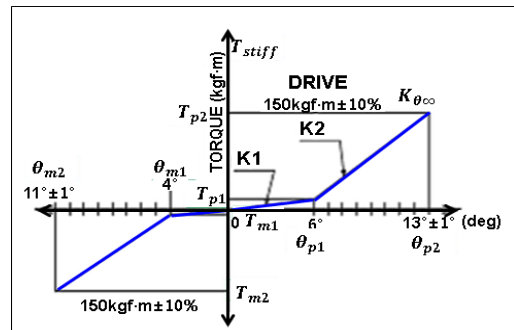

Fig. 8 Characteristics of clutch damper spring coefficient

Torsion torque is done by damping spring. It is defined as a function by spring characteristics, damping coefficient, and twisting angle. The model that considered this is shown in Fig. 9. And, Fig. 10 represents the overall clutch model.

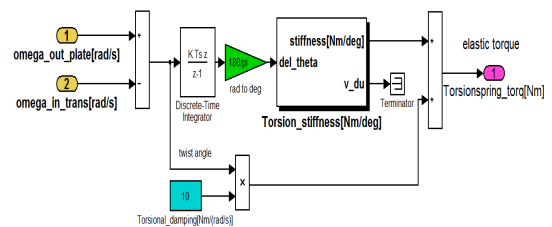

Fig. 9 Torsional torque calculation block of clutch

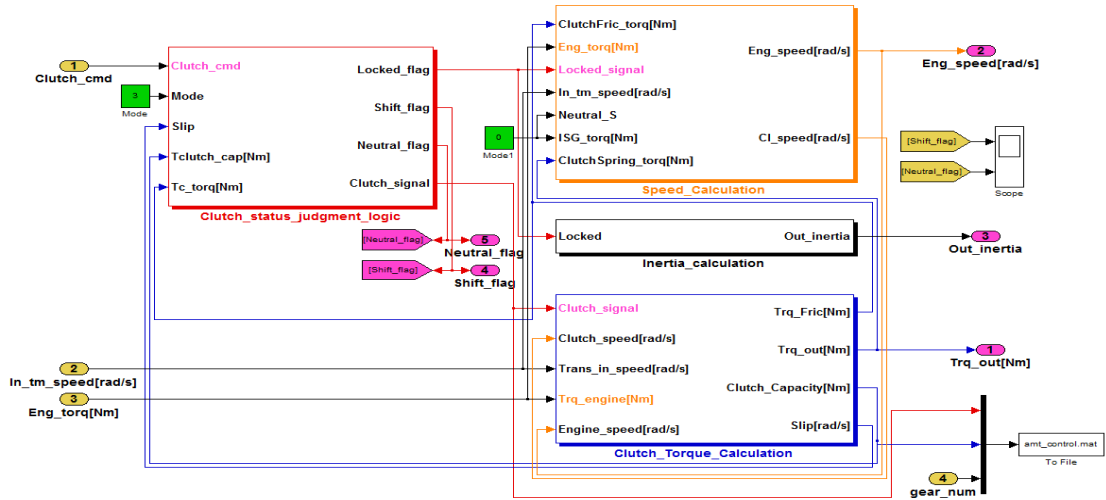

Fig. 10 Dry clutch model for automated manual transmission

#### 4. Transmission System Model

To convey the clutch power from differential gear to tire, we designed a model to calculate speed and torque depending on gear shift. We implemented a model that gear is shifted after being in neutral condition during change of speed and speed is reduced by considering inertia when it's in a neutral gear condition.

This transmission model is divided into control module which can control transmission under the transmission schedule logic and the model that calculates the transmission shear rate and latter torque depending on rear-wheel six-speed transmission and vehicle driving condition.

Transmission Control Unit(TCU) determines change gear steps depending on vehicle driving condition. We used Stateflow chart within module as shown in Fig. 11 and implemented it to determine the point of transmission and separate clutch from the clutch control module. We modelled it as a control block that outputs module and number of stages that are used to identify the up and down state of gear position.

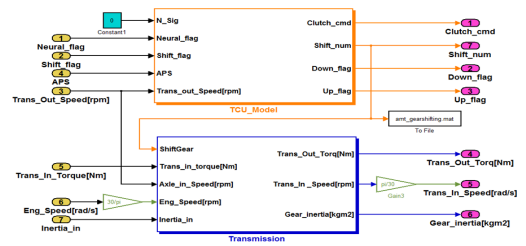

Fig. 11 Transmission model & gear shift schedule logic for TCU

#### 4.1 Transmission Gear Model

##### 4.1.1 Gearshift Output Terminal Speed Calculation Model

The transmission speed was inversely calculated in vehicle speed-based backward method in internal TruckSim model. The speed of the latter part in transmission is imparted to the transmission model. It was modelled as shown in Fig. 12 so that speed could be imparted to the clutch output terminal depending on gear ratio when changing speed and the relevant arithmetic expression is as shown in formula(5).

$$\omega_c = i_g \omega_t \tag{5}$$

Herein,  $i_g$  represents gear ratio.

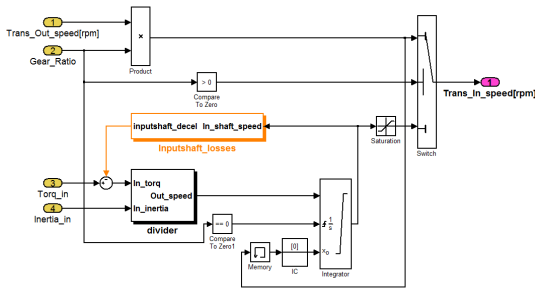

Fig. 12 Output speed calculation block of transmission

#### 4.1.2 Gearshift Output Terminal Torque Calculation Model

The torque delivered from clutch is calculated depending on transmission gear ratio and transmission efficiency. The inertia that belongs to each gear ratio is also applied. It is imparted to the TruckSim inner model. The model that considered the change gear ratio and gear shift efficiency depending on the gear transmission stages when changing speed is as shown in Fig. 13 by considering formula (6) and (7).

$$T_{out} = n_t \cdot i_t \cdot T_c \tag{6}$$

$$i_t = f(g) \tag{7}$$

Herein,  $n_t$  represents transmission efficiency,  $i_t$  inertia reflected into gear ratio.

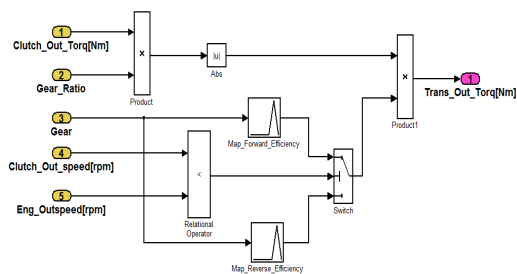

Fig. 13 Output torque calculation block of transmission

## 5. Simulation Result

This AMT dynamic behavior replication model used speed profile so that it could reach 50km/h of vehicle speed for 120s and examined the model validity by analyzing the speed and transfer torque of engine, clutch, and transmission.

Fig. 14 shows the simulation results regarding vehicle speed that follows the accel pedal values in driver's model and target vehicle speed. The low speed section shows some errors, but we can see that most followed it well.

Fig. 15 represents the results that controlled disengagement-engagement process by clutch control module. We can see that process of disengaging the clutch for 1.5s and making the gear in neutral position and changing speed depending on the order to disengage clutch.

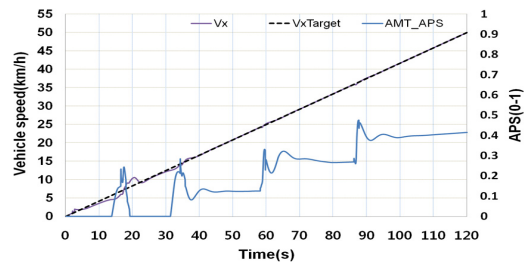

Fig. 14 Simulation results of APS & vehicle speed

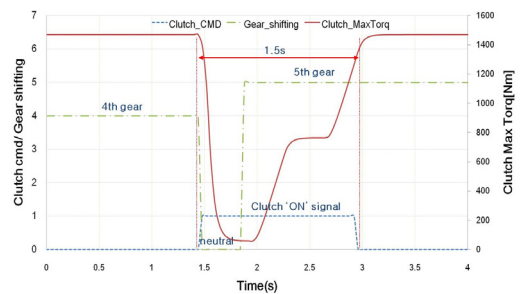

Fig. 15 Control strategy for clutch operation

Fig. 16 represents the speed change and conformability of engine and clutch depending on



clutch disengagement-engagement process. We can see that engine and clutch disk speed and gear are transmitted after being in neutral condition. In addition, the shock of changing speed at the point when transmission has been completed can be seen and the model needs to be complemented for the applicable values.

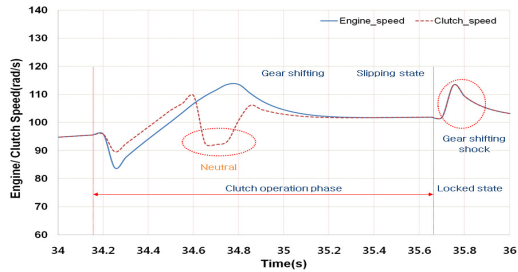

Fig. 16 Relative angular velocities of clutch engagement

Fig. 17 represents engine torque, clutch friction torque, and transfer torque transferred to transmission in the process of changing speed. We could see that behavior for neutral gear becomes consistent with the transfer torque values after transmission in the process of disengaging clutch power.

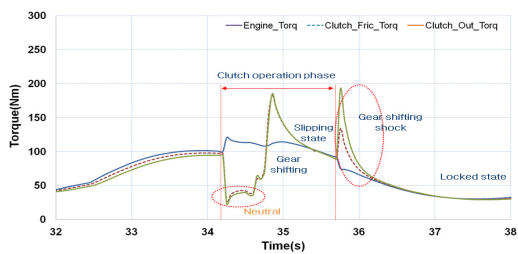
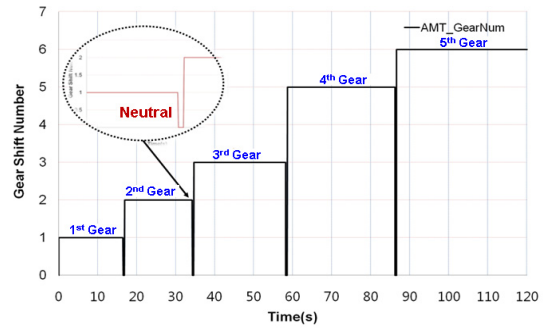

Fig. 17 Output torque during engagement

But, when gear stages are changed and engaged, it seems to be necessary to complement the model in terms of the magnitude of shock of changing speed and slip phenomenon that difference in torque occurs before separating clutch.

Fig. 18 shows the process that gear stages increase after being in neutral condition in the process of transmission.



## 6. Conclusions

This study implemented the model that could simulate dynamic behavior of AMT which has been actively developed recently. We developed a control module of AMT dynamic system and plant model by applying the actual parameters.

In addition, we used the interface provided by TruckSim to configure the vehicle simulator and could predict the AMT model performance including the impact on dynamic behavior and response characteristics in transient state depending on clutch and transmission control strategy.

1) AMT model can be divided into clutch model and transmission model. We represented the dynamic behavior in the process of changing speed and verified the model validity.

2) This model needs to be complemented in terms of detailed vehicle data and model in order to improve the accuracy which is close to the actual behavior based on the actual experimental results.

3) If AMT system can be developed, it is expected to be utilized as a model to develop TCU control logic.

## References

1. B. Kremmling and R. Fischer, 1998, " The Automated Clutch-The New Luk ECM", 6th International Luk Symposium, pp. 85-106.
2. C. H. Tseng and M. F. Hsieh, 2005, "Analysis and Optimization of Clutch Actuator on Automated Manual Transmission System," SAE 2005 Word Congress, SP 2005-01-178.
3. Y. O. Joo and S. S. Chang, "Development of Automated Mechanical Transmission Model to Evaluate TCU Control", Journal of the Korean Society for Precision Engineering, Vol. 27, No. 3, pp. 118-126
4. J. H. Park, W. J. Jang, S. T. Cho, J. M. Lee, H. S. Cho, 1996, "A Study on the dynamic characteristics of automated transmission clutch", Korean Society of Precision Engineering, pp. 325-329
5. M. S. Kim, C. W. Shin, W. S. Lim and S. K. Cha, 2010, "Development of Dry Clutch Dynamic Performance Model in a Commercial Vehicle" , KSAE Annual Conference, pp. 1512-1517
6. Argonne National Lab. PSAT User's Guide.
7. B. S. Lee, 2008, "Automotive Manual Transmission Clutches System Modeling for Foot Effort Hysteresis Characteristics Prediction" , Transactions of KSAE, Vol. 16, pp. 164-170.
8. ASM Vehicle Dynamics Reference User's Guide.
9. B. S. Lee, H. M. Shin and M. D. Hur, 2004, "Study on a Full-Size Tester for Manual Transmission Clutches", Transactions of KSAE, Vol. 12, pp. 101-109.