

Parsing the *Wh*-Interrogative Construction in Korean

Jaehyung Yang*[†]

Kangnam University

Jong-Bok Kim[‡]

Kyung Hee University

Jaehyung Yang and Jong-Bok Kim. 2013. Parsing the *Wh*-Interrogative Construction in Korean. *Language and Information* 17.2, 51–66. Korean is a *wh*-in-situ language where the *wh*-expression stays in situ with an obligatory Q-particle marking its interrogative scope. This paper briefly reviews some basic properties of the *wh*-question construction in Korean and shows how a typed feature structure grammar, HPSG (Pollard and Sag 1994, Sag et al. 2003), together with the notions of ‘type hierarchy’ and ‘constructions’, can provide a robust basis for parsing the *wh*-construction in the language. We show that this system induces robust syntactic structures as well as enriched semantic representations for real-time applications such as machine translation, which require deep processing of the phenomena concerned. (**Kangnam University and Kyung Hee University**)

Key words: *wh*-question, Q-particle, HPSG, implementation

1. Dependency between *Wh*-question and Q-particle

Unlike English, Korean is a *wh*-in-situ language where the *wh*-word stays in the original position (see Hagstrom 1998, Chung 1996, Kim 2000, Lee 2004, Hong 2005).

- (1) a. Mimi-ka nwukwu-lul manna-ass-ni?
 Mimi-NOM who-ACC meet-PST-QUE
 ‘Who(m) did Mimi meet?’
 b. Nwu-ka Mimi-lul manna-ss-ni?
 who-NOM Mimi-ACC meet-PST-QUE

* We thank three anonymous reviewers for comments and suggestions, which helped improve the quality of the paper a lot. Of course all mistakes or misinterpretations remain ours. This work was supported by the National Research Foundation of Korea Grant funded by the Korean Government (NRF-2011-32A-A00066).

[†] Kangnam University, Dept. of Computer and Media Information Engineering, 40 Kangnam-lo, Kihung-gu, Yongin-si, Kyonggi-do, 446-702, Korea, Phone: +82-31-280-3944, Email: jhyang@kangnam.ac.kr

[‡] Kyung Hee University, School of English, 26 Kyungheedae-ro, Dongdaemoon-gu, Seoul, 130-701, Korea, Phone: +82-2-961-0892, E-mail: jongbok@khu.ac.kr

‘Who(m) met Mimi?’

The *wh*-expression in Korean thus need not move to the clausal scope position (clause initial), though it can be optionally displaced to the position through a scrambling process:

- (2) mwues-ul Mimi-ka mek-ess-ni?
 what-ACC Mimi-NOM eat-PST-QUE
 ‘What did Mimi eat?’

As illustrated here, the *wh*-expression requires a question mood marking (Q-particle) like *-ni* on the matrix verb to have an interrogative meaning. Without such a Q-particle, the *wh*-expression can be interpreted as an indefinite pronoun (Chung 1996, Yoo 1997, Kim 2000, Hong 2005):

- (3) a. Mimi-ka mwues-ul mek-ess-ta
 Mimi-NOM what-ACC eat-PST-DECL
 ‘Mimi ate something.’
 b. Nwu-ka Mimi-lul manna-ass-ta
 who-NOM Mimi-ACC meet-PST-DECL
 ‘Someone met Mimi.’

The *wh*-expression is thus ambiguous between an interrogative reading and an indefinite reading, depending on its environment.

The Q-particle appears to the right of the corresponding *wh*-element to mark its scope (Suh 1989, Yoon 2004, Hong 2005). Observe the following:

- (4) a. Embedded clause *wh*-question
 Harry-nun [Mia-ka mwues-ul sa-ass-nunci] mwul-ess-ni?
 Harry-TOP Mia-NOM what-ACC buy-PST-QUE ask-PST-QUE
 ‘Did Harry ask what Mia bought?’
 b. Matrix clause *wh*-question
 Harry-nun [Mia-ka mwues-ul sa-ass-ta-ko] malha-yess-ni?
 Harry-TOP Mia-NOM what-ACC buy-PST-DECL-COMP say-PST-QUE
 ‘What did Harry say Mia bought?’

In both cases, the *wh*-question is in the embedded clause but the position of the Q-particle differs. In (4a), the Q-particle is in the embedded as well as in the main clause while in (4b) it is only in the matrix clause. This difference also yields difference in the interrogative scope: an embedded *wh*-question for (4a) and a main clause *wh*-question for (4b). From (4b), we can also observe that the Q-particle need not be in the same clause with the *wh*-question. It is thus the position of the Q-particle rather than the position of the *wh*-element that indicates the interrogative scope.

The language also allows multiple *wh*-questions:

- (5) a. John-un **nwu-ka mwues-ul** mek-ess-**nunci** mwul-ess-**ni**?
 John-TOP who-NOM what-ACC eat-PST-QUE ask-PST-QUE
 ‘Did John ask who ate what?’
- b. John-un **nwukwu-eykey** Mary-ka **mwues-ul** mek-ess-**nunci**
 John-TOP who-DAT Mary-NOM what-ACC eat-PST-QUE
 mwul-ess-**ni**?
 ask-PST-QUE
 ‘To whom did John ask what Mary ate?’

In (5a), the two *wh*-phrases are in the same clause, and the clause is interpreted as a multiple *wh*-question. In (5b), the two *wh*-phrases are in the different clause: one in the embedded and the other in the matrix with both clauses marked with the Q-particle. In this case, the whole clause is interpreted as a main clause *wh*-question with an embedded interrogative. Consider, unlike (5b), multiple *wh*-question sentences where the Q-particle is only in the matrix verb:

- (6) John-un **nwukwu-eykey** Mary-ka **mwues-ul** mek-ess-ta-ko
 John-TOP who-DAT Mary-NOM what-ACC eat-PST-DECL-COMP
 malha-yess-**ni**?
 say-PST-QUE
 ‘To whom did John say what Mary ate?’

The difference from (5b) is that there is only one Q-particle linked to the two *wh*-phrases in the embedded clause. This one has no embedded *wh*-question reading since the embedded clause has no Q-particle. The embedded *wh*-expression *mwues-ul* ‘what’ here can of course induce an indefinite reading.

2. Wh-questions and Indefinite

As noted, the *wh*-expression and the indefinite pronoun have the same form, implying ambiguous readings for sentences like (7):

- (7) mwue mek-ess-ni?
 what-(ACC) eat-PST-QUE
 ‘Did you eat something?/What did you eat?’

The prosodic difference on the sentence (LH pitch) gives us an indefinite reading while HL pitch generates a *wh*-interrogative reading.

The difference can also be marked on the *wh*-expression. The *wh*-expression is interpreted as an interrogative only when it has focus:

- (8) a. nwu-ka o-ass-ni?
 who-NOM come-PST-QUE
 ‘Did someone come?’
- b. NWU-ka o-ass-ni?
 who-NOM come-PST-QUE
 ‘Who came?’

The prosodic prominence is required to have an interrogative reading here. When the *wh*-expression is in the precopula position, we have only an interrogative reading (Chung 1996):

- (9) Mimi-ka ilk-un kes-i mwues-i-ni?
 Mimi-NOM read-PNE thing-NOM what-COP-QUE
 ‘What is it that John ate?/ *Is it something that John ate?’

When two *wh*-expressions appear in the same clause, they must receive the same interpretations (see Chung 1996, Kim 2000).¹

- (10) Nwuku-ka mwues-ul sa-ass-ni?
 who-NOM what-ACC buy-PST-QUE
 ‘Did someone buy something?’ ‘Who bought what?’
 ‘*Who bought something?’ ‘*What did someone buy?’

This implies that the *wh*-expression cannot be inherently interrogative or existential quantifier (see the next section for the discussion).

One thing to note here is that not all *wh*-expressions are ambiguous. For example, the *wh*-expression *way* ‘why’ has only an interrogative reading.

- (11) Mimi-ka way o-ass-ni?
 Mimi-NOM why come-PST-QUE
 ‘Why did Mimi come?’ ‘*Did Mimi come for some reason?’

This indicates that the *wh*-expression *way* ‘why’ is lexically specified to have only a *wh*-interrogative reading.

3. An Analysis

Before we discuss an analysis of *wh*-questions, consider a canonical, simple yes-no question:

- (12) Mimi-ka ttena-ass-ni?
 Mimi-NOM leave-PST-QUE
 ‘Did Mimi leave?’

In representing an yes-no question, we follow Ginzburg and Sag’s (2000) view that ‘questions’ are basic semantic entities such as individuals and propositions. Questions are distinguished from other messages in terms of a feature called PARAMS (parameters), whose set value is empty for yes-no questions but non-empty for *wh*-questions. That is, (12) would have a semantic representation like the following, roughly equivalent to $\lambda\{ \}[leave(m)]$:

¹ To some speakers including one anonymous reviewer, examples like (10) can induce all the readings given in the English translations.

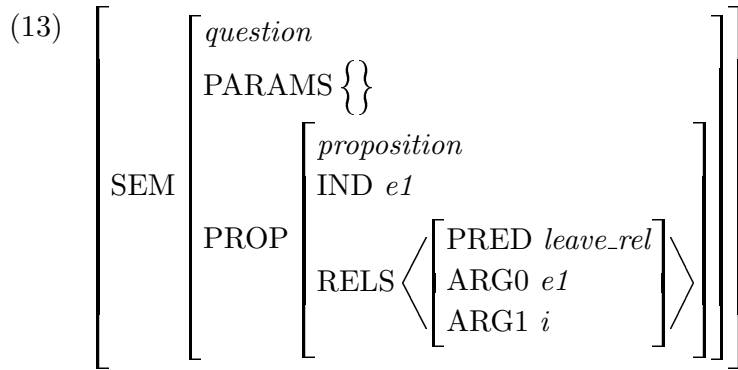

As represented here, the SEM type of a question has two attributes, PARAMS (parameters) and PROP (proposition). The attribute PARAMS introduces a set of index values for *wh*-interrogatives. For example, the *wh*-question (14a) will have the semantic feature representation in (14b), equivalent to $\lambda Qx[\textit{leave}(x)]$:

- (14) a. *nwu-ka ttena-ass-ni?*
 who-NOM leave-PST-QUE
 ‘Who left?’

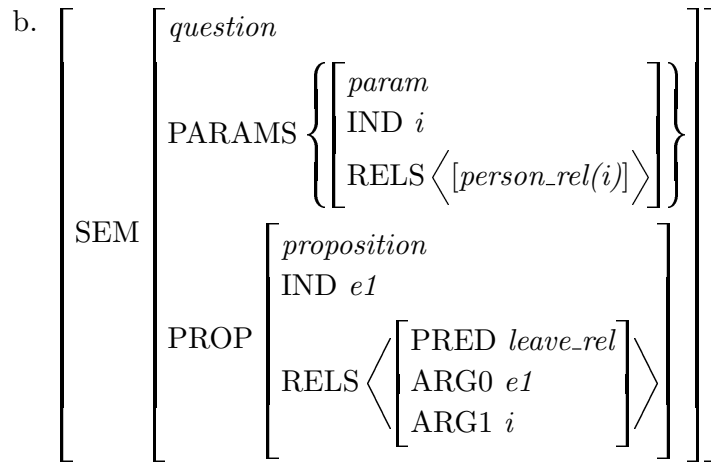

Each *wh*-question is thus treated as being about a proposition in question, with a set of parameters (or variables) to be determined in an answer. The elements in the PARAMS, introducing an index value (IND) and a semantic relation (RELS) placing restrictions on what the referent of the parameter refers to, correspond to the *wh*-words in a question, with each *wh*-word introducing one parameter. The feature PARAMS thus links the parameter for each *wh*-word to the semantic argument of a semantic relation (ARG1 of the *leave_rel* in (14b)).

As we have noted, the presence of a Q-particle on the matrix or on the embedded verb plays a key role in inducing an interrogative reading. This in turn means that the verb marked with a Q-particle would have lexical information like the following:²

² The attribute MOOD has values *decl(arative)*, *inter(rogative)*, *excl(amative)*, *imper(ative)*. The *decl* MOOD typically induces a propositional meaning, but note that there is no one to one mapping between MOOD and message types, *proposition*, *outcome*, *question*, *fact*.

- (15) a. Lexical information of *ttena-ass-ni* ‘leave-PST-QUE’:

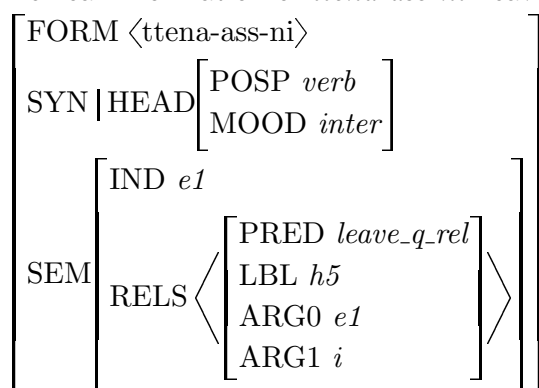

- b. Lexical information of the embedded interrogative verb *ttena-ass-nunci* ‘leave-PST-QUE’:

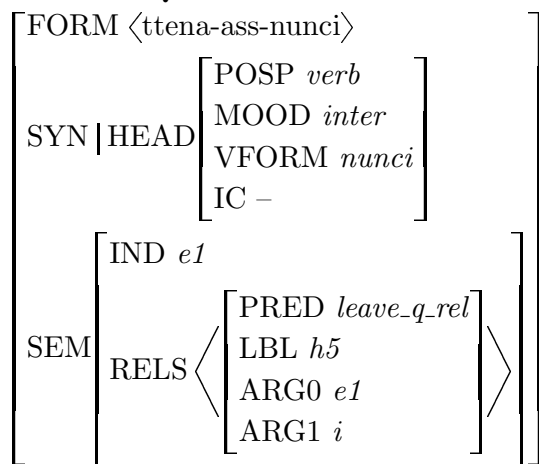

Given these, the language introduces a general constraint on the interrogative clause whose two main subtypes include yes-no and *wh*-interrogative constructions. This constructional constraint can be roughly represented as in (16):³

- (16) Interrogative Clause Construction (First Approximation):

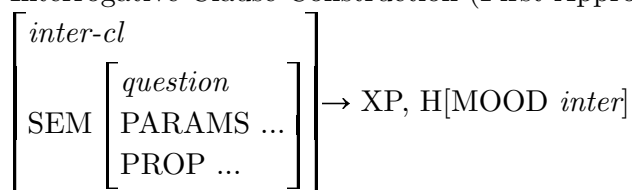

The constraint indicates the interrogative clause requires its head (the verb) to carry an interrogative MOOD value. The interrogative clause has at least two subtypes: yes-no (*polar-inter-cl*) and *wh*-questions (*wh-inter-cl*). As noted, as for the yes-no, the PARAMS value will be empty while for the *wh*-question, its value will be linked to the *wh*-word. Consider the lexical information of *nwukwu* ‘who’:

³ Yoo (1997) also offers a constraint-based analysis of Korean *wh*-interrogative constructions. Among the differences from Yoo’s syntactic analysis, the present analysis is a construction-based approach aiming at a computational implementation.

$$(17) \left[\begin{array}{l} \text{FORM } \langle \text{nwukwu} \rangle \\ \text{SYN } \left[\begin{array}{l} \text{HEAD } | \text{POSP } \textit{noun} \\ \text{WH } \langle ([\text{IND } x_4]) \rangle \end{array} \right] \\ \text{SEM } \left[\begin{array}{l} \text{IND } x_4 \\ \text{RELS } \left\langle \left[\begin{array}{l} \text{PRED } \textit{person_rel} \\ \text{LBL } h_3 \\ \text{ARG0 } x_4 \end{array} \right] , \left[\begin{array}{l} \text{PRED } \textit{which_q_rel} \\ \text{LBL } h_5 \\ \text{ARG0 } x_4 \\ \text{RESTR } h_6 \\ \text{BODY } h_7 \end{array} \right] \right\rangle \end{array} \right] \end{array} \right]$$

The lexical information specifies that the *wh*-word behave like an indefinite quantifier (generalized quantifier). This is similar to the idea that the *wh*-expression is a variable-type quantifier and its interpretation as a *wh*-interrogative is determined under binding by the licensing Q morpheme (cf. Yoo 1997). We have seen that the expression like *nwukwu* can be used either as an indefinite quantifier or as a *wh*-expression.

$$(18) \text{nwu-ka} \quad \text{o-ass-e} \\ \text{who-NOM} \quad \text{come-PST-QUE} \\ \text{'Did someone come?' or 'Who came'}$$

The optionality of linking the WH value to the index value of the *wh*-interrogative word in (17) allows the option. When the *wh*-word is linked to the nonlocal feature WH value, its value will be passed up to the mother, in accordance with the Nonlocal Feature Principle:

$$(19) \text{Nonlocal Feature Principle:} \\ \text{The nonlocal features including GAP and WH of a mother phrase is the} \\ \text{sum of the nonlocal features of all the daughters.}$$

The termination of the value of the attribute *WH* depends on the presence of Q-particle. As we have seen earlier, the main function of the Q-particle is to place the indefinite quantifier of the WH value in the PARAMS.

$$(20) \text{Interrogative Clause Construction (Final)} \\ \left[\begin{array}{l} \textit{inter-cl} \\ \text{WH } \{ \} \\ \text{SEM } \left[\begin{array}{l} \textit{question} \\ \text{PARAMS } \Sigma_1 \uplus \Sigma_2 \end{array} \right] \end{array} \right] \rightarrow \text{XP}[\text{WH } \Sigma_1] \quad \text{H} \left[\begin{array}{l} \text{MOOD } \textit{inter} \\ \text{WH } \Sigma_2 \end{array} \right]$$

This constructional constraint ensures that the values of the nonlocal feature WH in the head as well as nonhead daughter of the interrogative clause will be linked

to the PARAMS value so that it can be interpreted as a *wh*-question.⁴ In doing so, the head daughter needs to have the Q-particle marking (the interrogative MOOD value) and the mother's WH value will be terminated. The reason for the latter will be seen in what follows. To see how the system works, consider the structure of (1a) 'Who did Mimi meet?' it generates:

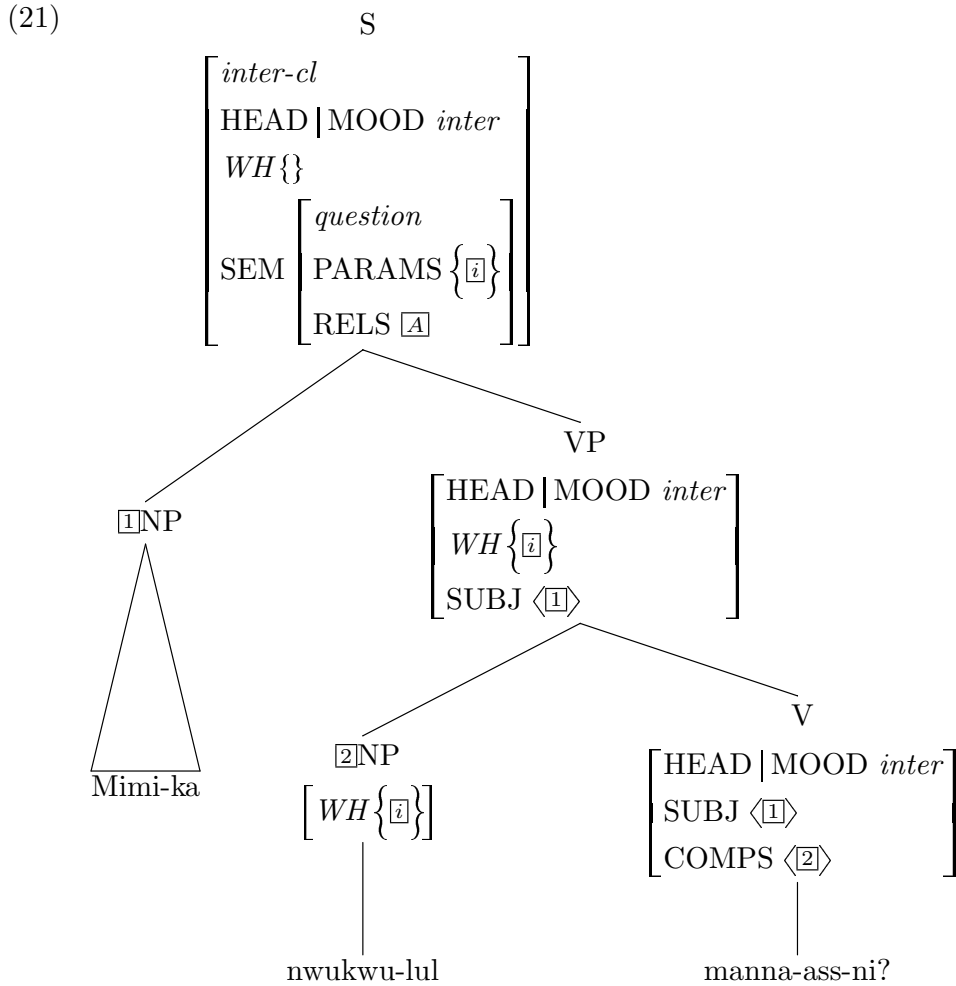

⁴ To be more precise, we need a unary rule. That is, the WH value is first passed up to the interrogative clause construction and a unary rule like the following moves the WH values to the PARAMS value:

(i) Interrogative Clause Interpretation

$$\left[\begin{array}{l} \textit{inter-cl} \\ \textit{WH} \{ \} \\ \textit{SEM} \left[\begin{array}{l} \textit{question} \\ \textit{PARAMS} \Sigma_1 \uplus \Sigma_2 \end{array} \right] \end{array} \right] \rightarrow \left[\begin{array}{l} \textit{inter-cl} \\ \textit{MOOD} \textit{inter} \\ \textit{WH} \Sigma_1 \\ \textit{SEM} \left[\textit{question} \right] \end{array} \right]$$

In our implementation, this unary rule is also introduced with the slight revision of the rule in (20).

The structure illustrates that the value of the attribute *WH* evoked from the *wh*-expression *nwukwu-lul* ‘who-ACC’ is passed up to the VP. But this value is terminated at the S-level (*inter-cl*) by being linked to the value of *PARAMS*, which induces a *wh*-interrogative reading.

The analysis will easily predict multiple *wh*-questions too. For example, a sentence like (22a) will have a structure like (22b):

- (22) a. *nwu(kwu)-ka mwues-ul mek-ess-ni?*
 who-NOM what-ACC eat-PST-QUE
 ‘Who ate what?’

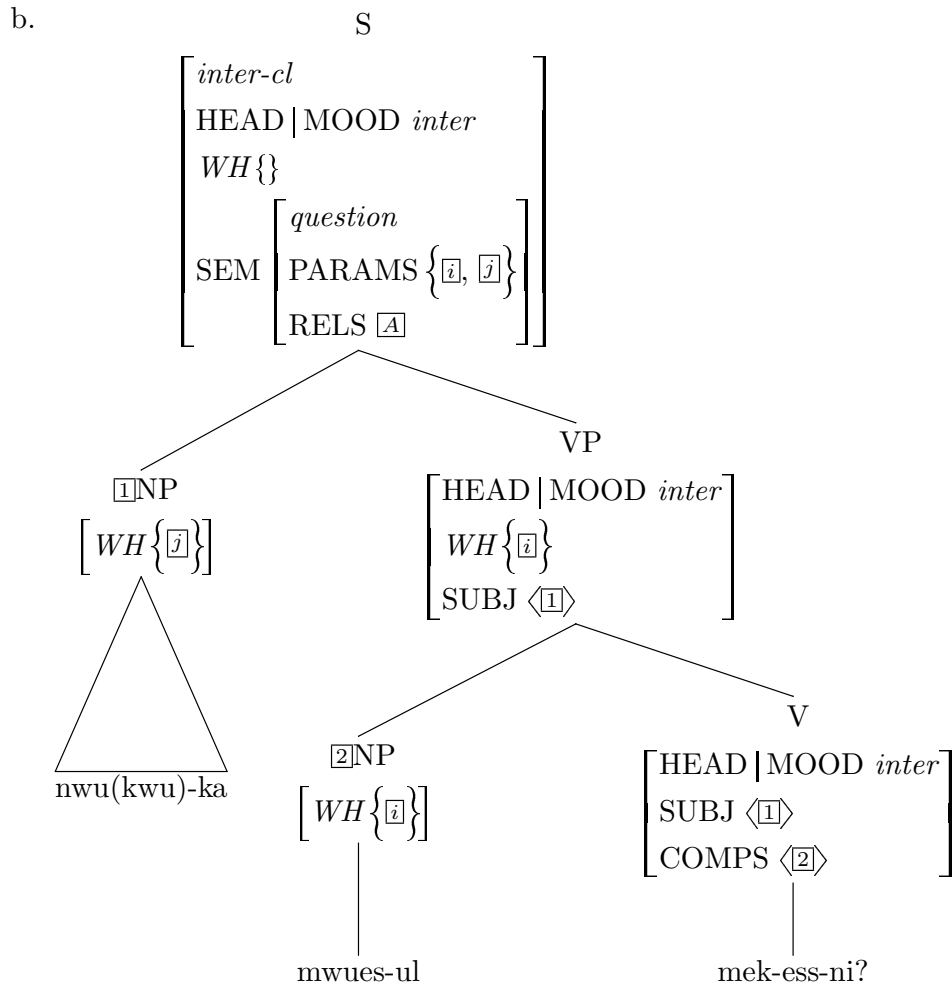

As represented in the tree, each of the *wh*-expression contributes to the *WH* value, percolated up to the top node and then moved to the *PARAMS* value. This is why we have two members in the *PARAMS* value linked to the subject and object *wh*-expressions. These two values are discharged together and that’s why we do not induce a reading in which only one of the two *wh*-expressions is indefinite and the other is a *wh*-interrogative reading.

Since the *WH*-feature is taken to be a nonlocal feature, we can account for the nonlocal nature of *wh*-interrogatives. Consider the structure of (23a) in (23b):

- (23) a. Mimi-ka nwu-ka ttena-ass-ta-ko sayngkakha-ni?
 Mimi-NOM who-NOM leave-PST-DECL-COMP think-QUE
 ‘Who does Mimi think left?’

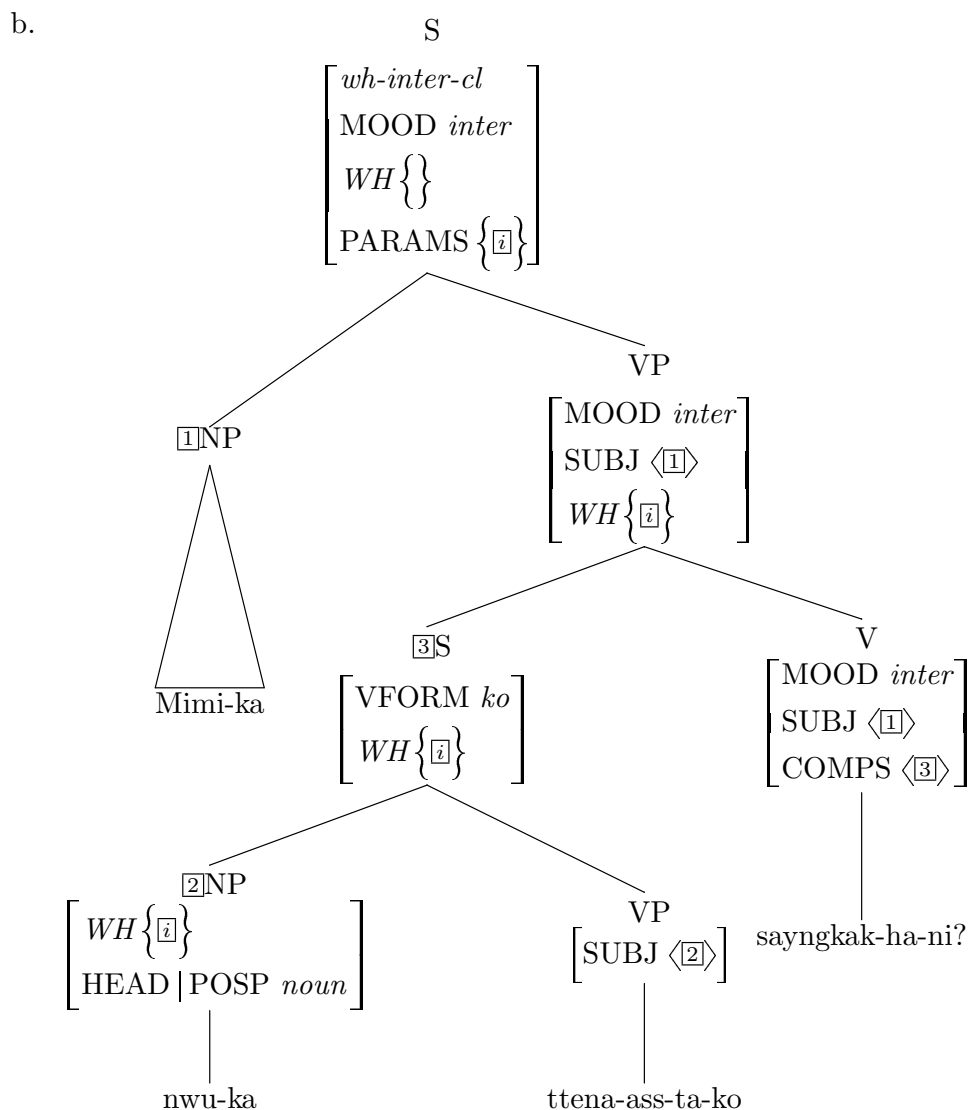

In the sentence, the Q-particle marks the matrix clause with the *wh*-expression in the embedded, and the whole sentence is interpreted as an interrogative. The *WH*-value in the embedded clause will be passed up to the point it is terminated or linked by a Q-particle. This is why we have a matrix-clause question in this case.

When the Q-particle marks both the embedded and matrix clause, the *wh*-expression is interpreted under the nearest question:

- (24) Mimi-nun nwu-ka ttena-ass-nunci al-ni?
 Mimi-TOP who-NOM leave-PST-QUE know-QUE
 ‘Does Mimi know who left?’ ‘*Who does Mimi know leave?’

The present system can account for this in a simple manner. The *wh*-expression *nwu-ka* ‘who-NOM’ evokes a *WH*-value, and this value cannot pass up to the matrix clause because the embedded clause’s verb *ttena-ss-nunci* is marked with a Q-particle. This enforces its value to be moved to the PARAMS value, as seen from the following tree structure:

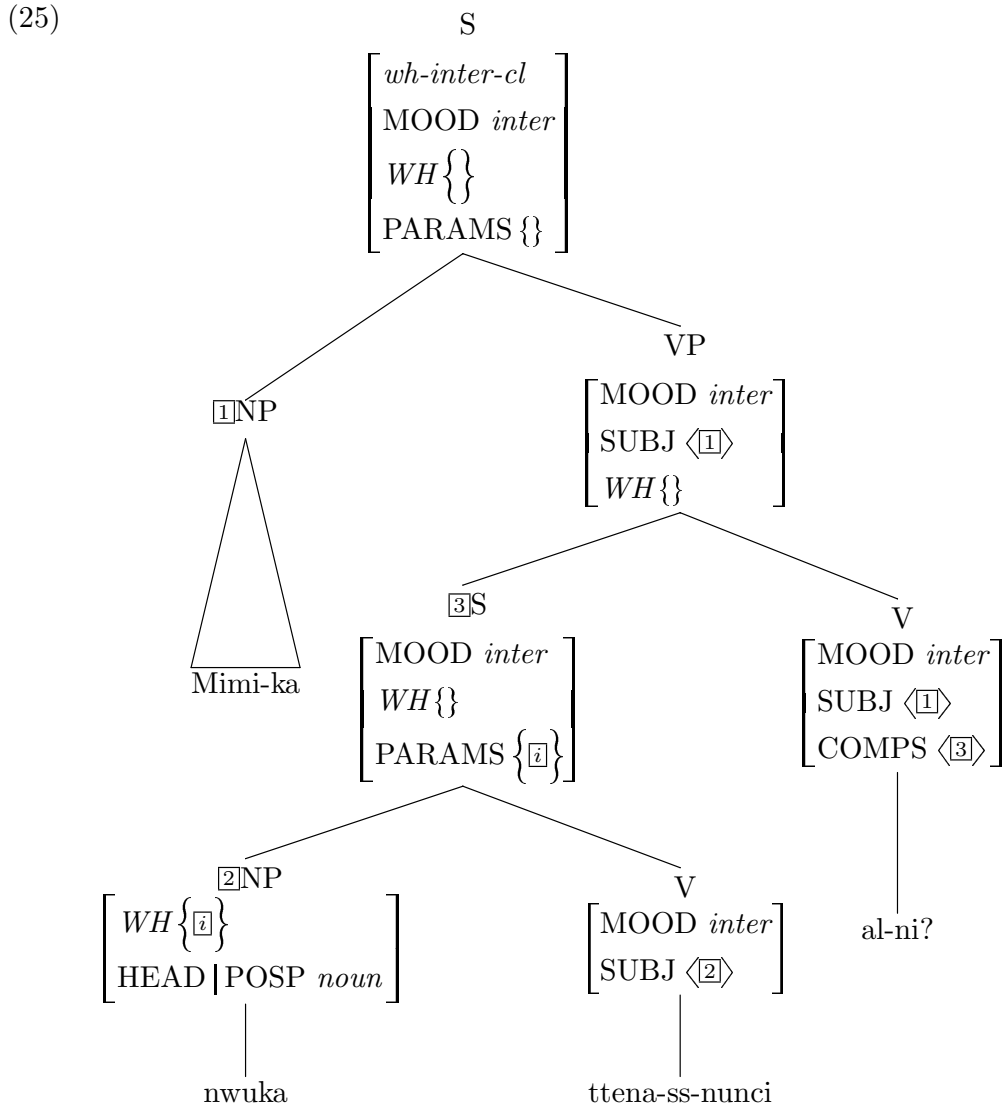

When the *WH*-value meets the Q-particle (MOOD value), its value is moved to the PARAMS value, inducing a *wh*-interrogative reading. This is why we have only the embedded *wh*-reading in such a case. As we have seen in (20), the *WH* value is empty in the interrogative clause level. This implies that once the head daughter of the clause in question is marked with the Q-particle, the *wh*-expression needs to be interpreted at this level, without passing up to a higher position further.

4. A Computational Implementation

The analysis we have presented so far has been incorporated in the typed-feature structure grammar HPSG for Korean (Korean Resource Grammar) aiming at working with real-world data (see Kim 2004, Kim and Yang 2011). To test its performance and feasibility, it has been implemented into the LKB (Linguistic Knowledge Building) system developed by Copestake (2002).⁵ The test results give the proper syntactic as well as semantic structures for the test sets of the Korean *wh*-question construction in question.

For example, Figure 1 is the syntactic structure and MRS (Minimal Recursion Semantics) representations for the simple *wh*-question (1a) *mimi-ka nwukwu-lul manna-ss-ni* ‘Who did Mimi meet?’.⁶

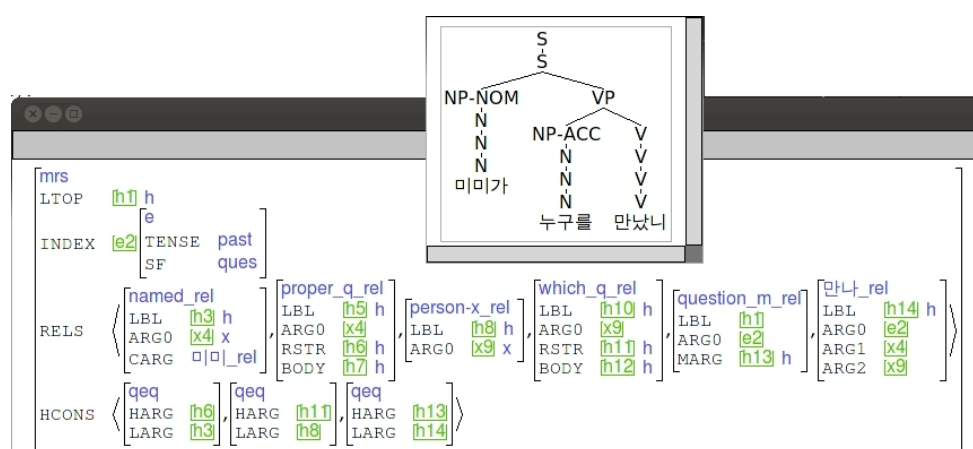

[Figure 1] Parsed Tree and MRS for the ‘Who did Mimi meet?’ in Korean

The syntactic structure is a simple binary one, and the MRS the grammar generates provides enriched information of the phrase. The value of LTOP is the local top handle, the handle of the relation with the widest scope within the constituent. The attribute RELS is basically a bag of elementary predications (EP) each of whose value is a *relation*.⁷ Each of the types *relation* has at least three features LBL, PRED (represented here as a type), and ARG0. The INDEX value here is identified with the ARG0 value of the semantic head (e.g., verb).

In Figure 1, the MRS structure gives us a quantifier reading for the *wh*-object *nwukwu-lul* ‘who’ with the two predicate relations *person-x-rel* and *which-q-rel*. The index of this expression becomes the value of the nonlocal feature WH and then moves to the PARAMS value to be interpreted as the matrix question when it meets the Q-particle. The output of the interpretation is thus almost equivalent as

⁵ The current Korean Resource Grammar (KRG) has 487 type definitions, 46 grammar rules, 89 inflectional rules, 2368 lexical entries, and 2100 test-suite sentences, and aims to expand its coverage on real-life data. See Kim et al. (2011).

⁶ For the discussion of the MRS system, see Copestake et al. (2005) Kim (2006).

⁷ The attribute HCONS is to represent quantificational information. See Copestake et al. 2004 for details.

the following:

$$(26) \lambda Qx[\text{meet}(m,x)]$$

The system can also parse multiple *wh*-questions in a straightforward manner. Figure 2 is the output syntactic and MRS representations of the multiple *wh*-question (22a), *Who ate what?*

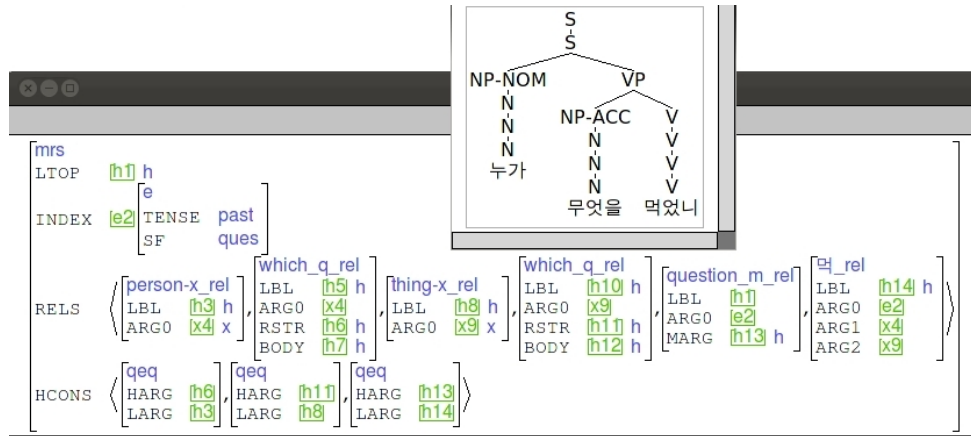

[Figure 2] Parsing results of ‘Who ate what?’ in Korean

As seen from Figure 3, the two *wh*-expressions contribute to the value of the PARAMS, resulting in the proper multiple *wh*-question interpretations. This can be evidenced from the AVM structure of the parsed structure:

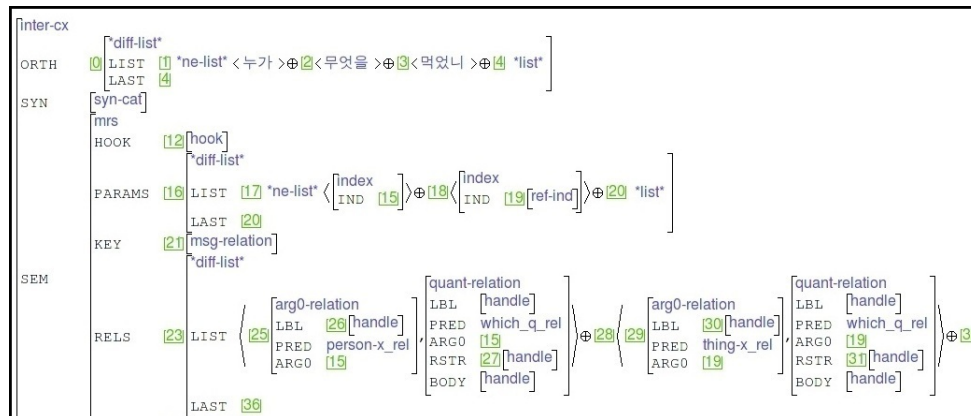

[Figure 3] PARAMS value of ‘Who ate what?’ in Korean

What we can observe from the AVM structure of this sentence is that the two index values (15 and 19) in the PARAMS are linked to the two *wh*-expressions, respectively, giving us a proper interpretation for the multiple *wh*-question.

The present system offers a proper parsing result for the embedded matrix example (24). The sentence ‘Does Mimi know who left?’ is an embedded question marked by the Q-particle. This means that the WH value evoked by the *wh*-expression in the embedded clause has scope over the embedded clause only. This output is reflected in the parsing results in Figure 4.

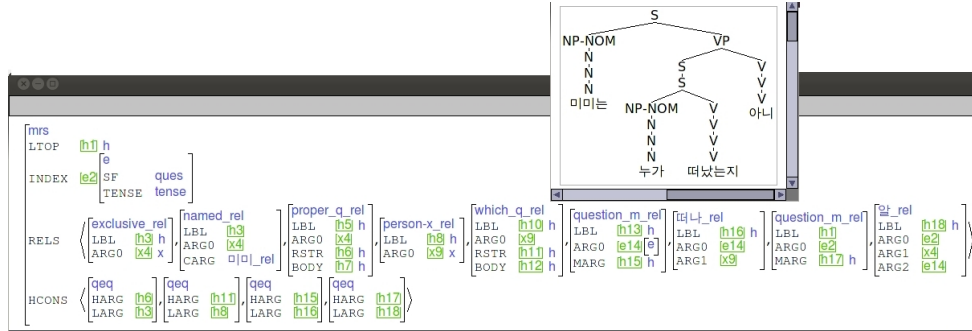

[Figure 4] Parsing results of ‘Does Mimi know who left?’ in Korean

Of course, the present system also accounts for cases where the *wh*-expression in the embedded clause scopes over the matrix clause marked by the Q-particle. The following is the output of the sentence (23), meaning ‘Who does Mimi think left?’

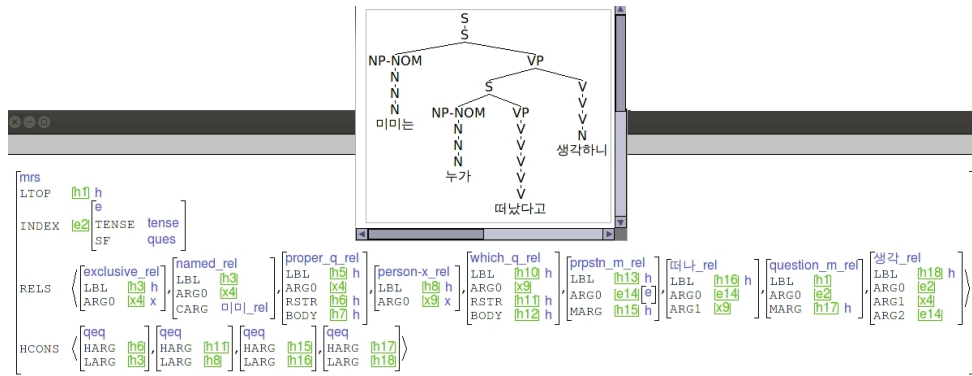

[Figure 5] Parsing results of ‘Who does Mimi think left?’ in Korean

This sentence represents a matrix *wh*-question initiated from the embedded clause. The information of the *wh*-expression in the embedded clause is passed up to the matrix clause and interpreted there by the Q-particle at the matrix clause.

As seen from here, the PARAMS value is linked to the *wh*-expression in the embedded clause, inducing a correct scope for the *wh*-question.

5. Conclusion

As we have seen in the previous discussion, Korean *wh*-elements typically stay in their canonical positions with an overt case marking. The grammatical function and

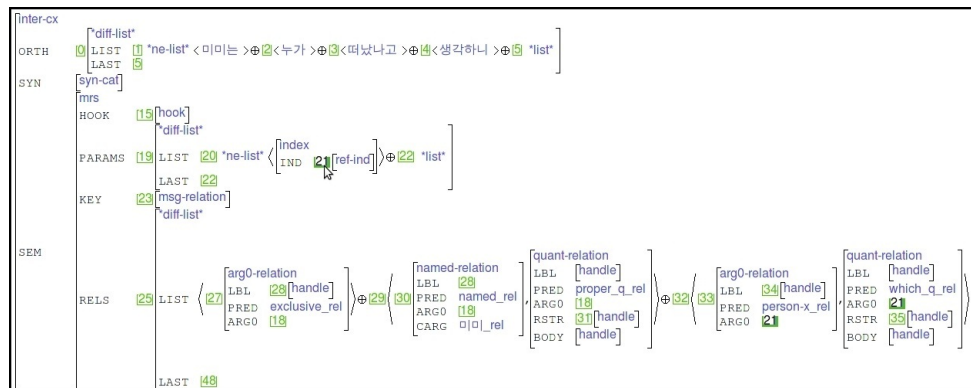

[Figure 6] PARAMS value of the sentence ‘Who does Mimi think left?’ in Korean

semantic role of a *wh*-expression is at large unambiguous. However, its interrogative scope is ambiguous since its scope is determined by the Q-particle of the matrix verb at a remote position.

In this paper, we have offered an HPSG analysis where the *wh*-expression presents a variable-type quantifier which can be optionally contributed to the non-local feature *WH*. Depending on this, the *wh*-expression can be interpreted either as an indefinite quantifier or as *wh*-interrogative expression. That is, *wh*-expressions are actually indefinite quantifiers, and the interrogative reading of *wh*-expressions is derived by some mechanism. The analysis places an importance of interactions among lexical information and constructional constraints. Though there still remains several issues in the computational implementation (including how to reflect the prosodic properties in determining an indefinite or interrogative reading), we can see a promising direction for the deep processing of Korean *wh*-constructions.

References

Chung, Daeho. 1996. On the representation of Q and Q-dependencies. Ph.D. Dissertation, University of Southern California.

Copestake, Ann. 2002. *Implementing Typed Feature Structures*. Stanford: CSLI Publications.

Copestake, Ann, Dan Flickinger, Carl Pollard, and Ivan A. Sag. 2005. Minimal Recursion Semantics: an Introduction. *Research on Language and Computation* 3.4: 281–332.

Flickinger, Dan. 2000. On building a more efficient grammar by exploiting types. *Natural Language Engineering* 6(1): 15–28.

Ginzburg, Jonathan, and Ivan A. Sag. 2000. *Interrogative Investigations: The form, meaning and use of English interrogatives*. Stanford, CA: CSLI Publications.

Hagstrom, Paul. 1998. *Decomposing Questions*, Ph.D Dissertation. MIT.

- Hong, Sun-Ho. 2005. Aspects of the Syntax of Wh-Questions in English and Korean. Ph.D Dissertation, University of Essex.
- Kim, Jong-Bok. 2004. *Korean Phrase Structure Grammar*. (In Korean). Seoul: Hankwuk Publisher.
- Kim, Jong-Bok. 2006. Minimal Recursion Semantics: An Application into Korean. *Journal of the Linguistic Association of Korea* 14.2: 59–85.
- Kim, Jong-Bok, Jaehyung Yang, Sanghoun Song, and Francis Bond. 2011. Deep Processing of Korean and the Development of the Korean Resource Grammar. *Linguistic Research* 28.3, 635-672.
- Kim Ae-Ryung. 2000. Korean Wh-phrases Void of Operator. In Mineharu Nakayama and Charles J. Quinn (eds.), *Japanese/Korean Linguistics* 9, 311-324.
- Lee, Yong-hun. 2004. A Computational Approach to Questions: Examples from Korean. *Studies in Generative Grammar*, 14: 39–58.
- Pollard, Carl and Ivan A. Sag. 1994. *Head-Driven Phrase Structure Grammar*. CSLI Publications and University of Chicago Press.
- Sag, Ivan A., Wasow, Thomas and Bender, Emily M. 2003. *Syntactic Theory: A Formal Introduction*. 2nd ed., Stanford: CSLI Publications, Stanford.
- Suh, Chung-Mok. 1989. WH-constructions in Korean. In Susumu Kuno *et al.* (eds.), *Harvard Studies in Korean Linguistics* 3: 517–526.
- Yoon, Jeongme. 2004. Unified clausal approach wh-constructions in Korean revisited: an analysis based on reanalysis. *Studies in Generative Grammar* 4: 3-38.
- Yoo, Eun-Jung. 1997. Quantifiers and Wh-interrogatives in the Syntax-Semantics Interface. Ph.D Dissertation, Ohio State University.

Submitted on: October 21, 2013

Revised on: November 22, 2013

Accepted on: December 16, 2013