

Centralized Adaptive Under Frequency Load Shedding Schemes for Smart Grid Using Synchronous Phase Measurement Unit

D. Y. Yang[†], G. W. Cai^{*}, Y. T. Jiang^{*} and C. Liu^{**}

Abstract – Under frequency load shedding (UFLS) is an effective way to prevent system blackout after a serious disturbance occurs in a power system. A novel centralized adaptive under frequency load shedding (AUFLS) scheme using the synchronous phase measurement unit (PMU) is proposed in this paper. Two main stages are consisted of in the developed technique. In the first stage, the active power deficit is estimated by using the simplest expression of the generator swing equation and static load model since the frequency, voltages and their rate of change can be obtained by means of measurements in real-time from various devices such as phase measurement units. In the second stage, the UFLS schemes are adapted to the estimated magnitude based on the presented model. The effectiveness of the proposed AUFLS scheme is investigated simulating different disturbance in IEEE 10-generator 39-bus New England test system.

Keywords: Under frequency load shedding, Power system under frequency protection, Synchronous phase measurement, Smart grid

1. Introduction

UFLS scheme must be efficient, robust, fast and simple since the UFLS is the last protecting step to prevent power system blackouts and severe damages [1-2]. But several noticeable blackout accidents [3], such as August 2003 blackout in US and Canada, have occurred worldwide. Various reasons have been declared for these failures. Invalid design of traditional load shedding scheme depending only on the local measurement is one of the most important reasons initiating these blackouts [4].

The conventional UFLS plans [5-6] derived from assuming system condition and load distributions is designed to reduce power mismatches following a generator or tie-line outage or sudden load increase. In this approach, whenever the frequency falls below the set point, the relay acts to shedding some parts of the system loads in a few steps. The UFLS scheme parameters, i.e., frequency thresholds, step sizes and time delay, are preselected and based on simulation results and operator's experience in the conventional UFLS plans. The system state, topology and the magnitude of the disturbance cannot be taken into account adaptively. The other major deficiencies in the conventional UFLS plan are that a system view cannot be considered and are therefore not able to take optimized and coordinated. In other words, always, the UFLS plans were not able to be updated according to the disturbance and the

actual system status [7].

In modern power system, the application of Wide Area Measurement System (WAMS) via PMU have influenced the future of development of advanced technique implemented in electrical power engineering, particularly in the power system measurement, monitoring, protection and control [8]. The WAMS will be a solution of the smart grid [9, 10] implementation. And WAMS for smart grid applications involves the system wide monitoring, assessment and control.

With the advent of WAMS, the centralized AUFLS that used frequency values from different parts of the overall system as inputs became widespread [11-12]. In these centralized AUFLS schemes, the required information is transmitted to the control center, and then the magnitude of the generation-load imbalance is estimated and distributed to the different location. Theoretically, the centralized AUFLS schemes should be able to select frequency thresholds and time delay as well as the amount and location of loads to be shed. However, the current centralized AUFLS schemes are mainly focusing on the technique used to estimate the magnitude of the disturbance. The influences produced by the uncertainties in system, such as system losses, are basically absent [13].

Nowadays, the interconnected power system is becoming more and more related to each other; besides, the frequency regulation effect of loads is also becoming more and more obvious. It is clear that the appropriate amount of load to be shed can be more beneficial to system frequency recovery and system stability.

In this paper, a novel centralized AUFLS scheme using PMU is proposed. A mathematical model in which the loads characteristics are inserted for the estimation of the

[†] Corresponding author: School of Electrical & Electronic Engineering, North China Electric Power University, China. (eedyang@hotmail.com)

^{*} School of Electrical Engineering, Northeast Dianli University, China. (caigw@mail.nedu.edu.cn)

^{**} School of Electrical & Electronic Engineering, North China Electric Power University, China. (caigw@mail.nedu.edu.cn)

Received: July 10, 2012; Accepted: December 4, 2012

magnitude of the disturbance will be developed and tested through the simulation of a test power system. Then the uncertainties in the system are considered in the proposed AUFLS schemes.

This paper is organized as follows: In section 2, the model for estimation of the active power deficit using PMU is proposed. The determination model for AUFLS activation is developed in section 3. Section 4 describes the proposed centralized AUFLS schemes. Several case studies are carried out in Section 5 to evaluate the effectiveness of the proposed AUFLS schemes. Finally, conclusions are given in Section 6.

2. Model for Estimation of Active Power Deficit

2.1 Active power deficit from frequency response of generators

The model for estimation of active power deficit from the frequency response of generators has been proposed in [11]. For this purpose, disturbance power is computed from the initial rate of change of frequency measured utilizing the PMU. The swing equation of the i th generator with inertia constant, H_i , is written as:

$$\frac{2H_i}{f_n} \frac{df_i}{dt} = P_{mi} - P_{ei} = \Delta P_{gi} \quad (i=1, \dots, N_g) \quad (1)$$

Where N_g is the number of generators, P_{mi} is the mechanical turbine power in p.u, P_{ei} is the electrical power in p.u, ΔP_{gi} is the imbalance active power between generation and consumption in p.u, f_i is the frequency in hertz and f_n is its rated value.

So the total active power deficit is given by

$$\Delta P_g = \sum_{i=1}^{N_g} \Delta P_{gi} = \frac{2}{f_n} H_c \frac{df_{coi}}{dt} \quad (2)$$

Where

$$H_c = \sum_{i=1}^{N_g} H_i \quad (3)$$

$$f_{coi} = \frac{\sum_{i=1}^{N_g} H_i f_i}{H_c} \quad (4)$$

Where f_{coi} is the frequency at the center of inertia (COI), H_c is the equivalent inertia constant for the entire system.

The major shortcoming of using (2) for estimation active power deficit which would be shed in UFLS is that the variation of active power loads due to voltage

fluctuation is not included. Consequently, the load's voltage dependence has been considered specially in the published papers [13-14]. We will draw attention to the active power loads changing due to voltage fluctuation.

2.2 Active power loads changing because of voltage deviations

At present, lots of load models (constant power and/or constant current and/or constant impedance) are used in power load flow, transient stability studied and system control [14-15]. Excellent formulation can predict system performance more accurately. Static load model [1] is the most mature and representative in power system studies, and it is also widely used in power system frequency analysis and control. The static load model in this paper is:

$$P_{L,i} = P_{L0,i} \left[a_{p,i} \left(\frac{V_i}{V_{i0}} \right)^2 + b_{p,i} \left(\frac{V_i}{V_{i0}} \right) + c_{p,i} \right] (1 + k_{p,i} \Delta f_i) \quad (5)$$

$$Q_{L,i} = Q_{L0,i} \left[a_{q,i} \left(\frac{V_i}{V_{i0}} \right)^2 + b_{q,i} \left(\frac{V_i}{V_{i0}} \right) + c_{q,i} \right] (1 + k_{q,i} \Delta f_i) \quad (6)$$

where $P_{L,i}$ and $Q_{L,i}$ are the case active and reactive load power at bus i , Δf_i is the frequency deviation, $k_{p,i}$ and $k_{q,i}$ are the active and reactive frequency sensitivity factors, $a_{p,i}$, $b_{p,i}$, $c_{p,i}$, $a_{q,i}$, $b_{q,i}$, $c_{q,i}$ are the active and reactive voltage sensitivity factors, respectively.

Through the linearization of equation (5), the imbalance active power supplied by load at bus i can be determined as:

$$\Delta P_{L,i} = P_{L0,i} \left[(2a_{p,i} + b_{p,i}) \left(\frac{\Delta V_i}{V_{i0}} \right) \right] (1 + k_{p,i} \Delta f_i) \quad (7)$$

Where $\Delta V_i = V_i - V_{i0}$

Neglecting the frequency dependence of load, the active power load changing at bus i then

$$\Delta P_{L,i} = P_{L0,i} \left[(2a_{p,i} + b_{p,i}) \left(\frac{\Delta V_i}{V_{i0}} \right) \right] \quad (8)$$

Then the amount active power changing of loads due to voltage fluctuation is calculated by:

$$\Delta P_L = \sum_{i=1}^{N_L} P_{L0,i} \left[(2a_{p,i} + b_{p,i}) \left(\frac{\Delta V_i}{V_{i0}} \right) \right] \quad (9)$$

where N_L is the number of loads.

On the basis of [13], the exact active power deficit, P_{def} , can be estimated by

$$P_{def} = \Delta P_g + \Delta P_L = \frac{2}{f_n} H_c \frac{df_{coi}}{dt} + \sum_{i=1}^{N_L} P_{L0,i} \left[(2a_{p,i} + b_{p,i}) \left(\frac{\Delta V_i}{V_{i0}} \right) \right] \quad (10)$$

In order to estimate the exact active power deficit, the initial rate of change of frequency at the generator terminals and the initial voltage at the load buses must be transmitted to the control center.

3. Centralized AUFLS Actions Threshold and Determination Model

Severity of a disturbance can be judged through a comparison of the measured maximum frequency deviation with a given threshold value. The study considers this value as 0.5 Hz. The calculation of the measured maximum frequency deviation is based on the system frequency response (SFR) model of the studied system.

In the analysis of system dynamic frequency deviation, the power system is commonly reduced to a simplified equivalent single-machine model ignoring the inter-machine oscillations. The simplified SFR model [16] is shown in Fig. 1. The simplified SFR model is a single-mass model. Governors and prime movers are represented by a short-term first-order model approximation.

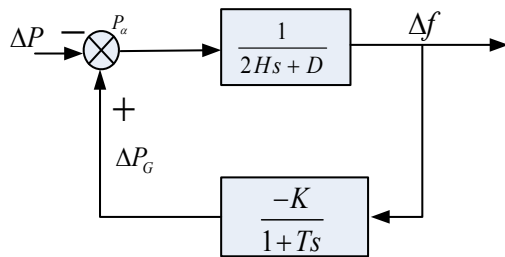

Fig. 1. SFR model transfer function block diagram

In addition, D is the system load frequency damping factor and T is the equivalent time constant of governor-prime mover. K is the equivalent gain of the governor-prime mover.

After an active power disturbance, the frequency variation in the frequency domain is then calculated as follows:

$$\Delta f(s) = \left(\frac{\omega_n^2}{D + K} \right) \left[\frac{(1 + Ts)\Delta P}{s(s^2 + 2\xi\omega_n s + \omega_n^2)} \right] \quad (11)$$

where

$$\omega_n^2 = \frac{D + K}{2HT}$$

$$\xi = \left[\frac{2H + DT}{2(D + K)} \right] \omega_n$$

By applying the inverse Laplace transform, the change of frequency as a function of time can be written:

$$\Delta f(t) = \frac{\Delta P}{D + K} \left[1 + \alpha e^{-\xi\omega_n t} \sin(\omega_r t + \phi) \right] \quad (12)$$

where

$$\alpha = \sqrt{\frac{1 - 2T\xi\omega_n + T^2\omega_n^2}{1 - \xi^2}}$$

$$\omega_r = \omega_n \sqrt{1 - \xi^2}$$

$$\phi = \phi_1 - \phi_2 = \tan^{-1} \left(\frac{\omega_r T}{1 - \xi\omega_n T} \right) - \tan^{-1} \left(\frac{\sqrt{1 - \xi^2}}{-\xi} \right)$$

By differentiating Eq. (4) with respect to the time variable of t and let the post-differentiated result be equal to zero, the result of t_{max} reveals the time when the deviation of frequency is maximum. The deviation of frequency is expressed as:

$$\Delta f_{max} = \frac{\Delta P}{D + K} \left[1 + \alpha e^{-\xi\omega_n t_{max}} \sin(\omega_r t_{max} + \phi) \right] \quad (13)$$

where

$$t_{max} = \frac{n\pi - \phi_1}{\omega_r} = \frac{1}{\omega_r} \tan^{-1} \left(\frac{\omega_r T}{\xi\omega_n T - 1} \right)$$

This equation illuminates that the maximum frequency deviation can be determined using the equivalent SFR model after estimating the imbalance power ΔP by employing the model proposed in Section 2.

4. Design of Centralized AUFLS Scheme

The task of this section is to develop a centralized AUFLS scheme using PMU.

The proposed centralized AUFLS scheme aims at achieving frequency stability through load shedding, assuming the availability of the PMU measurements. So it is very important to calculate the load shedding required for restoring the frequency to the residual level. On the assumption that the amount of spinning reserve is ΔP_{sr} , the total load needed to be shed can be evaluated as:

$$\Delta P_{LS} = \Delta P - \Delta P_{sr} \quad (14)$$

But it might also be noted that the power system losses are also a part of the system load. The system losses are changed with the variation of load flow because of load shedding and power imbalance distribution. To compensate the influence produced by the system losses and other uncertainties in system, twenty percent of the amount of spinning reserve is employed to counteract the impact of system losses in the proposed centralized AUFLS scheme. Therefore, the total load needed to be shed can be determined as:

$$\Delta P_{LS} = \Delta P - 0.8 * \Delta P_{sr} \quad (15)$$

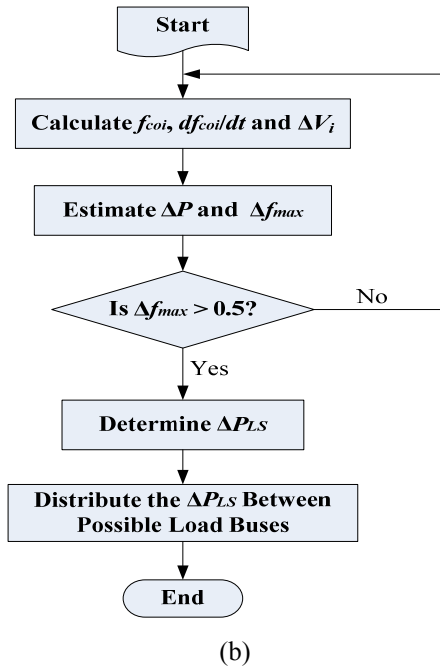
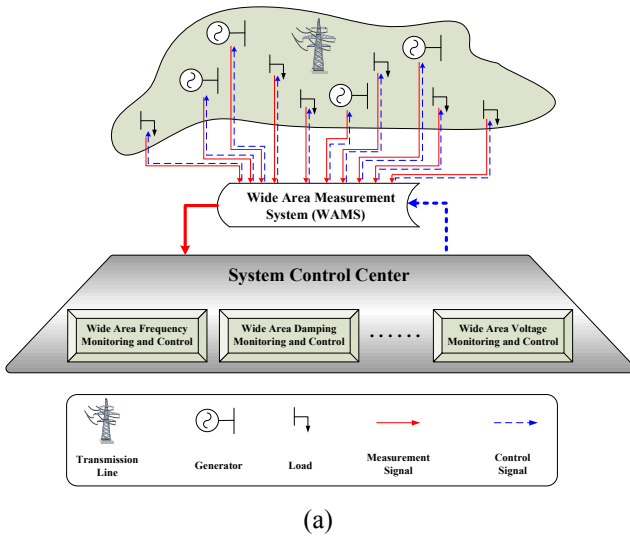

Fig. 2. Structure of the proposed AUFLS scheme: (a) Architecture of Wide Area Monitoring, Protection and Control system; (b) Flowchart of proposed centralized AUFLS scheme

The estimated magnitude of the imbalance power utilizing equation (15) is the amount of load to shed at that particular load shedding step.

Based on the above principles, a novel adaptive under frequency load shedding scheme using synchronous phase measurement unit is proposed. Four steps are included in the developed technique depicted in Fig. 1.

- Step 1.** Collecting the useful information (initial rate of change of frequency at the generator terminals and bus voltage) from the WAMS via PMU;
- Step 2.** Calculating the average frequency at the center of inertia, the rate of change of the average frequency and the voltage deviation of load buses;
- Step 3.** Estimating the magnitude of the imbalance active power and the maximum frequency deviation by employing the equation (10) and equation (13) respectively ;
- Step 4.** Comparing the maximum frequency deviation with the given threshold value. If Δf_{max} is smaller than the given threshold value, go to **Step 1**, else go to **Step 5**;
- Step 5.** If Δf_{max} exceeds the predetermined threshold value, some parts of load have to be shed. The amount of load needed to be shed is calculated using equation (10) in this step;
- Step 6.** Distributing the amount of load needed to be shed between possible load buses and sending the size of load to be shed to the frequency relay at each load bus via WAMS (In this paper, the loads to be shed are distributed between possible load buses according to the load's initial active power.).

In this paper, it is supposed that adequate PMUs were installed in power system, the frequency of the generator and bus voltage can be measured and transmitted to the control center using WAMS via PMU in time.

5. Computer Simulation Testing

The IEEE 10-generator 39-bus New England test system has been used for testing the proposed AUFLS schemes. The one line diagram of the system of the test system is shown in Fig. 3 and described in [17].

Four generator outage disturbances are applied to the simulated system as follows:

- Case 1:** Outage of generator G2 (at bus 31) with 430 MW generations;
- Case 2:** Outage of generator G3 (at bus 32) with 650 MW generations;
- Case 3:** Outage of generator G9 (at bus 38) with 830 MW generations.
- Case 4:** Outage of generator G5 (at bus 34) and G6 (at bus 35) with total 1210 MW generation.

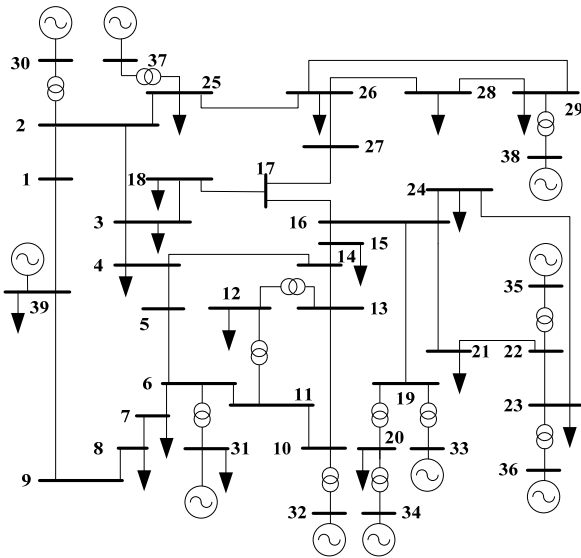

Fig. 3. One line diagram of New England test system

The magnitude of the disturbance was estimated by use of the proposed model, traditional estimation method presented in [11] respectively. The estimated results are shown in Table. 1.

It can be seen that the proposed estimation model gives a more accurate results than the traditional method since the voltage character of load is considered. The error of the proposed model is mainly caused by the uncertainties in system, such as active power losses.

In Fig. 4, the average frequency f_{coi} for four aforementioned cases in the absence of UFLS are presented. It can be seen from Fig. 4 that the frequency start declining after the disturbance occurs. By using the equation (13) and the estimated magnitude of disturbance, the maximum

Table 1. The estimated results of magnitude of disturbance

Case	Magnitude of Disturbance (MW)	Estimated Results (MW)	
		Traditional Method	Proposed Model
1	430	331.7	438.2
2	650	566.1	660.5
3	830	720.4	852.2
4	1210	1002.9	1238.5

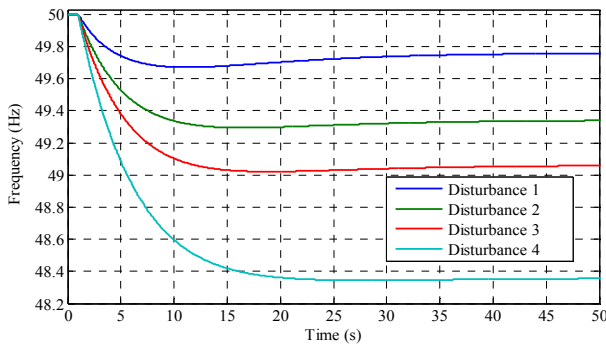

Fig. 4. Average frequency without load shedding

frequency deviation Δf_{max} under different cases are calculated and shown in Table. 2. In this paper, the studies consider the maximum frequency deviation with a given threshold value as 0.5 Hz, the security status under different are also given in Table. 2. The results in Table. 2 illustrate that, compared with the traditional estimation method, the proposed model can give a better evaluation to the security situation of the system frequency.

Based on the proposed centralized AUFLS scheme depicted in Fig. 2, the UFLS will be activated in Case 2, Case 3 and Case 4 after the disturbance.

After determining the total load needed to be shed using equation (15), single stage load shedding with set frequency 49.5 Hz, constant time delay 0.2 s, and $\Delta P_1 = \Delta P_{LS}$ is applied at load bus. Two AUFLS schemes were compared in this paper.

Scheme A: Proposed centralized AUFLS scheme;

Scheme B: Traditional UFLS scheme shown in Appendix.

For comparison reasons, the restoring effect of system frequency for Case 2, Case 3 and Case 4 are presented in Figs. 5-7. Apparently, the system frequency recovered to nominal value after disconnection of opportune amount of

Table 2. The estimated results of frequency deviation

Case	Δf_{max}	Traditional Method		Proposed Model	
		Δf_{max}	Situation	Δf_{max}	Situation
1	0.33	0.26	Security	0.31	Security
2	0.71	0.48	Security	0.69	Insecurity
3	0.98	0.72	Insecurity	1.03	Insecurity
4	1.66	1.32	Insecurity	1.47	Insecurity

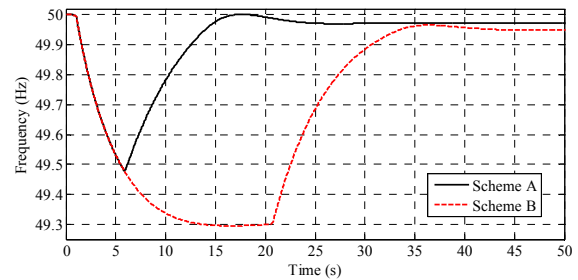

Fig. 5. Average system frequency on implementing the load shedding scheme under Case 2

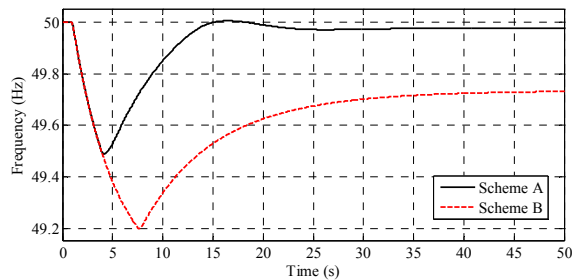

Fig. 6. Average system frequency on implementing the load shedding scheme under Case 3

Table 3. The control performance of Scheme A and Scheme B

Case	Steady Frequency (Hz)		Minimum Frequency (Hz)		Amount of Load Shed(MW)	
	Scheme A	Scheme B	Scheme A	Scheme B	Scheme A	Scheme B
2	49.9763	49.9508	49.4404	49.3522	510.5	426.8
3	49.9762	49.7326	49.4135	49.1644	713.2	426.8
4	49.9835	49.8644	49.3126	48.9569	1091.5	901.8

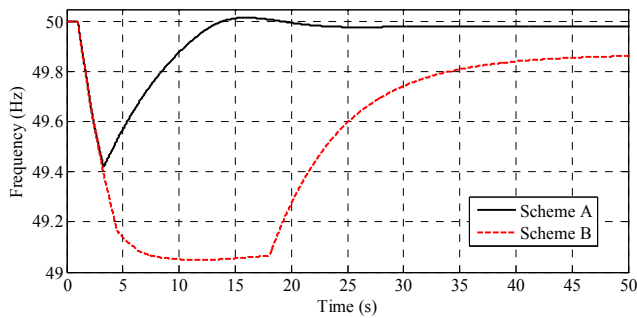

Fig. 7. Average system frequency on implementing the load shedding scheme under Case 4

load. At the same time, it can be observed that the faster frequency recovery occurred by employing the proposed centralized AUFLS scheme.

The control performance on implementing Scheme A and Scheme B are shown in Table. 3. It can be noted that each target of the proposed centralized AUFLS scheme is superior to the traditional UFLS scheme: the steady frequency and the minimum frequency. As a result of the exact estimate of the amount of load needed to be shed, no additional loads are shed while the system frequency recovered to their nominal values in a very short time period in the proposed AUFLS scheme.

Particularly, the proposed centralized AUFLS scheme has the stronger robustness to the large scale active power disturbance. The system frequency collapse can be prevented effectively after an active power impact utilizing the proposed centralized AUFLS scheme.

6. Conclusion

In this paper, a novel centralized AUFLS scheme using PMU is presented. Settings of the proposed AUFLS schemes are selected adaptively. Through the dynamic simulation carried out on a multimachine power system, the effectiveness of the proposed AUFLS scheme is investigated and discussed. It is shown that the presented model with loads contribution for estimation of the disturbance magnitude is more accurate than the conventional algorithm. The results of simulations also indicate that the AUFLS proposed in this work are capable of efficiently recovering system frequency and preserving system stability following the active power disturbances, while the amount of load to be shed by these algorithms is generally less than that of the

conventional scheme. Moreover, the proposed AUFLS scheme exhibits excellent adaptability and robustness to the disturbance.

Acknowledgements

This work was supported by National Natural Science Foundation of China (No.51177010) and Changjiang Scholars and Innovative Research Team in University (IRT1114).

References

- [1] P. Kundur, *Power system stability and control*: Englewood Cliffs, NJ: McGraw-Hill, 1994.
- [2] Tamronglak S., Horow S.H., Anatomy of power system blackouts: preventive relaying strategies, *IEEE Trans. Power Delivery*, Vol. PS-11, No. 3, pp. 708-715, June 1996.
- [3] U.S. Canada Power System Outage Task Force. *Final Report on the August 14, 2003 Blackout in the United States and Canada: causes and Recommendation*, [EB/OL]. <https://reports.energy.gov/>, 2004, 04.
- [4] Corsi S., Sabelli C., General blackout in Italy, Sunday September 28, 2003, h. 03:28:00, *IEEE Power Engineering Society General Meeting*, USA, June 2004.
- [5] Y. Halevi and D. Kottick, Optimization of load shedding system, *IEEE Trans. Energy Convers*, Vol. 8, pp. 207-213, Jun.1993.
- [6] R.M. Maliszewski, R.D. Dunlap and G.L. Wilson, Frequency Actuated Load Shedding and Restoration. Part I, Philosophy, *IEEE Trans. Power Systems*, Vol.PAS-90, pp.1452-1460, 1971.
- [7] B. Delfino, S. Massucco, A. Morini, P. Scalera, and F. Silvestro, Implementation and comparison of different under frequency load shedding schemes, *Proc. IEEE Power Engineering Society Summer meeting*, Vol.1, 2001.
- [8] Valverde G, Deyu Cai, Regulski P., Wide-Area Monitoring, Protection, and Control of Future Electric Power Networks, *Proc IEEE*, Vol. 99, No. 1, pp. 80-92, Jan. 2011.
- [9] R Sangwook Han, Byongjun Lee, Sangtae Kim, Real Time Wide Area Voltage Stability Index in the Korean

Metropolitan Area, *Journal of Electrical Engineering & Technology*, Vol. 4, No. 4, pp. 451-456, June 2009.

[10] J. De La Ree, V. Centeno, J. S. Thorp, and A. G. Phadke. Synchronized phasor measurement applications in power systems, *IEEE Trans. Smart Grid*, Vol. 1, No. 1, pp. 20-27, Jan. 2010.

[11] V. V. Terzija, Adaptive underfrequency load shedding based on the magnitude of the disturbance estimation, *IEEE Trans. on Power Systems*, Vol. 21, No. 3, pp. 20-27, Aug. 2006.

[12] H. Seyedi, M. Sanaye-Pasand, New centralized adaptive load-shedding algorithms to mitigate power system blackouts, *IET Generation, Transmission & Distribution*, Vol. 3, No. 1, pp. 99-114, June. 2008.

[13] Rudez. U., Mihalic. R., Monitoring the First Frequency Derivative to Improve Adaptive Under frequency Load-Shedding Schemes, *IEEE Trans. Power System*, Vol. 2, No. 2, pp. 839-846, May 2011.

[14] Mahdi El Arini, Optimal Dynamic Load Shedding Policy for Generation Load Imbalances Including Characteristic of Loads, *International Journal of Energy Research*, Vol. 23, No. 1, pp.79-89, Jan. 1999.

[15] Soo-Hyoung Lee, Seo-Eun Son, Sung-Moo Lee, Kalman-Filter Based Static Load Modeling of Real Power System Using K-EMS Data, *Journal of Electrical Engineering & Technology*, Vol. 7, No. 3, pp. 304-311, June 2012.

[16] P. M. Anderson, and M. Mirheydar, A Low-Order System Frequency Response Model, *IEEE Trans. on Power Systems*, Vol. 5, No. 3, pp. 720-729, Aug. 1990. http://psdyn.ece.wisc.edu/IEEE_benchmarks/.

Appendix

Traditional UFLS scheme setting

Stage	Frequency Thres hold (Hz)	Time Delay (s)	Load shed amount, %
1	49.2	0.2	7
2	49.0	0.2	7
3	48.8	0.2	7
4	48.4	0.2	7
5	49.5	15	7



D. Y. Yang He received the B.S degree in electrical engineering from Northeast Dianli University, China, in 2005 and the M.S. degree in electrical engineering from Northeast Dianli University, China, in 2009. He is pursuing the Ph.D. degree in electrical engineering at North China Electric Power University.

Currently, he is a Lecturer at Northeast Dianli University. His research interests include power system stability/control, renewable energy.



G. W. Cai He received the B.S degree and the M.S. degree in electrical engineering from Northeast Dianli University, China, in 1990 and 1993, respectively, and the Ph.D. degrees in electrical engineering from Harbin Institute of Technology, Harbin, China, in 1999. Currently, he is a Professor in

the School of Electrical Engineering, Northeast Dianli University. His research interests include power system stability/control, planning and operation.



Y. T. Jiang He received the B.S degree in electrical engineering from Northeast Dianli University, China, in 2005. He is pursuing the M.S. degree in electrical engineering at Northeast Dianli University, China. His research interests include power system dynamic stability.

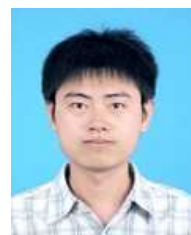

C. Liu He received the B.S degree in electrical engineering from Northeast Dianli University, China, in 2009 and the M.S. degree in electrical engineering from Northeast Dianli University, China, in 2012. He is pursuing the Ph.D. degree in electrical engineering at North China Electric Power University.

His research interests include power system stability/control, wind energy.