



Formation of Reactive Species Enhanced by H₂O₂ Addition in the Photodecomposition of N-Nitrosodimethylamine (NDMA)

Bum Gun Kwon¹, Jong-Oh Kim^{2†}, Joong-Keun Kwon^{1†}

¹Department of Bioenvironmental and Chemical Engineering, Chosun College of Science and Technology, Gwangju 501-744, Korea

²Department of Civil Engineering, Gangneung-Wonju National University, Gangneung 210-702, Korea

Abstract

This study noted that the actual mechanism of *N*-nitrosodimethylamine (NDMA) photodecomposition in the presence of H₂O₂ is missing from the previous works. This study investigated a key unknown reactive species (URS) enhanced by the addition of H₂O₂ during the photolysis of NDMA with H₂O₂, not hydroxyl radicals. In order to provide experimental evidences in support of URS formation, we have mainly used *p*-nitrosodimethylaniline, methanol, and benzoic acid as well-known probes of ·OH in this study. Both loss of PNDA and formation of hydroxybenzoic acids were dependent on NDMA concentrations during the photolysis in a constant concentration of H₂O₂. In particular, competition kinetics showed that the relative reactivity of an URS was at least identical with ·OH-like reactivity. In addition, the decay of NDMA was estimated to be about 65% by the direct UV light and about 35% by the reactive species or URS generated through the photolysis of NDMA and H₂O₂. Therefore, our data suggest that a highly oxidizing URS is formed in the photolysis of NDMA with H₂O₂, which could be peroxyxynitrite (ONOO·) as a potent oxidant by itself as well as a source of ·OH.

Keywords: H₂O₂, NDMA, Nitric oxide, Superoxide anion radical, Peroxyxynitrite

1. Introduction

N-Nitrosodimethylamine (NDMA) has been an environmentally important issue because of its potential human carcinogen and mutagen [1-5]. In particular, NDMA is classified by the United States Environmental Protection Agency (US EPA) as a B-2 carcinogen and an emerging contaminant [5]. For this reason, extensive studies have focused on the effective decontamination technologies of NDMA as well as its formation mechanism [6-10]. Recent studies have paid attention to the new routes on unintentional NDMA formation from general water treatment processes such as UV induced photochemistry [11], chlorination (or chloramination) [12, 13], and ozonation [14]. Thus, the chemical mechanism related to NDMA chemistry is one of the most significant.

Until now, various process technologies for NDMA treatment in water have been proposed. Previous studies have evidently shown that UV treatment is the most effective method due to the strong photo-sensitive NDMA [8, 10, 15-18]. Furthermore, the photo-mechanism for the decomposition of NDMA during UV-based treatment has extensively been studied [6, 8, 15, 16, 19]. However, in the UV photolysis there are concerns of nitrosamines reformation including NDMA occurrence after UV irra-

diation [8, 11, 20]. Thus, another approach to prevent the reformation of NDMA is necessary.

As an alternative method, the photodecomposition of NDMA has been performed in the presence of H₂O₂ [10]. The UV/H₂O₂ process utilizes further oxidation of NDMA by itself and/or NDMA degradation byproducts such as dimethylamine and nitrite as representative NDMA precursors via the hydroxyl radical (·OH). In this process, H₂O₂ as a source of hydroxyl radical may be quite useful for controlling NDMA reformation in post-UV treatment [8, 10, 20]. According to Sharpless and Linden [10], the addition of H₂O₂ in the photo-degradation of NDMA slightly enhanced the performance by using a low pressure Hg lamp, but economic benefit in view of practical engineering effectiveness was little or none. Since their study, however, additional study on the photodecomposition of NDMA in the presence of H₂O₂ has not been continued. Furthermore, new reactive species and a new mechanism that can be generated from the addition of H₂O₂ during the photodecomposition of NDMA have not been reported recently, to the best of our knowledge. In particular, the chemistry of reactive species generated from the direct photolysis of NDMA is of considerable significance in water purification research for those mechanistic roles and an important accompanying role of the secondary product [19]. This information is

© This is an Open Access article distributed under the terms of the Creative Commons Attribution Non-Commercial License (<http://creativecommons.org/licenses/by-nc/3.0/>) which permits unrestricted non-commercial use, distribution, and reproduction in any medium, provided the original work is properly cited.

Received November 29, 2012 Accepted January 26, 2013

[†]Corresponding Author

E-mail: jkkwon@cst.ac.kr (Joong-Keun Kwon)
Tel: +82-62-230-8521 Fax: +82-62-876-8501

E-mail: jokim@gwnu.ac.kr (Jong-Oh Kim)
Tel: +82-33-640-2420 Fax: +82-33-646-1391

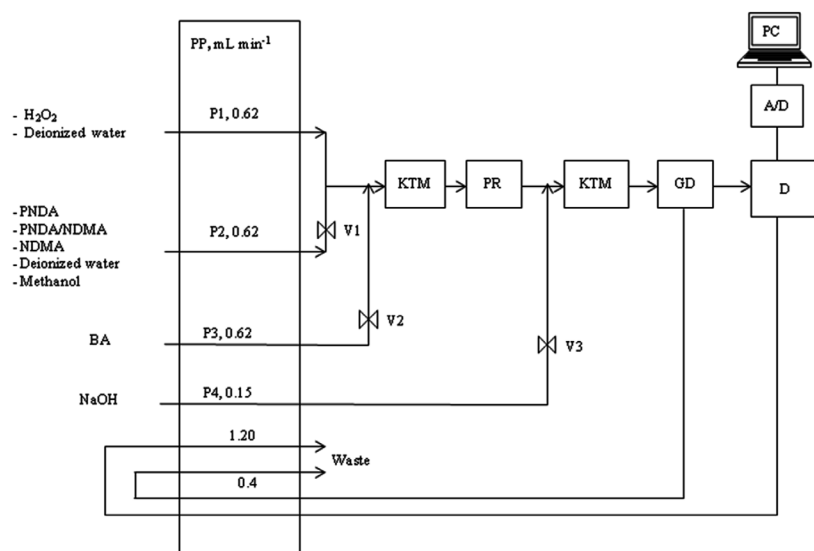

Fig. 1. Schematic diagram of the continuous flow system for the photolysis of NDMA. PP: peristaltic pump, P1, P2, P3, and P4: inlet ports, KTM: knotted tubing mixer, PR: photo-reactor, GD: glass de-bubbler, D: detector, A/D: A/D converter, PC: personal computer, V1, V2, and V3: valves.

able to contribute to the development of the kinetic computer model for the well-defined or proposed chemistry in the system that provides the best test of the actual engineering data. In this point, a critical component for the kinetic modeling is a description of the kinetics and mechanisms of the reactions for all the chemical species involved in the decay of NDMA. Thus, an understanding of the reaction mechanisms that could take place in the presence of H_2O_2 is necessary in NDMA photodecomposition.

The objective of this study is to experimentally reveal the formation of unknown reactive species (URS) and its reactivity toward NDMA photo-degradation in the presence of H_2O_2 . To investigate the formation of URS, this study employed mechanistic probing compounds which are *p*-nitrosodimethylaniline (PNDA), methanol, and benzoic acid (BA) as well-known probes of $\cdot\text{OH}$ [21, 22]. These probes and competition reactions were used to prove that a URS was probably generated from the course of the photo-degradation regarding NDMA. Thus, our study can contribute to understand the reaction mechanism of photo-chemical NDMA decomposition by means of involved URS.

2. Materials and Methods

2.1. Materials

BA, methanol, NDMA, and 30% H_2O_2 (Sigma-Aldrich, St. Louis, MO, USA) were reagent grade and were used as received from commercial supplies; water was purified with use of an aquaMAX model (Young Lin, Anyang, Korea). The PNDA (99%; Acros Organics, Geel, Belgium) was also used without further purification. To examine competition and subsequent NDMA reactions, all PNDA solutions were prepared by the addition of small amounts of borate buffer solution (pH = 8.75; LabChem, Pittsburgh, PA, USA). The concentration of H_2O_2 stock solution was determined with the KMnO_4 titration method prior to use. The working solution of H_2O_2 was prepared daily by diluting the

stock solution with water.

2.2. Experimental Apparatus and Procedures

Fig. 1 shows a schematic diagram for the experimental apparatus used in this study. The apparatus and experimental procedures employed in the present study are similar to a previous study [19] except for the port of H_2O_2 solution. All solutions were delivered with a peristaltic pump (PP; BVP-Process IP65 model; Ismatec, Glattbrugg, Switzerland) with polytetrafluoroethylene (PTFE) tubing (i.d. 0.8 mm; Cole-Parmer, Vernon Hills, IL, USA).

As shown in Fig. 1, water or the H_2O_2 solution was delivered through port 1 (P1, 0.62 mL/min). At the same time, PNDA solution alone or a mixed solution of NDMA and PNDA or methanol was delivered through port 2 (P2, 0.62 mL/min), which joined with the H_2O_2 solution or water. A 1 m long knotted tubing mixer (KTM) [23] premixed the solutions of PNDA and NDMA, PNDA only, or a mixture of NDMA/PNDA/ H_2O_2 . During a competition reaction of PNDA and NDMA on $\cdot\text{OH}$ and/or URS, valve 1 (V1) was opened, while valve 2 (V2) and valve 3 (V3) were closed. In the meantime, during the detection of *o*- and *m*-hydroxybenzoic acid isomers (OHBAs) formed from the hydroxylation of BA, V2 and V3 were opened, while V1 was closed. The typical concentrations of NDMA and PNDA were established at molar ratios ($[\text{NDMA}]_0/[\text{PNDA}]_0$) ranging from 0 to 20 based on 2.0 μM PNDA and 10 μM H_2O_2 in borate buffer solution.

Then, the premixed solutions were transferred to a quartz coil-type photo-reactor (PR), and these solutions inside the quartz coil-type PR were photolyzed by irradiation from a low pressure Hg lamp (4 W, $\lambda_{\text{max}} = 254 \text{ nm}$; Sankyo Denki G4T5, Kanagawa, Japan). The lamp was placed at the inner center of the PR. In this PR, H_2O_2 is cleaved by absorbed light, producing $\cdot\text{OH}$. After mixing in the second KTM, the photolyzed solution containing decayed NDMA and/or PNDA was delivered into a homemade glass de-bubbler (GD), which was placed prior to the detector to remove formed bubbles. The changes in the absorbance signal of PNDA and the fluorescence signal of OHBAs

were monitored for reaction times by a UV/Vis spectrophotometer (730D model; Young Lin) and by a fluorometer (474 model; Waters, Milford, MA, USA), respectively. Finally, the detected signal was transferred to a data acquisition system, which consisted of a signal amplifier, analog-to-digital converter, and personal computer.

Additionally, the induction period for photolysis (or competition reaction) was approximately 40 sec, which was based on the absorbance signal, with the total irradiation time less than approximately 3 min. To analyze NDMA, irradiated samples were repeatedly collected into sample vials at constant time intervals throughout repeated experiments.

2.3. Competition Reaction of PNDA and NDMA for a URS

A competition reaction was used to identify a URS having ·OH-like reactivity. In this process, ·OH is produced during the decomposition of H_2O_2 (reaction 1). ·OH reacts with PNDA (reaction 2, $k_2 = 1.25 \times 10^{10} \text{ M}^{-1} \text{ s}^{-1}$), H_2O_2 (reaction 3, $k_3 = 2.7 \times 10^7 \text{ M}^{-1} \text{ s}^{-1}$), and NDMA (reaction 4, $k_4 = 3.3\text{--}4.3 \times 10^8 \text{ M}^{-1} \text{ s}^{-1}$) [21, 22, 24, 25]. In particular, this study considered a URS generated through reaction 5 during NDMA photolysis in the absence of H_2O_2 , based on the result of Kwon et al. [19]. Here, $\text{HO}_2\cdot$ and UV do not decompose PNDA [21, 26]. The concentration of added H_2O_2 was always constant with $10 \mu\text{M}$, which is reasonable to assume that the concentration of ·OH generated from the photolysis of H_2O_2 is constant in various concentrations of PNDA and NDMA, respectively.

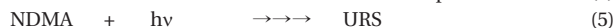

The competition kinetic model for the NDMA and PNDA in this study is Equation 1 (E1) listed below:

$$\frac{S_0}{S} = 1 + \frac{k_4[\text{NDMA}]_0}{k_2[\text{PNDA}]_0} \quad (\text{E1})$$

where S_0 represents the loss rate of PNDA in the absence of NDMA, and S represents the loss rate of PNDA in the presence of NDMA; $[\text{PNDA}]_0$ and $[\text{NDMA}]_0$ in E1 are the initial concentrations. Control experiments consisted of the same mixture and irradiation conditions without the H_2O_2 . Since k_2 is well-known (reaction 2), the plot of the S_0/S vs. $[\text{NDMA}]_0/[\text{PNDA}]_0$ should be a straight line with an intercept of 1 and a slope of k_4/k_2 .

2.4. Analyses

NDMA was analyzed by high performance liquid chromatography (2690 Model and PDA 996; Waters) with a $\mu\text{Bondapak C18}$ ($3.9 \times 300 \text{ mm}$; Waters) employing UV detection at 228 nm. The eluent consisted of water:phosphoric acid = 99:1 (volume %) with a flow rate of 0.8 mL/min [19]. The detection limits of this method was approximately $0.1 \mu\text{M}$, based on the signal-to-noise ratio (SNR) = 3.

All absorbance measurements of PNDA were adjusted with borate buffer solution because the maximum extinction coefficient, $32,282 \text{ M}^{-1} \text{ cm}^{-1}$, of PNDA at 446 nm was observed at pH 8.75 [26]. The concentration of PNDA was determined in a con-

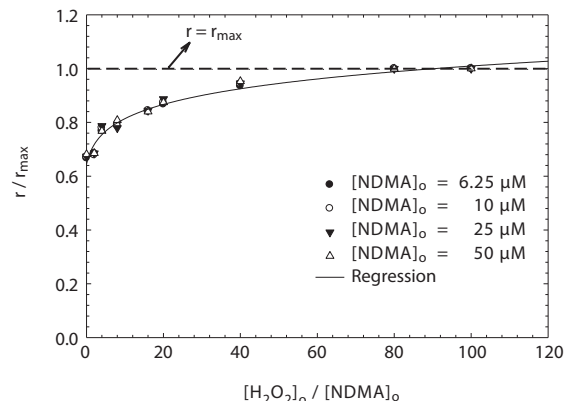

Fig. 2. Normalized initial rates (r/r_{max}) of N-nitrosodimethylamine (NDMA) photodecomposition plotted against $[\text{H}_2\text{O}_2]_0/[\text{NDMA}]_0$. Experimental condition: pH, 8.75; and wavelength, 254 nm.

tinuous flow by using a UV/Vis spectrophotometer (730D; Young Lin).

To identify the formation possibility of URS and/or ·OH driven from NDMA photodecomposition with H_2O_2 , OHBAs as main products of BA trapped ·OH were determined with a fluorescence detector (474 model; Waters) at 400 nm (emission), which was excited by 320 nm (excitation) [23]. A 0.5 N NaOH solution (pH ≥ 11) was used to enhance fluorescence intensity, as shown in Fig. 1.

The dissolved oxygen (DO) was measured with a DO meter (SensorLink PCM800; Thermo Scientific Orion, Waltham, MA, USA).

3. Results and Discussion

3.1. NDMA Photodecomposition by Reactive Species in the Presence of H_2O_2

To account for the dependences of reactive species (or URS) and the UV photolysis on NDMA decay in the presence of H_2O_2 , a series of experiments were carried out over a range of initial NDMA concentrations (6.25–50 μM) at pH 8.75. In each experiment, the relative importance on H_2O_2 effect during NDMA photolysis was investigated, based on the initial rate ($r = -d[\text{NDMA}]/dt$) of NDMA photo-decay over $[\text{H}_2\text{O}_2]_0/[\text{NDMA}]_0$. To the best of our knowledge, this attempt has not been previously reported in the literature. Here, the maximum initial rate (r_{max}) during NDMA photo-decay was observed at a molar ratio of $[\text{H}_2\text{O}_2]_0/[\text{NDMA}]_0 \approx 80\text{--}100$, as shown in Fig. 2. In addition, the concentration of H_2O_2 was varied in a wide range depending on the molar ratio of $[\text{H}_2\text{O}_2]_0/[\text{NDMA}]_0$, based on a given NDMA concentration. Thus, the normalized initial rate ratio (r/r_{max}) of NDMA decay on the effect of H_2O_2 can be determined.

Fig. 2 shows r/r_{max} as a function of $[\text{H}_2\text{O}_2]_0/[\text{NDMA}]_0$ in a given NDMA concentration at pH 8.75. As shown in Fig. 2, r/r_{max} was gradually increased with increasing molar ratio of $[\text{H}_2\text{O}_2]_0/[\text{NDMA}]_0$, and then it was constant at the molar ratio of $[\text{H}_2\text{O}_2]_0/[\text{NDMA}]_0 = 80\text{--}100$. In particular, the ratio of r/r_{max} without H_2O_2 at a given NDMA concentration was 0.65, and its ratio at a molar ratio of $[\text{H}_2\text{O}_2]_0/[\text{NDMA}]_0 = 80\text{--}100$ was approximately 1, as shown in Fig. 2. This result suggests that the ratio of r/r_{max}

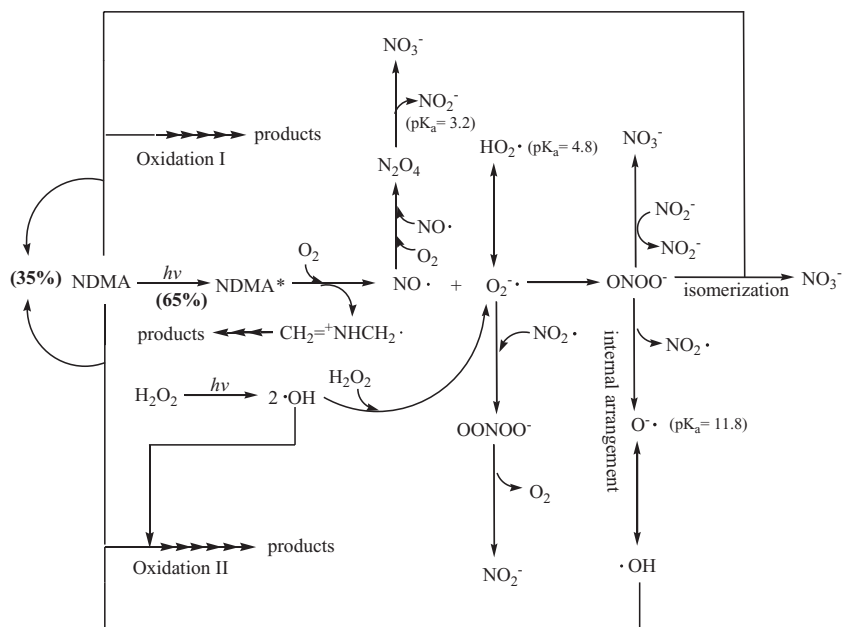

Fig. 3. Mechanism of the photolytic pathways for formation of URS during NDMA photolysis in the presence of H_2O_2 . Note that the percentage in parentheses shows the contribution of the reactive species (or URS) and UV photolysis, respectively, on NDMA degradation. NDMA: N-nitrosodimethylamine, URS: unknown reactive species.

is independent of the initial NDMA concentration, but this ratio at above 0.65 is dependent on the initial H_2O_2 concentration added. In other words, as described in Fig. 3 approximately 65% of NDMA decay was accomplished by the direct photodecomposition of NDMA by UV light, whereas about 35% referred to the effect of reactive species (i.e., $\cdot\text{OH}$) and/or URS generated through the photolysis of H_2O_2 (reactions 1 and 5) and a subsequent unknown reaction(s). This result seems to be similar to that observed by Sharpless and Linden [10]. According to their study, the addition of 2.94 mM H_2O_2 in the photo-degradation of NDMA lead to approximately a 30% increase in performance by the low pressure Hg lamp, compared with treatment using UV alone in the absence of H_2O_2 . Even though the initial rate of NDMA photo-decay was mostly explained by UV photolysis, the addition of H_2O_2 considerably enhanced direct photolysis of NDMA. This result can be explained by considering the photochemically generated $\cdot\text{OH}$ and/or URS. Thus, the effect of H_2O_2 can be quantitatively explained by the reactive species including URS.

3.2. Competition Reaction between Probes and NDMA for URS

In this study, a competition reaction was used to identify the reactivity of an URS or reactive species. Reactive species including URS can be produced through NDMA photo-decay in the presence of H_2O_2 , in which a hydroxyl radical (reaction 1) and URS (reaction 5) are able to competitively react with PNDA and NDMA [19]. Hence, the competition reaction between NDMA and PNDA as a well-known representative probe for $\cdot\text{OH}$ on an URS was investigated in this study. In this experiment, the concentrations of H_2O_2 and PNDA were always constant with 10 and 2 μM , respectively, at pH 8.75. As a result, NDMA concentrations

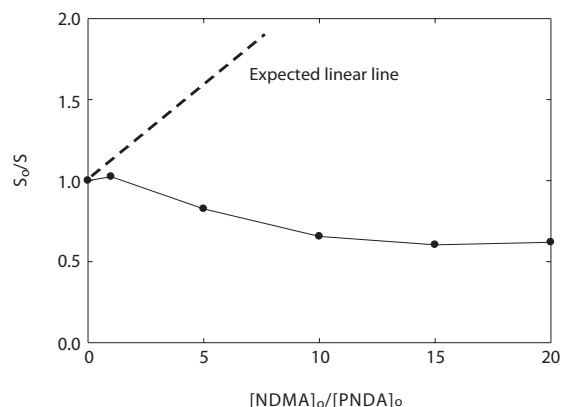

Fig. 4. S_0/S plotted against $[\text{NDMA}]_0/[\text{PNDA}]_0$. Experimental conditions: pH, 8.75; $[\text{H}_2\text{O}_2]_0 = 10 \mu\text{M}$, $[\text{PNDA}]_0 = 2 \mu\text{M}$; and wavelength, 254 nm. Note that the dashed line is a linear line generally expected in the competition kinetics. NDMA: N-nitrosodimethylamine, PNDA: p-nitrosodimethylaniline.

were varied in a wide range from 0 to 40 μM depending on the molar ratio of $[\text{NDMA}]_0/[\text{PNDA}]_0$.

Fig. 4 presents S_0/S as a function of $[\text{NDMA}]_0/[\text{PNDA}]_0$. As shown in Fig. 4, S_0/S was slightly increased into a molar ratio = 1 of $[\text{NDMA}]_0/[\text{PNDA}]_0$, and thereafter, these values were rapidly decreased with an increasing ratio of $[\text{NDMA}]_0/[\text{PNDA}]_0$. At the molar ratio = 20 of $[\text{NDMA}]_0/[\text{PNDA}]_0$, S_0/S was 0.62. This result shows that the S of URS generated in the presence of NDMA is much higher with approximately 1.61 times than S_0 in the absence of NDMA. In other words, the decomposition rate of PNDA was dependent on the initial concentration of NDMA, which

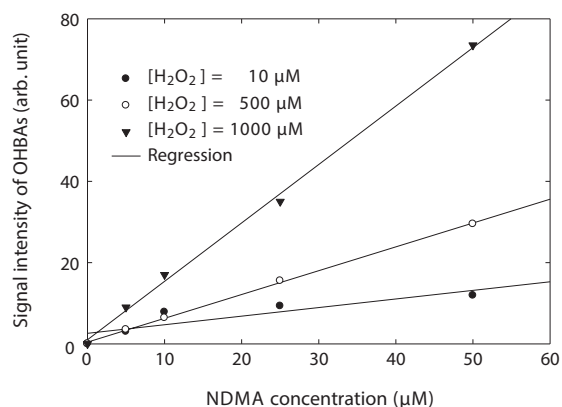

Fig. 5. Fluorescence signal intensity of OHBAs from BA depending on initial NDMA concentration added in the photolysis of NDMA. Experimental conditions: pH, 8.75; $[BA]_0 = 1$ mM; and wavelength, 254 nm. Note that the signal intensity of OHBAs (arbitrary unit), which means the fluorescence signal intensity produced from URS during the photo-degradation of NDMA, subtracts the fluorescence signal intensity of H_2O_2 alone from the total fluorescence signal intensity in the presence of NDMA and H_2O_2 . NDMA: N-nitrosodimethylamine, OHBA: hydroxybenzoic acid, BA: benzoic acid, URS: unknown reactive species.

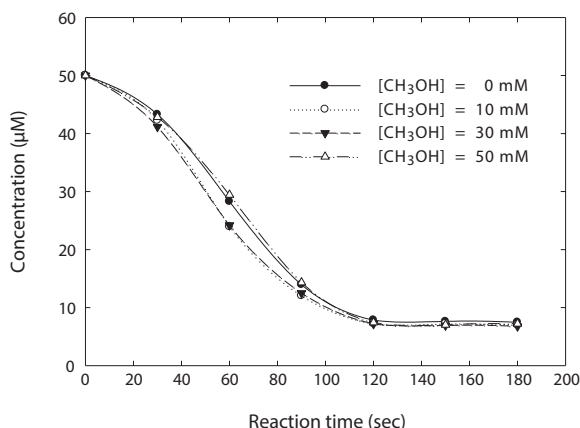

Fig. 6. N-nitrosodimethylamine (NDMA) photodecomposition depending on methanol added in the photolysis of NDMA. Experimental conditions: pH, 8.75; $[H_2O_2]_0 = 10$ μ M; and wavelength, 254 nm.

means a marked increasing PNDA decay rate with increasing initial concentrations of NDMA. This result was unexpected in the competition kinetics under the same condition with 10 μ M H_2O_2 , even though NDMA was strongly photo-labile.

In the general competition kinetics, S in the presence of NDMA should be smaller than S_0 in the absence of NDMA, and thus S_0/S vs. $[NDMA]_0/[PNDA]_0$ generally produces a linear slope of the rate constant ratio (k_4/k_2) in E1 [27, 28], as is depicted by the bold dashed line shown in Fig. 4. In our experiment, owing to H_2O_2 concentration fixed with 10 μ M, the concentration of $\cdot OH$ generated from reaction 1 could be the same in all cases. Furthermore, PNDA did not react with $HO_2\cdot/O_2\cdot^-$ and the nitric oxide radical ($NO\cdot$) generated from NDMA photo-decay, and UV

photolysis of PNDA was not observed [21, 26]. Thus, further enhanced decay of PNDA could stem from URS having an $\cdot OH$ -like reactivity during NDMA photo-decay in the presence of H_2O_2 .

To further examine a URS having $\cdot OH$ -like reactivity during the photolysis of NDMA, a series of experiments were performed in the presence of 1 mM BA as a $\cdot OH$ probe and in a range of initial H_2O_2 concentrations (10–1,000 μ M). BA is a well-known $\cdot OH$ probe ($k = 4.3 \times 10^9$ $M^{-1} s^{-1}$) that is able to scavenge $\cdot OH$, producing OHBAs [23]. In this experiment, the signal intensity of OHBAs (arbitrary unit) subtracted the fluorescent signal intensity of H_2O_2 alone from the total fluorescence signal intensity in the presence of NDMA and H_2O_2 .

Fig. 5 demonstrates the formation of OHBAs in the photo-decay of NDMA. As shown in Fig. 5, OHBAs produced through reactions between $\cdot OH$ and BA were linearly increased with increasing initial concentration of NDMA at a given concentration of H_2O_2 . This indicates that URS having $\cdot OH$ -like reactivity and/or additional $\cdot OH$ could be produced by an unknown pathway during the photochemical decay of NDMA, influencing intermediates or other products. Thus, a URS having $\cdot OH$ -like reactivity can influence the photolysis of NDMA.

To further examine URS formed during the photolysis of NDMA, methanol was used as an alternative probe for $\cdot OH$, which is able to scavenge $\cdot OH$ [29–31]. A series of experiments were performed in the presence of H_2O_2 and at pH 8.75. At this time, the concentration of methanol added was varied in excess ranging from 0 to 50 mM, compared to the concentration of NDMA.

As shown in Fig. 6, an excess of methanol (50 mM) did not interfere with the photo-decay of NDMA, but, rather, methanol of 30 mM or less improved the photo-degradation of NDMA slightly. Even though $\cdot OH$ would be produced in this experiment, most of $\cdot OH$ is able to be scavenged by an excess of methanol, producing a hydroperoxyl radical ($HO_2\cdot$) and HCHO as final products (reactions 6–8) [29]. This result suggests that a URS formed during the photodecomposition of NDMA reacts with NDMA. As a result, the slightly enhanced decomposition of NDMA could result from a URS formed by the photolytic behaviors of NDMA in the presence of methanol.



3.3. Possible Mechanism of URS formation in the Photo-decomposition of NDMA

As shown in Figs. 2–5, a URS generated from the course of the photo-degradation of NDMA in the presence of H_2O_2 would be a strong reactive species having $\cdot OH$ -like reactivity. To the best of our knowledge, one of the plausible explanations on the URS is additional $\cdot OH$ and/or peroxyxynitrite ($ONOO\cdot$), as described in Fig. 3.

Excited NDMA under UV light irradiation releases $NO\cdot$ by photo-elimination from the homolytic cleavage of N-NO bonds (reactions 9–10), and by photo-hydrolysis from the heterolytic cleavage of N-NO bonds (reaction 11) [6, 16, 17]. Here, NDMA is photolyzed to dimethylamine ($CH_3 = NHCH_3$) and the aminium radical ($CH_2 = \cdot NHCH_3$) which have very weak reactivity [6]. In the initial step, $NO\cdot$ and the superoxide anion radical ($O_2\cdot^-$) in an excess of oxygen ($DO = 0.39$ mM) could undergo a rapid combination reaction to yield the powerful oxidant $ONOO\cdot$ (reaction

12). The generation of $\text{NO}\cdot$ and the concomitant formation of $\text{O}_2\cdot^-$ were confirmed by Chow [6] and by Lee et al. [16], respectively. Thus, URS as a new reactive species can be related to the formation of $\text{ONOO}\cdot$.



In the meantime, $\text{HO}_2\cdot/\text{O}_2\cdot^-$ formed from reaction 3 and reaction 11 is dependent upon the acid-base equilibrium (reaction 14) [32]. Considering our experimental conditions ($\text{pH} = 8.75$), self-disproportionation by reactions 15–16 ($k_{15} = 8.3 \times 10^5 \text{ M}^{-1} \text{ s}^{-1}$; $k_{16} = 9.76 \times 10^7 \text{ M}^{-1} \text{ s}^{-1}$) will not be occurred. Furthermore, reaction 17 at high pH is negligible due to its small rate constant ($k_{17} < 0.3 \text{ M}^{-1} \text{ s}^{-1}$) [32]. Under our experimental conditions, the disproportionation of $\text{HO}_2\cdot/\text{O}_2\cdot^-$ is too slow to compete with reaction 12. Therefore, the steady-state concentrations of $\text{NO}\cdot$ and $\text{O}_2\cdot^-$ are sufficiently high that $\text{ONOO}\cdot$ can be produced by reaction 12 ($k_{12} = 4.3 \times 10^9 \text{ M}^{-1} \text{ s}^{-1}$) [33].

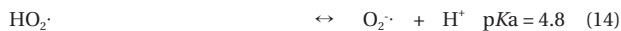

Recent studies have revealed that the decomposition of $\text{ONOO}\cdot$ can generate $\text{NO}_2\cdot$ and $\cdot\text{OH}$ with a 30% yield as well as $\text{NO}_3\cdot$ with a 70% yield [34], even though the reactivity of $\text{ONOO}\cdot$ and its decay pathways have been in dispute [34–39]. In addition, according to Koppenol et al. [36], $\text{ONOO}\cdot$ can be a strongly oxidizing compound by itself. Hence, the reactivity of $\text{ONOO}\cdot$ is closely intertwined with that of $\cdot\text{OH}$, and appears to have significant rivaling to that of $\cdot\text{OH}$.

As shown in Figs. 3–5, at the alkaline pH solution, both loss of PNDA and formation of OHBAs providing experimental evidences in support of URS and/or $\cdot\text{OH}$ formation were dependent on NDMA concentrations during the photolysis with the constant concentration of a given H_2O_2 . In particular, as shown in Fig. 6, an excess of methanol ($\leq 30 \text{ mM}$) improved the photodecomposition of NDMA slightly. These results suggest that a highly reactive oxidizing species can be $\text{ONOO}\cdot$ by itself or $\cdot\text{OH}$. Therefore, our data suggest that, presumably, a highly oxidizing URS is formed in the photolysis of NDMA in the presence of H_2O_2 , which is $\text{ONOO}\cdot$ as a potent oxidant, as described in Fig. 3.

4. Conclusions

Careful work in this study led to the discovery that a URS generated from NDMA photolysis with a constant concentration of H_2O_2 added was enhanced with increasing NDMA. The detailed study was performed with competition kinetics and probes for URS. Both loss of PNDA and formation of OHBAs were dependent on concentrations of NDMA during the photolysis of NDMA with $10 \mu\text{M}$ H_2O_2 added. In particular, the competition kinetic method demonstrated that the relative reactivity of a URS was identical with $\cdot\text{OH}$ -like reactivity. These results suggest that a highly oxidizing URS is $\text{ONOO}\cdot$ as a potent oxidant by itself as well as a source of $\cdot\text{OH}$.

Acknowledgement

This was supported by the National Research Foundation (NRF) grant funded by the Korea government (MEST, 2012-0005227).

References

1. Liteplo RG, Meek ME, Windle W; International Programme on Chemical Safety. N-Nitrosodimethylamine. Geneva: World Health Organization; 2002.
2. Charrois JW, Arend MW, Froese KL, Hrudey SE. Detecting N-nitrosamines in drinking water at nanogram per liter levels using ammonia positive chemical ionization. *Environ. Sci. Technol.* 2004;38:4835-4841.
3. Plumlee MH, Reinhard M. Photochemical attenuation of N-nitrosodimethylamine (NDMA) and other nitrosamines in surface water. *Environ. Sci. Technol.* 2007;41:6170-6176.
4. Plumlee MH, Lopez-Mesas M, Heidlberger A, Ishida KP, Reinhard M. N-nitrosodimethylamine (NDMA) removal by reverse osmosis and UV treatment and analysis via LC-MS/MS. *Water Res.* 2008;42:347-355.
5. U.S. Environmental Protection Agency. Technical fact sheet N-nitroso-dimethylamine (NDMA). Washington: EPA; 2012. No. EPA-505-F-11-006.
6. Chow YL. Nitrosamine photochemistry: reactions of aminium radicals. *Acc. Chem. Res.* 1973;6:354-360.
7. Mirvish SS. Formation of N-nitroso compounds: chemistry, kinetics, and in vivo occurrence. *Toxicol. Appl. Pharmacol.* 1975;31:325-351.
8. Stefan M, Bolton JR. UV direct photolysis of N-nitrosodimethylamine (NDMA): kinetic and product study. *Helv. Chim. Acta* 2002;85:1416-1426.
9. Mitch WA, Sedlak DL. Formation of N-nitrosodimethylamine (NDMA) from dimethylamine during chlorination. *Environ. Sci. Technol.* 2002;36:588-595.
10. Sharpless CM, Linden KG. Experimental and model comparisons of low- and medium-pressure Hg lamps for the direct and H_2O_2 assisted UV photodegradation of N-nitrosodimethylamine in simulated drinking water. *Environ. Sci. Technol.* 2003;37:1933-1940.
11. Lee C, Yoon J. UV-A induced photochemical formation of N-nitrosodimethylamine (NDMA) in the presence of nitrite and dimethylamine. *J. Photochem. Photobiol. A Chem.* 2007;189:128-134.
12. Chen Z, Valentine RL. The influence of the pre-oxidation of natural organic matter on the formation of N-nitrosodimethylamine (NDMA). *Environ. Sci. Technol.* 2008;42:5062-5067.
13. Mitch WA, Schreiber IM. Degradation of tertiary alkylamines during chlorination/chloramination: implications for formation of aldehydes, nitriles, halonitroalkanes, and nitrosamines. *Environ. Sci. Technol.* 2008;42:4811-4817.
14. Schmidt CK, Brauch HJ. N,N-dimethylsulfamide as precursor for N-nitrosodimethylamine (NDMA) formation upon ozonation and its fate during drinking water treatment. *Environ. Sci. Technol.* 2008;42:6340-6346.
15. Lee J, Choi W, Yoon J. Photocatalytic degradation of N-nitroso dimethylamine: mechanism, product distribution, and TiO_2 surface modification. *Environ. Sci. Technol.* 2005;39:6800-6807.

16. Lee C, Choi W, Kim YG, Yoon J. UV photolytic mechanism of N-nitrosodimethylamine in water: dual pathways to methylamine versus dimethylamine. *Environ. Sci. Technol.* 2005;39:2101-2106.
17. Lee C, Choi W, Yoon J. UV photolytic mechanism of N-nitrosodimethylamine in water: roles of dissolved oxygen and solution pH. *Environ. Sci. Technol.* 2005;39:9702-9709.
18. Lee C, Yoon J, von Gunten U. Oxidative degradation of N-nitrosodimethylamine by conventional ozonation and the advanced oxidation process ozone/hydrogen peroxide. *Water Res.* 2007;41:581-590.
19. Kwon BG, Kim JO, Namkung KC. The formation of reactive species having hydroxyl radical-like reactivity from UV photolysis of N-nitrosodimethylamine (NDMA): kinetics and mechanism. *Sci. Total Environ.* 2012;437:237-244.
20. Landsman NA, Swancutt KL, Bradford CN, Cox CR, Kiddle JJ, Mezyk SP. Free radical chemistry of advanced oxidation process removal of nitrosamines in water. *Environ. Sci. Technol.* 2007;41:5818-5823.
21. Kraljic I, Trumbore CN. p-Nitrosodimethylaniline as an OH radical scavenger in radiation chemistry. *J. Am. Chem. Soc.* 1965;87:2547-2550.
22. Buxton GV, Greenstock CL, Helman WP, Ross AB. Critical review of rate constants for reactions of hydrated electrons, hydrogen atoms and hydroxyl radicals (OH/O^\cdot) in aqueous solution. *J. Phys. Chem. Ref. Data* 1988;17:513-886.
23. Kwon BG, Lee JH. A kinetic method for $\text{HO}_2^\cdot/\text{O}_2^\cdot$ determination in advanced oxidation processes. *Anal. Chem.* 2004;76:6359-6364.
24. Wink DA, Nims RW, Desrosiers MF, Ford PC, Keefer LK. A kinetic investigation of intermediates formed during the Fenton reagent mediated degradation of N-nitrosodimethylamine: evidence for an oxidative pathway not involving hydroxyl radical. *Chem. Res. Toxicol.* 1991;4:510-512.
25. Mezyk SP, Cooper WJ, Madden KP, Bartels DM. Free radical destruction of N-nitrosodimethylamine in water. *Environ. Sci. Technol.* 2004;38:3161-3167.
26. Kwon BG, Ryu S, Yoon J. Determination of hydroxyl radical rate constants in a continuous flow system using competition kinetics. *J. Ind. Eng. Chem.* 2009;15:809-812.
27. Kochany J, Bolton JR. Mechanism of photodegradation of aqueous organic pollutants. 2. Measurement of the primary rate constants for reaction of hydroxyl radicals with benzene and some halobenzenes using an EPR spin-trapping method following the photolysis of hydrogen peroxide. *Environ. Sci. Technol.* 1992;26:262-265.
28. Mabury SA, Crosby DG. Pesticide reactivity toward hydroxyl and its relationship to field persistence. *J. Agric. Food Chem.* 1996;44:1920-1924.
29. Asmus KD, Moeckel H, Henglein A. Pulse radiolysis study of the site of hydroxyl radical attack on aliphatic alcohols in aqueous solution. *J. Phys. Chem.* 1973;77:1218-1221.
30. Hess WP, Tully FP. Hydrogen-atom abstraction from methanol by hydroxyl radical. *J. Phys. Chem.* 1989;93:1944-1947.
31. Zhou X, Mopper K. Determination of photochemically produced hydroxyl radicals in seawater and freshwater. *Mar. Chem.* 1990;30:71-88.
32. Bielski BH, Cabelli DE, Arudi RL, Ross AB. Reactivity of $\text{HO}_2/\text{O}_2^\cdot$ radicals in aqueous solution. *J. Phys. Chem. Ref. Data* 1985;14:1041-1100.
33. Goldstein S, Czapski G. The reaction of NO^\cdot with O_2^\cdot and HO_2^\cdot : a pulse radiolysis study. *Free Radic. Biol. Med.* 1995;19:505-510.
34. Goldstein S, Lind J, Merenyi G. Chemistry of peroxyxynitrites as compared to peroxyxynitrates. *Chem. Rev.* 2005;105:2457-2470.
35. Beckman JS, Beckman TW, Chen J, Marshall PA, Freeman BA. Apparent hydroxyl radical production by peroxyxynitrite: implications for endothelial injury from nitric oxide and superoxide. *Proc. Natl. Acad. Sci. U S A* 1990;87:1620-1624.
36. Koppenol WH, Moreno JJ, Pryor WA, Ischiropoulos H, Beckman JS. Peroxyxynitrite, a cloaked oxidant formed by nitric oxide and superoxide. *Chem. Res. Toxicol.* 1992;5:834-842.
37. White CR, Brock TA, Chang LY, et al. Superoxide and peroxyxynitrite in atherosclerosis. *Proc. Natl. Acad. Sci. U S A* 1994;91:1044-1048.
38. Gerasimov OV, Lyman SV. The yield of hydroxyl radical from the decomposition of peroxyxynitrous acid. *Inorg. Chem.* 1999;38:4317-4321.
39. Coddington JW, Hurst JK, Lyman SV. Hydroxyl radical formation during peroxyxynitrous acid decomposition. *J. Am. Chem. Soc.* 1999;121:2438-2443.