

# A DVR Control for Compensating Unbalanced Voltage Dips of a DFIG System using Zero Sequence Components

Quach Ngoc Think\* · Ji-Han Ko · Dong-Wan Kim · Eel-Hwan Kim\*\*

## Abstract

The dynamic voltage restorer (DVR) is an effective protection device for wind turbine generators based on doubly-fed induction generator (DFIG) that is operated under unbalanced voltage dip conditions. The compensating voltages of the DVR depend on the voltage dips and on the influence of the zero sequence component. The zero sequence component results in high insulation costs and asymmetry in terminal voltages. This paper proposes the use of a proportional-resonant controller in stationary reference frames for controlling zero sequence components in the DVR to protect the DFIG during unbalanced voltage dips. To enhance the proposed control method, a comparison is carried out between two cases: with and without using the control of a zero sequence component. Simulation results are presented to verify the effectiveness of the proposed control method by using the Psim simulation program.

Key Words : Dynamic Voltage Restorer (DVR), Doubly-Fed Induction Generator (DFIG), Unbalanced Voltage Dip, Zero Sequence Component

## 1. Introduction

Currently, wind farms are contributing a large amount of power to the power grid system. The disconnect of these wind farms due to faulty events

will therefore cause power quality problems to the grid. A wind turbine based on a DFIG is a device sensitive to grid disturbances, especially to voltage dips [1]. As well, new grid codes require wind turbines based on DFIG to remain connected during the occurrence of unbalanced voltage dips [2]. There is a great deal of research regarding many methods for protecting the DFIG from unbalanced voltage dips that found in the literature. Some methods are carried by changing the structure control of the grid side converter and rotor side converter [3-4]. Other methods include the addition of an external protection device to the DFIG system. In [5], a

---

\* Main author : Department of Electrical Engineering, Jeju National University  
\*\* Corresponding author : Professor with the Department of Electrical Engineering, Jeju National University  
Tel : 064-754-3678, Fax : 064-756-5281  
E-mail : ehkim@jejunu.ac.kr  
Date of submit : 2012. 11. 7.  
First assessment : 2012. 11. 23.  
Completion of assessment : 2013. 1. 7.

crowbar system is connected to a rotor circuit in the case of rotor overcurrents or dc-link overvoltages, but the machine draws a high short circuit current when the crowbar is activated. The DVR is an effective external protection device for sensitive loads, such as DFIGs, when operated under unbalanced voltage dip conditions [6–8]. Little research has analyzed the restoration of the positive sequence and compensation for negative sequence components, while the effects of a zero sequence component in compensating voltages of the DVR have also been ignored. In DFIG systems connected to the grid, if  $Y_0/\Delta$  step-up transformers are used, there are no zero sequence components on the DFIG side. However, currently the  $Y_0/Y_0$  step-up transformers are used increasingly in distribution systems. Thus, the zero sequence component will appear on the DFIG side during faults. The zero sequence component results in high insulation costs and asymmetry in terminal voltages. In [9], a method is presented for mitigating zero sequence effects in the DVR by providing a circulation path within the DVR for zero sequence current. A generating mechanism of a self zero sequence component in a system with different neutral point grounded modes is presented in [10]. This paper proposes a method for controlling zero sequence components in the DVR to protect DFIG during unbalanced voltage dips. In this control method, three phases of compensating voltages are controlled as three single phases separately in stationary reference frames. Hence, proportional–resonant (PR) controllers are applied. To enhance the proposed control method, a comparison is also carried out between two cases: with and without using the control of a zero sequence component. With this control method, the DVR will compensate fully the unbalanced voltage dips, while the DFIG can operate normally during faults.

## 2. The Operations of DFIG

The DFIG system used in this paper is shown in Fig. 1. It consists of basic components such as the turbine, a gear box, a DFIG, and a back-to-back voltage source converter system with a dc-link. The DFIG system is linked to the grid via a transformer the coils of which are arranged in the form of  $Y_0/Y_0$ .

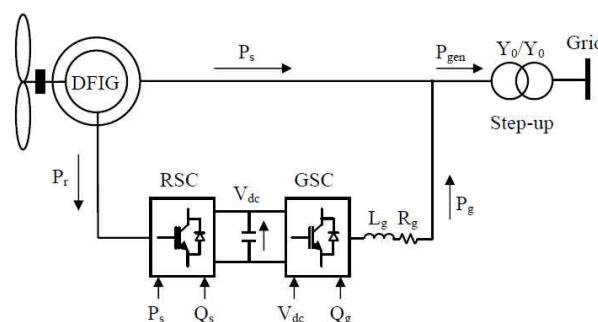

Fig. 1. Schematic diagram of a doubly-fed induction generator based on wind generation systems

### 2.1. RSC control

The aims of the rotor side converter (RSC) control are to control the stator active and reactive powers independently. By using the stator flux oriented vector control strategy and neglecting stator resistance, the stator active and reactive powers can be expressed as [11]

$$P_s = -\frac{3}{2} \frac{L_m}{L_s} V_{sq} I_{rq} \quad (1)$$

$$Q_s = \frac{3}{2} \frac{V_{sq}}{L_s} (\psi_{sd} - L_m I_{rd}) \quad (2)$$

where  $P_s$  and  $Q_s$  are stator active and reactive powers.  $L_m$  and  $L_s$  are the magnetizing and stator inductances.  $V_{sd}$  and  $V_{sq}$  are dq components of stator voltages.  $I_{rd}$  and  $I_{rq}$  are dq components of

rotor currents.  $\psi_{sd}$  is the d component of stator flux.

From (1) and (2), the control of stator active power is achieved by controlling the rotor current q component orthogonal to the stator flux, while the stator reactive power control is achieved by controlling the rotor current d component aligned to the stator flux.

### 2.2 GSC control

The aims of the grid side converter (GSC) control are to maintain the dc-link capacitor voltage constant and to ensure a converter operation with the unity power factor. The current equation that flows through the inductor can be written as follows

$$\frac{dI_g}{dt} = \frac{V_g - R_g I_g}{L_g} \tag{3}$$

where  $V_g$ ,  $I_g$ ,  $R_g$ , and  $L_g$  are voltage, current, resistance and inductance at the grid side, respectively.

The dc-link voltage can be expressed by

$$C \frac{dV_{dc}}{dt} = I_r - I_g \tag{4}$$

where  $V_{dc}$  is dc-link voltage, C is dc-link capacitor, and  $I_r$  is rotor current.

The cascade vector control structure is carried out with an inner current control loop and outer dc-link voltage control loop combining with a reactive power control as in (3) and (4).

### 3. The Proposed Control Method

The proposed diagram for connecting the DVR as protection for the DFIG system is shown in Fig. 2.

As mentioned before, the use of a star-star step-up transformer in the distribution system will introduce a zero sequence component in supply voltages during unbalanced voltage dip faults ( $V_{s0} \neq 0$ ). This zero sequence component will propagate into terminal voltages if it is not eliminated fully in the DVR. By applying Kirchhoff's voltage law, the zero sequence component of terminal voltages can be expressed by

$$V_{t0} = V_{s0} + V_o \neq 0 \tag{5}$$

where  $V_{s0}$ ,  $V_o$ , and  $V_{t0}$  are zero sequence components of supply voltages, compensating voltages, and terminal voltages, respectively.

In order to suppress the zero sequence component in terminal voltages ( $V_{t0}=0$ ), the DVR must generate a zero sequence component that will be equal in magnitude and opposite in direction to the zero sequence component present in the supply voltages. This means that

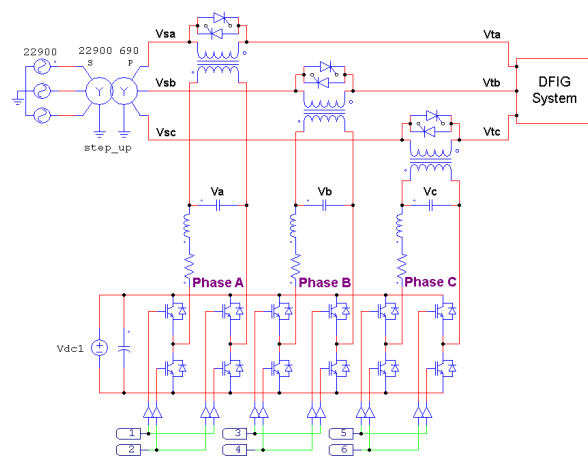

Fig. 2. Schematic diagram of a DFIG system with DVR.  $V_{sa}$ ,  $V_{sb}$ , and  $V_{sc}$  are three-phase supply voltages.  $V_a$ ,  $V_b$ , and  $V_c$  are three-phase compensating voltages.  $V_{ta}$ ,  $V_{tb}$ , and  $V_{tc}$  are three-phase terminal voltages of DFIG system

$$V_o = -V_{so} \tag{6}$$

The zero sequence component of compensating voltages is

$$V_o = \frac{1}{3}(V_a + V_b + V_c) \tag{7}$$

where (7) shows that the zero sequence component depends on the compensating voltages  $V_a$ ,  $V_b$ , and  $V_c$ .

### 3.1 DVR without a controlling zero sequence component

A control diagram of a DVR consisting only of the control of positive and negative sequence components are mentioned (Fig. 3). The supply voltages, prefault voltages, and compensating voltages are analyzed into positive and negative sequence components. Two reference frames, namely the synchronous reference frame and negative synchronous reference frame, and four proportional-integral controllers are used. As described before, the supply voltages will contain three components (positive, negative, and zero sequence components) during unbalanced voltage dip faults. With this control method, only the positive and negative sequence components are compensated, therefore the faulty voltages cannot restore fully to its original value.

### 3.2 DVR with a controlling zero sequence component

In the proposed control method, the compensating voltages are controlled in a stationary frame by using PR controllers as developed in [12]. Three-phase voltages are not, however, transformed

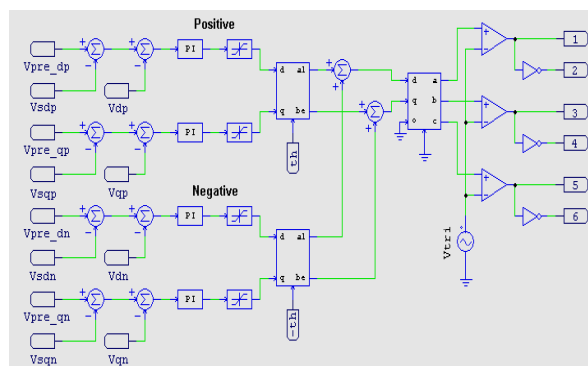

Fig. 3. The control method without controlling zero sequence component.  $V_{pre\_dp}$ ,  $V_{pre\_qp}$ ,  $V_{pre\_dn}$ ,  $V_{pre\_qn}$ ,  $V_{sdp}$ ,  $V_{sqp}$ ,  $V_{sdn}$ ,  $V_{sqn}$ ,  $V_{dp}$ ,  $V_{qp}$ ,  $V_{dn}$ , and  $V_{qn}$  are the positive and negative sequence components of prefault voltages, supply voltages, and terminal voltages. Subscripts p, n are the positive and negative sequence components in a synchronous reference frame.  $\theta$  is the synchronous angle of voltage

into  $\alpha\beta$ -frame, instead being controlled directly in the abc-frame. The three-phase voltages are controlled independently of each other (Fig. 4). Thus, the sum of the three-phase compensating voltages cannot be zero.

$$V_a + V_b + V_c \neq 0 \tag{8}$$

Considering from (6), (7), and (8), this means that the zero sequence component can be eliminated from the restored voltages with the proposed control method.

The differences between this control method and existing control methods can be seen in Fig. 4. First, the voltages are measured and controlled directly in a three-phase frame. Transformation to a synchronous reference frame is not necessary. Therefore, it is simpler than the general control methods [9-10] where the voltages are measured, transformed, and controlled in a synchronous reference frame. Second, the proportional-resonant controllers in the stationary reference frame are

used instead of the proportional–integral controllers in a synchronous reference frame.

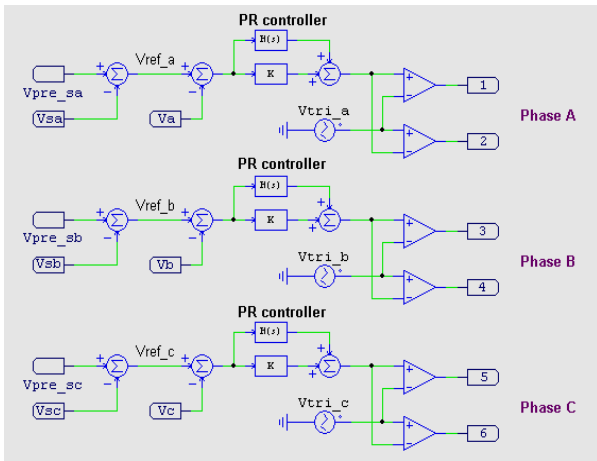

**Fig. 4.** The proposed control method of DVR for controlling zero sequence component.  $V_{pre\_sa}$ ,  $V_{pre\_sb}$ , and  $V_{pre\_sc}$  are three-phase pre-fault voltages.  $V_{ref\_a}$ ,  $V_{ref\_b}$ , and  $V_{ref\_c}$  are three-phase reference compensating voltages. The transfer function of PR:  $G_{PR} = K_p + K_i \cdot \omega_c \cdot s / (s^2 + 2 \cdot \omega_c \cdot s + \omega_e^2)$

### 4. Simulation Results

Simulation results have been performed by using a Psim simulation program for a 2 MW DFIG wind turbine system and a DVR as analyzed in Sections 2 and 3. The DFIG parameters are given in Table I. The stator active power is controlled at 2 MW. The switching frequency of the DVR is 5 kHz. The injection transformer turn ratio is 1:1. The unbalanced grid voltage dips appear at 2 s and are removed at 2.15 s. The operation of the DVR to compensate for the unbalanced voltage dips, which contain a zero sequence component, without and with the controlling zero sequence component are presented in Fig. 5 and Fig. 6, respectively.

The unbalanced voltage dips and zero sequence components are shown in Fig. 5 (a), (d) and Fig. 6 (a), (d). With the control of positive and negative

sequence components, the terminal voltages cannot be fully restored (Fig. 5 (c)). Consequently, these voltages are unbalanced, and its zero sequence component is almost the same as the zero sequence component of the supply voltages as seen in Fig. 5

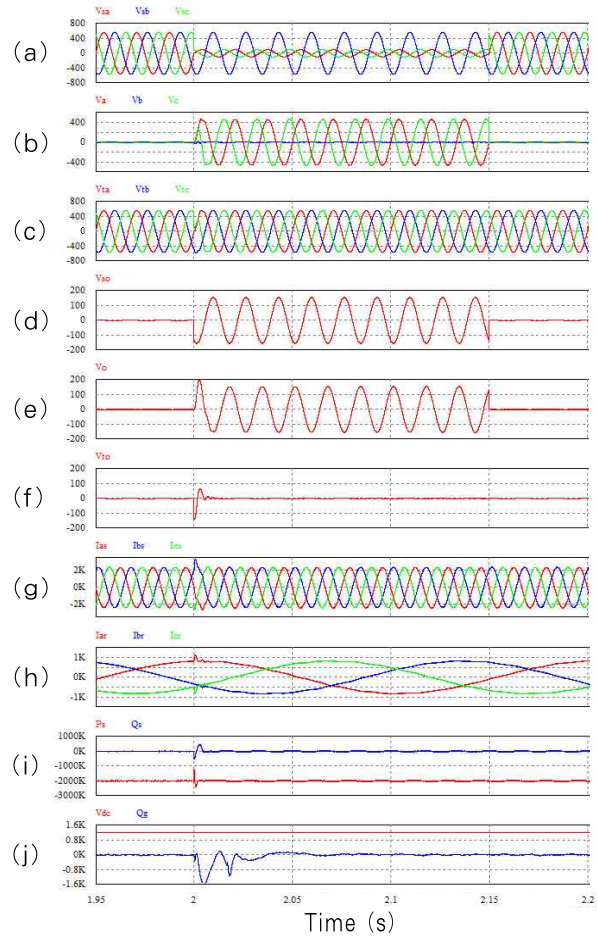

**Fig. 5.** The simulation results without a controlling zero sequence component in a DVR as compensation for unbalanced voltage dips of a DFIG. (a) supply voltages; (b) compensating voltages of DVR; (c) terminal voltages of DFIG system; (d), (e) and (f) zero sequence components of supply voltages, compensating voltages, and terminal voltages; (g) stator currents; (h) rotor currents; (i) active and reactive powers of DFIG; (j) dc-link voltage and reactive power from grid side converter

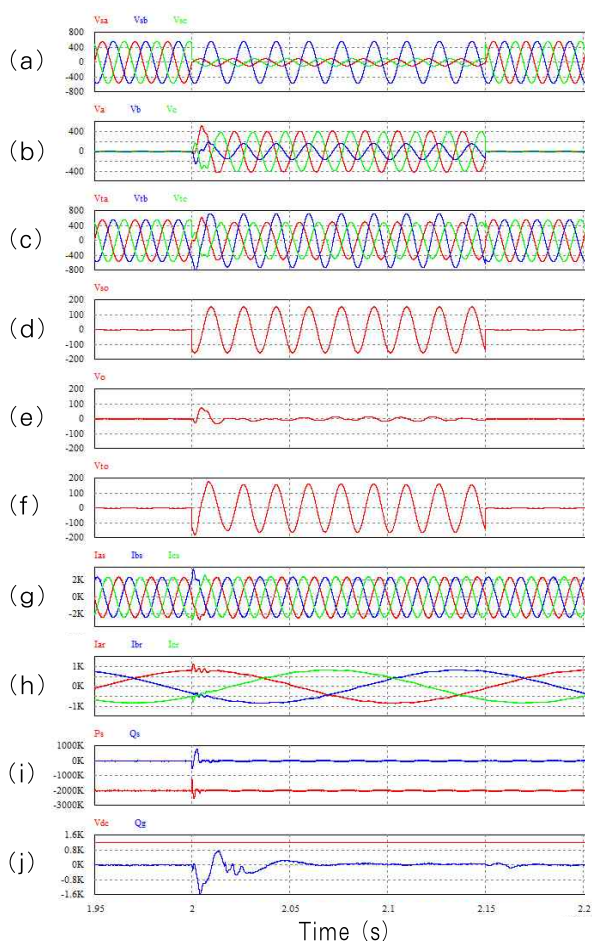

**Fig. 6.** The simulation results with a controlling zero sequence component in a DVR as compensation for unbalanced voltage dips of a DFIG. (a) supply voltages; (b) compensating voltages of DVR; (c) terminal voltages of DFIG system; (d), (e) and (f) zero sequence components of supply voltages, compensating voltages, and terminal voltages; (g) stator currents; (h) rotor currents; (i) active and reactive powers of DFIG; (j) dc-link voltage and reactive power from grid side converter

(d), (f). However, by applying the proposed control method, the DVR has the ability to compensate for unbalanced voltage dips containing the zero sequence component as depicted in Fig. 6 (b), (e). As a result, the terminal voltages are restored (Fig.

6 (c)) and the almost zero sequence component is eliminated (Fig. 6 (f)). With DVR protection in both cases, the DFIG can operate normally during unbalanced voltage dips as shown in Fig. 5 (g)–(j) and Fig. 6 (g)–(j) because the zero sequence component does not effect DFIG operations. However, zero sequence components will cause such problems as electrical insulation and asymmetric voltages. This lead to an increase in high insulation costs in a DFIG system. Therefore, the control of zero sequence components is truly necessary.

## 5. Conclusion

The application of a DVR to compensate for unbalanced voltage dips of a DFIG system has been investigated. The compensating voltages of a DVR depend on the voltage dips and on the influence of the zero sequence component. With the proposed control method in the stationary frame, the DVR can compensate fully for a zero sequence component during unbalanced voltage dip faults. Consequently, the restored voltages are almost balanced and the DFIG can operate normally during faults. The simulation results confirm the effectiveness of the proposed control method.

**Table 1.** SIMULATION PARAMETER OF 2MW DFIG

Rated power	2 MW
Stator voltage (phase-to-phase, rms)	690V
Stator voltage frequency	60Hz
Stator resistance	1.1616mΩ
Rotor resistance	1.307mΩ
Stator leakage inductance	0.05835mH
Rotor leakage inductance	0.06286mH
Magnetizing inductance	2.496mH

### Acknowledgement

This work was supported by the Human Resources Development of the Korea Institute of Energy Technology Evaluation and Planning (KETEP) grant funded by the Korea Government Ministry of the Knowledge Economy. (NO.20094020200020)

### References

- [1] J. Lopez, E. Gubia, P. Sanchis, X. Roboam, and L. Marroyo, "Wind Turbines Based on Doubly Fed Induction Generator Under Asymmetrical Voltage Dips," *IEEE Trans. Energy Convers.*, Vol. 23, No. 1, pp. 321-330, Mar. 2008.
- [2] M. Tsili and S. Papathanassiou, "A review of grid code technical requirements for wind farms," *IET. Renewable Power Generat.*, Vol. 3, No. 3, pp. 308-332, Sep. 2009.
- [3] L. Xu and Y. Wang, "Dynamic Modeling and Control of DFIG-Based Wind Turbine under Unbalanced Network Conditions," *IEEE Trans. Power Syst.*, Vol. 22, No. 1, pp. 314-323, Feb. 2007.
- [4] L. Xu, "Coordinated control of DFIG's rotor and grid side converters during network unbalance," *IEEE Trans. Power Electron.*, Vol. 23, No. 3, pp. 1041-1049, May 2008.
- [5] J. Morren and S.W.H. de Haan, "Ridethrough of wind turbines with doubly-fed induction generator during a voltage dip," *IEEE Trans. Energy Convers.*, Vol. 20, No. 2, pp. 435-441, Jun. 2005.
- [6] D. Ramirez, S. Martinez, C.A. Platero, F. Blazquez, and R.M. de Castro, "Low-Voltage Ride-Through Capability for Wind Generators Based on Dynamic Voltage Restorers," *IEEE Trans. Energy Convers.*, Vol. 26, No. 1, pp. 195-203, Mar. 2011.
- [7] H. Awad, J. Svensson, and M. Bollen, "Mitigation of Unbalanced Voltage Dips Using Static Series Compensator," *IEEE Trans. Power Electron.*, Vol. 19, No. 3, pp. 837-846, May 2004.
- [8] C. Wessels and F. Fuchs, "High Voltage Ride Through with Facts for DFIG Based Wind Turbines," in *Proc. 13th Eur. Conf. Power Electron. Appl. (EPE)*, pp. 1-10, Sep. 2009.
- [9] D. M. Vilathgamuwa and H. M. Wijekoon, "Mitigating Zero Sequence Effects in Dynamic Voltage Restorers," *IEEE Specialists Conf. Power Electron. (PESC 2007)*, pp. 3079-3085, June 2007.
- [10] Zhongdong Yin and Lixia Zhou, "Self Zero Sequence Component Control of Dynamic Voltage Restorer in Systems with Different Neutral Point Grounded Modes," in *The 7th International Conf. Power Engineering (IPEC 2005)*, pp. 1-4, Nov. 29 2005-Dec. 2 2005.
- [11] R. Pena, J.C. Clare, and G.M. Asher, "Doubly fed induction generator using back-to-back PWM converters and its application to variable-speed wind-energy generation," *IEE Proc.*, Vol. 143, No. 3, pp. 231-241, May 1996.
- [12] R. Teodorescu, F. Blaabjerg, M. Liserre, and P. C. Loh,

"Proportional-resonant controllers and filters for grid-connected voltage-source converters," *IEE Proc. Electr. Power Appl.*, Vol. 153, No. 5, pp. 750-762, Sep. 2006.

### 저자소개



#### Quach Ngoc Thinh

Mr. Thinh received a Bachelor's degree in Electrical Engineering from Can Tho University, Vietnam, in 2007 and a Master's degree in Electrical Engineering from Jeju National University, Jeju, S. Korea, in 2012. He is currently a PhD candidate at the Department of Electrical Engineering, Jeju National University, Jeju, S. Korea. His research interests include wind energy systems, HVDC systems, and power system stability.

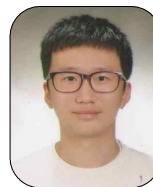

#### Ji-Han Ko

Mr. Ko received a Bachelor's degree in Electrical Engineering from Jeju National University, Jeju, Korea, in 2012. He is currently a Master's candidate in the Department of the Multidisciplinary Graduate School Program for Wind Energy, Jeju National University, Jeju, S. Korea. His research interests include wind energy systems and power electronics.



#### Dong-Wan Kim

Mr. Kim received a Bachelor's degree in Electrical Engineering from Jeju National University, Jeju, Korea, in 2012. He is currently a Master's candidate in the Department of the Multidisciplinary Graduate School Program for Wind Energy, Jeju National University, Jeju, S. Korea. His research interests include wind energy systems and power electronics.



#### Eel-Hwan Kim

Dr. Kim received B.S., M.S., and Ph.D. degrees in Electrical Engineering from Chung-Ang University, Seoul, Korea, in 1985, 1987, and 1991, respectively. He was a Visiting Scholar with the Ohio State University, Columbus, OH, The United States, in 1995, and with the University of Washington, Seattle, WA, The United States, in 2004. He is currently a Professor with the Department of Electrical Engineering, Jeju National University, Jeju, Korea. His current research activities include power electronics and control, which includes drive systems, renewable energy control applications, and power quality.