

# A Novel Data Transmission Scheme for ATSC Terrestrial DTV Systems

Sung Ik Park, Heung Mook Kim, Wangrok Oh, and Jeongchang Kim

**In Advanced Television Systems Committee (ATSC) terrestrial digital television (DTV) systems, additional very low-rate data can be transmitted by modulating the amplitude and polarity of the transmitter identification (TxID) signal. Although the additional data transmission scheme offers reliable transmission and has a very large coverage area, it has a limitation on the data rate. In this paper, we propose a novel additional data transmission scheme based on the TxID sequences of the ATSC DTV system and Walsh modulation. The proposed scheme not only increases the data rate significantly, but also offers a virtually identical coverage area compared to a conventional scheme.**

**Keywords: ATSC DTV, Kasami sequence, transmitter identification, Walsh sequence.**

## I. Introduction

In single-frequency networks (SFNs) for the Advanced Television Systems Committee (ATSC) terrestrial digital television (DTV) systems, interference is inevitably induced by the multiple transmitters and/or repeaters using the same frequency, and thus the performance of DTV systems is degraded [1], [2]. This problem can be solved by adjusting the transmit power and timing of each transmitter and/or repeater after detecting channel profiles in the SFNs and estimating the individual reception power from each transmitter and/or repeater [3], [4]. To facilitate the interference manipulation, the ATSC Standard A/110 introduces transmitter identification (TxID) signals with very low power, which are embedded in the DTV signal to be transmitted from each transmitter and repeater [1].

On the other hand, in [5], [6], a very low-rate data transmission scheme that provides robustness and extremely large coverage was developed by modulating the amplitude and polarity of the TxID signal. However, the achievable data rate of the scheme in [5], [6] is at most up to a few hundred bits per second (bps), for example, 210 bps with 4-level pulse amplitude modulation (4-PAM).

In this paper, we propose a novel data transmission scheme using TxID and Walsh sequences in ATSC DTV systems. The proposed scheme transmits data bits using a Walsh sequence and its polarity. The proposed scheme significantly enhances the data rate compared to the conventional scheme. Also, the performance of the proposed scheme is analyzed and evaluated.

The remainder of this paper is organized as follows. In section II, system models and conventional data transmission schemes are briefly presented. In section III, the proposed scheme is described, and in section IV, a performance analysis is theoretically performed. In section V, numerical results are

---

Manuscript received May 19, 2011; revised Sept. 9, 2011; accepted Oct. 19, 2011.

This research was supported by the Korea Communications Commission (KCC), Rep. of Korea, under the support program supervised by the Korea Communications Agency (KCA) (Development of Wake-up Emergency Alert Broadcast System Using DTV).

Sung Ik Park (phone: +82 42 860 6648, [psi76@etri.re.kr](mailto:psi76@etri.re.kr)) and Heung Mook Kim ([hmkim@etri.re.kr](mailto:hmkim@etri.re.kr)) are with the Broadcasting and Telecommunications Convergence Research Laboratory, ETRI, Daejeon, Rep. of Korea.

Wangrok Oh ([kingrock@cnu.ac.kr](mailto:kingrock@cnu.ac.kr)) is with the Department of Electrical and Computer Engineering, Chungnam National University, Daejeon, Rep. of Korea.

Jeongchang Kim (corresponding author, [jchkim@hhu.ac.kr](mailto:jchkim@hhu.ac.kr)) is with the Department of Electronics and Communications Engineering, Korea Maritime University, Busan, Rep. of Korea.

<http://dx.doi.org/10.4218/etrij.12.0111.0311>

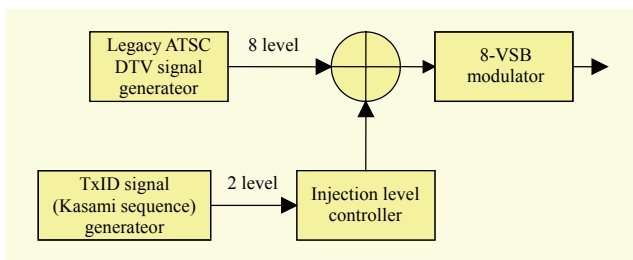

Fig. 1. ATSC DTV transmitter with TxID.

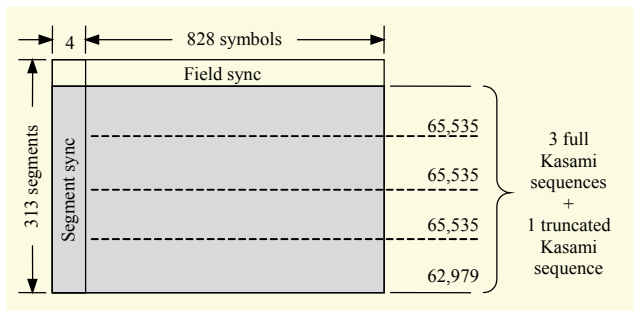

Fig. 2. Injection scheme of Kasami sequences.

presented, and, finally, conclusions are drawn in section VI.

## II. System Models

### 1. TxID Signal Transmission

The ATSC Standard A/110 introduces a particular form of pseudo-random noise sequences, referred to as Kasami sequences, to identify multiple transmitters and/or repeaters in SFNs [1]. The Kasami sequences are binary sequences of length  $2^n - 1$ , where  $n$  is an even integer. They comprise a large set, denoted as  $K_L$ , and a small set, denoted as  $K_S$ . Note that the large set includes all of the sequences in the small set. In addition, they have good auto-correlation and cross-correlation properties with large family sizes.

The Kasami sequence defined in the ATSC Standard A/110 is a large set with  $n=16$ , and the generator polynomial is given as  $G(x) = G_1(x) \cdot G_2(x) \cdot G_3(x)$ , where

$$G_1(x) = x^{16} + x^{12} + x^3 + x + 1$$

$$G_2(x) = x^{16} + x^{12} + x^{11} + x^9 + x^8 + x^4 + x^3 + x^2 + 1,$$

$$G_3(x) = x^8 + x^7 + x^6 + x^3 + x^2 + x + 1.$$

As shown in Fig. 1, the Kasami sequence is modulated with two levels and scaled by a predetermined injection level before being added to the ATSC DTV signal. The total number of symbols in one field excluding a field sync segment is 259,584 (312 segments  $\times$  832 symbols/segment) [7], and the length of the Kasami sequence is 65,535 ( $2^{16} - 1$ ) [1]. As shown in Fig. 2,

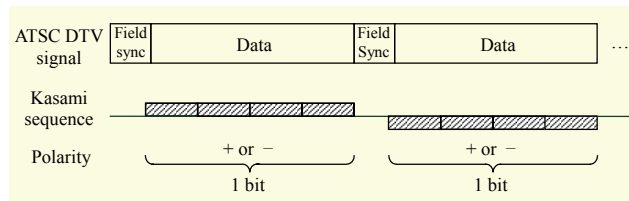

Fig. 3. 40-bps mode.

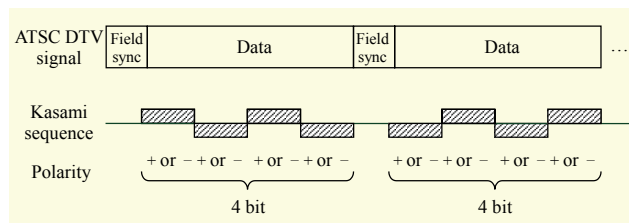

Fig. 4. 160-bps mode.

the ATSC Standard A/110 provides a scheme for embedding a Kasami sequence where the sequence of length 65,535 is repeated three times and the truncated sequence of length 62,979 is appended.

### 2. Conventional Scheme for Additional Data Transmission

To transmit additional data, each TxID sequence is modulated with input data. In [5], to transmit additional data using TxID signals, a polarity modulation was employed. Figures 3 and 4 show additional data transmission schemes of [5] with 40 bps and 160 bps, respectively. For the 40 bps mode, one polarity data bit is transmitted during one field duration. Note that the spreading factor of 40-bps mode is 259,584, and thus after despreading, the SNR gain of  $10 \log_{10} 259,584 = 54.1428$  dB is obtained. For 160-bps mode, on the other hand, one polarity data bit is transmitted during one (truncated) Kasami sequence, and thus 4 bits are transmitted during one field duration. Note that the spreading factor of 160-bps mode is 65,535 or 62,979. Hence, the spreading factor of 160-bps mode is decreased and the loss of the SNR gain is approximately 6 dB compared to the 40-bps mode.

In this manner, we can simply increase the data rate with a further reduced spreading factor. However, this straightforward scheme is very inefficient in the usage of the given bandwidth. Note that the simple decrease in the spreading factor inevitably induces the loss of the signal-to-noise ratio (SNR) gain and thus the noise margin of the system is severely degraded.

At the receiver, after multiplying the received signal by the reference Kasami sequence, the polarity is detected, and thus the transmitted data bits can be recovered from the resulting polarity [6].

Let us consider a single transmitter. The transmitted signal

can thus be written as

$$s(n) = d(n) + \rho \sum_{j=1}^4 v_j \{P_j(n)x(n)\}, \quad (1)$$

where  $d(n)$ ,  $\rho$ , and  $x(n)$  denote the DTV signal, injection level, and TxID sequence, respectively. Also,  $P_j(n)$  is given as

$$P_j(n) = \begin{cases} 1, & (j-1)L_j + 1 \leq n \leq jL_j, \quad j = 1, \dots, 4, \\ 0, & \text{otherwise,} \end{cases} \quad (2)$$

and  $v_j \in \{-1, +1\}$ ,  $j = 1, \dots, 4$ , denotes the polarity data corresponding to the  $j$ -th Kasami sequence where  $L_j$  denotes the length of the  $j$ -th Kasami sequence.

After passing through the channel  $h$ , the received signal  $r(n)$  is given as

$$r(n) = s(n) \otimes h + w(n), \quad (3)$$

where  $w(n)$  is the noise at the receiver and  $\otimes$  denotes the convolution operation.

To demodulate the polarity data  $v_j$ , the received signal  $r(n)$  is correlated with the Kasami sequence  $x(n)$ . The cross-correlation between  $r(n)$  and  $x(n)$  corresponding to the  $j$ -th Kasami sequence is then written as

$$z_j = \sum_{n=L_j(j-1)+1}^{jL_j} r(n)x(n), \quad j = 1, \dots, 4. \quad (4)$$

By slicing  $z_j$ , we can obtain the polarity data  $\hat{v}_j$  as

$$\hat{v}_j = \text{sgn}\{z_j\}, \quad (5)$$

where  $\text{sgn}\{a\}$  denotes the sign of  $a$ .

### III. Proposed Scheme for Additional Data Transmission

In this section, we propose a novel additional data transmission scheme for ATSC DTV systems. Figures 5 and 6 show the block diagram and principle of the proposed data transmission scheme, respectively. As shown in Fig. 5, first,  $(1+\log_2 M)$  data bits,  $b_0, b_1, \dots, b_M$ , are grouped and form a symbol using the serial-to-parallel converter, where  $M$  denotes the number of Walsh sequences used. The first bit,  $b_0$ , is the polarity data, and the group of the remaining  $M$  bits is one-to-one mapped to one of the  $M$  Walsh sequences of length  $M$ ,  $\mathbf{w}_1, \mathbf{w}_2, \dots, \mathbf{w}_M$ , where  $\mathbf{w}_i = \{w_{i1}, w_{i2}, \dots, w_{iM}\}$ ,  $w_{im} \in \{-1, +1\}$ ,  $m=1, 2, \dots, M$ , denotes the  $i$ -th Walsh sequence of length  $M$ . The mapped Walsh sequence is then spread by the Kasami sequence of length  $L_j$  used for TxID. In other words, as shown in Fig. 6, each element  $w_{im}$  of the mapped Walsh sequence is sequentially spread by  $L_j/M$  chips of the Kasami sequence. The first  $L_j/M$  chips of the Kasami sequence are multiplied by the first element  $w_{i1}$  of the Walsh sequence. In this manner, the last  $L_j/M$  chips of the Kasami sequence are multiplied by the last element  $w_{iM}$  of the Walsh sequence. Finally, the resulting sequence is injected to the legacy ATSC DTV data with an

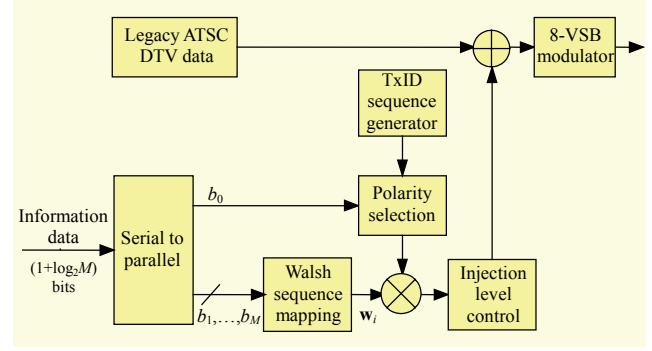

Fig. 5. Block diagram of proposed scheme.

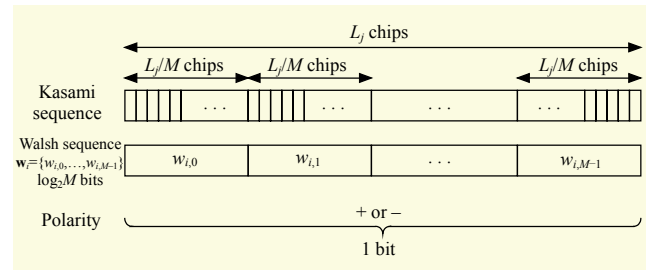

Fig. 6. Principle of proposed scheme.

appropriate injection level.

Again, let us consider the single transmitter case. The transmitted signal can then be written as

$$s(n) = d(n) + \rho \sum_{j=1}^4 \sum_{m=1}^M v_j \{P_j(n)x(n)\} \{c_{j,m}W_m(n)\}, \quad (6)$$

where

$$W_m(n) = \begin{cases} 1, & (m-1)\frac{L_j}{M} + 1 \leq n \leq m\frac{L_j}{M}, \quad m = 1, \dots, M, \\ 0, & \text{otherwise,} \end{cases} \quad (7)$$

and  $\mathbf{c}_j = \{c_{j,1}, \dots, c_{j,M}\}$  denotes the Walsh sequence to be transmitted during the  $j$ -th Kasami sequence duration in a field where  $\mathbf{c}_j \in \{\mathbf{w}_1, \dots, \mathbf{w}_M\}$ . After passing through channel  $h$ , the received signal  $r(n)$  is given by  $r(n) = s(n) \otimes h + w(n)$ .

At the receiver, the received signal is first multiplied by the reference Kasami sequence as

$$\begin{aligned} z(n) &= r(n) \cdot x(n) \\ &= \{s(n) \otimes h + w(n)\} \cdot x(n) \\ &= s(n) \otimes h \cdot x(n) + w(n) \cdot x(n) \\ &= \rho \sum_{j=1}^4 \sum_{m=1}^M v_j \{P_j(n)x(n)\} \{c_{j,m}W_m(n)\} \otimes h \cdot x(n) \\ &\quad + d(n) \otimes h \cdot x(n) + w(n) \cdot x(n) \\ &= \rho v_j c_{j,m} \otimes h + d(n) \otimes h \cdot x(n) + w(n) \cdot x(n) \\ &= z_{j,m}(n), \end{aligned} \quad (8)$$

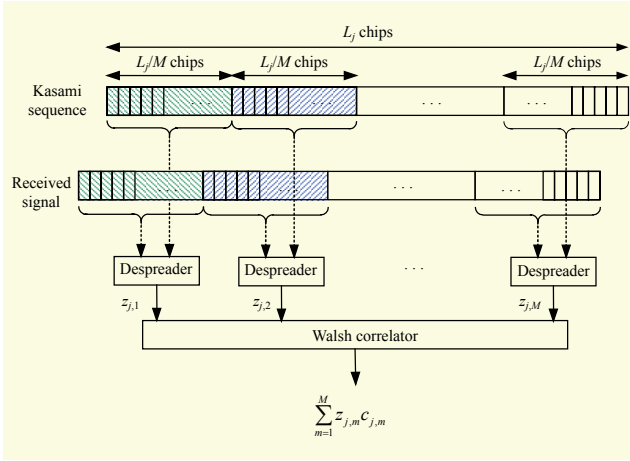

Fig. 7. Despreading by Kasami sequence.

where

$$z_{j,m}(n) = \rho v_j c_{j,m} \otimes h + d(n) \otimes h \cdot x(n) + w(n) \cdot x(n),$$

$$(j-1)L_j + \frac{(m-1)L_j}{M} \leq n \leq (j-1)L_j + \frac{mL_j}{M}. \quad (9)$$

Recall that since the transmitted Walsh sequence is spread by the Kasami sequence of length  $L_j$  chips, each element of the Walsh sequence is spread by  $L_j/M$  chips of the Kasami sequence. Hence, as shown in Fig. 7, the received signal is despread by  $L_j/M$  chips of the Kasami sequence corresponding to each element of the Walsh sequence.

Let  $z_{j,m}$ ,  $m=1, \dots, M-1$ , denote the despread signal by  $L_j/M$  chips of the Kasami sequence corresponding to the  $m$ -th element of the Walsh sequence during  $j$ -th Kasami sequence duration. The despread signal,  $z_{j,m}$ ,  $j=1, \dots, 4$ ,  $m=1, \dots, M$ , can then be written as

$$\begin{aligned} z_{j,m} &= \sum_{n=(j-1)L_j + \frac{(m-1)L_j}{M}}^{(j-1)L_j + \frac{mL_j}{M}} r(n)x(n) \\ &= \sum_{n=(j-1)L_j + \frac{(m-1)L_j}{M}}^{(j-1)L_j + \frac{mL_j}{M}} z_{j,m}(n) \\ &= \sum_{n=(j-1)L_j + \frac{(m-1)L_j}{M}}^{(j-1)L_j + \frac{mL_j}{M}} \left\{ \rho v_j c_{j,m} \otimes h \right\} \\ &\quad + \sum_{n=(j-1)L_j + \frac{(m-1)L_j}{M}}^{(j-1)L_j + \frac{mL_j}{M}} \left\{ d(n) \otimes h \cdot x(n) + w(n) \cdot x(n) \right\} \\ &= \frac{L_j}{M} \rho v_j c_{j,m} \otimes h \\ &\quad + \sum_{n=(j-1)L_j + \frac{(m-1)L_j}{M}}^{(j-1)L_j + \frac{mL_j}{M}} \left\{ d(n) \otimes h \cdot x(n) + w(n) \cdot x(n) \right\}. \quad (10) \end{aligned}$$

Now, the despread signal  $z_{j,m}$ ,  $m=1, \dots, M-1$ , is correlated with the Walsh sequences. The cross-correlation between  $\{z_{j,1}, \dots, z_{j,M}\}$  and the Walsh sequence  $\mathbf{c}_j = \{c_{j,1}, \dots, c_{j,M}\}$  is given by

$$\begin{aligned} \sum_{m=1}^M z_{j,m} c_{j,m} &= \sum_{m=1}^M \left\{ \frac{L_j}{M} \rho v_j c_{j,m} \otimes h \right\} \cdot c_{j,m} \\ &\quad + \sum_{m=1}^M \sum_{n=(j-1)L_j + \frac{(m-1)L_j}{M}}^{(j-1)L_j + \frac{mL_j}{M}} \left\{ d(n) \otimes h \cdot x(n) \right\} \cdot c_{j,m} \\ &\quad + \sum_{m=1}^M \sum_{n=(j-1)L_j + \frac{(m-1)L_j}{M}}^{(j-1)L_j + \frac{mL_j}{M}} \left\{ w(n) \cdot x(n) \right\} \cdot c_{j,m} \\ &= L_j \rho v_j \otimes h \\ &\quad + \sum_{n=(j-1)L_j+1}^{jL_j} \left\{ d(n) \otimes h \cdot x(n) \cdot c_{j,m} \right\} \\ &\quad + \sum_{n=(j-1)L_j+1}^{jL_j} \left\{ w(n) \cdot x(n) \cdot c_{j,m} \right\}. \quad (11) \end{aligned}$$

The Walsh sequence is detected by choosing the resulting correlation peak as

$$\hat{\mathbf{c}}_j = \arg \max_{\mathbf{c}_j \in \{\mathbf{w}_1, \dots, \mathbf{w}_M\}} \left| \sum_{m=1}^M z_{j,m} c_{j,m} \right|. \quad (12)$$

Note that  $\sum_{m=1}^M z_{j,m} c_{j,m}$  is the correlation between the Walsh sequence  $\mathbf{c}_j$  and the despread signal  $z_{j,m}$ , and thus can efficiently be computed using the fast Walsh transform (FWT) [8]. An  $M$ -point FWT is applied to  $(z_{j,1}, \dots, z_{j,M})$ , which gives  $\sum_{m=1}^M z_{j,m} c_{j,m}$  in (12). The computation of an  $M$ -point FWT requires  $M \log_2 M$  additions [8]. Hence,  $M^2 \log_2 M$  additions are required to compute (12).

Finally, we can obtain the polarity data  $\hat{v}_j$  by detecting the sign of the correlation peak for the detected Walsh sequence  $\hat{\mathbf{c}}_j = \{\hat{c}_{j,1}, \dots, \hat{c}_{j,M}\}$  as

$$\hat{v}_j = \text{sgn} \left\{ \sum_{m=1}^M z_{j,m} \hat{c}_{j,m} \right\}. \quad (13)$$

Note that since four Walsh sequences are transmitted during one field, and the duration of one field is 24.2 ms, the achievable data rate<sup>1)</sup> of the proposed scheme is

$$\frac{4(1 + \log_2 M)}{24.2 \times 10^{-3}} \text{ (bps)}. \quad (14)$$

1) The maximum achievable data rate of the proposed scheme is 2.645 kbps (64 bits/24.2 ms) with  $M=2^{15}$ .

#### IV. Performance Analysis

We assume that channel  $h$  is constant during the transmission of at least one Kasami sequence. From (11), we can observe that the first term of the right side of (11) is the desired signal component, and the second term of the right side of (11) is the interference component due to the original DTV signal. Also, the third term of the right side of (11) is the noise component.

At the receiver, since the interference is despread by the Kasami sequence, we can assume that the interference component is modeled as Gaussian noise with variance  $\sigma_d^2$ . Then, at the output of the Walsh correlator, the SNR  $\gamma$  can be written as

$$\gamma = 10 \log_{10} \frac{L_j \rho \sigma_d^2}{\sigma_d^2 + \sigma_w^2}, \quad (15)$$

where  $\sigma_d^2$  denotes the received DTV signal power, and  $\sigma_w^2$  denotes the noise variance<sup>2)</sup>.

Then, (15) can be rearranged as

$$\gamma = 10 \log_{10} L_j + 10 \log_{10} \frac{\rho \sigma_d^2}{\sigma_d^2 + \sigma_w^2}. \quad (16)$$

Note that the first term indicates the spreading gain by the Kasami sequence.

On the other hand, the carrier-to-noise ratio (CNR) can be written as

$$\begin{aligned} \text{CNR} &= 10 \log_{10} \frac{\sigma_d^2 + \rho \sigma_d^2}{\sigma_w^2} \\ &= 10 \log_{10} \frac{\sigma_d^2}{\sigma_w^2} + 10 \log_{10} (1 + \rho). \end{aligned} \quad (17)$$

Then, from (16) and (17),  $\gamma$  can be computed as

$$\gamma = 10 \log_{10} L_j + \text{CNR} + 10 \log_{10} \left( \frac{\rho}{1 + \rho + 10^{\text{CNR}/10}} \right). \quad (18)$$

As shown in (12) and (13), the detection rule of the proposed scheme can be interpreted as the detection rule of  $M$ -ary bi-orthogonal signaling. Therefore, we can obtain the symbol error rate (SER) of the proposed scheme as follows [9]:

$$P_S = 1 - \frac{1}{\sqrt{2\pi}} \int_{-\sqrt{2\gamma}}^{\infty} \left( \frac{1}{\sqrt{2\pi}} \int_{-(v+\sqrt{2\gamma})}^{v+\sqrt{2\gamma}} e^{-x^2/2} dx \right)^{M/2-1} e^{-v^2/2} dv. \quad (19)$$

Simulation results show that the interference component at the output of the Walsh correlator is well approximated as

2) Note that the DTV signal acts as an interference signal to the TxID signal. The power of the TxID signal is  $\rho \sigma_d^2$  and the power of interference plus noise is  $(\sigma_d^2 + \sigma_w^2)$ . Also, the spreading gain at the output of the Walsh correlator is  $L$ .

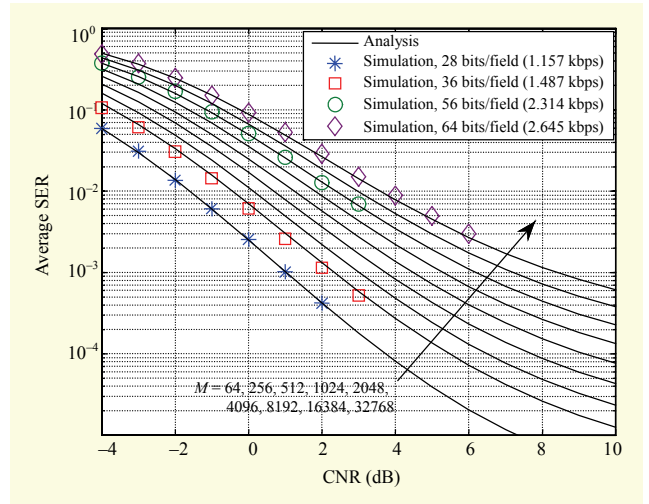

Fig. 8. Average SER curves of proposed scheme under AWGN.

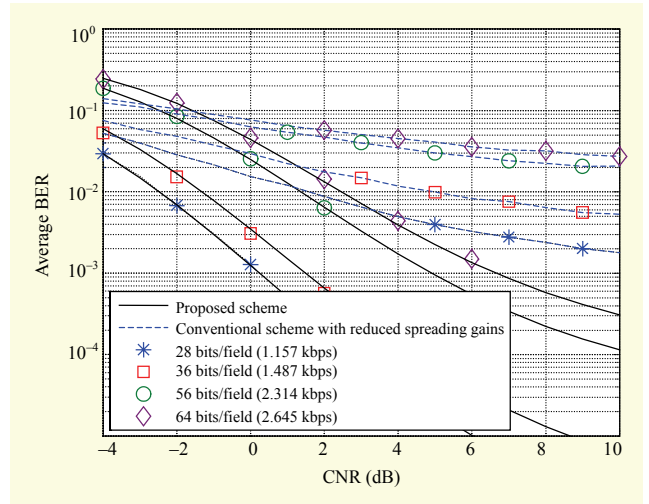

Fig. 9. Average BER curves of conventional scheme with reduced spreading factors under AWGN.

Gaussian noise and that the analytical form in (19) accurately predicts the SER of the proposed scheme.

#### V. Numerical Results

For all simulation results presented in this section, we assume that the injection level is  $-30$  dB, that is,  $\rho=0.1449$ . Figure 8 shows the average SER performance of the proposed scheme versus CNR under an additive white Gaussian noise (AWGN) channel. As shown in Fig. 8, the proposed scheme achieves a data rate of 2.314 kbps (56 bits/24.2 ms) with an SER of less than  $10^{-3}$  under CNRs greater than 8 dB, which is approximately 11 times higher than the achievable data rate of [5] with 4-PAM. When the resulting sequence is injected 30 dB below the DTV signal, and  $M$  is set to 64, the proposed scheme



can achieve a data rate of 1.157 kbps (28 bits/24.2 ms) with an SER of less than  $10^{-3}$  at CNRs greater than 1 dB, which is approximately 6 times higher than the achievable data rate of [5] with 4-PAM. Also, Fig. 8 shows that the analytical form (19) for the SER of the proposed scheme accurately predicts the simulation results.

Figure 9 shows the average bit error rate (BER) performance of the straightforward scheme with reduced spreading factors. We can observe that the performance of the straightforward scheme is severely degraded compared to the proposed scheme.

## VI. Conclusion

In this paper, we proposed a novel data transmission scheme using TxID and Walsh sequences in ATSC DTV systems. The proposed scheme transmits data bits using a Walsh sequence and its polarity. The proposed scheme significantly enhances the data rate compared to the conventional schemes. The performance of the proposed scheme was theoretically analyzed. Also, the proposed scheme allows for an efficient receiver structure using an FWT.

## References

- [1] ATSC, "Standard A/110: Synchronization Standard for Distributed Transmission," Advanced Television Systems Committee, Washington, D.C., July 2004.
- [2] ATSC, "Recommended Practice A/111: Design of Synchronized Multiple Transmitter Networks," Advanced Television Systems Committee, Washington, D.C., Sept. 2004.
- [3] S.I. Park et al., "Transmitter Identification Signal Analyzer for Single Frequency Network," *IEEE Trans. Broadcasting*, vol. 54, no. 3, Sept. 2008, pp. 383-393.
- [4] S.I. Park, H.M. Kim, and W. Oh, "Reception Power Estimation Using Transmitter Identification Signal for Single Frequency Network," *IEEE Trans. Broadcasting*, vol. 55, no. 3, Sept. 2009, pp. 652-655.
- [5] X. Wang, Y. Wu, and J.-Y. Chouinard, "Robust Data Transmission Using the Transmitter Identification Sequences in ATSC DTV Signals," *IEEE Trans. Consum. Electron.*, vol. 51, no. 1, Feb. 2005, pp. 41-47.
- [6] S.I. Park et al., "An Efficient Receiver Structure for Robust Data Transmission Using TxID Signal in the ATSC DTV System," *IEEE Trans. Consum. Electron.*, vol. 56, no. 2, May 2010, pp. 408-414.
- [7] ATSC, "Standard A/53: ATSC digital Television Standard," Jan. 2007.
- [8] K.G. Beauchamp, *Applications of Walsh and Related Functions*, London: Academic Press, 1984.
- [9] J.G. Proakis, *Digital Communications*, McGraw-Hill, 1995.



**Sung Ik Park** received his BSEE from Hanyang University, Seoul, Rep. of Korea, in 2000; his MSEE from Pohang University of Science and Technology (POSTECH), Pohang, Rep. of Korea, in 2002; and his PhD from Chungnam National University, Daejeon, Rep. of Korea, in 2011. Since 2002, he has been with

the Broadcasting System Research Group, ETRI, Rep. of Korea, where he is a senior member of the research staff. His research interests are in the area of error correction codes and digital communications, in particular, signal processing for digital television. In 2009, he received the IEEE Scott Helt Memorial Award for the best paper on broadcasting.

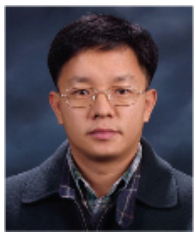

**Heung Mook Kim** received his BSEE and MSEE in electronics and electrical engineering from Pohang University of Science and Technology (POSTECH), Pohang, Korea, in 1993 and 1995, respectively. From February 1995 to January 2002, he was a research engineer with POSCO Technology Laboratory

in the field of measurement and monitoring. Since February 2004, he has been with the Broadcasting System Research Department at ETRI, Rep. of Korea, where he is the director of the Terrestrial Broadcasting Technology Research Team. His research interests are digital and RF signal processing and RF transmission for digital communication and digital television.

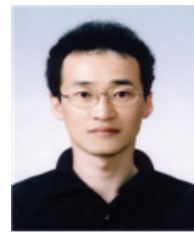

**Wangrok Oh** received his BS, MS, and PhD from Pohang University of Science and Technology (POSTECH), Pohang, Rep. of Korea, in 1994, 1997, and 2003, respectively. From 1997 to 2000 and from 2003 to 2006, he was with POSTECH Information Laboratories (PIRL), Rep. of Korea, as a full-time member of

the research staff and worked for the development of various communications systems. He is currently with Chungnam National University, Daejeon, Rep. of Korea, as an assistant professor. His current research interests include turbo and turbo-like codes, design and implementation of various communication systems, space-time codes, and MIMO systems.



**Jeongchang Kim** received his BS in electronics, communication, and radio engineering from Hanyang University, Seoul, Rep. of Korea, in 2000, and his MS and PhD from Pohang University of Science and Technology (POSTECH), Pohang, Rep. of Korea, in 2002 and 2006, respectively, both in

electronic and electrical engineering. From 2006 to 2008, he was with

POSTECH Information Laboratories (PIRL), Rep. of Korea, as a full-time member of the research staff. From 2008 to 2009, he was with the Educational Institute of Future Information Technology at POSTECH as an assistant research professor. From 2009 to 2010, he was with the Broadcasting Systems Research Department at ETRI, Rep. of Korea, as a senior member of the engineering staff. In 2010, he joined the Department of Electronics and Communications Engineering at Korea Maritime University, Busan, Rep. of Korea, where he is currently a professor. His current research interests include MIMO, space-time codes, OFDM, and marine communications and implementation of digital communication systems.