

## Highly power-efficient and reliable light-emitting diode backlight driver IC for the uniform current driving of medium-sized liquid crystal displays

Seok-In Hong, Ki-Soo Nam, Young-Ho Jung, Hyun-A Ahn, Hai-Jung In, and Oh-Kyong Kwon\*

*Department of Electronic Engineering, Hanyang University, 222 Wangsimni-ro Seongdong-gu, Seoul 133-791, South Korea*

*(Received 15 January 2012; Revised 17 February 2012; Accepted for publication 1 March 2012)*

In this paper, a light-emitting diode (LED) backlight driver integrated circuit (IC) for medium-sized liquid crystal displays (LCDs) is proposed. In the proposed IC, a linear current regulator with matched internal resistors and an adaptive phase-shifted pulse-width modulation (PWM) dimming controller are also proposed to improve LED current uniformity and reliability. The double feedback loop control boost converter is used to achieve high power efficiency, fast transient characteristic, and high dimming frequency and resolution. The proposed IC was fabricated using the 0.35  $\mu\text{m}$  bipolar-CMOS-DMOS (BCD) process. The LED current uniformity and LED fault immunity of the proposed IC were verified through experiments. The measured power efficiency was 90%; the measured LED current uniformity, 97%; and the measured rising and falling times of the LED current, 86 and 7 ns, respectively. Due to the fast rising and falling characteristics, the proposed IC operates up to 39 kHz PWM dimming frequency, with an 8-bit dimming resolution. It was verified that the phase difference between the PWM dimming signals is changed adaptively when LED fault occurs. The experiment results showed that the proposed IC meets the requirements for the LED backlight driver IC for medium-sized LCDs.

**Keywords:** LED; backlight; boost converter; adaptive phase-shifted PWM; double feedback loop control

### 1. Introduction

Many types of backlight units (BLUs) have been developed for liquid crystal displays (LCDs), such as cold cathode fluorescent lamps, external electrode fluorescent lamps, flat fluorescent lamps, and light-emitting diodes (LEDs). Among these backlight candidates, the LED backlight is most suitable for all LCD sizes due to the many advantages of LEDs, such as low power consumption, wide color gamut, high contrast ratio, thin thickness, dimming capability, and environment friendliness [1–4].

To use LEDs for BLUs, the LED backlight driver integrated circuit (IC) should achieve high power efficiency, accurate and uniform current control for LEDs, fast transient characteristic, high dimming frequency, high dimming resolution, and high reliability. Many researches have been conducted to achieve these requirements of the LED backlight driver IC [5–8]. To improve its power efficiency, the dynamic voltage headroom control method and the self-adaptive driving method were proposed [5,6]. The dynamic voltage headroom control method effectively reduces the power consumption of the LED backlight driver IC by dynamically and optimally tracking the driving voltage of the LED backlight [5]. The self-adaptive driving method further reduces the power consumption by eliminating the driving voltage margin of the current regulators [6]. The main drawbacks of these methods [5,6], however,

are their low pulse-width modulation (PWM) dimming frequency and resolution due to their poor transient characteristics. As a low PWM dimming frequency can cause audible noise, the dimming frequency should be higher than the maximum audible frequency (20 kHz) [7]. To achieve high power efficiency, fast transient characteristic, and high dimming frequency and resolution, the double feedback loop control boost converter was proposed [8]. There are many methods that can be used to regulate the LED current for the improvement of the current accuracy of each LED channel, such as the current mirror, current regulator, linear current regulator, switch-mode current regulator, and linear current regulator with a switch-mode pre-regulator. Among these methods, the linear current regulator with a switch-mode pre-regulator is mainly used due to its high accuracy and power efficiency [6]. Current uniformity between the LED channels, however, is not guaranteed by the linear current regulator with a switch-mode pre-regulator. It should be required to enhance current uniformity for the multichannel LED backlight driver IC. To improve the reliability of the LED backlight driver IC, LED open or short fault should be detected to prevent the breakdown of the LED driver IC. The flicker and audible noises generated by LED open or short fault, however, are not removed by LED fault detection and protection.

---

\*Corresponding author: Email: okwon@hanyang.ac.kr

In this paper, an LED backlight driver IC for medium-sized LCDs is proposed. To improve LED current uniformity and reliability, the linear current regulator with matched internal resistors and the adaptive phase-shifted PWM dimming controller are proposed. The proposed LED backlight driver IC will be explained in Section 2, and the experiment results and a discussion of the proposed LED backlight driver IC will be presented in Section 3.

## 2. The proposed LED backlight driver IC

### 2.1. The proposed system configuration

The proposed system configuration of the LED backlight driver IC for medium-sized LCDs is shown in Figure 1. The LED driver IC consists of a boost converter, linear current regulators, and an adaptive phase-shifted PWM dimming controller. The boost converter generates a supply voltage for LEDs, and the linear current regulator determines the current of each LED channel. In this system, a linear current regulator with matched internal resistors is proposed to promote LED current uniformity, and an adaptive phase-shifted PWM dimming controller is proposed to improve the immunity of LED from open or short fault. The double feedback loop control boost converter [8] is used to improve the power efficiency and transient characteristic of the boost converter. The proposed adaptive phase-shifted PWM driver transfers the PWM signals to each linear current regulator. The output voltage of the boost converter and the channel voltage (the voltage at the upper node of the current regulator in each LED channel)

of all the LED channels are used as feedback data to improve the power efficiency and transient characteristic of the boost converter, and to detect LED open or short fault.

### 2.2. Highly power-efficient boost converter

To improve the power efficiency and transient characteristic of the boost converter in the LED driver IC, the double feedback loop control boost converter is used [8]. Its schematic diagram is shown in Figure 2 [8]. The double feedback loop control boost converter consists of a current-programmed control boost converter [9] and an adaptive reference voltage generator. The adaptive reference voltage generator generates the adaptive reference voltage ( $V_{AREF}$ ) and transfers it to the reference voltage node of the current-programmed control boost converter. To guarantee the operation of all the LED channels and to optimize the supply voltage of the LEDs, the adaptive reference voltage is determined by the channel voltage in the channel that has the worst LED forward voltage characteristic in the adaptive reference voltage generator.

There are two feedback loops in the double feedback loop control boost converter. The first feedback loop is the boost converter output voltage regulation loop. This loop is the same as that of the current-programmed control boost converter [9], except for the adaptive reference voltage. As the output voltage of the boost converter is regulated by this loop, the transient response of the boost converter does not depend on the LED current. In other words, the

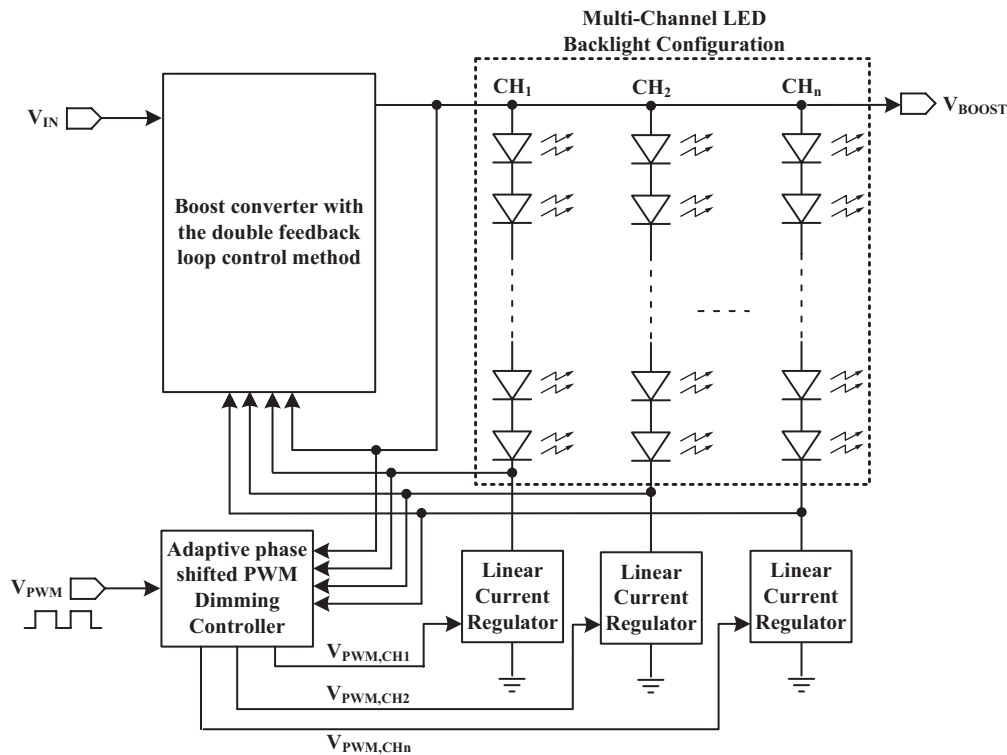

Figure 1. System configuration of the proposed LED backlight driver IC for medium-sized LCDs.

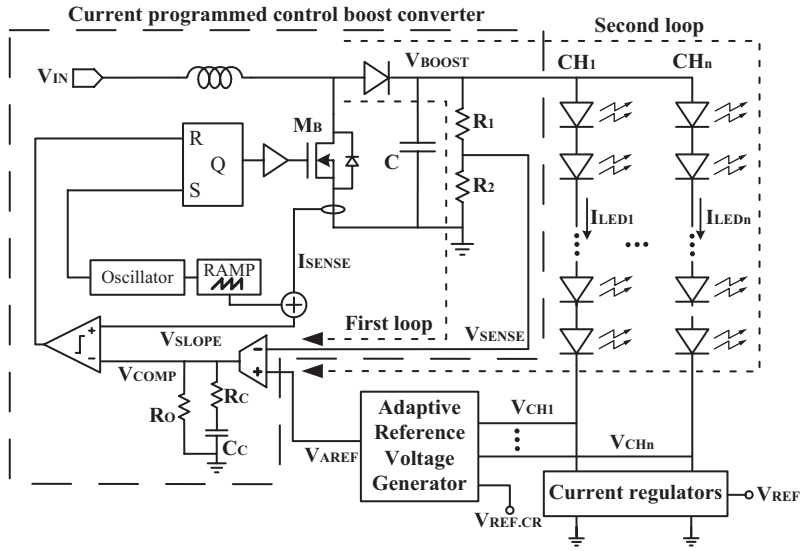

Figure 2. Schematic diagram of the double feedback loop control boost converter.

LED current is not coupled to the transient response of the boost converter. The transient characteristic of the LED current is determined only by the current regulator, and fast LED current transient characteristic is achieved. The second feedback loop is the reference voltage generation loop for controlling the output voltage of the boost converter, which is determined by the second loop for voltage headroom control, as shown in Equation (1).

$$V_{\text{BOOST}} = \sum V_{\text{LED-}n} + V_{\text{REF-CR}}, \quad (1)$$

where  $V_{\text{BOOST}}$  is the output voltage of the boost converter,  $V_{\text{LED-}n}$  is the forward voltage of each LED in the channel that has the worst LED forward voltage characteristic, and

$V_{\text{REF-CR}}$  is the reference voltage of the adaptive reference voltage generator. The channel voltage of the channel that has the worst LED forward voltage characteristic is regulated by  $V_{\text{REF-CR}}$ , and a voltage margin of the current regulator is no longer required. As the wasted power consumption of the current regulator is removed, the power efficiency of the LED backlight driver IC is improved. The  $V_{\text{REF-CR}}$  is designed to guarantee the optimum operation voltage of the current regulator. In a design using the linear current regulator, the  $V_{\text{REF-CR}}$  is typically 200–400 mV to reduce power consumption. Therefore, the fast transient characteristic of the LED current and the high power efficiency of the LED backlight driver IC are achieved via double feedback loop control.

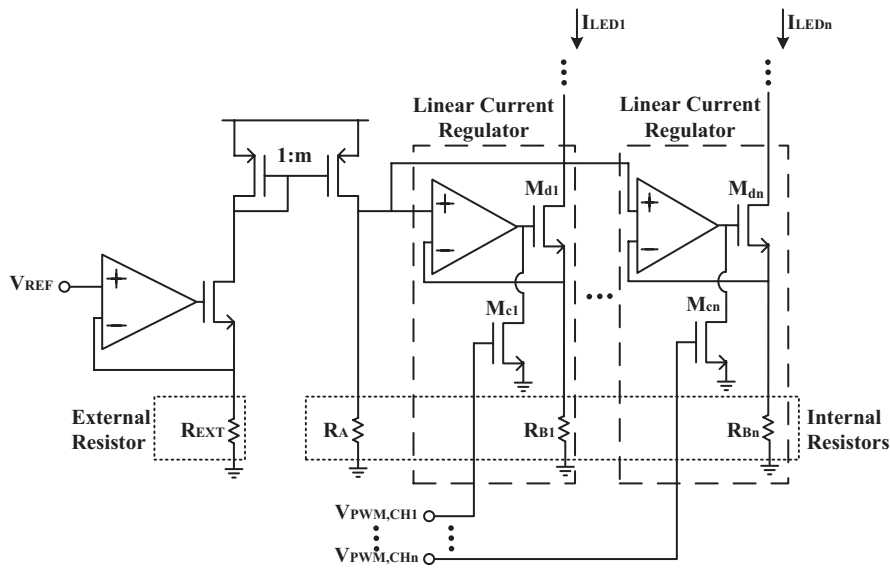

Figure 3. The proposed linear current regulator with matched internal resistors.

### 2.3. The proposed linear current regulator with matched internal resistors

The luminance of each LED channel is determined by the current of each LED channel. In the case where a linear current regulator is used to control the LED channel current, the current is determined by the reference voltage and the resistance of the internal resistor. In this case, the current uniformity of the LED channels in the conventional linear current regulator is deteriorated by the resistance

variation of the internal resistor, which is caused by process variations. To improve current uniformity, the linear current regulator with matched internal resistors is proposed. Figure 3 shows the proposed linear current regulator in the LED backlight driver IC.  $M_{d1}-M_{dn}$  are driving transistors for driving the LED current, and  $M_{c1}-M_{cn}$  are control transistors for controlling the on-duty of the LED current.  $R_{EXT}$  is an external resistor for setting the LED current,  $R_A$  and  $R_{B1}-R_{Bn}$  are internal resistors, and  $V_{REF}$  is the bandgap

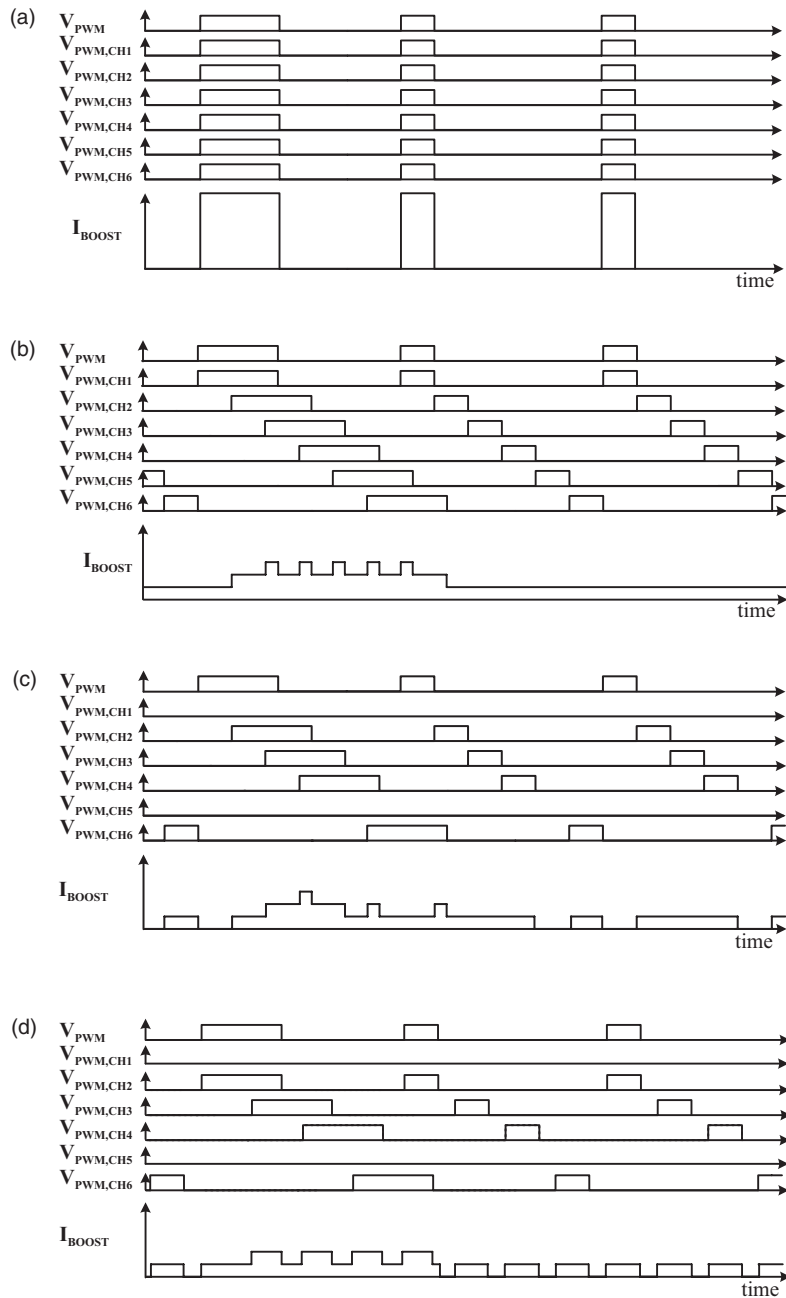

Figure 4. Timing diagram of the (a) PWM dimming signals without the phase-shifted PWM driving method; (b) phase-shifted PWM dimming signals; (c) phase-shifted PWM dimming signals with LED open fault at LED channels 1 and 5; and (d) adaptive phase-shifted PWM dimming signals with LED open fault at LED channels 1 and 5.

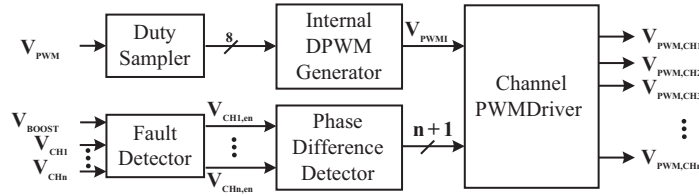

Figure 5. Block diagram of the proposed adaptive phase-shifted PWM dimming controller.

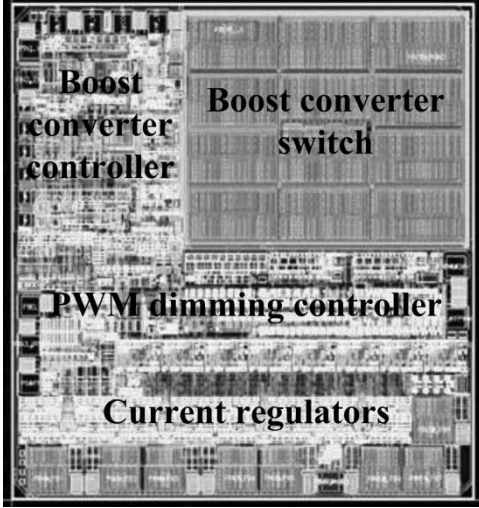

Figure 6. Layout of the proposed LED backlight driver IC.

reference voltage. The LED current in each LED channel is expressed as shown in Equation (2).

$$I_{LED-n} = \frac{V_{REF}}{R_{EXT}} \times m \times \frac{R_A}{R_{Bn}}, \quad (2)$$

where  $m$  is the ratio of the current mirror. Equation (2) shows that the current-matching characteristic among all the LED channels was not dependent on the resistance of the internal resistor but on the resistance-matching characteristic between  $R_A$  and  $R_{Bn}$ . As the difference between resistance variations of the two internal resistors was about 0.1% in one chip, current uniformity among all the LED channels

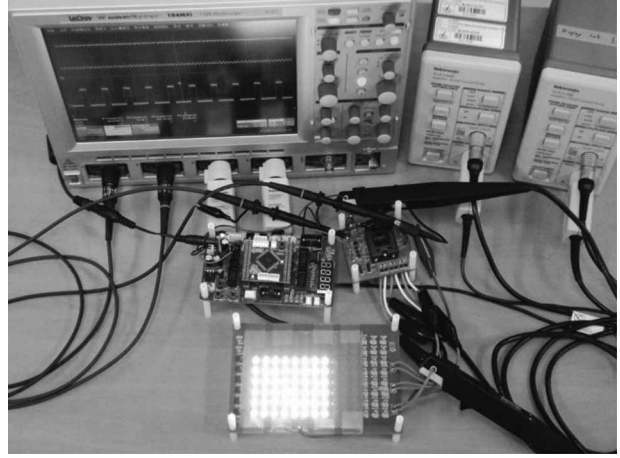

Figure 7. The developed prototype of the proposed LED backlight driver IC.

was improved by the proposed linear current regulator with matched internal resistors.

#### 2.4. The proposed adaptive phase-shifted PWM dimming controller

In the case of the multichannel LED backlight driver IC, the PWM dimming method is used to control the luminance of the LED backlight and to maintain the uniformity of the color temperature in a display [1]. If all the LED channels with the same PWM phase are turned on simultaneously, however, the output current of the boost converter will change abruptly, as shown in Figure 4(a), which will degrade the EMI performance, decrease the

Table 1. Performance comparison with prior works.

	MAXIM/Dallas Semiconductor [11]	TEXAS INSTRUMENTS [12]	INTERSIL [13]	This work
Maximum $V_{IN}$ (V)	26	24	24	27
Minimum $V_{IN}$ (V)	4.5	5	6	6
Maximum $V_{BOOST}$ (V)	45	40	34.5	60
Maximum $I_{LED}$ (mA)	30	25	30	30
Minimum $I_{LED}$ (mA)	15	0	0	0
Peak efficiency (%)	87	89	88	90
No. of channels	8	6	8	6
$t_{rising}$ of $I_{LED}$ ( $\mu$ s)	15	—	—	0.086
Maximum $f_{PWM}$ (kHz)	2	5	5	39
Minimum PWM on-duty cycle at maximum $f_{PWM}$ (%)	1	5	1	0.4

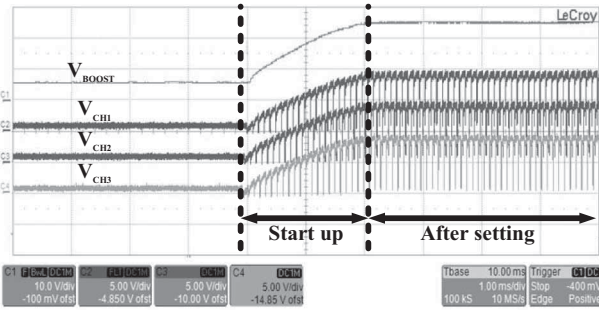

Figure 8. The measured output voltage transient response and waveforms of the channel voltages during start-up operation.

power efficiency, and increase the supply voltage ripple of the LEDs. To prevent these problems, the phase-shifted PWM driving method shown in Figure 4(b) is proposed [3]. In this method, the PWM signals of all the LED channels

have the same PWM on-duty cycle, but each PWM signal is started at a different time. The phase difference between the PWM signals was determined to be  $360^\circ/n$ , which is the number of LED channels. As a result, the output current of the boost converter changes as much as the current in one LED channel, and abrupt changes in the output current of the boost converter are avoided.

There is another problem, however, in the case of the multichannel LED backlight driver IC using the adaptive phase-shifted PWM driving method. If any LED channel is faulted during normal operation, the periodicity of the boost converter's output current decreases, and harmonic noise can be generated in the LED backlight, as shown in Figure 4(c). In this figure, it is assumed that among the six LED channels, LED channels 1 and 5 are disabled. To improve the periodicity of the output current, and to remove the harmonic noise, the adaptive phase-shifted PWM driving method is proposed. The timing diagram of

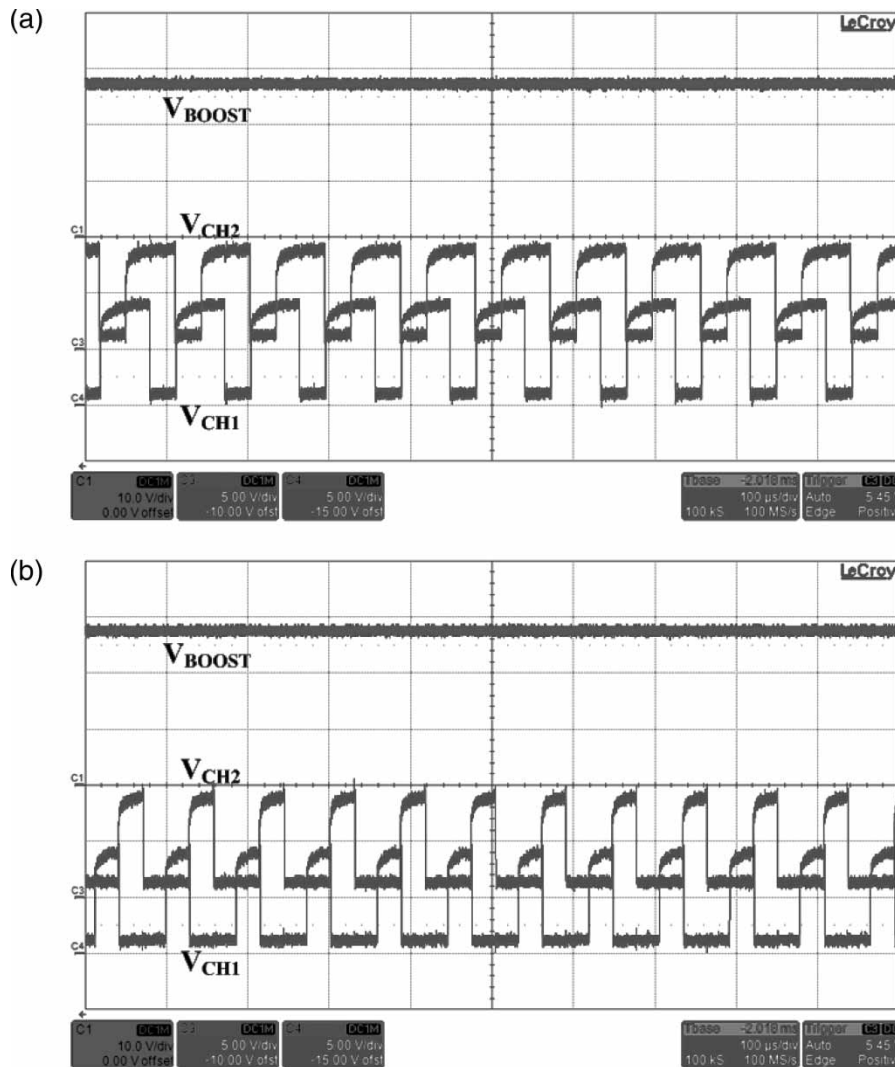

Figure 9. Output voltage of the boost converter and LED channel voltages during normal operation when the PWM on-duty was (a) 33% and (b) 66%.

the proposed adaptive phase-shifted PWM driving method is shown in Figure 4(d). In the proposed method, the enabled and disabled LED channels are detected, and the phase difference between the PWM signals of the enabled LED channels is recalculated according to the number of enabled channels. Therefore, the periodicity of the output current is improved, and the harmonic noise in the LED backlight can be removed.

The block diagram of the proposed adaptive phase-shifted PWM dimming controller is shown in Figure 5. The duty sampler gathers the PWM on-duty information from the external PWM dimming signal ( $V_{PWM}$ ), and the internal PWM generator generates the internal PWM reference signal ( $V_{PWMI}$ ).  $V_{PWMI}$  has the same PWM on-duty as  $V_{PWM}$ , but its frequency is different from that of  $V_{PWM}$ . The fault detector detects the LED open or short fault and generates the enable signals ( $V_{CHn-en}$ ) of each channel. The phase

difference detector generates the phase difference between the PWM signals of the enabled LED channels according to the number of such channels. The channel PWM driver transfers the internal PWM signal to the current regulator of each LED channel according to the phase difference data transferred from the phase difference detector.

### 3. Results and discussion

Figure 6 shows the layout of the proposed LED backlight driver IC. At the top of the chip are the boost converter controller and the boost converter switch. The PWM dimming controller is at the center of the chip. For the regulation of the LEDs, six-channel linear current regulators were placed at the bottom of the chip. The chip was fabricated through the  $0.35\text{ }\mu\text{m}$  bipolar–CMOS–DMOS (BCD) process because of the latter's high voltage-blocking capability and latch-up

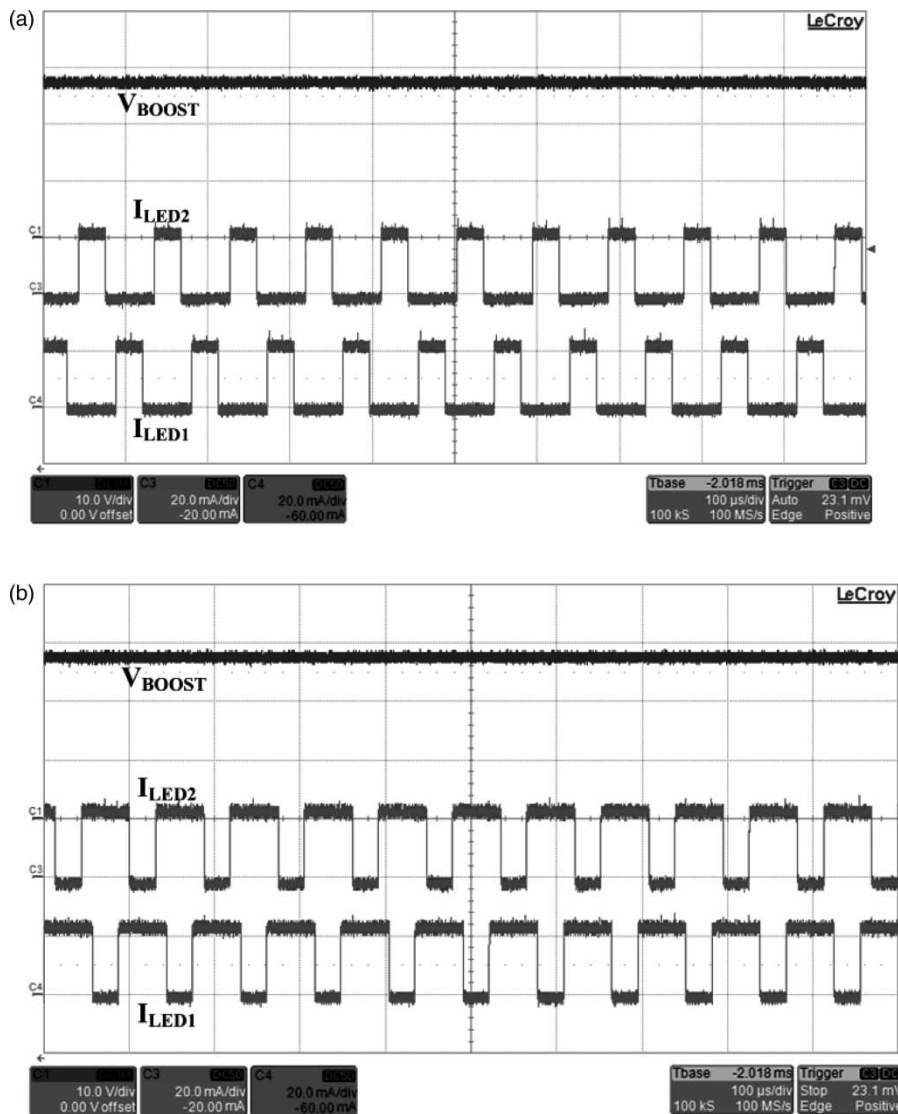

Figure 10. Output voltage of the boost converter and current of the two LED channels during normal operation when the PWM on-duty was (a) 33% and (b) 66%.

immunity. For the measurement, three LED channels with eight series-connected IWS-351-UW-A2 LEDs [10] were used, and the current in an LED channel was set at 22 mA. A 4.7  $\mu$ H inductor and a 4.7  $\mu$ F capacitor were used, and the used frequency of the external PWM signal was 100 Hz. The developed prototype is shown in Figure 7, and the

performance of the system is compared with those of similar commercial products in Table 1 [11–13].

Figure 8 shows the measured output voltage transient response and waveforms of the channel voltages ( $V_{CH1}$ ,  $V_{CH2}$ , and  $V_{CH3}$ ) during start-up operation. The output voltage of the boost converter,  $V_{BOOST}$ , continuously

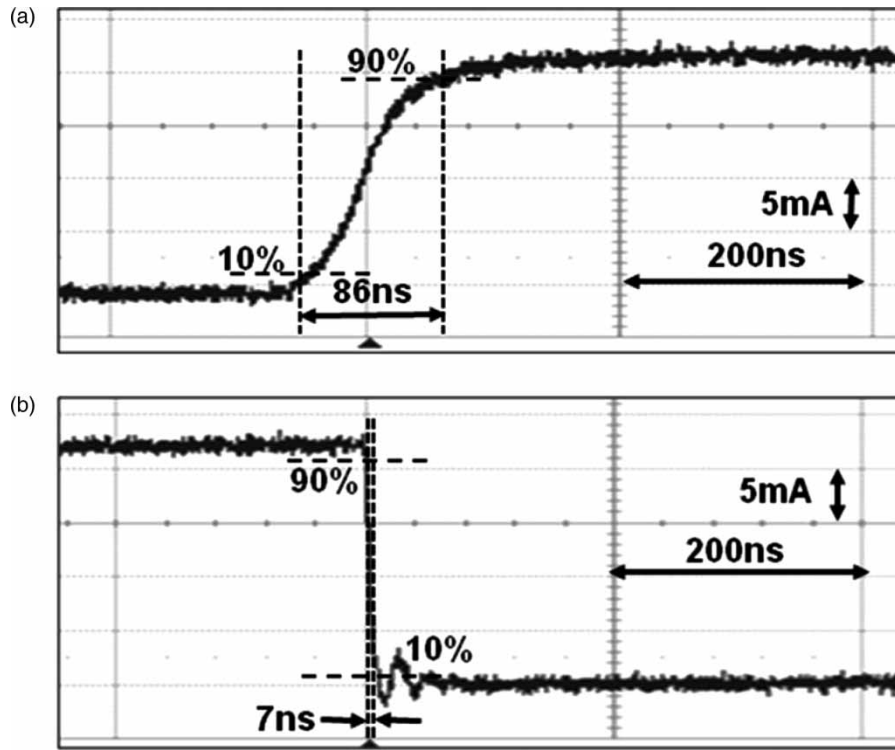

Figure 11. LED current waveforms: (a) rising transient response; and (b) falling transient response.

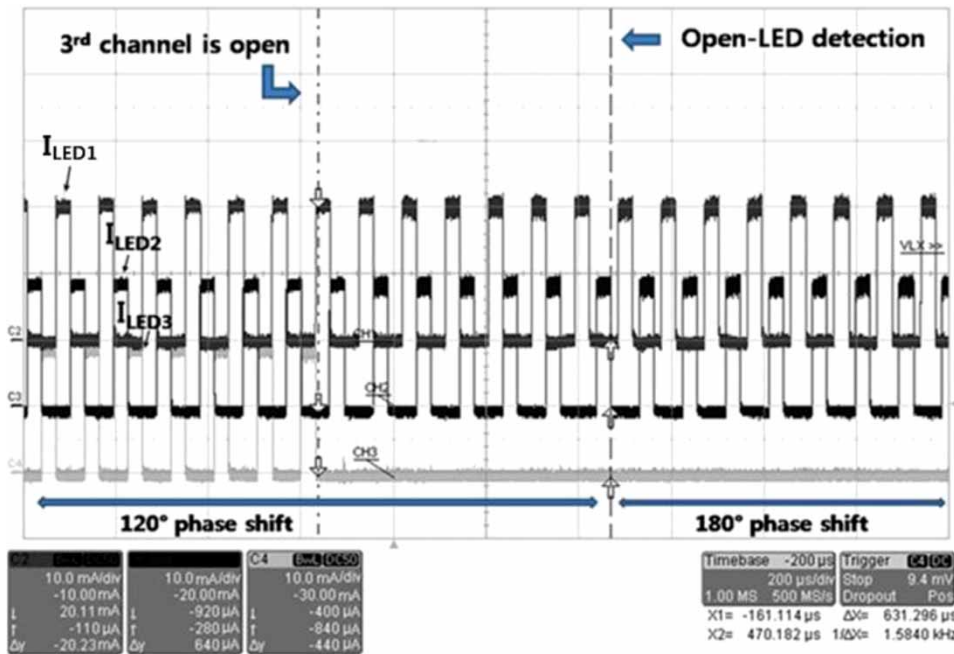

Figure 12. LED current waveforms during the operation of the proposed adaptive phase-shifted PWM dimming controller.



increased until all the channel voltages settled at  $V_{REF}$ . Figure 9(a) and (b) shows the output voltage of the boost converter and the LED channel voltages during normal operation, when the PWM on-duty was 33 and 66%, respectively. Figure 10(a) and (b) shows the output voltage of the boost converter and the current of the two LED channels during normal operation, when the PWM on-duty was 33 and 66%, respectively. During normal operation, the output voltage of the boost converter,  $V_{BOOST}$ , was 26.41 V, and the current in each LED channel was 22 mA. Moreover, 97% current uniformity was achieved among all the LED channels. It was thus verified that the proposed linear current regulator with matched internal resistors promotes current uniformity among all LED channels. Figure 11(a) and (b) shows that the rising and falling times of the LED current are 86 and 7 ns, respectively. As the rising time is determined by the slewing time of the amplifier, and as the falling time is determined by the discharging time of the control transistor, asymmetry of the rising and falling times is shown in Figure 11(a) and (b), respectively. Due to the fast rising and falling characteristics, the proposed LED backlight driver operates up to 39 kHz PWM dimming frequency with a minimum PWM on-duty of 0.4%. The PWM frequency is approximately eight times higher than the previously published results [11–13]. Figure 12 demonstrates the operation of the proposed adaptive phase-shifted PWM dimming controller. Before the opening of the third LED channel, all the LED channels are enabled, and the phase difference between the current waveforms of the LED channels is  $120^\circ$ . After the opening of the third LED channel, the current in such LED channel becomes zero. As no open LED fault of the third LED channel has yet been detected, the phase difference between the current waveforms of the enable LED channels is still  $120^\circ$ . After the detection of an open LED fault of the third LED channel, the phase difference between the current waveforms of the enabled LED channels becomes  $180^\circ$ , and there is no harmonic noise.

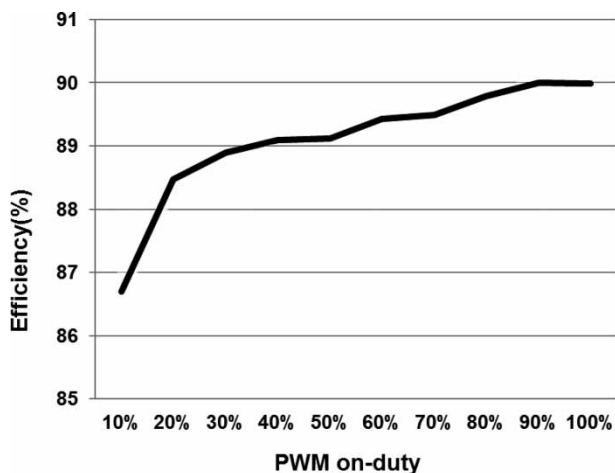

Figure 13. The measured power efficiency of the boost converter versus PWM on-duty.

Therefore, it was verified that the proposed adaptive phase-shifted PWM dimming controller removes the harmonic noise. The measured power efficiency of the boost converter versus the PWM on-duty is shown in Figure 13. The proposed LED backlight driver IC achieves 90% maximum power efficiency despite the additional power.

#### 4. Conclusion

A new LED backlight driver IC is proposed to achieve high power efficiency, fast transient characteristic, high LED current uniformity, and LED fault immunity for medium-sized LCDs. A linear current regulator with matched internal resistors and an adaptive phase-shifted PWM dimming controller are proposed to promote LED current uniformity and to enhance the immunity from flicker and audible noise due to LED open or short fault, respectively. The double feedback loop control method is used to improve the power efficiency and transient characteristic of the boost converter.

The proposed LED backlight driver IC was fabricated using a  $0.35\ \mu\text{m}$  BCD technology. The fabricated chip consists of six current regulators, an adaptive phase-shifted PWM dimming controller, and a double feedback loop control boost converter, and drives six LED strings. It was verified that the maximum power efficiency of the boost converter is 90%, and that 97% LED current uniformity is achieved. The proposed LED backlight driver IC operates up to 39 kHz, with an 8-bit dimming resolution. Further, there is no flicker and audible noise when an LED fault occurs. Therefore, the proposed LED backlight driver IC meets the requirements for an LED backlight driver IC for medium-sized LCDs, and was successfully developed. Further research will be conducted on the enhancement of the dimming resolution for medical and military applications, and on the improvement of the power efficiency at light-load conditions, for an ultra-power-efficient LED backlight system.

#### Acknowledgement

This work was supported by R&D Program of the Ministry of Knowledge Economy [K100411351, Development of Multifunctional Power Management IC for Smart Mobile Devices].

#### References

- [1] A. Peker, A. Ferentz, D. Korcharz, R. Levy, R. Blaut, and T. Langer, presented at the Society Information Display, Los Angeles, California, USA, 2008.
- [2] C.-Y. Hsieh, S.-J. Wang, Y.-H. Lee, K.-H. Chen, and M.-T. Ho, presented at the Society Information Display, Los Angeles, California, USA, 2008.
- [3] M. Doshi and R. Zane, presented at the Applied Power Electronics Conference and Exposition, Anaheim, California, USA, 2007.
- [4] S.-Y. Tseng, S.-C. Lin, and H.-C. Lin, presented at the Applied Power Electronics Conference and Exposition, Austin, Texas, USA, 2008.

- [5] L. Burgyan and F. Prinz, US Patent No. 6,690,146 (20 February 2004).
- [6] Y. Hu and M.M. Jovanovic, *IEEE Trans. Power Electron.* **23**, 3116 (2008).
- [7] T.-J. Liao and C.-L. Chen, presented at the IEEE International Conference on Sustainable Energy Technologies, Singapore, 2008.
- [8] S.-I. Hong, J.-W. Han, D.-H. Kim, and O.-K. Kwon, presented at the IEEE International Conference Solid-State Circuits, San Francisco, California, USA, 2010.
- [9] R.W. Erickson and D. Maksimovic, *Fundamentals of Power Electronics* (Kluwer, Boston, 2001), p. 439.
- [10] M. Nishikawa, Y. Ishizuka, H. Matsuo, and K. Shigematsu, presented at the International Telecommunications Energy Conference, Providence, Rhode Island, USA, 2006.
- [11] MAXIM/Dallas Semiconductor, <http://datasheets.maximic.com/en/ds/MAX17061.pdf>, 2008.
- [12] TEXAS INSTRUMENTS, <http://focus.ti.com/lit/ds/symlink/tps61182.pdf>, 2009.
- [13] INTERSIL, <http://www.intersil.com/data/fn/fn6434.pdf>, 2008.