

Chemiluminescence Determination of Balofloxacin Based on Europium (III)-Sensitized $\text{KBrO}_3\text{-Na}_2\text{S}_2\text{O}_4$ Reaction in Micellar Medium

Fang Zhao,* Yu Qi, and Wei Xiong

*School of Chemistry and Chemical Engineering, Shihezi University; Xinjiang Bintuan Key lab of Chemical Engineering for Green Process, Shihezi, Xinjiang 832003, China. *E-mail: nlz837037@163.com*
Received October 9, 2011, Accepted November 20, 2011

A novel chemiluminescence (CL) flow injection method for the determination of balofloxacin is described. The method is based on the weak CL signal arising from the reaction of KBrO_3 with $\text{Na}_2\text{S}_2\text{O}_4$ in acidic medium being significantly enhanced by balofloxacin in the presence of europium (III) ion and sodium dodecyl benzene sulfonate (SDBS). The experimental conditions that affected CL intensity were carefully optimized and the CL reaction mechanism was briefly discussed. Under the optimum conditions, the relative CL intensity was proportional to the concentration of balofloxacin in the range of 7.0×10^{-11} to 3.0×10^{-7} g mL^{-1} . The detection limit was 2.7×10^{-11} g mL^{-1} and the relative standard deviation was 2.1% for 7.0×10^{-10} g mL^{-1} balofloxacin ($n = 13$). The proposed method was successfully applied to the determination of balofloxacin in pharmaceutical formulations and biological fluids.

Key Words : Chemiluminescence, $\text{KBrO}_3\text{-Na}_2\text{S}_2\text{O}_4$ reaction, Balofloxacin, Europium (III), Sodium dodecyl benzene sulfonate

Introduction

Balofloxacin (BLFX), chemically named 1-cyclopropyl-6-fluoro-1,4-dihydro-8-methoxy-7-(3-methylamino-piperidin-1-yl)-4-oxoquinoline-3-carboxylic acid, is the fourth generation of a new class of synthetic antibacterial fluoroquinolone agents. It has a broad antibacterial spectrum, ranging from gram-positive bacteria to gram-negative bacteria. BLFX exhibited excellent antibacterial activity against gram-positive bacteria such as multiple-drug-resistant staphylococci and pneumococci.¹⁻³ The methoxy group at the 8-position reduces photoallergic responses.^{4,5} Like other new fluoroquinolones, the bactericidal action of BLFX results from inhibition of the enzymes topoisomerase (II) (DNA gyrase) and topoisomerase (IV).⁶ It was largely excreted *via* urine as the unchanged chemical constitution.⁷

Various methods have been reported in the literature for the analysis of BLFX, based on high performance liquid chromatography with spectrofluorimetric detection (HPLC-FLD),^{8,9} UV spectrophotometric detection,^{10,11} HPLC-electrospray ionization-mass spectrometry (HPLC-ESI-MS),¹² spectrophotometry,¹³ and fluorospectrophotometry.^{14,15} Although these analytical techniques have been successfully applied to analysis of BLFX in pharmaceutical and biological samples, these assay methodologies often suffer from disadvantages of low sensitivity, complicated pretreatment, time consuming, and expensive instrumentation. Analytical procedures applying CL coupled with flow-injection analysis show the advantages of excellent sensitivity, wide linear dynamic range, good reproducibility, and inexpensive apparatus, so this technique has been extensively used in many fields. Recently, lanthanide-sensitized CL is very attractive, because the intermolecular energy transfers between

the absorbing ligand and the lanthanide ion results in the emission of a strong narrow-band luminescence with a large Stokes shift and long luminescence lifetime. The combination of the advantages of the CL method with the use of the lanthanide ions as luminescence probes offers new possibilities for sensitive determination of pharmaceutical and biologically important compounds. However, the lanthanide-sensitized CL system were mainly restricted to the CL reaction with KMnO_4 or Ce (IV) as oxidant.¹⁶⁻¹⁹

Bromate is an excellent oxidizing reagent for CL reactions because colorless KBrO_3 is not only absent of an absorption band in the visible range compared with other color inorganic oxidants (such as MnO_4^- , Ce^{4+} , $\text{Fe}(\text{CN})_6^{3-}$) commonly used in CL procedures, but is also more stable than H_2O_2 and NBS. However, to the best of our knowledge, only three CL systems of $\text{BrO}_3^- \text{-SO}_3^{2-}$, $\text{BrO}_3^- \text{-Rhodamine 6G}$, $\text{BrO}_3^- \text{-quinine}$ which used KBrO_3 as oxidant has been reported.²⁰

Reviewing the literature indicated that no CL method was reported for the determination of BLFX. In the present work, it was found that KBrO_3 can directly oxidize $\text{Na}_2\text{S}_2\text{O}_4$ in a phosphoric acid medium to produce weak CL, and that the formation of BLFX-Eu(III) complex and SDBS micelles can significantly enhance weak CL emission. Based on this phenomenon, a novel CL system of $\text{KBrO}_3\text{-Na}_2\text{S}_2\text{O}_4$ was proposed. In order to validate the applicability of the present CL system in real samples, it was applied to determine BLFX in pharmaceutical samples and human urine/serum samples with satisfactory result.

Experimental

Reagents and Chemicals. All chemicals were of analytical reagent grade and doubly distilled water was used

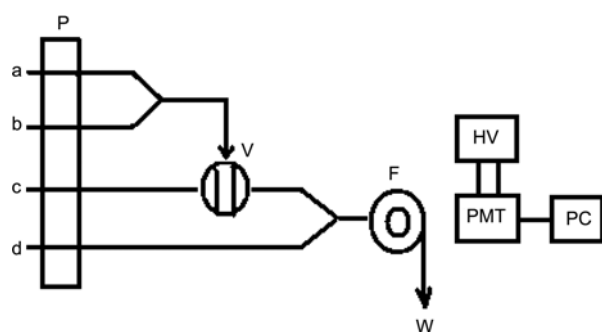

Figure 1. Schematic diagram of the flow-injection CL manifold employed for the determination of BLFX. P: peristaltic pump; V: injection valve; F: flow cell; PMT: photomultiplier tube; HV: high voltage; PC: computer; W: waste solution; a: BLFX solution; b: Eu (III) solution; c: $\text{Na}_2\text{S}_2\text{O}_4$ + SDBS solution; d: KBrO_3 solution.

throughout. Stock standard solution ($1.0 \times 10^{-3} \text{ g mL}^{-1}$) of BLFX was prepared by dissolving appropriate amount of BLFX (Sigma) in 0.005 mol L^{-1} NaOH. This solution was stored at 4°C and protected from light. Working standard solutions were freshly prepared by making appropriate dilutions of the stock standard solution with water. A stock standard solution of europium (III) ions ($2.0 \times 10^{-2} \text{ mol L}^{-1}$) was prepared by dissolving $0.352 \text{ g Eu}_2\text{O}_3$ (General Research Institute for Nonferrous Metals, China) in 1:1 HCl, evaporating the solution to be almost dry on a water bath, then diluting it to 100 mL with water. KBrO_3 stock solution (0.1 mol L^{-1}) was prepared by dissolving the required amount of KBrO_3 (Beijing Chemical Reagent Plant, China) in 0.07 mol L^{-1} H_3PO_4 . The $1.0 \times 10^{-3} \text{ mol L}^{-1}$ $\text{Na}_2\text{S}_2\text{O}_4$ and SDBS solutions were freshly prepared by dissolving each reagent in water.

Apparatus. An IFFM-E flow injection CL analyzer (Xi'an Remex Electronic Instrument High-Tech Ltd, China) was equipped with an automatic injection system and a detection system. A schematic diagram of the flow injection CL system is shown in Figure 1. All components were connected with PTFE tubing (0.8 mm i.d.). A peristaltic pump was used to deliver all flow streams, each at a flow rate of 3.0 mL min^{-1} . Injection was operated by means of a six-way valve equipped up with a $100 \mu\text{L}$ sample loop. The flow cell was a coil of glass tube that was positioned in front of the detection window of the photomultiplier tube (PMT). The CL signal was obtained using a BPCL ultra-weak luminescence analyzer (Institute of Biophysics Academia Sinica, China).

Procedure. As shown in Figure 1, The mixture of Eu (III) and BLFX sample solution/standard solution was injected into the mixed carrier stream of $\text{Na}_2\text{S}_2\text{O}_4$ and SDBS by the six-way injection valve, and then was merged with KBrO_3 solution *via* a Y-piece, to produce CL signal. The concentration of BLFX was quantified by the relative CL intensity.

Results and Discussion

CL Kinetic Curves of the System. The kinetic curve of CL reaction in the absence and presence of SDBS were

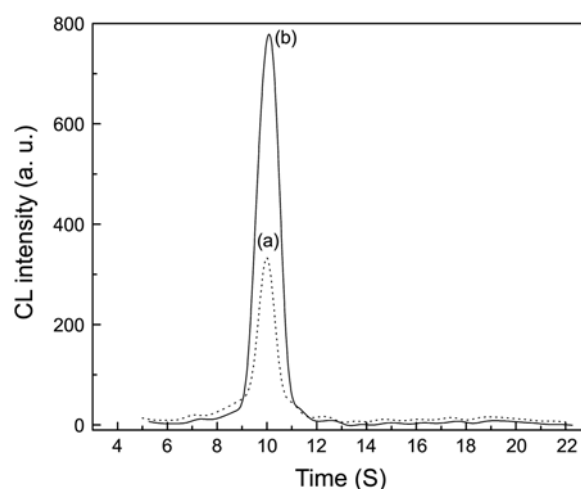

Figure 2. Kinetic curve of the CL reaction. (a): KBrO_3 - $\text{Na}_2\text{S}_2\text{O}_4$ -Eu (III)-BLFX; (b): KBrO_3 - $\text{Na}_2\text{S}_2\text{O}_4$ -Eu (III)-BLFX-SDBS. Conditions, KBrO_3 : $3.0 \times 10^{-3} \text{ mol L}^{-1}$; $\text{Na}_2\text{S}_2\text{O}_4$: $5.0 \times 10^{-4} \text{ mol L}^{-1}$; Eu (III): $7.0 \times 10^{-5} \text{ mol L}^{-1}$; BLFX: $3.0 \times 10^{-9} \text{ g mL}^{-1}$; H_3PO_4 : 0.07 mol L^{-1} ; SDBS: $3.0 \times 10^{-3} \text{ mol L}^{-1}$.

investigated using the batch method. Figure 2(b) demonstrates that the CL reaction was so rapid that the CL intensity reached a maximum value within 2 s after the addition of BLFX. Compared with that without SDBS (Figure 2(a)), the CL intensity increased significantly. This kinetic curve indicated the CL system is very suitable for the analysis of BLFX.

Effect of Acid Type and Concentration. Because KBrO_3 only has a high redox potential in acidic media, an acidic media was used for the CL reaction. The nature and concentration of the acid used in the reaction have very significant influences on the CL intensity. Several acids, including HCl, H_2SO_4 , HNO_3 , and H_3PO_4 were added to the KBrO_3 solution in order to examine the influence on the CL intensity. It was found that the stronger CL signal and weaker background were obtained from H_3PO_4 -treated KBrO_3 solution. The concentration of H_3PO_4 in KBrO_3 solution was subsequently examined in the range of 1.0×10^{-3} to 3.0 mol L^{-1} (Figure S1, Supplementary Materials). The maximum CL intensity was obtained at 0.07 mol L^{-1} H_3PO_4 , which was therefore employed for subsequent experiments.

Effect of KBrO_3 Concentration. The effect of KBrO_3 concentration on the CL signal was checked in the range of 1.0×10^{-5} to $1.0 \times 10^{-2} \text{ mol L}^{-1}$ (Figure S2, Supplementary Materials). It was observed that the CL intensity rapidly increased with increasing in KBrO_3 concentration up to $3.0 \times 10^{-3} \text{ mol L}^{-1}$, and thereafter decreased with the increase of concentration. Lower concentration did not react adequately with $\text{Na}_2\text{S}_2\text{O}_4$, while too high concentration would result in separating out of KBrO_3 solid in the microheterogeneous solution and the waste of reagent. Thus, $3.0 \times 10^{-3} \text{ mol L}^{-1}$ KBrO_3 was employed for whole experiment.

Effect of $\text{Na}_2\text{S}_2\text{O}_4$ Concentration. The effect of $\text{Na}_2\text{S}_2\text{O}_4$ concentration on the CL signal was tested over the range of 5.0×10^{-5} to $1.0 \times 10^{-2} \text{ mol L}^{-1}$ (Figure S3, Supplementary

Materials). The maximum CL intensity was obtained at $5.0 \times 10^{-4} \text{ mol L}^{-1} \text{ Na}_2\text{S}_2\text{O}_4$, with a slowly decrease when using higher concentration, so $5.0 \times 10^{-4} \text{ mol L}^{-1} \text{ Na}_2\text{S}_2\text{O}_4$ was selected as optimum value for further measurement.

Effect of Eu (III) Concentration. The effect of Eu (III) ions concentration on the CL intensity was studied over the range from 1.0×10^{-6} to $1.0 \times 10^{-3} \text{ mol L}^{-1}$ (Figure S4, Supplementary Materials). With increasing Eu (III) ions concentration from 1.0×10^{-6} to $7.0 \times 10^{-5} \text{ mol L}^{-1}$, the relative CL intensity first increased rapidly, but then decreased at Eu (III) ions concentration over $7.0 \times 10^{-5} \text{ mol L}^{-1}$. Hence, a $7.0 \times 10^{-5} \text{ mol L}^{-1}$ Eu (III) ions concentration was chosen.

Effect of Surfactant on the CL Intensity. Surfactants are often played a vital role to boost up the emission intensity of CL reaction. Various surfactants, sodium dodecylsulfate (SDS), sodium dodecylbenzenesulfonate (SDBS), cetyltrimethylammonium bromide (CTAB), Triton-100, β -cyclodextrin, were used to examine the effect of the sensitization behavior on the CL system. Results showed that the greatest CL signal was appeared by the use of SDBS as micellar medium. The effect of SDBS concentration within the range 1.0×10^{-4} to 0.1 mol L^{-1} on the CL intensity was also investigated (Figure S5, Supplementary Materials). The results showed that CL intensity reached a maximum value at $3.0 \times 10^{-3} \text{ mol L}^{-1}$. Hence, $3.0 \times 10^{-3} \text{ mol L}^{-1}$ SDBS was used for the whole experiment.

Effect of the Flow Rate. The effect of flow rate on the CL reaction was studied in the range of 1.0 - 5.0 mL min^{-1} . The CL intensity continued to increase with increasing in flow rate (Figure S6, Supplementary Materials). Finally a flow rate of 3.0 mL min^{-1} was selected by considering reagents consumption and precision.

Analytical Performance. Under the optimum conditions described, the relative CL intensity of the system (ΔI) was linearly proportional to the concentration of BLFX (C) in the range from 7.0×10^{-11} to $3.0 \times 10^{-7} \text{ g mL}^{-1}$. The regression equation was $\Delta I = 9.17 + 5.42C$ ($C: 10^{-10} \text{ g mL}^{-1}$) with a correlation coefficient of 0.9983 during $c = 7.0 \times 10^{-11}$ - $7.0 \times 10^{-9} \text{ g mL}^{-1}$ and $\Delta I = -89.53 + 217.2 C$ ($C: 10^{-8} \text{ g mL}^{-1}$) with a correlation coefficient of 0.9987 during $c = 7.0 \times 10^{-9}$ - $3.0 \times 10^{-7} \text{ g mL}^{-1}$. The detection limit for BLFX based the calculation from the standard deviation of the blank (the reagent blank without BLFX, $n = 20$) (3σ) was $2.7 \times 10^{-11} \text{ g mL}^{-1}$. The relative standard deviation (RSD) was 2.1% for

13 repeated determinations of $7.0 \times 10^{-10} \text{ g mL}^{-1}$ BLFX. In comparison with other methods reported, as shown in Table 1, the method proposed in this paper offers higher sensitivity and a wide linear range.

Interference Studies. The effects of foreign ionic species such as common metallic ions and coexisting compounds, which are frequently present in drugs and biological fluids, were investigated to assess the analytical potentiality of the method. To $1.0 \times 10^{-9} \text{ g mL}^{-1}$ BLFX in the optimum conditions, the tolerable concentration ratios for interference at the 5% level were over 1000-folded for K^+ , Na^+ , NH_4^+ , Ca^{2+} , Mg^{2+} , Ni^{2+} , NO_3^- , Cl^- , starch, lactose, glucose; 500-folded for SO_4^{2-} , Zn^{2+} , metoprolol, tartrate; 100-folded for Al^{3+} , Cr^{3+} , Co^{2+} , dextrin, oxalate; 10-folded for Mn^{2+} , Fe^{3+} , Fe^{2+} , Cu^{2+} , β -cyclodextrin, ascorbic acid and uric acid.

Analytical Applications. Twenty tablets obtained from the local market were weighed to obtain the average weight. They were finely powdered and homogenized. A portion of the powder known to contain an equivalent amount of one tablet was accurately weighed and dissolved in $0.005 \text{ mol L}^{-1} \text{ NaOH}$. The mixture was stood for 15 min and filtered. The filtrate was appropriately diluted with water so that the final concentration analyzed was within the working range. The components of 20 capsules were emptied mixed and treated in the same manner as described above for the tablets. The proposed method was applied to the determination of BLFX in two pharmaceutical preparations. The results obtained are summarized in Table 2.

Serum samples were obtained from the local hospital. A known amount of BLFX standard solution and 0.2 mL of serum samples were transferred into a centrifuge tube and mixed for 2 min. The potential effect produced by proteins and reducing substances was eliminated with 2.0 mL of $0.1 \text{ mol L}^{-1} \text{ Ba(OH)}_2$ and 1.8 mL of $0.10 \text{ mol L}^{-1} \text{ ZnSO}_4$ accord-

Table 2. Results for the Determination of BLFX in pharmaceutical preparations

Sample	Claimed (mg)	Proposed method (mg)	RSD ^a (%) (n = 7)	UV-vis method ¹³ (mg)	RSD ^a (%) (n = 5)
Tablet	100	99.3	1.9	100.4	1.0
Capsule	100	101.3	2.1	99.6	1.2

^aRelative standard deviation

Table 1. Figures of merit for determination of BLFX

Method	Detection limit	Linear range	Matrix	Reference
HPLC-FLD	$10 \mu\text{g L}^{-1}$	50 - $4000 \mu\text{g L}^{-1}$	Human plasma	9
HPLC-UV	47 ng mL^{-1} ^a	47 - 6000 ng mL^{-1}	Human plasma	11
HPLC-ESI-MS	$0.02 \mu\text{g mL}^{-1}$	0.03 - $3 \mu\text{g mL}^{-1}$	Human plasma	12
Spectrophotometry	$0.074 \mu\text{g mL}^{-1}$	2 - $20 \mu\text{g mL}^{-1}$	Pharmaceutical preparations	13
Spectrofluorimetry	$4 \mu\text{g mL}^{-1}$	0.04 - $2 \mu\text{g mL}^{-1}$	Capsules	14
Spectrofluorimetry	$2.0 \times 10^{-9} \text{ mol L}^{-1}$	1.0×10^{-8} - $8.0 \times 10^{-7} \text{ mol L}^{-1}$	Pharmaceuticals, human urine/serum	15
FI-CL	$2.7 \times 10^{-11} \text{ g mL}^{-1}$	7.0×10^{-11} - $3.0 \times 10^{-7} \text{ g mL}^{-1}$	Pharmaceuticals, human urine/serum	Proposed method

^aLimit of quantification

Table 3. Results for the determination of BLFX in serum samples (n = 5)

Sample	Added ($\times 10^{-9}$ $\mu\text{g mL}^{-1}$)	Found ($\times 10^{-9}$ $\mu\text{g mL}^{-1}$)	RSD (%)	Recovery (%)
1	1.0	0.989	2.1	98.9
2	9.0	9.09	1.9	101
3	30.0	29.93	1.7	99.8

Table 4. Results for the determination of BLFX in urine samples ($\mu\text{g mL}^{-1}$, n = 5)

Amount in sample	Added ($\times 10^{-9}$)	Found ($\times 10^{-9}$) \pm RSD (%)	Recovery (%)
	3.0	2.91 ± 2.3	97
23.7 ± 1.7	10.0	10.3 ± 1.9	101.3
	30.0	29.67 ± 1.7	98.9

ing to the reported method.²¹ The solution was then homogenized and centrifuged for 15 min at 4000 rpm. A healthy volunteer was administered 100 mg BLFX and then after 12 h the real urine samples were collected. No further pretreatment was required for urine samples except proper dilution. Further dilutions with water were made in order to ensure that the concentration of the analyte in the sample solutions fell within the linear range of the method. The recoveries of serum and urine samples containing BLFX were determined by the standard addition method. The results obtained are listed in Table 3 and 4.

Possible CL Mechanism. The oxidation of SO_3^{2-} in acid solution is a well known CL reaction and the analytical properties of the reaction have been thoroughly studied with Ce (IV) or MnO_4^- as the oxidants. The CL emission has been attributed to the formation of excited SO_2^* species which radiate during de-excitation.²² In this CL system, $\text{S}_2\text{O}_4^{2-}$ is not stable in acidic medium and decomposed to HSO_3^- and $\text{S}_2\text{O}_3^{2-}$. BrO_3^- oxidizes HSO_3^- to HSO_3^\cdot , and then two HSO_3^\cdot radicals react to produce $\text{S}_2\text{O}_6^{2-}$. $\text{S}_2\text{O}_6^{2-}$ gives the excited intermediate product SO_2^* , which emits radiation in the spectral region 260–480 nm.²³ However, the CL intensity is very weak because of the low luminescence efficiency of SO_2^* . Emission of Eu (III) itself is also very weak in aqueous solution. Eu (III) or BLFX was added to the CL system of KBrO_3 - $\text{Na}_2\text{S}_2\text{O}_4$, respectively, and no notable increase in the CL signal could be observed. But the CL signal was remarkably enhanced by the presence of Eu (III) and BLFX. We used the molar ratio method to examine the composition of the Eu (III)-BLFX. The molar ratio of Eu (III) to BLFX is 1:2.²⁴

In order to gain a better understanding of the nature of the CL enhancement, the fluorescence spectra for the solution of BLFX, BLFX-Eu (III) and the mixture of BLFX-Eu (III)-SDBS were in the range of 300–900 nm, using a F-2500 fluorescence spectrometer (Figure 3). The native fluorescence emission of BLFX in acidic medium gives a broad peak at 493 nm. The emission spectrum of BLFX-Eu (III) shows a weak peak at 617 nm. When the anionic surfactants,

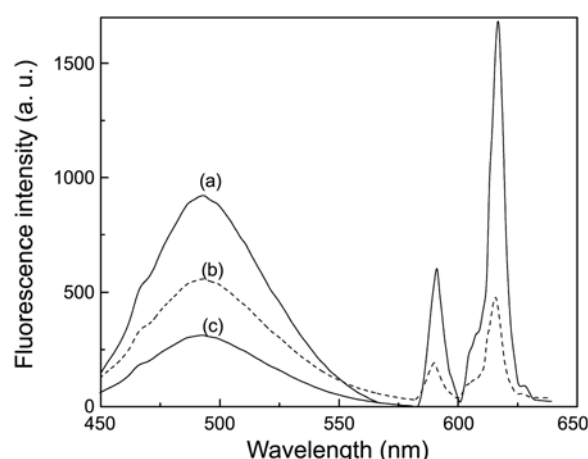
**Figure 3.** The fluorescence spectra. (a): BLFX; (b): BLFX- Eu (III); (c): BLFX- Eu (III)-SDBS. Conditions, BLFX: 3.0×10^{-7} g mL^{-1} ; Eu (III): 7.0×10^{-5} mol L^{-1} ; SDBS: 3.0×10^{-3} mol L^{-1} ; $\lambda_{\text{ex}} = 390$ nm.

SDBS, was added, the emission spectrum of BLFX-Eu (III)-SDBS shows two emission peaks at 593 nm and 617 nm, corresponding to the transition of the Eu (III) $^5\text{D}_0$ - $^7\text{F}_1$ and $^5\text{D}_0$ - $^7\text{F}_2$, respectively.²⁵ The SDBS micelles were formed when SDBS was added to the CL reaction system. With the addition of $(\text{BLFX-Eu})^{3+}$, as a result of existence in the form of cations in the aqueous solution, the sensitized $(\text{BLFX-Eu})^{3+}$ complex should be more easily aggregated around the micelle of anionic surfactant SDBS. The emitter species SO_2^* was easier to be dissolved in hydrophobic medium than in water,²⁶ resulting in an occurrence of more efficient energy transfer from SO_2^* to $(\text{BLFX-Eu})^{3+}$. Moreover, the cage structure created by micelles can protect the excited species from the collisional quenching of light emission, increase the excited state lifetimes and decrease the rate of radiationless energy transfer processes, making CL signal of the present system increased.²⁷

The CL spectrum of the KBrO_3 - $\text{Na}_2\text{S}_2\text{O}_4$ -BLFX-Eu (III)

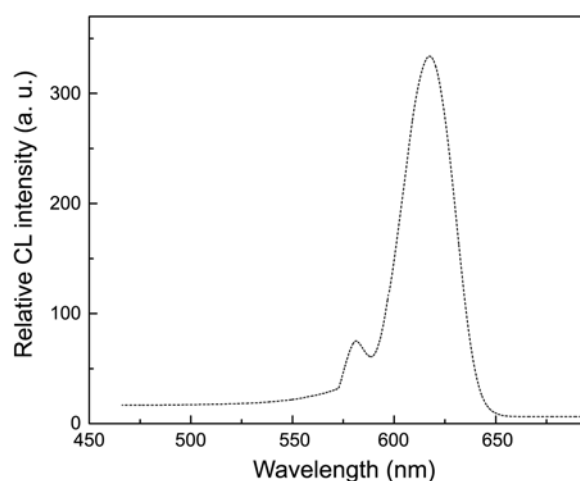
**Figure 4.** CL spectrum of KBrO_3 - $\text{Na}_2\text{S}_2\text{O}_4$ -Eu (III)-BLFX reaction. Conditions, KBrO_3 : 3.0×10^{-3} mol L^{-1} ; $\text{Na}_2\text{S}_2\text{O}_4$: 5.0×10^{-4} mol L^{-1} ; Eu (III): 7.0×10^{-5} mol L^{-1} ; BLFX: 7.0×10^{-9} g mL^{-1} ; H_3PO_4 : 0.07 mol L^{-1} .

reaction is shown in Figure 4. The emission peaks of the system are located at 593 nm and 617 nm, which are the characteristic fluorescence peaks of Eu (III) ions, indicating clearly that the electronically excited Eu (III) ions are the emitter.

Based on the illustration above, the possible CL mechanism of the reaction may be attributed to the following reactions:

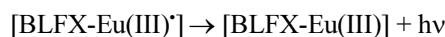
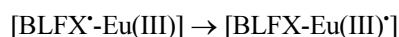
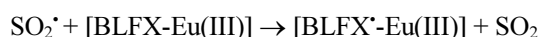
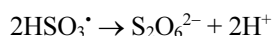
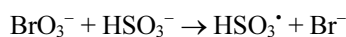
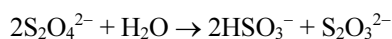

Conclusions

A novel flow injection CL analysis method based on the $\text{KBrO}_3\text{-Na}_2\text{S}_2\text{O}_4\text{-Eu(III)-BLFX-SDBS}$ CL system has been developed for the determination of BLFX. Compared to the present method (Table 1) for the determination of BLFX, the proposed method displays satisfactory advantages in terms of sensitivity, simplicity and accuracy. It has been successfully applied to determine BLFX in pharmaceutical preparations, human serum and urine samples. The possible CL reaction mechanism was also discussed briefly.

Acknowledgments. The authors gratefully acknowledge financial support from Shihezi University.

References

- Alksne, L. *Curr. Opin. Investig. Drugs* **2003**, *4*, 224.
- Marutani, K.; Matsumoto, M.; Otabe, Y.; Nagamuta, M.; Tanaka, K.; Miyoshi, A.; Hasegawa, T.; Nagano, H.; Matsubara, S.; Kamide, R. *Antimicrob. Agents Chemother.* **1993**, *37*, 2217.
- Ito, T.; Otsuki, M.; Nishino, T. *Antimicrob. Agents Chemother.* **1992**, *36*, 1708.
- Gohara, Y.; Arai, S.; Akashi, A.; Kuwano, K.; Tseng, C. C.; Matsubara, S.; Matumoto, M.; Furudera, T. *Antimicrob. Agents Chemother.* **1993**, *37*, 1826.
- Matsumoto, M.; Kojima, K.; Nagano, H.; Matsubara, S.; Yokota, T. *Antimicrob. Agents Chemother.* **1992**, *36*, 1715.
- Ito, T.; Kojima, K.; Koizumi, K.; Nagano, H.; Nishino, T. *Biol. Pharm. Bull.* **1994**, *17*, 927.
- Kozawa, O.; Uematsu, T.; Matsuno, H.; Niwa, M.; Nagashima, S.; Kanamaru, M. *Antimicrob. Agents Chemother.* **1996**, *40*, 2824.
- Nakashima, M.; Uematsu, T.; Fukuchi, M.; Nakano, M.; Kosuge, K. *Jpn. J. Chemother.* **1995**, *43*, 115.
- Zhang, J. W.; Guo, T.; Sui, Y.; Yan, M.; Zhao, L. S. *Chi. J. Clinical Pharmacy* **2007**, *16*, 296.
- Nakagawa, T.; Ishigai, M.; Hiramatsu, Y.; Kinoshita, H.; Ishitani, Y.; Ohkubo, K.; Okazaki, A. *Arznei.-Forschung* **1995**, *45*, 716.
- Liu, X.; Zhou, G.; Tan, Z. R.; Ouyang, D. S. *Central South Pharmacy* **2006**, *4*, 270.
- Bian, Z. W.; Tian, Y.; Zhang, Z. J.; Xu, F. G.; Li, J. H.; Cao, X. M. *J. Chromatogr. B* **2007**, *850*, 68.
- Yu, C. Y.; Wang, H. M.; Guo, Y.; Cao, X.; He, X. Z.; Cheng, S. X. *J. Wuhan Bioengineering Institute* **2007**, *3*, 125.
- Qi, X. J.; Wang, J. X.; Liu, Z. R. *Chi. J. Anal. Chem.* **2006**, *34*, 1047.
- Wang, L.; Guo, C.; Chu, Z.; Jiang, W. *J. Lumin.* **2009**, *129*, 90.
- Wang, X.; Zhao, H. C.; Nie, L. H.; Jin, L. P.; Zhang, Z. L. *Anal. Chim. Acta* **2001**, *445*, 169.
- Yi, L.; Zhao, H. C.; Chen, S. L.; Jin, L. P.; Zheng, D. D.; Wu, Z. L. *Talanta* **2003**, *61*, 403.
- Ocana, J. A.; Callejon, M.; Barragan, F. J.; Rosa, F. D. L. *Anal. Chim. Acta* **2003**, *482*, 105.
- Ocana, J. A.; Barragan, F. J.; Callejon, M.; Rosa, F. D. L. *Mikrochim. Acta* **2004**, *144*, 207.
- Li, B. X.; Zhang, Z. J.; Liu, M. L.; Xu, C. L. *Anal. Bioanal. Chem.* **2003**, *377*, 1212.
- Li, B. X.; Zhang, Z. J.; Liu, M. L.; Xu, C. L. *Anal. Sci.* **2003**, *19*, 1643.
- Bostick, D. T.; Hercules, D. M. *Anal. Chem.* **1975**, *47*, 447.
- Kenner, R. D.; Ogryzlo, E. A. In *The Chemi-and Bioluminescence*; Burr, J. G., Ed.; Marcel Dekker: New York, 1985; p 139.
- Job, P. *Ann. Chim.* **1928**, *9*, 113.
- Molina, C.; Dahmouche, K.; Messaddeq, Y.; Ribeiro, S. T. L.; Silva, M. A. P.; Bermudez, V. D. Z. P.; Carlos, L. D. *J. Lumin.* **2003**, *104*, 93.
- Kato, M.; Yamada, M.; Suzuki, S. *Anal. Chem.* **1984**, *56*, 2629.
- Paleos, C. M.; Vassilopoulos, G.; Nikokavouras, J. *J. Photochem.* **1982**, *18*, 327.