

논문 2012-49-12-2

# LTE-Advanced 시스템에서 릴레이 프로토콜을 적용한 지능형 AMC 기법의 설계 및 분석

( Design and Analysis of Intelligent AMC Scheme with Relay Protocols  
in LTE-Advanced System )

사란쉬 말리크\*, 김 보 라\*, 문 상 미\*, 김 대 진\*\*, 황 인 태\*\*

( Saransh Malik, Bora Kim, Sangmi Moon, Daejin Kim, and Intae Hwang )

## 요 약

본 논문에서는 AMC(Adaptive Modulation and Coding) 기법을 적용한 릴레이 프로토콜을 제안한다. AMC 기법은 다양한 변조와 코딩 기법을 통해, 통신 시스템의 전송률과 신뢰도를 향상시킬 수 있다. 본 논문에서는 AMC 기법을 적용한 릴레이 프로토콜의 성능을 분석하고, AMC 기법이 적용된 릴레이 프로토콜이 AMC 기법이 적용되지 않은 기존의 기법과 비교하여 낮은 SNR(Signal to Noise Ratio) 레벨에서 더 좋은 평균 전송률을 제공할 수 있음을 확인하였다. 비적응적 MCS(Modulation and Coding Scheme) 릴레이 프로토콜과 적응적 MCS 릴레이 프로토콜의 성능을 증명하기 위해 LTE-A(Long Term Evolution-Advanced) 파라미터와 함께 몬테카를로 시뮬레이션을 수행하였다. 모의실험 결과, 적응적 MCS가 적용된 시스템에서 AF(Amplify-and-Forward), DF(Decode-and-Forward) 및 DMF(DeModulate-and-Forward) 프로토콜 중 DMF 프로토콜이 낮은 SNR 값에서 가장 좋은 성능을 보이고, 더 좋은 평균 전송률을 제공하는 것을 확인하였다.

## Abstract

In this paper, we propose an Adaptive Modulation and Coding (AMC) scheme using relay protocols generally known as Relay Node (RN). The AMC scheme is used for improving the throughput and a reliability of a communication system, because of the nature of different modulation and coding schemes. We analyze the performance of relay protocols with the AMC scheme and observed that relay protocols with the AMC scheme is capable of providing better average throughput at a lower Signal to Noise Ratio (SNR) level as compared to the conventional scheme with no AMC. We perform Monte Carlo simulations with Long Term Evolution-Advanced (LTE-A) parameters to prove the performance comparison of adaptive Modulation and Coding Scheme (MCS) relay protocols with the non-adaptive MCS relay protocols. The simulation results of the proposed system with adaptive MCS prove that among the Amplify-and-Forward (AF), Decode-and-Forward (DF) and DeModulate-and-Forward (DMF), the DMF protocol performs best at a lower SNR value and also provides better average throughput.

**Keywords** : AF, DF, DMF, AMC, LTE-Advanced

\* 학생회원, \*\* 평생회원, 전남대학교 전자컴퓨터공학과

(School of Electronics & Computer Engineering Chonnam National University)

※ 본 연구는 지식경제부 및 정보통신산업진흥원의 대학 IT연구센터 지원사업의 연구결과로 수행되었음.  
(NIPA-2012-H0301-12-3005).

※ 이 논문은 2011년도 전남대학교 학술연구비 지원에 의하여 연구되었음.

접수일자: 2012년11월15일, 수정완료일: 2012년11월22일

## I. Introduction

In recent years, relaying technology in cellular systems has received significant interest. Relay based network architectures show promising interest in potential and practical applications as Long Term Evolution-Advanced (LTE-Advanced)<sup>[1-3]</sup>. Cooperative communications<sup>[1-3]</sup> can exploit the distributed spatial diversity in multiuser systems to combat the impairments of the wireless channels. This is particularly useful when each node can only be equipped with a single antenna. Without the channel feedback, the conventional cooperative protocols, such as Amplify-and-forward (AF), Decode-and-forward (DF), etc, can offer a diversity gain by allowing nodes a fair opportunity to transmit messages through their own channel<sup>[4-6]</sup>. On the other hand, if the Channel State Information (CSI) is available to the senders, the system can re-allocate the radio resource among the senders to improve the communication efficiency. Furthermore, all the nodes are allowed to adapt their data rates to match the channel conditions such that the throughput is maximized<sup>[7-8]</sup>. Motivated by this fact, we consider adaptive modulation for various protocol systems. Adaptive Modulation and Coding (AMC)<sup>[9-12]</sup> can provide high spectral efficiency, meanwhile the reliability of the data can be guaranteed, its adaptation features makes it attractive for further research in several areas, especially if a high data rate is among the expected results. Our proposal consists then, in the combination of MIMO and AMC schemes in one single system: Adaptive-MCS. The optimal selection of the coding rate, modulation and relay protocols scheme result is an improvement of the data rate and system reliability. The goal is to maximize the data throughput and system efficiency.

The rest of the paper is organized as follows, Section II describe the system model and adaptive MCS with Relay i.e. Section III explains the proposed criteria for adaptive MCS selection in the relay

system, Section IV presents the simulation results and analysis. Finally, conclusions are discussed in section V.

## II. System Model and Adaptive MCS with Relay

Assume that the channel gains are completely known at the transmitter and the receiver and remain unchanged during a packet transmission. In a block fading channel, it is feasible to implement a reverse link to send back channel information and the assumption is practical. At the relay node we process three protocol types AF, DF and the DMF protocol. The AF and DF protocols are considered as the conventional protocols in the fixed relay system which are already adapted by the LTE-A. We analyze the consistency and efficiency of the DMF protocol with MCS comparing their results with Conventional designed algorithms.

In figure 1, we describe the structure of the Adaptive-MCS system with RN operation. At the Evolved Node B (eNB), the data is coded, interleaved, modulated and then, transmitted through the channel. Once at the receiver the channel condition is estimated with a Signal-to-Noise-Ratio(SNR) criterion, this information is sent back to the transmitter, which decides what Modulation and Coding Scheme(MCS) level to use. The previous



그림 1. AMC 기반의 릴레이 시스템 모델  
 Fig. 1. System Model of relay with AMC based system.

channel condition parameters are stored in a buffer. When the signal arrived at the Relay Node (RN), we select the protocols for various scenarios by first analyzing the channel parameters given by the Channel Evaluator (CE) from the RN - UE link. As per the performance of CE, the suitable MCS level is chosen for the best average throughput performance. Choosing the MCS level means to select a specific code rate and modulation scheme according to the estimation of the channel conditions. Based on the idea of the pre-evaluated channel quality, we select the favorable relay protocol. This data is then sent to the User Equipment (UE). The UE also analyzes the CE and based on the channel condition between RN-UE links. If the channel condition is favorable, a high order of modulation and code rate are used. Otherwise, a low order of modulation and code rate are selected. With the appropriate MCS level, AMC can obtain both excellent throughput performance and quality for a specific channel condition.

### III. Proposed Criteria for the Adaptive MCS Selection and Protocol design

Adaptive Modulation and Coding is performed according to several SINR regions. Here, we first discuss the region boundary for the modulation regarding the modulation adaptation among various schemes of modulation as QPSK and 16-QAM with a code rate of 1/3 and 3/4. Let  $\gamma_{sr}$  and  $\gamma_{rd}$  denote the received SINR of the SR and RD link.  $P_{SR}$  and  $P_{RD}$  can be the error probability for the Source-Relay link and Relay-Destination link respectively. If the RN can obtain data correctly with the probability of  $(1-P_{SR})$  the final errors calculated from the detection of combined SD and RD link,  $P_{SD}$ , when the relay cannot acquire the data correctly at the SR link the probability is given by,  $P_{SR}$ . Thus, the total BER for this state is given by (1)

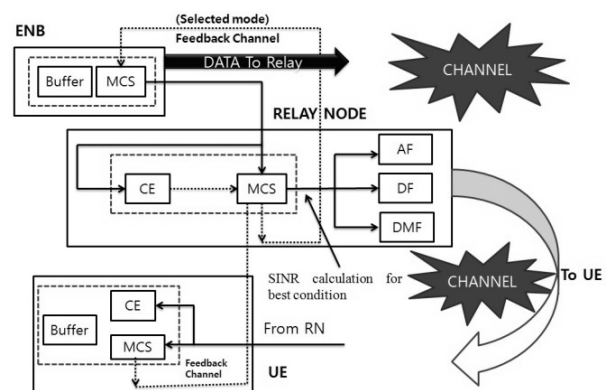
$$P_e = (1 - P_{SR})P_{SD} + P_{SR} \quad (1)$$

From [13], we know that BER of M-QAM modulation can be obtained as (3)

$$P = \alpha Q\sqrt{\beta\gamma} \quad (2)$$

Where,  $Q(x) = \frac{1}{\sqrt{2\pi}} \int_x^\infty e^{-\frac{u^2}{2}} du$ , where  $a$  and  $\beta$  are decided by the modulation scheme. But, the inversion of the above scheme is complex for inversion. So, to simplify the above design and performance analysis we model the expression, where  $n$  is the MCS level,

$$BER_n(\gamma) \cong \alpha_n \exp(-b_n \gamma) \quad (3)$$

Here, we analyze various characteristics of the scheme comprising the Adaptive-MCS with Relay.

#### 1. Pre-coding scheme

The pre-coding scheme is located at the eNB. It improves the system performance by using the estimated channel information calculated at the RN. There are several techniques used for pre-coding, such as Pre-Zero Forcing (ZF) and Pre-Minimum Mean Square Error (MMSE).

#### 2. Relay Protocols

The relay protocols considered in our research paper are AF, DF and DMF. We will now evaluate various relay protocols with AMC. Fig.2 shows the flowchart of the Relay scheme with AMC. Firstly, the Channel State Information (CSI) is calculated based on the link condition and estimation. Then each protocol is selected as per the situation since all protocols same amount of maximum throughput. Suppose, we select the DMF protocol. Afterwards, we check the given MCS level. In the MCS level, we then check the type of the code rate and modulation. When both are satisfied as defined by the condition. We again check the CSI for the next link of relay and the UE, as stored in the buffer at the relay node. Based on the estimation of the CSI, we make the



그림 2. AMC가 적용된 릴레이 기법의 흐름도  
Fig. 2. Flow Chart of AMC with Relay Scheme.

error check of the present CSI and previous CSI. If the state is true we can then calculate the final throughput estimate as per the given MCS level, otherwise we need to recheck the MCS level and append the new CSI value in the relay node. Then, we need to verify the MCS level for RN-UE link. Once the throughput is estimated, the new data frame, which is needed to be transmitted to the UE with lower error probability, needs to be verified. The dotted part in the flowchart shows the main performance area in the algorithm.

#### IV. Simulation Results

The simulation results are based on the link level Monte Carlo simulations. The system follows half duplex mode. Noise components are the same at all channel links but channel fading components increase and decrease based on the links as eNB-RN link and RN - UE link characteristics. Table 1 shows the simulation parameters are based on 3GPP LTE-Advanced 20 MHz Bandwidth.

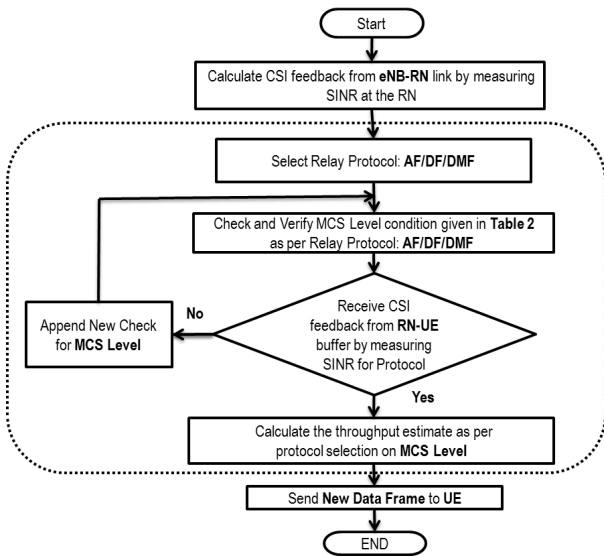
표 1. 모의실험 파라미터

Table 1. Simulation Parameters.

| Parameter                    | Value                           |
|------------------------------|---------------------------------|
| Bandwidth                    | 20 MHz                          |
| Subcarrier spacing           | 30.72 KHz                       |
| Sub frame Duration           | 1 ms                            |
| FFT Size                     | 2048                            |
| Subcarriers                  | 1200 + 1(DC sub carrier) = 1201 |
| No. of Sub-frame/PRB         | 12                              |
| CP size(samples)             | 256 (Extended CP)               |
| No. of OFDM Symbols/subframe | 12 (Extended CP)                |
| Channel                      | EPA, EVA, ETU                   |
| Modulation Scheme            | QPSK ,16 QAM                    |
| Noise                        | AWGN                            |
| Relay Node (RN)              | 1                               |
| Relaying Protocol            | AF, DF, DMF                     |

#### 1. FER, SER and BER Analysis of AF, DF and DMF

We will now discuss the error performance and analysis of all three protocols in order to clarify their behavior in our adaptive MCS relay system.

Fig. 3 presents the Frame Error rate (FER) performance for the 3 kinds of protocols. We can clearly observe that the performance of the DMF protocol shows a very high trade off compared to AF and DF protocols. The tradeoff between AF and DF at higher SNR shows a very little error performance advantage but on the other hand the DMF protocol shows explicit performance.



그림 3. AF, DF, DMF 프로토콜의 FER 결과  
Fig. 3. FER Result of AF, DF and DMF protocols.



그림 4. AF, DF, DMF 프로토콜의 SER 결과  
 Fig. 4. SER Result of AF, DF and DMF protocols.

Fig. 4 analyzes the Symbol Error Rate (SER) performance analysis of the AF, DF and DMF protocols. Compared to Fig. 2 the performance of AF, DF and DMF shows slight improvement performance. Fig. 3 examines the error probability based on each symbol transmission. Therefore, compared to the FER performance this figure demonstrates better results, as the error encountered in the symbol rate is much more reduced in comparison to the Frame error of each case.

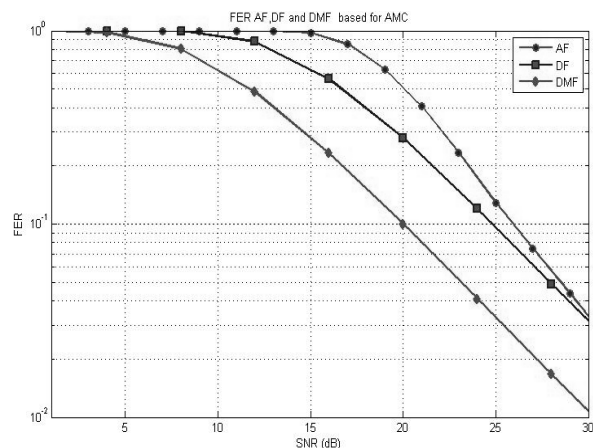
Fig. 5 shows the Bit Error Rate (BER) analysis which still shows better error performance for DMF compared to the AF and DF protocols. Here, we can observe that even at an improved error performance than compared to the FER or SER, AF and DF

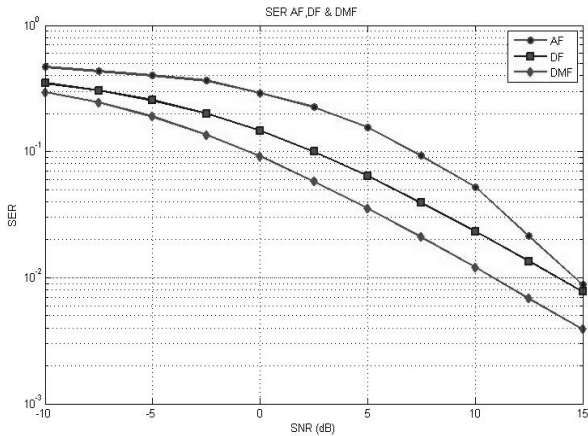

그림 5. AF, DF, DMF 프로토콜의 BER 결과  
 Fig. 5. BER Result of AF, DF and DMF protocols.

performance are very close at lower SNR values, whereas, the performance of DMF is still showing better results than the conventional protocols.

2. Non Adaptive MCS with AF, DF and DMF Relays

Table 2 shows the Non-Adaptive MCS level table with various MCS levels for AF, DF and DMF protocols based on the code rate as turbo coding with 1/3 and 3/4. The modulation schemes followed in this case are QPSK and 16-QAM. We observed various values of maximum throughputs in different code rates and modulation schemes.

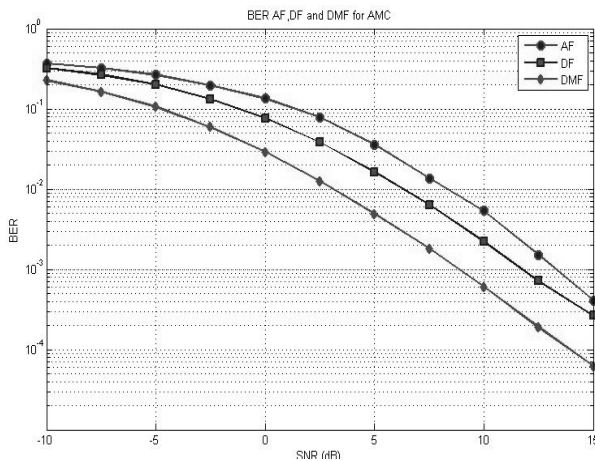
표 2. 비적응적 릴레이 MCS 표  
 Table 2. Non-Adaptive Relay MCS Table.

| MCS Level | Protocol | Code Rate | Modulation | Max. Throughput (Mbps) |
|-----------|----------|-----------|------------|------------------------|
| 1         | AF       | 1/3       | QPSK       | 14.4                   |
| 2         | AF       | 3/4       | QPSK       | 21.6                   |
| 3         | AF       | 1/3       | 16-QAM     | 28.8                   |
| 4         | AF       | 3/4       | 16-QAM     | 43.06                  |
| 5         | DF       | 1/3       | QPSK       | 14.4                   |
| 6         | DF       | 3/4       | QPSK       | 21.6                   |
| 7         | DF       | 1/3       | 16-QAM     | 28.8                   |
| 8         | DF       | 3/4       | 16-QAM     | 43.06                  |
| 9         | DMF      | 1/3       | QPSK       | 14.4                   |
| 10        | DMF      | 3/4       | QPSK       | 21.6                   |
| 11        | DMF      | 1/3       | 16-QAM     | 28.8                   |
| 12        | DMF      | 3/4       | 16-QAM     | 43.06                  |



그림 6. 비적응적 MCS AF 프로토콜의 전송률  
 Fig. 6. Throughput of Non Adaptive MCS AF Protocol.

The maximum throughput achieved by all the coding and modulation schemes is essentially different. The maximum throughput in all kinds of modulation and coding schemes is independent of the protocol use, as, we observe from Fig. 6, 7 and 8.

Fig. 6 shows the maximum throughput values at different code rates for the Non-Adaptive MCS AF protocol. The maximum throughput for code rate 1/2 with QPSK is observed, approximately 14.4 Mbps. As the code rate is increased in case of the same modulation, we can observe the increase in throughput at 21.6 Mbps. However, we have to compromise with SNR performance in this case. Similarly, with the increase in the modulation scheme we can observe the increase in throughput rate. Finally, we observed that higher the code rate and modulation, the higher the throughput but we have compromised the SNR performance which is gained at a very high SNR.

Fig. 7 shows the performance analysis for the Non-Adaptive MCS DF protocol. The maximum throughput is the same in case of AF and DF, as seen in Table 2. But, as we observe the values of SNR tradeoff we can see a considerable gain in the throughput case. We can observe that better decoding schemes improves the relay performance for relay code rate and modulation.

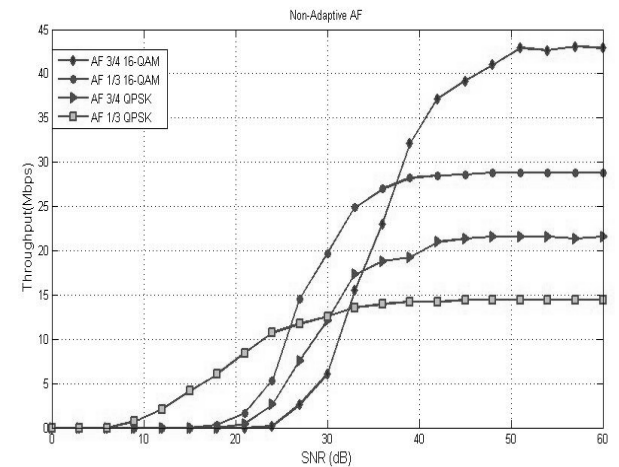
Fig. 8 shows the throughput of the Non-Adaptive



그림 7. 비적응적 MCS DF 프로토콜의 전송률  
Fig. 7. Throughput of Non Adaptive MCS DF Protocol.



그림 8. 비적응적 MCS DMF 프로토콜의 전송률  
Fig. 8. Throughput of Non Adaptive MCS DMF Protocol.

MCS DMF protocol, as case of AF and DF. We can understand that the code rate and modulation is the same for all protocols and so the maximum throughput as seen in the Table 2. If we look at the SNR Performance we can see the DMF protocol achieves higher throughput at lower SNR values.

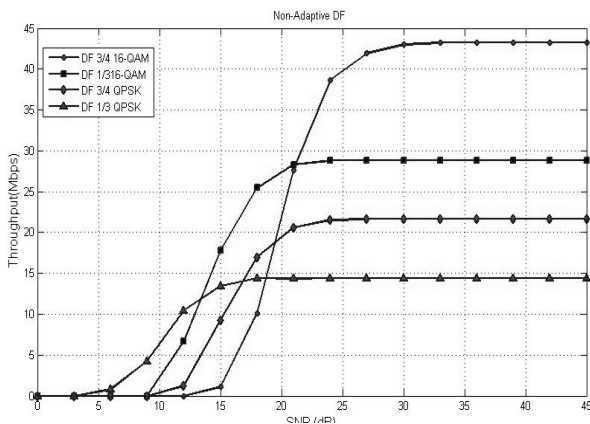
### 3. Adaptive Relay MCS with AF, DF and DMF Protocol

Table 3 shows the values for the Adaptive MCS level for the AF, DF and DMF Protocol for various values for code rate, modulation scheme. We made observations and analysis on the basis of SNR and Average Throughput.

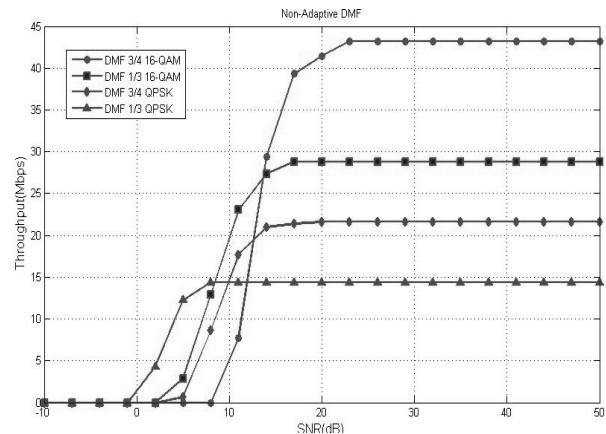
Fig. 9 shows the average throughput of the

표 3. 적응적 릴레이 MCS 표  
Table 3. Adaptive Relay MCS Table.

| MCS Level | Protocol | Code Rate | Modulation | SNR (dB) | Average Throughput (Mbps) |
|-----------|----------|-----------|------------|----------|---------------------------|
| 1         | AF       | 1/3       | QPSK       | 21       | 12.384                    |
| 2         | AF       | 1/3       | 16-QAM     | 36       | 26.976                    |
| 3         | AF       | 3/4       | 16-QAM     | 51       | 42.984                    |
| 4         | DF       | 1/3       | QPSK       | 12       | 10.468                    |
| 5         | DF       | 1/3       | 16-QAM     | 21       | 27.65                     |
| 6         | DF       | 3/4       | 16-QAM     | 30       | 42.984                    |
| 7         | DMF      | 1/3       | QPSK       | 8        | 14.4                      |
| 8         | DMF      | 1/3       | 16-QAM     | 14       | 27.36                     |
| 9         | DMF      | 3/4       | 16-QAM     | 23       | 42.984                    |



그림 9. 적응적 MCS AF 프로토콜의 평균 전송률  
 Fig. 9. Average Throughput of Adaptive MCS AF Protocol.

adaptive MCS AF protocol. We analyzed the new MCS level for specified code rate and modulation schemes for the AF case to achieve the average throughput and maximum throughput at the same time. The rapid increase in the throughput is calculated on the basis of maximum throughput achieved at lower code rates and lower modulation schemes. As analyzed points are shown in Fig. 8 the MCS level 1 on SNR at an average throughput of 21 dB was 12.364 Mbps. Then the MCS level 2 is switched to SNR 36 dB point and an average throughput of 26.976 Mbps. Following this, MCS level 3 is switched until the maximum throughput is

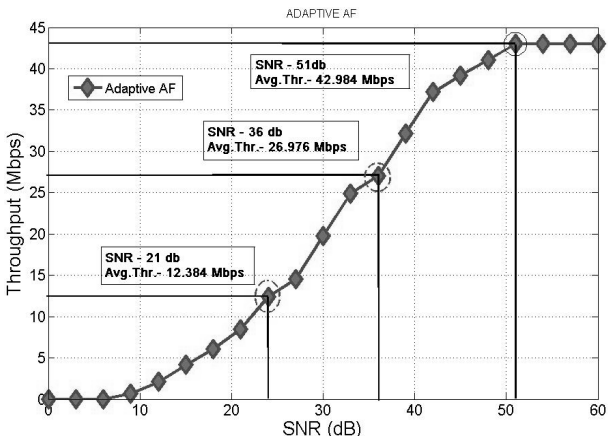

그림 10. 적응적 MCS DF 프로토콜의 평균 전송률  
 Fig. 10. Average Throughput of Adaptive MCS DF Protocol.

achieved at SNR 51 dB with an average throughput of 42.984 Mbps.

Fig. 10 shows the average throughput of the adaptive MCS DF protocol. The rapid gain in average throughput is observed similarly to the case of AF. As analyzed points are shown in Fig. 9 the MCS level 4 is selected first on SNR at 12 dB at an average throughput of 10.468 Mbps, then the MCS level 5 is switched to SNR 21 dB point and average throughput of 27.65 Mbps, and then to the MCS level 6 is switched till the maximum throughput is achieved at SNR 30 dB and an average throughput 42.984 Mbps. As far as the maximum throughput is considered it is same for all protocols.

Fig. 11 shows the average throughput of the adaptive MCS DMF protocol. The rapid gain in average throughput is observed best in the case of DMF. As analyzed points are shown in fig. 10 the MCS level 7 is selected first on SNR at 8 dB at an average throughput of 14.4 Mbps, then the MCS level 8 is switched to SNR 14 dB point and average throughput of 27.36 Mbps, and then the MCS level 9 is switched till the maximum throughput is achieved at SNR 23 dB and an average throughput of 42.984 Mbps. The maximum throughput is considered the same for all protocols but the SNR gain is best in the case regarding the DMF protocol.

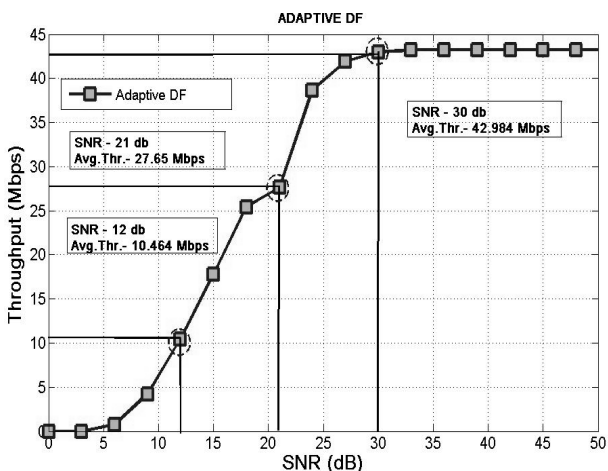

그림 11. 적응적 MCS DMF 프로토콜의 평균 전송률  
 Fig. 11. Average Throughput of Adaptive MCS DMF Protocol.



그림 12. 적응적 MCS 릴레이 프로토콜의 최대 전송률 분석

Fig. 12. Maximum Throughput Analysis of Adaptive MCS Relay Protocols.

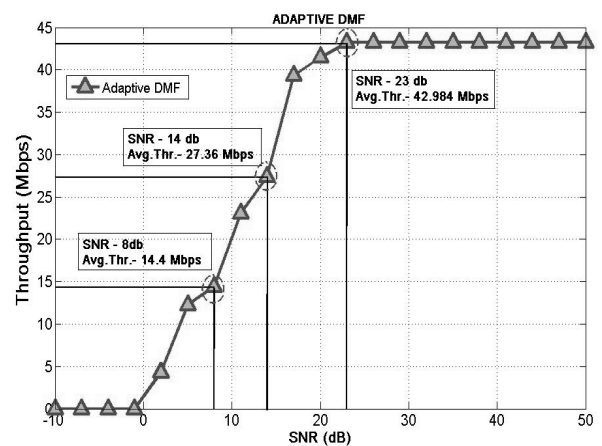

그림 13. 적응적 MCS 릴레이 프로토콜의 최소 전송률 분석

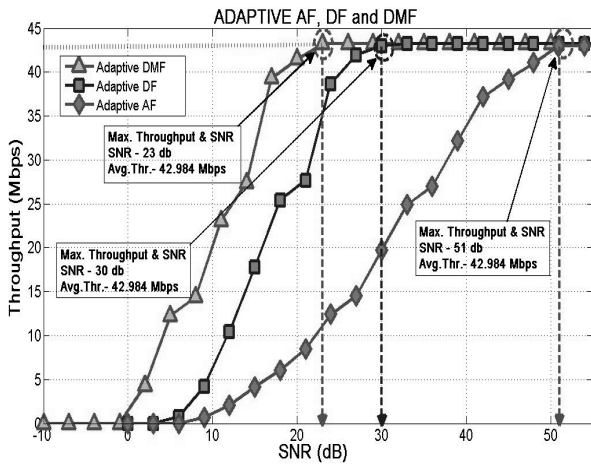
Fig. 13. Minimum Throughput Analysis of Adaptive MCS Relay Protocols.

Fig. 12 shows the Maximum throughput analysis comparing all the protocols in the case of the adaptive relay with MCS. Here, we observe that the DMF protocol shows a gain of 7 dB compared to the DF protocol. DMF attains the maximum throughput at the SNR of 23 dB and the DF gains maximum throughput at 30 dB. Similarly, as compared to the DF and AF, DF gains maximum throughput at 51 which is far worse than the case of DF, DF clearly shows the SNR gain of 21 dB.

Fig. 13 shows the performance of the AF, DF and DMF Adaptive MCS relay with minimum average

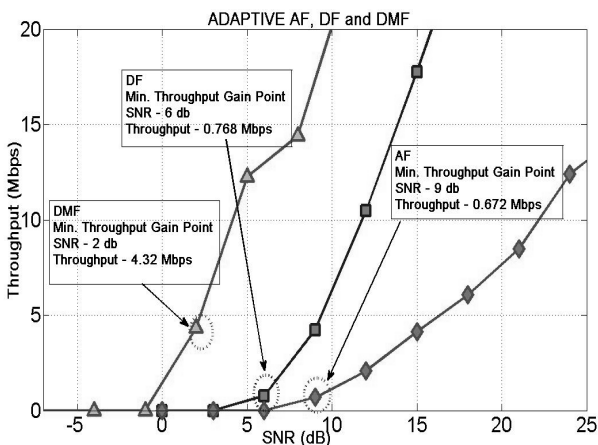
throughput. This is in contrast with the Maximum throughput case where DMF and DF show very close performance but the performance of AF and DF show a dramatic change in gain and prove AF as the worst. In this case, DMF shows the Minimum throughput gain at 2 dB with 4.32 Mbps, whereas DF shows the throughput gain at SNR 6 dB with 0.768Mbps and AF with SNR 9 dB and a throughput of 0.672 Mbps. This shows that in reverse of the maximum throughput, the minimum throughput demonstrates that the DMF protocol has consistent performance at high and low SNR values.

## V. Conclusions

We propose an AMC scheme using relay protocols like AF, DF and DMF. The behaviors of these protocols are analyzed on parameters as BER, SER, FER, maximum throughput, average throughput and Minimum throughput. We use the AMC scheme for improving throughput and reliability, because of the nature of different modulation and coding schemes. The simulation results of the proposed system with adaptive MCS prove that among the AF, DF and DMF protocol, the DMF protocol performs best specifically at a lower SNR value and also provides better average throughput. We observed that the proposed DMF protocol is capable of performing with the best performance in lower and high SNR values and with high consistency and provides the best throughput efficiency. The main consideration point in the proposed mechanism is the application of the DMF protocol which when implemented with the AMC scheme shows outstanding results compared to the conventional AF and DF schemes.

## References

- [1] R. Pabst, B. H. Walke, D. C. Schultz, et al., "Relay-based deployment concepts for wireless and mobile broadband radio," IEEE Commun.



- Mag., vol. 42, no. 9, pp. 80 - 89, Sep. 2004.
- [2] S. W. Peters, A. Y. Panah, Kien T. Truong, and R. W. Heath, Jr., "Relay architectures for 3GPP LTE-advanced," EURASIP J. Wireless Communication and Network., vol. 2009, Article ID 618787, 14 pages, 2009.
- [3] S. Sesia, I. Toufik, and M. Baker, LTE, The UMTS Long Term Evolution: From theory to practice, Wiley & Sons, Feb. 2009.
- [4] J. N. Laneman, D. N. C. Tse, and G. W. Wornell, "Cooperative diversity in wireless networks: Efficient protocols and outage behaviour," IEEE Transactions on Information Theory, vol. 50, no. 12, pp. 3062 - 3080, Dec 2004.
- [5] A. Sendonaris, E. Erkip, and B. Aazhang, "User cooperation diversity-part i: System description," IEEE Transactions on Communications, vol. 51, no. 11, pp. 1927 - 1938, Nov 2003.
- [6] A. Sendonaris, E. Erkip, and B. Aazhang, "User cooperation diversity - part ii: Implementation aspects and performance analysis," IEEE Transactions on Communications, vol. 51, no. 11, pp. 1939 - 1948, Nov 2003.
- [7] G. Holland, N. Vaidya and P. Bahl, "A rate-adaptive MAC protocol for multi-hop wireless networks," Proc. of the 7th MobiCom, pp.236-251, Rome, Italy, 2001.
- [8] Saransh Malik, Sangmi Moon, Bora Kim, Cheolhong Kim, Intae Hwang, "Joint Precoding Technique for Interference Cancellation in Multiuser MIMO Relay Networks for LTE-Advanced System", Journal of The Institute of Electronics Engineers of Korea, Vol. 49-TC, No. 6, June 2012.
- [9] S.G. Chua, A.J. Goldsmith, "Adaptive coded modulation for fading channels", IEEE Transaction on communications, May 1998, pp. 595-602.
- [10] S.K. Lai, R.S. Cheng, K.B. Letaief, R.D. Murch, "Adaptive trellis coded MQAM and power optimization for OFDM transmission", IEEE Vehicular Technology Conference, May 1999, pp. 290-295.
- [11] Jeonghwan Lee, Gilsang Yoon, Insik Cho, Changwoo Seo, Sherlie Portugal and Intae Hwang, "Design and Performance Analysis of a Communication System with AMC and MIMO Mode Selection Scheme", Journal of The Institute of Electronics Engineers of Korea, Vol. 47-TC, No. 3, March 2010.
- [12] T. Keller, L. Hanzo, "Adaptive modulation techniques for duplex OFDM transmission", IEEE Transaction on Vehicular Technology, Sept 2000, pp. 1893-1906.
- [13] J. G. Proakis, Digital Communications, 4th ed. McGraw-Hill, New York, 2001.

저 자 소 개



사란쉬 말리크(학생회원)  
2010년 라지프 간디 공과대학  
IT학과 학사  
2011년 3월~현재 전남대학교  
전자컴퓨터공학과 석사과정  
<주관심분야 : MIMO, OFDM,  
Relay>



김 대 진(평생회원)  
1984년 서울대학교  
전자공학과 학사  
1986년 한국과학기술원  
전기 및 전자공학과 석사  
1991년 한국과학기술원  
전기 및 전자공학과 박사  
1991년 7월 1996년 12월 LG전자 멀티미디어연구  
소 책임연구원  
1997년~현재 전남대학교 전자컴퓨터공학부 교수  
<주관심분야 : 디지털 통신, 디지털 방송>



김 보 라(학생회원)  
2012년 2월 전남대학교  
전자컴퓨터공학부 학사  
2012년 3월~현재 전남대학교  
전자컴퓨터공학과 석사과정  
<주관심분야 : 이동통신, CoMP>



황 인 태(평생회원)  
1990년 2월 전남대학교  
전자공학과 학사  
1992년 8월 연세대학교  
전자공학과 석사  
1999년 9월~2004년 2월 연세대  
학교 전기전자공학과 박  
사  
1992년 8월~2006년 2월 LG전자 책임 연구원  
2006년 3월~현재 전남대학교 전자컴퓨터공학부  
교수  
<주관심분야 : 디지털통신, 무선통신시스템,  
mobile terminal system for next generation,  
physical layer software for mobile terminal,  
efficient algorithms for AMC, MIMO and  
MIMO-OFDM, Relaying scheme for wireless  
communication>



문 상 미(학생회원)  
2012년 2월 전남대학교  
전자컴퓨터공학부 학사  
2012년 3월~현재 전남대학교  
전자컴퓨터공학과  
석사과정  
<주관심분야 : 이동통신, ICIM>