

Cross-Layer Resource Allocation Scheme for WLANs with Multipacket Reception

Lei Xu, Dazhuan Xu, Xiaofei Zhang, and Shufang Xu

Tailored for wireless local area networks, the present paper proposes a cross-layer resource allocation scheme for multiple-input multiple-output orthogonal frequency-division multiplexing systems. Our cross-layer resource allocation scheme consists of three stages. Firstly, the condition of sharing the subchannel by more than one user is studied. Secondly, the subchannel allocation policy which depends on the data packets' lengths and the admissible combination of users per subchannel is proposed. Finally, the bits and corresponding power are allocated to users based on a greedy algorithm and the data packets' lengths. The analysis and simulation results demonstrate that our proposed scheme not only achieves significant improvement in system throughput and average packet delay compared with conventional schemes but also has low computational complexity.

Keywords: Wireless local area networks (WLANs), multiple-input multiple-output orthogonal frequency-division multiplexing (MIMO-OFDM), beamforming, distributed co-ordination function (DCF), cross-layer resource allocation, multipacket reception (MPR) .

Manuscript received May 2, 2010; revised Sept. 23, 2010; accepted Oct. 11, 2010.

This work was supported by the National Nature Science Foundation of China, P.R. China (60801052, the research polarization sensitive array signal processing based on three linear/multilinear decomposition theory), Enterprises-universities-researches Foundation of Jiangsu Province, P.R. China (BY2009101, the research of key technologies for multi-hop wireless phone/data network based on IEEE 802.11 DCF protocol), and Aeronautical Science Foundation of China, P.R. China (2009ZC52036, the research of high-speed adaptive short-wave radio).

Lei Xu (phone: +86 25 84896490 12413, email: xulei23@nuaa.edu.cn), Dazhuan Xu (email: dazhuanxu@nuaa.edu.cn), Xiaofei Zhang (email: xiaofeizhang@nuaa.edu.cn), and Shufang Xu (shufangxu@nuaa.edu.cn) are with the College of Electronic and Information Engineering, Nanjing University of Aeronautics and Astronautics, Nanjing, China.
doi:10.4218/etrij.11.01.10.0258

I. Introduction

Wireless local area networks (WLANs) based on the IEEE 802.11 standard are becoming more popular and are increasingly relied upon [1]. One reason is that they keep increasing data transmission rates while maintaining a relatively low price. Conventional designs for WLANs follow a layered approach. However, the conventional layered approach usually operates far away from the theoretical limits. In order to improve the performance of WLANs, we should exploit the cross-layer design approach, such as jointly taking into account the physical (PHY) layer and media access control (MAC) layer parameters.

At the PHY layer, multiple-input multiple-output (MIMO) combined with orthogonal frequency-division multiplexing (OFDM) is becoming an attractive solution for future broadband wireless systems [2]-[4]. The structure of concatenating eigen-beamforming and space-time block coding based on outdated channel state information (CSI) for MIMO-OFDM systems is proposed in [5]. Based on the results of [5], an adaptive MIMO-OFDM transmitter by applying an adaptive two-dimensional coder-beamformer in each subcarrier is investigated in [6]. Though different from [6], a dynamic spatial subchannel allocation with adaptive beamforming for MIMO-OFDM systems is proposed in [7].

At the MAC layer, the IEEE 802.11 system adopts a distributed coordination function (DCF) protocol as a fundamental mechanism to access the medium [8], [9]. A simplistic collision model, which is a DCF protocol with a CSMA/CA mechanism and only supports one simultaneous transmission, is employed in the conventional WLANs. Multipacket reception (MPR) is a powerful capacity-enhancement technique at the system level [10]. With the

development of advanced signal processing techniques, MPR has become a feasible solution in practical systems, and this brings a new challenge as well as opportunities for the MAC protocol design [11], [12]. A finite-user slotted Aloha-type random access protocol with MPR capacity at the base station is considered in [12]. Similar to the Aloha system, MPR technology can be applied to WLANs [11]. IEEE 802.11n standard is the first WLAN standard based on MIMO-OFDM technologies and aims at a higher throughput. However, its collision model is still unchanged, which motivates the use of MPR to resolve collision and increase the network capacity.

Resource allocation algorithms for OFDM systems have been extensively studied by many scholars. A joint subcarrier and power allocation scheme in uplink of OFDMA system is proposed in [13]. A novel algorithm to the subcarrier and bit allocation problem with proportional fairness constraints for multiuser OFDM systems is presented in [14]. In [15], a transmit power adaptation method which maximizes the total data rate of multiuser OFDM system is developed. The authors of [16] investigate the problem of dynamic multiuser subchannel allocation and propose a low-complexity adaptive subchannel allocation algorithm with the equally divided power across the subcarriers. The resource allocation problems in IEEE 802.11 WLANs have been investigated in [17], [18]. A novel algorithm for channel allocation in bandwidth WLANs and an improved resource reservation mechanism applied to IEEE 802.11 MAC protocol are proposed in [17]. A proposal was made for a resource allocation strategy for conversational, streaming, and interactive services in cellular/WLAN interworking [18].

The above mentioned works do not take the cross-layer design into consideration. A cross-layer design framework is proposed for 802.11-based uplink MIMO-OFDM systems, which jointly designs the MPR-based MAC protocol and adaptive resource allocation [11]. However, the cross-layer resource allocation scheme in [11] adopts the exhausted search method by search $(M+1)$ Lagrange multipliers and the computational complexity is very high. The number of users accessing the network is denoted by M . Furthermore, [11] adopts the total power constraints of the system instead of individual power constraints per user, which is not suitable for the practical situation. In this paper, we model the optimization problem with individual power constraints per user for uplink MIMO-OFDM systems and propose a low complexity resource allocation with MPR for WLANs. Firstly, the power of each user is assumed to be uniformly allocated across the corresponding subchannel set per user, and the subchannels are allocated to the combination of users under the proportional rate constraint. Then, the scheme assigns one bit to the user with the least normalized transmit rate, and the user greedily

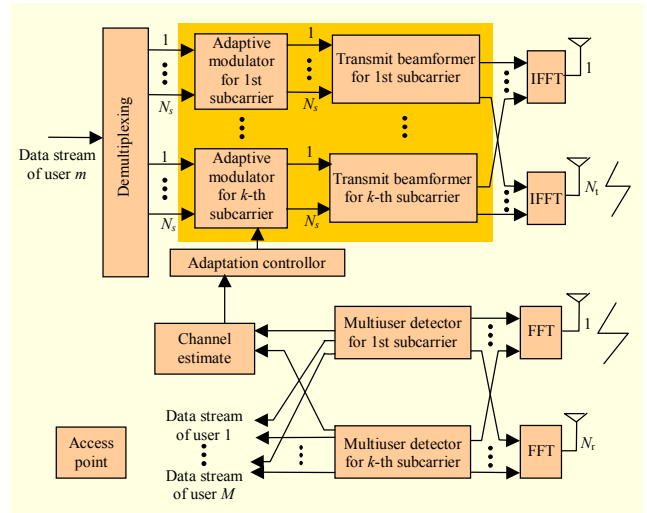

Fig. 1. System block diagram of PHY layer for WLAN.

allocates the bit and corresponding power to obtain the greatest benefit. The simulation results demonstrate that our proposed scheme achieves a significant increase in system throughput and an improvement in average packet delay compared with conventional schemes.

II. System Model

1. MIMO-OFDM System Model at the PHY Layer

MIMO-OFDM system model at the PHY layer is given in Fig. 1. The multiuser MIMO-OFDM system with beamforming is considered where the number of transmit antennas, receive antennas, and OFDM subcarriers are N_t , N_r , and K , respectively. There are M users to access the medium, which is selected among M_t users. M_t is the total number of users of our network. Per OFDM subcarrier, we deploy the adaptive modulator and transmit beamformer. Each subcarrier has N_s parallel spatial subchannels. In our system, multiple users can transmit in the same subchannel, and the superimposed signals can be separated at the access point (AP) using multiple-antenna techniques. Maximum-likelihood multiuser detection is adopted in our system, which maximizes the posteriori probability.

The AP obtains the perfect CSI upon the reception of RTS packets. Because transmitting the data packet occurs later than the reception of the RTS packet, the AP performs the resource allocation using the outdated CSI. The feedback CSI is denoted by $H^f[m; k] \in \mathbb{C}^{N_r \times N_t}$, which is drawn from the same Gaussian distribution as $H[m; k] \in \mathbb{C}^{N_r \times N_t}$ but Δt seconds ahead. When the data packet is transmitted, the CSI is denoted by $H[m; k] \in \mathbb{C}^{N_r \times N_t}$. Let $\rho = J_0(2\pi f_d \Delta t)$ denote the correlation coefficient specified by the Jakes' model where $J_0(\bullet)$ is the

zeroth-order Bessel function of the first kind. The minimum mean square error (MMSE) predictor of $H[m; k] \in \mathbb{C}^{N_r \times N_t}$ is $\overline{H[m; k]} = E[H[m; k]H^H[m; k]] = \rho H^f[m; k]$. The conditional mean of $H[m; k] \in \mathbb{C}^{N_r \times N_t}$ given the feedback CSI $H^f[m; k] \in \mathbb{C}^{N_r \times N_t}$ is denoted by $\overline{H[m; k]} \in \mathbb{C}^{N_r \times N_t}$. To account for the prediction imperfections, the transmitter forms an estimate CSI $\hat{H}[m; k] \in \mathbb{C}^{N_r \times N_t}$ as

$$\hat{H}[m; k] = \overline{H[m; k]} + \Psi[m; k]. \quad (1)$$

The prediction error in (1) is $\Psi[m; k] \sim CN(0_{N_r \times N_t}, N_t \sigma_\epsilon^2[m; k] I_{N_t}) \in \mathbb{C}^{N_r \times N_t}$ and $\sigma_\epsilon^2[m; k] = (1 - |\rho|^2) \sigma_h^2$. σ_h^2 is the total energy of all FIR channels [5].

We consider the singular value decomposition (SVD) of the mean channel matrix per subcarrier as

$$\begin{aligned} \overline{H[m; k]} &= U[m; k] \overline{\Lambda}[m; k] W^H[m; k] \\ &= \sum_{j=1}^{N_s} u_j[m; k] \overline{\lambda}_j[m; k] v_j^H[m; k], \end{aligned} \quad (2)$$

where $\overline{\lambda}_j[m; k]$ is the singular value of the j -th subchannel in the k -th subcarrier, $u_j[m; k]$ and $v_j^H[m; k]$ are the left and right singular vectors associated with $\overline{\lambda}_j[m; k]$. The transmit-antenna weight vector is $v_j^H[m; k]$, and $u_j[m; k]$ is the receive-antenna weight vector.

2. Protocol Operation of MAC Layer

The transmission mode of MPR based on the IEEE 802.11 protocol with RTS/CTS mechanism is adopted in our paper (see Fig. 2). The condition of receiving multiple data packets by the AP is that the maximum number of users which can be transmitting simultaneously is not larger than the number of receiving antennas N_r . It is assumed that M users transmit successfully, and $M \leq N_r$. The probability of successful transmission is $\Pr\{M \leq N_r\}$:

$$\Pr\{M \leq N_r\} = \sum_{M=1}^{N_r} \frac{\binom{CW}{1} \binom{M_t}{M} (M_t - 1)^{CW-1}}{M_t^{CW}}. \quad (3)$$

Timing synchronization function (TSF) is specified in IEEE 802.11 WLAN standard to fulfilling timing synchronization among users. In this paper, we adopt the TSF to achieve the goal of timing synchronization among users.

The DCF protocol based on MPR is illustrated as follows.

Step 1. Users sense the channel to determine whether the medium is busy. If the medium is found to be idle for a distributed inter-frame space (DIFS) interval, each user chooses a random backoff counter value uniformly distributed in the range of $[0, CW-1]$. The contention window is denoted by CW .

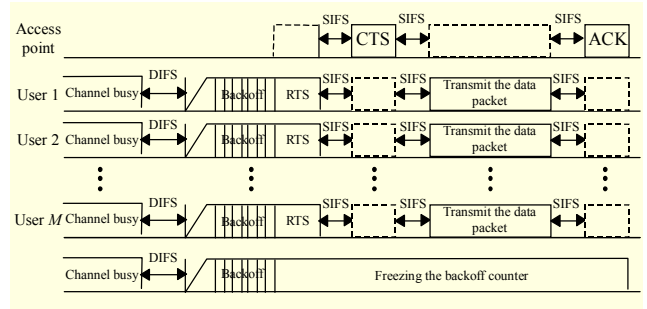

Fig. 2. DCF protocol based on MPR.

If the number of users with the same minimum backoff time doesn't exceed the number of receive antennas N_r , RTS packets are sent to the AP after the random backoff value decreases to zero. When the number of transmitting users exceeds N_r , collisions occur and the AP cannot decode any of the RTS packets. The users will retransmit their RTS packets after a backoff time period.

Step 2. Because the AP does not know the prior knowledge of the senders' identities and CSI, the blind detection scheme which is described in [19] is needed to separate the RTS packets and is applied to estimate the CSI simultaneously. 802.11 systems exploit the structure of RTS/CTS packets to estimate the CSI [20]. RTS packets are typically transmitted at a lower data rate than the data packets in IEEE 802.11 so that blind detection schemes are suitable for detecting RTS packets. Once separating multiple users' RTS packets, the AP performs the cross-layer allocation scheme. After a short inter-frame space (SIFS), CTS packet is broadcast to notify the accessing users.

Step 3. Upon receiving the CTS packet, the accessing users begin to transmit the data packets after waiting an SIFS interval. Since the multiple stations transmit their data packets at the same time, their training sequences should be mutually orthogonal. In our system, no more than N_r simultaneously transmissions are allowed. Therefore, a total of N_r orthogonal sequences are required to be predefined and made known to all stations. The sequence allocation decision is sent to the users via the CTS packet.

Step 4. During the data transmission phase, CSI is estimated from the orthogonal training sequences that are transmitted in the preamble of the data packets. The AP can separate the multiple data packets with the estimated CSI by means of multiple user detection, such as MMSE receiver or maximum-likelihood (ML) receiver. An acknowledgement (ACK) packet is sent to the users after data packets are successfully transmitted.

Step 5. When the number of transmitting users exceeds N_r , collisions occur, and the AP cannot decode any of the RTS packets. The users will retransmit their RTS packets after a backoff time period and the contention window CW is doubled.

If a packet error is detected at the AP or an ACK is not received within ACK_{timeout} period, retransmission is also required. Upon successfully transmission of a packet, CW is reset to CW_{min} . The minimum backoff time value is represented by CW_{min} .

The carrying information of control packets is as follows. RTS packet carries the competitive user address, the AP address, and the data packet's length. CTS packet carries the resource allocation results, the accessing users' CSI, the accessing users' addresses, and the orthogonal training sequence allocation decision. ACK packet carries the accessing users' addresses.

III. Problem Formulation

The optimization objective can be set to be minimizing the transmission time given the requirement of the bit error rate (BER) and power constraint of each user. Cross-layer optimization problem can be formed as

$$\begin{aligned}
& \text{Minimize: } T_{\text{max}} \\
& \text{s.t.: C1. } \sum_{k=1}^K \sum_{j=1}^{N_s} \sum_{i=1}^{2^M} \alpha_{j,i,k} c_{j,i,k} p_{m,j,i,k} \leq P_{\text{total}}^m, \quad \forall m, \\
& \text{C2. } \overline{BER}_{m,j,k} \leq \overline{BER}_{\text{target}}, \quad \forall m, k, j, \\
& \text{C3. } \frac{\sum_{k=1}^K \sum_{j=1}^{N_s} \sum_{i=1}^{2^M} \alpha_{j,i,k} c_{j,i,k} b_{m,j,i,k}}{\sum_{k=1}^K \sum_{j=1}^{N_s} \sum_{i=1}^{2^M} \alpha_{j,i,k} c_{j,i,k} b_{m+1,j,i,k}} = \frac{R_m}{R_{m+1}}, \quad \forall m, \\
& \text{C4. } T_{\text{max}} = \max_{m \in \{1, 2, \dots, M\}} \left(\frac{R_m}{\sum_{k=1}^K \sum_{j=1}^{N_s} \sum_{i=1}^{2^M} \alpha_{j,i,k} c_{j,i,k} b_{m,j,i,k}} \right), \\
& \text{C5. } \sum_{i=1}^{2^M} \alpha_{j,i,k} c_{j,i,k} \leq 1, \quad \forall k, j, \\
& \text{C6. } \alpha_{j,i,k} \in \{0, 1\}, c_{j,i,k} \in \{0, 1\}, p_{m,j,i,k} \geq 0, \\
& \quad b_{m,j,i,k} \geq 0, \quad \forall i, k, m, j.
\end{aligned} \tag{4}$$

Because more than one user could share the same subchannel, we define the indicator variable $\alpha_{j,i,k}$ as the admissibility of the i -th combination of users in the j -th subchannel of the k -th subcarrier. Each combination corresponds to a set of users. Hence, there are a total of 2^M combinations. For example, assume that $M=3$. A total of 9 combinations from (0, 0, 0) to (1, 1, 1) can be obtained. Each combination corresponds to a set of users where the value 1 or 0 indicates whether the corresponding user belongs to the user set. A combination is admissible when the channel correlation of every pair of users in the corresponding user set is lower

than $\delta_{\text{threshold}}$. The channel correlation of two users is defined in section IV.

The indicator $c_{j,i,k}$ allocates the j -th subchannel in the k -th subcarrier to the i -th combination of users. The rate and power of the m -th user for the i -th combination in the j -th subchannel of the k -th subcarrier are represented by $b_{m,j,i,k}$ and $p_{m,j,i,k}$, respectively. The maximum power constraint of user m is represented by P_{total}^m . The requirement of average BER is represented by $\overline{BER}_{\text{target}}$. The average BER of the m -th user in the j -th subchannel of the k -th subcarrier is denoted by $\overline{BER}_{m,j,k}$. The data packet length of user m is denoted by R_m . The maximum transmission time among M users is denoted by T_{max} .

The power constraint of each user is ensured by C1. The allocation policies which satisfy the BER requirement is represented by C2. The allocated data rates of each user within each OFDM symbol proportional to the users' packet length are denoted by C3. The maximum transmission time among M users is denoted by C4. That each subchannel can be only allocated to one combination of users is denoted by C5. The result of resource allocation to be feasible is denoted by C6.

Usually, minimizing the transmission time is equivalent to maximizing the data rate. From a physical layer point of view, the optimization objective can be set to be maximizing the total data rate given the QoS requirements and maximum power of each user. However, this may not be the case if we jointly consider more issues in the upper layer. For example, different users may have data packets with different lengths, which are determined by the characteristics of the applications. For this reason, the user which requires the most transmission time determines the total data transmission time in the network so that the data rates of each user are proportional to the users' packet length, see constraint C3.

IV. Cross-Layer Resource Allocation Scheme

1. Design the Constellation Distance Guaranteeing User's QoS

Before we give the cross-layer resource allocation scheme, we derive the constellation distance which satisfies the BER requirement. Firstly, we consider the SVD of the estimate channel matrix per subcarrier as

$$\begin{aligned}
\hat{H}[m; k] &= U[m; k] \hat{\Lambda}[m; k] V^H[m; k] \\
&= \sum_{j=1}^{N_s} u_j[m; k] \hat{\lambda}_j[m; k] v_j^H[m; k].
\end{aligned} \tag{5}$$

For each realization of $\hat{\lambda}_j[m; k]$, the BER in the presence of AWGN can be approximated as

$$BER_{m,j,k} \approx 0.2 \times \exp \left(-\frac{\hat{\lambda}_j^2[m;k] d_j^2[m;k]}{N_o} \right). \quad (6)$$

The validity of the approximation in (6) has also been confirmed in [21]. The constellation distance of user m in the j -th subchannel of the k -th subcarrier is denoted by $d_j^2[m;k]$. The variance of Gaussian white noise is denoted by N_o . Based on outdated CSI, the transmitter supposes $\hat{\lambda}_j[m;k]$ as a random variable and evaluates the average BER performance in the j -th subchannel of the k -th subcarrier as

$$\overline{BER}_{m,j,k} \approx 0.2 \times E \left[\exp \left(-\frac{\hat{\lambda}_j^2[m;k] d_j^2[m;k]}{N_o} \right) \right]. \quad (7)$$

The vector $H[\hat{m};k] v_j^H[m;k]$ is Gaussian distribution with $CN(\rho v_j^H[m;k] H^J[m;k], \sigma_\varepsilon^2 I_{N_t})$. Furthermore, we have $\hat{\lambda}_j^2[m;k] = \|H[\hat{m};k] v_j^H[m;k]\|_F^2$. For an arbitrary vector $a \sim CN(\bar{\alpha}, \Sigma)$, the following identity holds true [22]:

$$E \left\{ \exp(-a^H a) \right\} = \frac{\exp(-\bar{\alpha}^H (I + \Sigma)^{-1} \bar{\alpha})}{\det(I + \Sigma)}. \quad (8)$$

Applying (5), we obtain

$$\begin{aligned} \overline{BER}_{m,j,k} &\approx 0.2 \times \left(\frac{1}{1 + d_j^2[m;k] \sigma_\varepsilon^2 / N_o} \right)^{N_t} \\ &\times \exp \left(-\frac{\bar{\lambda}_j^2[m;k] d_j^2[m;k] / N_o}{1 + d_j^2[m;k] \sigma_\varepsilon^2 / N_o} \right). \end{aligned} \quad (9)$$

Approximating a Rician distribution by a Nakagami- m distribution, we can approximate the $\overline{BER}_{m,j,k}$ in (6) by

$$\begin{aligned} \overline{BER}_{m,j,k} &\approx 0.2 \\ &\times \left(1 + \frac{(1 + \chi_j[m;k]) d_j^2[m;k] \sigma_\varepsilon^2[m;k]}{Y_j[m;k] N_o} \right)^{-Y_j[m;k] N_t}, \end{aligned} \quad (10)$$

where $\chi_j[m;k] = \frac{\bar{\lambda}_j[m;k]}{N_r \sigma_\varepsilon^2[m;k]}$ and $Y_j[m;k] = \frac{(1 + \chi_j[m;k])^2}{1 + 2\chi_j[m;k]}$.

Set $\overline{BER}_{m,j,k} = \overline{BER}_{\text{target}}$, we can obtain $d_j^2[m;k]$.

$$\begin{aligned} d_j^2[m;k] &= \frac{N_o}{\sigma_\varepsilon^2[m;k]} \\ &\times \left[\frac{Y_j[m;k] (5\overline{BER}_{\text{target}})^{\frac{1}{Y_j[m;k] N_t}}}{1 + \chi_j[m;k]} - \frac{Y_j[m;k]}{1 + \chi_j[m;k]} \right]. \end{aligned} \quad (11)$$

2. Condition of Multiuser Sharing the Same Subchannel

We begin by defining the channel correlation of two users in the j -th subchannel of the k -th subcarrier. Let the mean channel matrices $H[m_1;k]$ and $H[m_2;k]$ of user m_1 and m_2 be decomposed into

$$\begin{aligned} \overline{H}[m_1;k] &= U[m_1;k] \bar{\Lambda}[m_1;k] V^H[m_1;k], \\ \overline{H}[m_2;k] &= U[m_2;k] \bar{\Lambda}[m_2;k] V^H[m_2;k]. \end{aligned} \quad (12)$$

Accordingly, the receive-antenna weight vectors $u^j[m_1;k]$ and $u^j[m_2;k]$ are equal to the j -th column vectors of $U[m_1;k]$ and $U[m_2;k]$. The channel correlation of user m_1 and user m_2 is defined by

$$\delta_{m_1, m_2}^j[k] = \left| (u^j[m_1;k])^H u^j[m_2;k] \right|. \quad (13)$$

Let $\delta_{\text{threshold}}$ denote the thresholds [11]. User m_1 and user m_2 are admissible in the same subchannel if and only if $\delta_{m_1, m_2}^j[k] < \delta_{\text{threshold}}$. $|\cdot|$ stands for the complex norm.

3. Cross-Layer Resource Allocation Scheme

Our cross-layer resource allocation scheme consists of two stages. In the first stage, we allocate the subchannel to the combination of users under the assumption that the power of each user is divided equally over admissible subchannels. In order to guarantee user rate proportionality, the user with the minimum normalized transmit rate T_m/R_m is allowed to choose a subchannel. The selected user will select a subchannel with the highest transmit rate on it. Suppose the user is m^* and the subchannel is (j^*, k^*) . Because of MPR, we need to select a combination of users which maximizes the throughput of subchannel (j^*, k^*) and contains the user m^* . In the second stage, we allocate the power of each user over the assigned subchannel set per user. The greedy algorithm can achieve the highest bitrate for the overall transmit power constraint in the single user case. Similar to the first stage, in order to satisfy the user rate proportionality, we allocate one more bit to the user with the least normalized rate T_m/R_m , and the user greedily allocates the bit to the subchannel which requires the least additional power to carry one more bit.

Before giving the resource allocation scheme, we define the following variables. The user set of the i -th combination in the j -th subchannel of the k -th subcarrier is denoted by $\phi_{j,i,k}$. The admissible subchannel set of user m is denoted by S_m^{tmp} . The number of subchannels contained in the set S_m^{tmp} is denoted by $N_{S_m^{\text{tmp}}}$. The bits allocated to user m in the j -th subchannel of the k -th subcarrier temporarily is denoted by $b_{m,j,k}^{\text{tmp}}$. The additional power $\Delta P_{m,j,k}$ is needed to transmit one more bit of user m in the j -th subchannel of the k -th subcarrier. The bits already allocated to user m are denoted by T_m . The normalized transmit throughput of user m is denoted

by ω_m . The power already allocated to user m is denoted by P_{consume}^m . The subchannels allocated to user m are recorded by S_m . The set of unallocated subchannels are recorded by S . The bits allocated to user m in the j -th subchannel of the k -th subcarrier is denoted by $b_{m,j,k}$.

The cross layer resource allocation scheme can be described as follows.

Step 1. We find the admissible combination of users in the j -th subchannel of the k -th subcarrier.

$$\alpha_{j,i,k} = \begin{cases} 1, & \text{if the } i\text{-th combination is feasible in the} \\ & j\text{-th subchannel of the } k\text{-th subcarrier,} \\ 0, & \text{else.} \end{cases} \quad (14)$$

Step 2. Find the admissible subchannel set of each accessing user. If $\alpha_{j,i,k} = 1$ and $m \in \phi_{j,i,k}$, $S_m^{\text{tmp}} = S_m^{\text{tmp}} + \{(j, k)\}$ and $N_{S_m^{\text{tmp}}} = N_{S_m^{\text{tmp}}} + 1$.

Step 3. Calculate the constellation distance $d_j^2[m; k]$ of user m in the j -th subchannel of the k -th subcarrier.

Step 4. Assume the power of user m is divided equally over $N_{S_m^{\text{tmp}}}$ subchannels. Then, $P_{\text{temp}}^m = P_m / N_{S_m^{\text{tmp}}}$. Calculate the rate $b_{m,j,k}^{\text{tmp}}$ of user m in the j -th subchannel of the k -th subcarrier:

$$b_{m,j,k}^{\text{tmp}} = \log_2 \left(1 + \frac{1.5 \times P_{\text{temp}}^m}{d_j^2[m; k]} \right). \quad (15)$$

Step 5. Initialization. Set $T_m = 0, S_m = \emptyset, \forall m$, and $c_{j,i,k} = 0, \forall j, i, k$. Set $S = \{(1, 1), \dots, (1, N_s), \dots, (K, 1), \dots, (K, N_s)\}$. Calculate $\omega_m = T_m / R_m$.

Step 6. While ($S \neq \emptyset$)

1. Find $m^* = \arg \min_m \{\omega_m\}$.
2. Find $(j^*, k^*) = \arg \max_{(j,k) \in S_{m^*}^{\text{tmp}}} b_{m^*,j,k}^{\text{tmp}}$.
3. Select the combination i^* which maximizes the throughput of subchannel (j^*, k^*) and contains user m^* . If more than one combination meets the conditions, select the combination with the maximum number of users.
4. If $m \in \phi_{j^*,i^*,k^*}$

$$\begin{aligned} S_m &= S_m + \{(j^*, k^*)\}, \\ S_m^{\text{tmp}} &= S_m^{\text{tmp}} - \{(j^*, k^*)\}, \\ T_m &= T_m + b_{m,j^*,k^*}^{\text{tmp}}, \forall m. \end{aligned}$$

End If

5. Set $c_{j^*,i^*,k^*} = 1$. Calculate $\omega_m = \frac{T_m}{R_m}$.

$$S = S - \{(j^*, k^*)\}.$$

End While

Step 7. $c_{j,i,k}$ is the final subchannel allocation result.

$$c_{j,i,k} = \begin{cases} 1, & \text{if the } i\text{-th combination is selected in the} \\ & j\text{-th subchannel of the } k\text{-th subcarrier,} \\ 0, & \text{else.} \end{cases} \quad (16)$$

Step 8. Initialization. Set $b_{m,j,k} = 0, T_m = 0, \omega_m = T_m / R_m, P_{\text{consume}}^m = 0, \Delta P_{m,j,k} = [(2^{b_{m,j,k}+1} - 2^{b_{m,j,k}}) / 1.5] d_j^2[m; k]$. Find $m^* = \arg \min_m \{\omega_m\}$. Find $(j^*, k^*) = \arg \min_{k \in S_{m^*}} \{\Delta P_{m^*,j,k}\}$.

Step 9. While ($P_{\text{consume}}^{m^*} + \Delta P_{m^*,j^*,k^*} \leq P_{\text{total}}^{m^*}$)

1. Find $m^* = \arg \min_m \{\omega_m\}$.
2. Find $(j^*, k^*) = \arg \min_{k \in S_{m^*}} \{\Delta P_{m^*,j,k}\}$.
3. Update $b_{m^*,j^*,k^*} = b_{m^*,j^*,k^*} + 1$,

$$P_{\text{consume}}^{m^*} = P_{\text{consume}}^{m^*} + \Delta P_{m^*,j^*,k^*},$$

$$\Delta P_{m^*,j^*,k^*} = \frac{2^{b_{m^*,j^*,k^*}+1} - 2^{b_{m^*,j^*,k^*}}}{1.5} d_{j^*}^2[m^*; k^*],$$

$$T_{m^*} = T_{m^*} + 1, \text{ Calculate } \omega_{m^*} = \frac{T_{m^*}}{R_{m^*}}.$$

End While

Step 10. $b_{m,j,k}$ is the final bit allocated to user m in the j -th subchannel of the k -th subcarrier.

Step 1 and step 2 find the admissible combination of users per subchannel and the admissible subchannel set of each accessing user. Step 3 and step 4 calculate the constellation distance $d_j^2[m; k]$ and the transmit rate in each subchannel with the uniform power allocation. Steps 5 through 7 allocate the subchannel to the combination of users. Steps 8 through 10 allocate the power of each user over the assigned subchannel set per user.

V. Computational Complexity Analysis

We begin to analyze the computational complexity of proposed scheme. Steps 1 and 2 need $O(2^M \times K \times N_s \times (M+1))$ operations to find the admissible combination of users and the admissible subchannel of each user. Steps 3 and 4 need $O(2 \times M \times K \times N_s)$ operations to calculate the constellation distance and bit. Steps 5 through 7 need $O(2^M \times K \times N_s \times M)$ operations to allocate subchannels to users. Steps 8 through 10 need $O(\sum_{m=1}^M T_m \times K \times N_s)$ operations to assign the power and bits. The total number of bits allocated to user m in an OFDM symbol is T_m .

To sum up, the total computational complexity of the proposed scheme is $O((2^M (M+2) + 2M + \sum_{m=1}^M T_m) KN_s)$.

Table 1. Computational complexity of all schemes.

Scheme name	Complexity
Proposed scheme	$O\left(\left(2^M(M+2)+2M+\sum_{m=1}^M T_m\right)KN_s\right)$
Kim's scheme [13]	$O\left(\left(2M+\sum_{m=1}^M T_m\right)KN_s\right)$
Yu's scheme [14]	$O\left(\left(M\log_2 KN_s+2M+\sum_{m=1}^M T_m\right)KN_s\right)$
Jang's scheme [15]	$O\left(\left(M+\sum_{m=1}^M T_m\right)KN_s\right)$
MaxMin scheme [16]	$O\left(\left(2M+\sum_{m=1}^M T_m\right)KN_s\right)$

The computational complexity of compared resource allocation schemes are summarized in Table 1.

VI. Numerical Results

MIMO-OFDM system with 64 subcarriers over a 20 MHz band is considered, which is equipped with 2 transmit antennas and 6 receive antennas. The equation $\overline{BER}_{target} = 1 \times 10^{-5}$ is chosen to maintain a low probability of packet error and retransmission. The feedback quality ρ is 0.8 at the transmitter and correspondingly we set $\delta_{threshold} = 0.4$. Likewise, the packet length which includes the payload and MAC header is uniformly distributed between 200 bytes and 1,500 bytes. The formats of the control packets, including RTS, CTS, and ACK, are designed based on the current 802.11a standard, which are composed of a frame control field (2 bytes), duration field (2 bytes), receiver address field (6 bytes), transmitter address (6 bytes, only in the RTS), and frame check sequence (FCS, 4 bytes). All the control packets are transmitted at a mandatory rate of 6 Mbps. The Rayleigh fading channel is assumed to be quasi-stationary within each data packet and is independent between different data packets. The other parameters used in the simulation are listed in Table 2. The SNR is defined as $SNR = P_{total}^m / (KN_o)$. Without loss of generality, all the users have the same power constraint P_{total}^m and $N_o = 1$. We adopt matlab to simulate the MAC protocol and perform various resource allocation schemes. In our simulation, the wireless channels are modeled as six-path Rayleigh fading channels with the exponential power delay profile and a root mean square (RMS) delay spread of 300 ns.

Table 2. Simulation parameters.

SLOT	9 μ s
SIFS	16 μ s
DIFS	34 μ s
PHY header	20 μ s
OFDM symbol duration	4 μ s
CTS _{timeout}	300 μ s
ACK _{timeout}	300 μ s
CW _{min}	8
CW _{max}	256

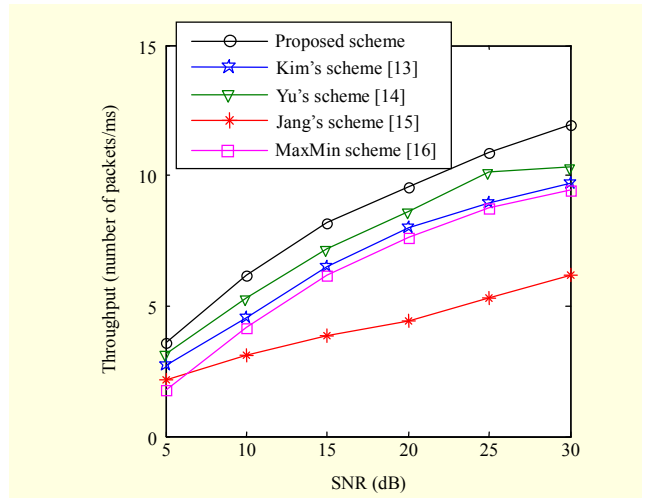

Fig. 3. Throughput versus different SNR: $K=64$, $N_t=2$, $N_r=6$, $M_t=30$, $\overline{BER}_{target} = 1 \times 10^{-5}$, and saturated traffic.

We perform the simulations for 10,000 runs and average the results, where each simulation run contains once successful MPR data transmission in WLAN.

The constraint condition of power in [11] is the total power of the system, so it is inconvenient and unfair for comparing our proposed scheme with [11]. For the purpose of performance comparison, we consider the following schemes: Kim's scheme [13], Yu's scheme [14], Jang's scheme [15], and the MaxMin scheme [16].

In order to compare other schemes with the proposed scheme fairly, transmit beamforming is adopted at the PHY layer, and IEEE 802.11 DCF protocol in [23] is adopted at the MAC layer in Kim's scheme [13], Yu's scheme [14], Jang's scheme [15], and the MaxMin scheme [16]. The simulation tool and channel model in [13]-[16] is the same as in the proposed scheme.

Figure 3 compares the throughput achieved by different schemes, as the SNR increases from 5 dB to 30 dB. We

Table 3. Standard deviations of all schemes in Fig. 3.

Scheme name	SNR					
	5	10	15	20	25	30
Proposed scheme	1.18	1.79	2.39	2.68	3.19	3.38
Kim's scheme [13]	0.85	1.21	1.49	1.72	2.06	2.40
Yu's scheme [14]	1.03	1.53	1.87	2.27	2.62	2.87
Jang's scheme [15]	0.84	1.32	1.71	1.91	2.13	2.24
MaxMin scheme [16]	1.10	1.17	1.38	1.65	2.03	2.30

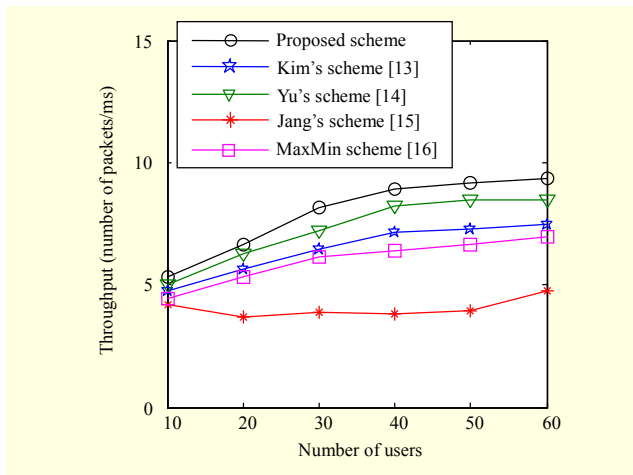

Fig. 4. Throughput versus different number of users: $K=64$, $N_f=2$, $N_r=6$, $SNR=15$ dB, $BER_{target} = 1 \times 10^{-5}$, and saturated traffic.

consider a system with 30 users and saturated traffic is assumed. We define the throughput as the average number of packets which are successfully received within a time unit (ms). Table 3 is the standard deviations of the results in Fig. 3. From Fig. 3, we can see that the proposed scheme can always achieve significant improvement in system throughput, compared to other schemes. Yu's scheme outperforms Kim's scheme, Jang's scheme, and the MaxMin scheme because Yu's scheme considers the packet length of selected users at the upper layer. The proposed scheme outperforms Yu's scheme because the proposed scheme adopts the MPR technology. From Table 3, we can observe that the standard deviation of the proposed scheme is larger than other compared schemes. This is because the proposed scheme takes greater advantage of opportunistic transmission than other schemes.

Figure 4 demonstrates the throughput versus different number of users in the network, as the number of users increases from 10 to 60. An SNR of 15 dB is assumed for all the cases, and saturated traffic is assumed. The proposed scheme outperforms other's schemes for both small-size and large-size systems. In addition, the system throughput of the

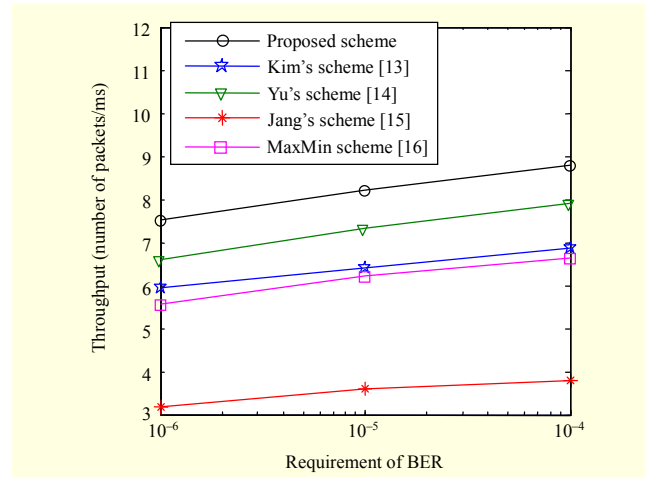

Fig. 5. Throughput versus different requirement of BER: $K=64$, $N_f=2$, $N_r=6$, $SNR=15$ dB, $M_f=30$, and saturated traffic.

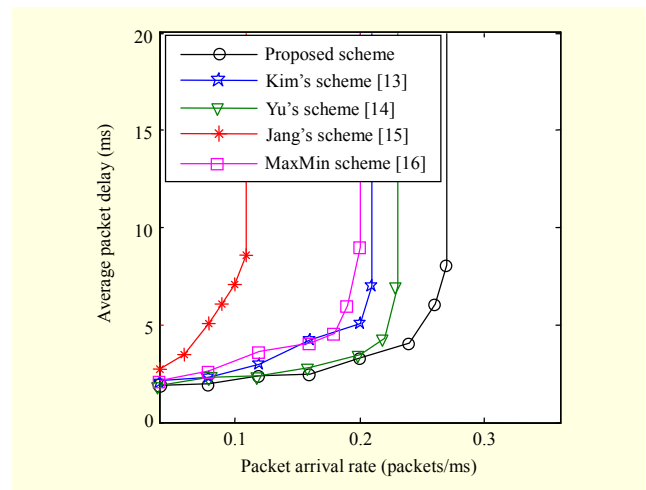

Fig. 6. Average packet delay versus packet arrival rate: $K=64$, $N_f=2$, $N_r=6$, $SNR=15$ dB, $M_f=30$, $BER_{target} = 1 \times 10^{-5}$, and unsaturated traffic.

proposed scheme increases with the number of users because of exploiting the multiuser diversity.

Figure 5 shows the throughput versus the different requirement of BER in the network. $SNR=15$ dB and $M_f=30$ are assumed for all the cases, and saturated traffic is assumed. From Fig. 5, we can see that the proposed scheme improves the system throughput significantly for all the cases when compared to other schemes.

Figure 6 shows the average packet delay versus packet arrival rates of different schemes. We define the packet delay as the time interval from the time the packet arrives, until an ACK for this packet is received. We consider a scenario in which $SNR=15$ dB and $M_f=30$. All the users have the same packet arrival rate. From Fig. 6, we see that for Yu's scheme the system becomes unstable when the packet arrive rate is larger

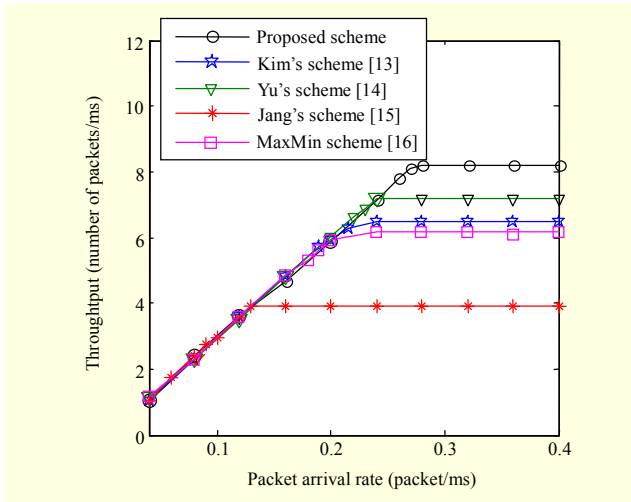

Fig. 7. Throughput versus different packet arrival rate: $K=64$, $N_t=2$, $N_r=6$, $SNR=15$ dB, $M_t=30$, $\overline{BER}_{\text{target}} = 1 \times 10^{-5}$, and unsaturated traffic.

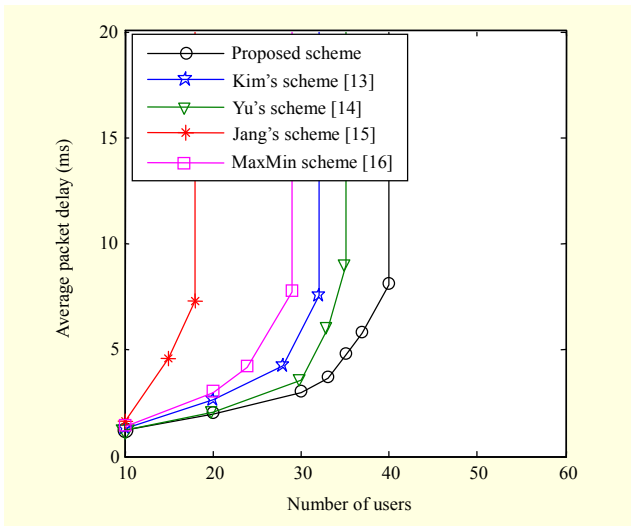

Fig. 8. Average packet delay versus different number of users: $K=64$, $N_t=2$, $N_r=6$, $SNR=15$ dB, $\overline{BER}_{\text{target}} = 1 \times 10^{-5}$, and unsaturated traffic of 0.2 packets/ms.

than 0.24 packets/ms. The performance of Kim's scheme, the MaxMin scheme, and Jang's scheme is even worse and result in an infinite packet delay when the packet arrival rate is more than 0.22 packets/ms, 0.21 packets/ms, and 0.13 packets/ms, respectively. However, our proposed scheme can keep the system stable as long as the packet arrival rate does not exceed 0.28 packets/ms. Also, the gap of packet delay between different schemes gradually diminishes as the traffic load decreases.

Figure 7 shows the throughput of different schemes under different packet arrival rate. We consider a scenario in which $SNR=15$ dB and $M_t=30$. All the users have the same packet

arrival rate. From Fig. 7, we notice that for each scheme has a threshold of packet arrival rate which has an important influence on the system throughput. The throughput linearly increases when the packet arrival rate is lower than such threshold. Otherwise, the throughput which is the network capacity of each scheme remains basically unchanged.

The average packet delay versus different number of users in the network is investigated in Fig. 8. We consider a scenario in which $SNR=15$ dB with a packet arrival rate of 0.2 packets/ms. From Fig. 8, we see that for Yu's scheme, Kim's scheme, the MaxMin scheme, and Jang's scheme, the system becomes unstable when the network size is larger than 36 users, 33 users, 30 users, and 20 users, respectively. Further observation shows that our proposed scheme can keep the system stable, as long as the network size does not exceed 41 users. We can obtain the conclusion that the proposed scheme could increase the network size efficiently.

VII. Conclusion

A cross-layer resource allocation scheme for WLANs was proposed in this paper. Our design objective was to minimize the transmission time by jointly using MPR and adaptive resource allocation technology. The AP performs the cross-layer resource allocation scheme based on outdated CSI and MPR technology while adhering to individual power constraints per user and QoS requirements and the allocated data rates of each user within each OFDM symbol proportional to the user's packet length. Simulation demonstrates that the proposed scheme can greatly enhance the system throughput and reduce the average packet delay compared to other schemes.

References

- [1] W.W. Wu et al., "Coexistence of OSCR-Based IR-UWB System with IEEE 802.11a WLAN," *ETRI J.*, vol. 28, no. 1, Feb. 2006, pp. 91-94.
- [2] S.H. Lee and J.S. Thompson, "Simulation Models for Investigation of Multiuser Scheduling in MIMO Broadcast Channels," *ETRI J.*, vol. 30, no. 6, Dec. 2008, pp. 765-773.
- [3] S.H. Lee, J.S. Thompson, and J-U. Kim, "QoS-Guaranteed Multiuser Scheduling in MIMO Broadcast Channels," *ETRI J.*, vol. 31, no. 5, Oct. 2009, pp. 481-488.
- [4] S.G. Kang, "The Minimum PAPR Code for OFDM Systems," *ETRI J.*, vol. 28, no. 2, Apr. 2006, pp. 235-238.
- [5] S.L. Zhou and G.B. Giannakis, "Optimal Transmitter and Eigen-Beamforming and Space-time Block Coding Based on Channel Mean Feedback," *IEEE Trans. Signal Process.*, vol. 50, no. 10, 2002, pp. 2599-2613.

- [6] P.F. Xia, S.L. Zhou, and G.B. Giannakis, "Adaptive MIMO-OFDM Based on Partial Channel State Information," *IEEE Trans. Signal Process.*, vol. 52, no. 1, 2004, pp. 202-213.
- [7] Y.H. Pan, K.B. Letaief, and Z.G. Gao, "Dynamic Spatial Subchannel Allocation with Adaptive Beamforming for MIMO/OFDM Systems," *IEEE Trans. Wireless Commun.*, vol. 3, no. 6, 2004, pp. 2097-2107.
- [8] D. Skordoulis et al., "IEEE 802.11n MAC Frame Aggregation Mechanisms for Next-Generation High-Throughput WLANs," *IEEE Wireless Commun.*, vol. 15, no. 1, 2008, pp. 40-47.
- [9] K.-C. Ting et al., "An Idle Listening-Aware Energy Efficient Scheme for the DCF of 802.11n," *IEEE Trans. Consumer Electron.*, vol. 55, no. 2, 2009, pp. 447-454.
- [10] Y.J. Zhang, P.X. Zheng, and C.L. Soung, "How Does Multiple-Packet Reception Capability Scale the Performance of Wireless Local Area Networks?" *IEEE Trans. Mobile Computing*, vol. 8, no. 7, 2009, pp. 923-935.
- [11] W.L. Huang, K.B. Letaief, and Y.J. Zhang, "Cross-Layer Multi-Packet Reception Based Medium Access Control and Resource Allocation for Space-Time Coded MIMO/OFDM," *IEEE Trans. Wireless Commun.*, vol. 7, no. 9, 2008, pp. 3372-3384.
- [12] N. Vidyut, M. Gokhan, and T. Lang, "Stability and Delay of Finite-User Slotted ALOHA with Multipacket Reception," *IEEE Trans. Inf. Theory*, vol. 51, no. 7, 2005, pp. 2636-2656.
- [13] K. Kim, Y. Han, and S.-L. Kim, "Joint Subcarrier and Power Allocation in Uplink OFDMA Systems," *IEEE Commun. Lett.*, vol. 9, no. 6, 2005, pp. 526-528.
- [14] G.D. Yu et al., "Subcarrier and Bit Allocation for OFDMA Systems with Proportional Fairness," *IEEE Wireless Commun. Networking Conf.*, vol. 3, 2006, pp. 1717-1722.
- [15] J. Jang and K.B. Lee, "Transmit Power Adaptation for Multiuser OFDM Systems," *IEEE J. Sel. Areas Commun.*, vol. 21, no. 2, 2003, pp. 171-178.
- [16] W. Rhee and J.M. Cioffi, "Increasing in Capacity of Multiuser OFDM System Using Dynamic Subchannel Allocation," *IEEE Vehicular Technol. Conf. Proc.*, vol. 2, 2000, pp. 1085-1089.
- [17] Y.B. Liu, C.C. Zhai, and S.X. Sun, "A Novel Algorithm of Channel Resource Allocation in IEEE 802.11 WLAN," *IFIP Int. Conf. Network Parallel Computing Workshops*, vol. 1, 2007, pp. 535-542.
- [18] W. Song and W.H. Zhang, "Resource Allocation for Conversational, Streaming, and Interactive Services in Cellular/WLAN Interworking," *IEEE Global Telecommun. Conf.*, vol. 1, 2007, pp. 4785-4789.
- [19] S. Talwar, M. Viberg, and A. Paulraj, "Blind Separation of Synchronous Co-Channel Digital Signals Using an Antenna Array, Part I: Algorithm," *IEEE Trans. Signal Process.*, vol. 44, no. 5, 1996, pp. 1184-1197.
- [20] Z. Kong et al., "Performance Analysis of IEEE 802.11e Contention-Based Channel Access," *IEEE J. Select. Areas Commun.*, vol. 22, no. 10, 2004, pp. 2095-2106.
- [21] A.J. Goldsmith and S.-G. Chua, "Adaptive Coded Modulation for Fading Channels," *IEEE Trans. Commun.*, vol. 46, no. 5, 1998, pp. 595-602.
- [22] G. Taricco and E. Biglieri, "Exact Pairwise Error Probability of Space-time Codes," *IEEE Trans. Inf. Theory*, vol. 48, no. 2, 2002, pp. 510-513.
- [23] IEEE Std 802.11a, "Wireless LAN Medium Access Control (MAC) and Physical Layer (PHY) Specifications," IEEE, 1999.



Lei Xu received the BS and MS in communication and information systems from Nanjing University of Aeronautics and Astronautics (NUAA) in 2006 and 2009, respectively. He is currently working towards the PhD in the College of Electronic and Information Engineering, NUAA. His research interests include optimization in wireless networks, adaptive resource allocation, WLAN, and WMN.



Dazhuan Xu graduated from Nanjing Institute of Technology, Nanjing, China, in 1983. He received the MS and PhD in communication and information systems from NUAA in 1986 and 2001, respectively. He is now a full professor in the College of Electronic and Information Engineering, NUAA. His research interests include ad hoc, WLAN, and WMN.



Xiaofei Zhang received the MS in electrical engineering from Wuhan University, Wuhan, China, in 2001. He received the PhD in communication and information systems from NUAA in 2005. He is a full professor in the College of Electronic and Information Engineering, NUAA, Nanjing, China. His research is focused on array signal processing and communication signal processing.



Shufang Xu received the MS in communication and information systems from NUAA in 2005. Currently, she is a PhD student in the College of Electronic and Information Engineering, NUAA, and also a teacher in communications at Hohai University, Nanjing, China. Her research interests include wireless networking, ad hoc, and UAV communication.