

Impulse Breakdown Behaviors of Dry Air as an Alternative Insulation Gas for SF₆

Feng Li* · Yang-Woo Yoo · Dong-Kyu Kim · Bok-Hee Lee**

Abstract

SF₆ gas, which has an excellent dielectric strength and interruption performance, is used in various applications such as gas insulated switchgear (GIS) in substations. However, since SF₆ has a high global warming potential (GWP), it is necessary to find an eco-friendly alternative insulation gas. In order to examine the possibility of using alternative insulation gases for SF₆ in power distribution system equipment, the dielectric strength and physical phenomena of dry air in a quasi-uniform electric field are investigated experimentally in this paper. As a result, the breakdown voltages for positive polarity are higher than those for negative polarity under impulse voltage applications. The negative 50[%] flashover voltage, V_{50} of dry air under conditions above 0.4[MPa] gas pressure, is higher than 150[kV], that is the basic impulse insulation level of distribution equipment. The V_{50} increases linearly with increasing the gas pressure, regardless of the waveform and polarity of the applied impulse voltages. The voltage-time curves are dependent on the rise time of the impulse voltage and gas pressure. Furthermore, streamer discharge was observed through light emission images by an ICCD camera under impulse voltage applications.

Key Words : Lightning Impulse Voltage, Switching Impulse Voltage, Damped Oscillatory Impulse Voltage, Breakdown Voltage-Time Characteristic, Dry Air, Alternative Insulation Gas

1. Introduction

Sulphur hexafluoride (SF₆) has been widely used as an insulating medium in electric power

transmission and distribution systems because of its superior insulating properties, high dielectric strength at relatively low pressures, as well as its thermal and chemical stability. The high dielectric strength of SF₆ results from its electronegative affinity [1,2], i.e., it tends to trap free electrons and converts them to negative ions. But SF₆ gas may cause global warming potential issues, contributing to the greenhouse effect. In the future there will be a requirement to reduce the use of the total volume of SF₆ gas from releasing into the atmosphere.

* Main author : School of Electrical Engineering,
Inha University

** Corresponding author : School of Electrical
Engineering, Inha University
Tel : +82-32-860-7398, Fax : +82-32-863-5822
E-mail : bhlee@inha.ac.kr
Date of submit : 2010. 12. 29
First assessment : 2011. 1. 4
Completion of assessment : 2011. 1. 24

Therefore, various studies have been carried out to find new alternative insulation gases to SF₆. N₂/SF₆ gas mixtures were, at the outset, considered as viable substitutes for SF₆, and investigations of their properties have currently intensified. They reduce the total amount of SF₆, but a drawback of such mixtures with SF₆ is the high cost of separation and recovery procedures [3-5]. In recent years, dry air and nitrogen (N₂) are expected as alternative candidates of pure SF₆ in distribution power system equipment since they are not harmful to the atmosphere. The 72.5[kV] gas insulated switchgear (GIS) is arranged in a gas tank filled with dry air at a gas pressure range up to 0.5-0.6[MPa] as an alternative gas to SF₆[6,7].

In order to obtain basic characteristics of the impulse breakdown of dry air under high gas pressure in a quasi-uniform field, we have carried out experimental studies on the impulse breakdown characteristics with a sphere-to-plane electrode configuration in dry air. The breakdown phenomena of dry air were compared with those of SF₆. The breakdown mechanism of dry air was analyzed by the simultaneous measurement of applied voltage, current and light emission waveforms.

2. Experiments

2.1 Experimental setup

In order to analyze the impulse breakdown characteristics of dry air in a quasi-uniform field, the experimental setup was designed and fabricated. Figure 1 shows a schematic diagram of the experimental setup and measurement systems.

The capacitor-type bushing with a basic impulse insulation level of 350[kV] was installed at the top of the test chamber. The test gap consists of the sphere-to-plane electrodes that were installed at the

lower part of the test chamber. Impulse voltages are generated by a Marx generator, and Figure 2 shows an equivalent circuit of an impulse voltage generator. When the switch S_w is closed, the damped oscillatory impulse voltage, with an oscillation frequency of 1MHz, is produced by triggering spark gap G₂.

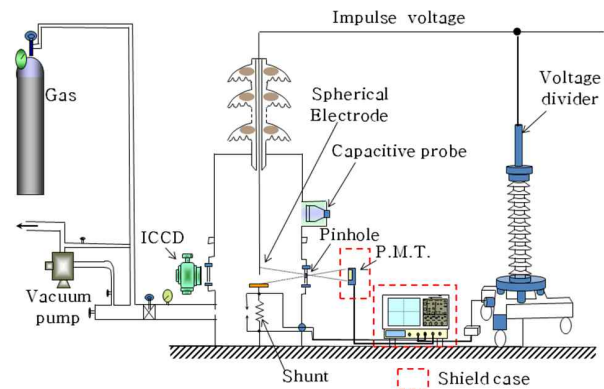

Fig. 1. Schematic diagram of the experimental setup

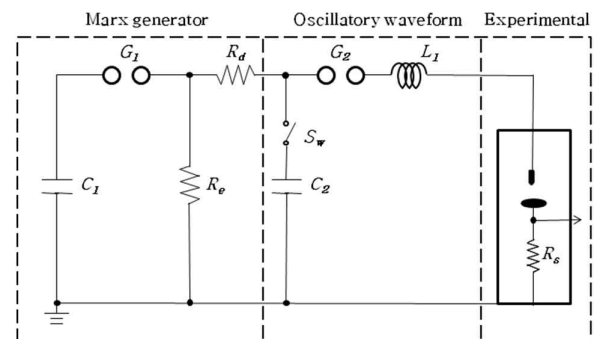

Fig. 2. Equivalent circuit of the test voltage generator

Figure 3 shows the detailed configurations of the sphere-to-plane electrodes which are made of stainless steel. The sphere is 50[mm] in diameter, and the diameter of the plane electrode is 90[mm]. The field utilization factor is 71.1[%] at a gap separation of 14[mm].

The applied voltage is measured by a capacitive impulse voltage divider with a DC-100[MHz]

bandwidth. A 50[Ω] shunt resistor with a spark gap was installed to detect the pre-breakdown current. An ICCD camera and photomultiplier tube (Hamamatsu C956) are placed so as to observe the light emission signal. The ICCD camera was triggered simultaneously with the Marx generator. The exposure time of the camera could range from 5[ns] to 10[ms]. The camera was connected to a computer for storage of the recorded images.

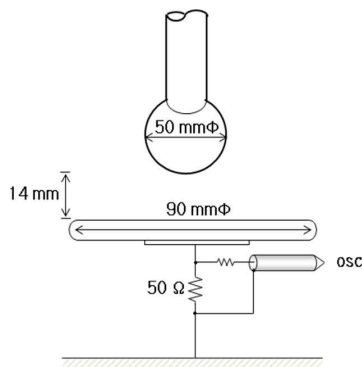

Fig. 3. Detailed configurations of the sphere-to-plane electrodes

2.2 Experimental method

The test chamber was evacuated by a vacuum pump and was filled with commercial grade-dry air when evacuated down to 0.133[kPa]. The absolute pressure of the gas is maintained at the level of 0.2 to 0.6[MPa] (converted for temperature of 20[°C]). Dry air consists of 20.9[%] O₂ and 79.1[%] N₂. The dielectric strengths were tested using negative and positive lightning impulse (1.2/50[μs]), switching impulse (180/250[μs]), and damped oscillatory impulse (500[ns]/1[MHz]) voltages, which can occur during the operation of gas insulated switchgears. Positive and negative impulse voltages were applied to the sphere electrode. The power source for the instruments was supplied through an isolation transformer and line filters in order to reduce

external noise. The pre-breakdown current is detected by a sensitive shunt resistor. The applied voltages, the pre-breakdown current waveforms, and the light emission signal were recorded by a digital storage oscilloscope with a sampling rate of 2.5[GS/s] and bandwidth of 500[MHz], simultaneously. An ICCD camera was used to observe the accumulated emission of light from discharge activities in the gas gap during voltage application.

3. Results and Discussion

3.1 Comparison between the breakdown voltages of SF₆ and dry air

The 25.8[kV] gas insulated switchgear (GIS) have been filled with pure SF₆. The SF₆ gas pressure ranges from 0.1 to 0.2[MPa]; the basic impulse insulation level according to the test procedures recommended in KS C 60129 is 150[kV][8]. In order to substitute SF₆ in 25.8[kV] gas insulated switchgear (GIS), we have investigated breakdown voltage characteristics of dry air as a function of gas pressure under impulse voltages.

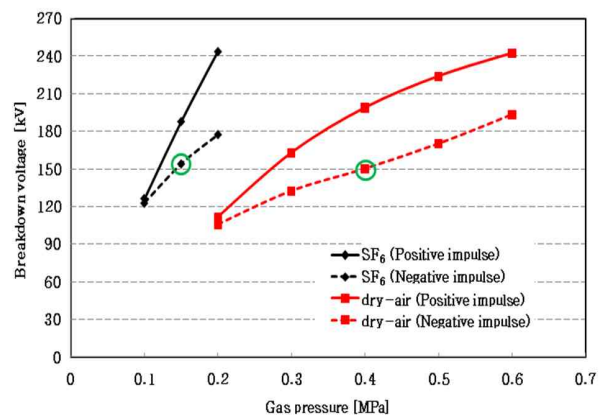

Fig. 4. *V*-*p* characteristics of SF₆ and dry air under lightning impulse voltages

Figure 4 shows breakdown voltage-gas pressure characteristics (V - p characteristics) of SF₆ and dry air under positive and negative lightning impulse voltages. The gap separation of sphere-to-plane electrodes is 14[mm].

The 50[%] breakdown voltage V_{50} was determined by means of the interpolation method. The positive and negative V_{50} of SF₆ are 187.5[kV] and 153[kV] at 0.15[MPa], respectively. The positive and negative V_{50} of dry air are 199[kV] and 150[kV] at 0.4[MPa], respectively. The V_{50} for positive lightning impulse voltage is higher than that for negative lightning impulse. The V_{50} of dry air is almost 2.67 times lower than that of SF₆ at the same gas pressure.

3.2 Pre-breakdown phenomena in dry air

The breakdown voltage, pre-breakdown current, and light emission signal under different lightning impulse voltages are measured to analyze the breakdown processes in dry air.

Figure 5 (a) shows typical waveforms of the breakdown voltage, current and light emission signals in dry air at 0.4[MPa] when the positive and negative lightning impulse voltages are applied to the sphere electrode, respectively. The positive and negative V_{50} are 199[kV] and 150[kV], respectively. Pulses corresponding to the electron avalanches and pre-breakdown streamer coronas were not observed in the waveforms of current and light emission signals. Figure 5 (b) shows typical waveforms of the breakdown voltage, current and light emission signals when the positive and negative switching impulse voltages are applied to the sphere electrode. The positive and negative V_{50} are 158[kV] and 135[kV], respectively. The V_{50} under switching

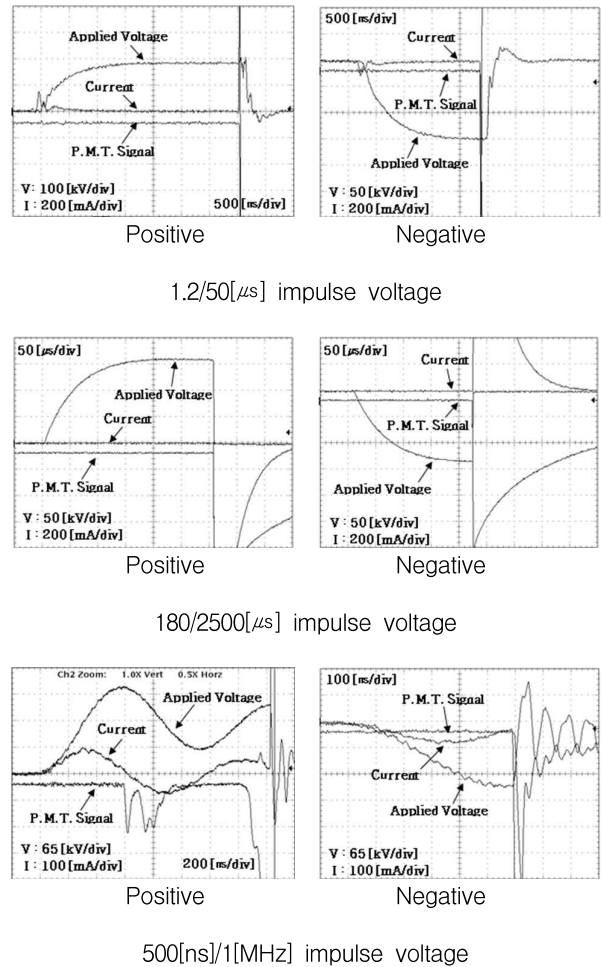

Fig. 5. Waveforms of the applied impulse voltage, current and light emission signals in dry air at 0.4[MPa]

impulses is lower than that under lightning impulses, but the time to breakdown with switching impulses is longer than that with lightning impulses. Figure 5 (c) shows typical waveforms of the breakdown voltage, current and light emission signals when the positive and negative oscillatory impulse voltages are applied to the sphere electrode. The positive and negative V_{50} are 220[kV] and 168[kV], respectively. The V_{50} under oscillatory impulse voltages are higher than that under lightning impulses, but the time to breakdown under oscillatory impulses is a little shorter than that

under lightning impulses.

The discharge in a quasi-uniform field is produced by streamer propagation. In the case of positive polarity, the initial electrons are produced by the process of the detachment of electrons from the impurities. The electrons flow into the sphere electrode, and the positive ions remain in a cone-shaped volume extending across the gap. A highly localized space-charge field is produced near the sphere electrode, but elsewhere in the gap the ion density is relatively low. However, in the gas surrounding the avalanche, photo electrons are produced by photons emitted from the densely ionized gas constituting the avalanche stem. These photoelectrons initiate subsequent avalanches, which are directed by both the space-charge field and the externally applied field. Positive ions are left behind by these avalanches and intensify the space-charge of the main avalanche towards the plane electrode. The process thus develops a self-propagating streamer, which effectively extends towards the plane electrode. Ultimately, a conducting filament of highly ionized gas bridges the gap between the electrodes. In the case of negative polarity, the initial electron is created by the field emission from the surface of sphere electrode. Streamers develop when the initial avalanche produces a sufficient number of electrons so that its space-charge field is comparable to the applied electric field[9].

3.3 V-t characteristics

The breakdown voltage - time characteristics ($V-t$ characteristics) of insulation gas are important in the insulation design and coordination of GIS and other power equipment[10]. Figure 6 shows the $V-t$ curves of dry air as a parameter of gas pressure. The $V-t$ curves are plotted by taking the maximum value of the applied voltage at or prior to breakdown

according to the test procedures recommended in IEC Standard 60060-2[11].

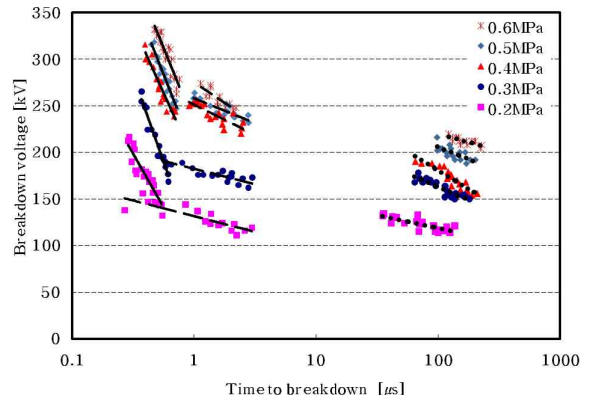

(a) Positive

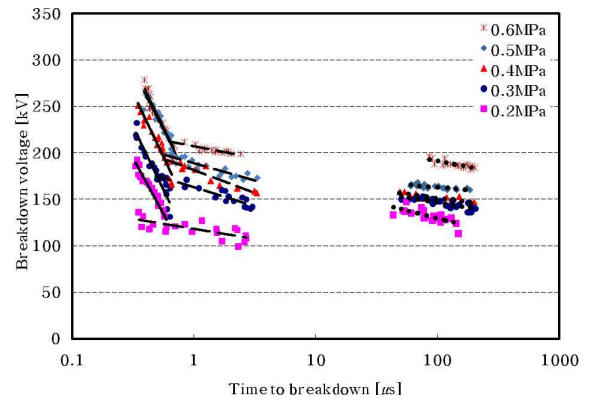

(b) Negative

Fig. 6. The $V-t$ characteristics in dry air as a parameter of gas pressure

In the case of lightning impulse, the shorter the time to breakdown is, the higher the breakdown voltage is. Similar behaviors on time dependency of breakdown phenomena were observed for switching impulse voltages and oscillatory impulse voltages. The breakdown voltages with switching impulses are lower than those with lightning impulses. However, the breakdown voltages under oscillatory impulse voltages are higher than those under lightning impulse voltages.

The $V-t$ curves for positive polarity are higher

than those for negative polarity in the same condition. Also, the $V-t$ curves for positive polarity are more strongly dependent on gas pressure than those for negative polarity.

3.4 V-p characteristics

The discharge in a quasi-uniform field is initiated by the initial avalanche inception. The initial avalanche to streamer transition is built, and the breakdown is followed by streamer propagation. Figure 7 illustrates the dependence of 50% breakdown voltage V_{50} on the gas pressure and waveforms of the applied voltage. The V_{50} is linearly increased with increasing the gas pressure, regardless of the polarity and shape of the applied voltage. The V_{50} under lightning impulses is higher than 150[kV] above 0.4[MPa] for negative polarity. V_{50} under oscillatory impulses shows the highest value, and V_{50} under switching impulse voltages is the lowest value.

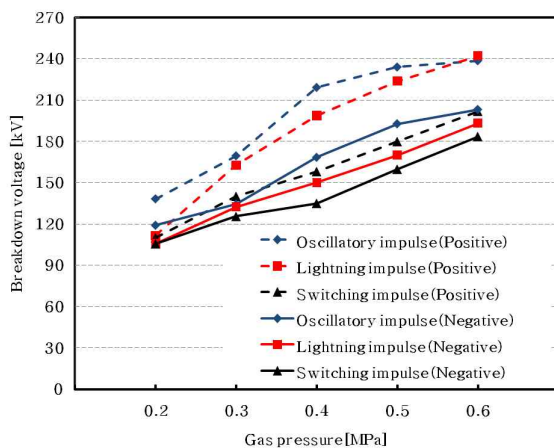

Fig. 7. $V-p$ characteristics in dry air

The breakdown in a quasi-uniform field is caused by streamer propagation because the transition from an electron avalanche into a streamer occurs in a very short time. The electron avalanche and

breakdown occur practically simultaneously. Therefore, the first corona onset voltage for a positive polarity is higher than that for negative polarity. Consequently, positive breakdown voltages are higher than negative breakdown voltages.

3.5 Breakdown Mechanism

In order to examine the breakdown phenomena, we have carried out measurements and observations of the applied voltages, discharge current and the light emission image. Figure 8 (a) shows waveforms of the applied positive impulse voltage, current and light emission signals, and Figure 8 (b) shows the light emission image of streamer discharge leading to the breakdown at 0.4[MPa]. Three light emission image pictures just before breakdown are sequentially photographed using the electronic shutter of an ICCD camera. The exposure time of each picture is 5[ns].

Via studying the effect of space-charge on the growth of an avalanche, Raether has observed that when the charge concentration is higher than 10^6 but lower than 10^8 , the growth of an avalanche is weakened. When the ion concentration exceeds 10^8 [ions/cm³], the avalanche current is followed by a steep rise in current and the breakdown of the gap follows[9].

In the case of Picture 1 in Figure 8, discharge light does not appear. But in Picture 2 in Figure 8, which is the discharge phenomena of 5[ns] later than that of Picture 1, a cathode directed streamer starts from the original avalanche head. This continues until a plasma channel connects cathode and anode as seen in Picture 3.

So, this discharge propagation process occurs in a very short period of time. In other words, the electron avalanche at the tip of the sphere is initiated when the electric field of the sphere

Impulse Breakdown Behaviors of Dry Air as an Alternative Insulation Gas for SF₆

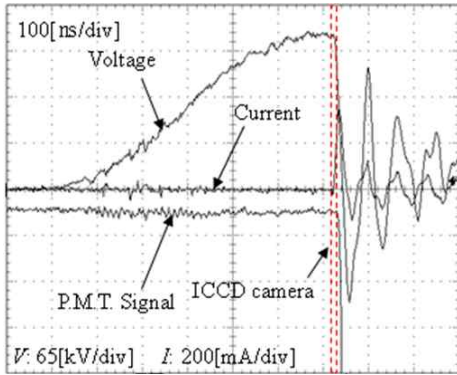

(a) Waveforms of the applied voltages, current and light emission signals

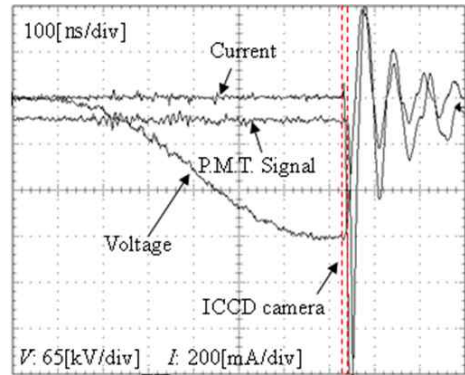

(a) Waveforms of the applied voltages, current and light emission signals

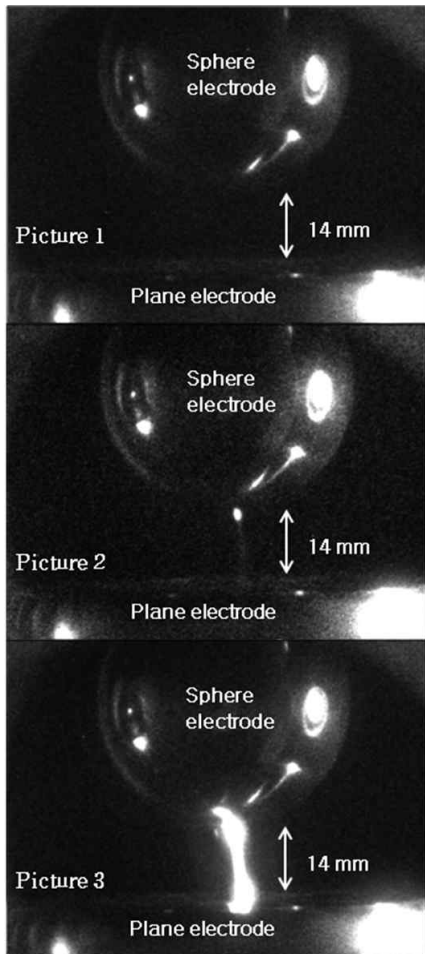

(b) Light emission image by ICCD camera

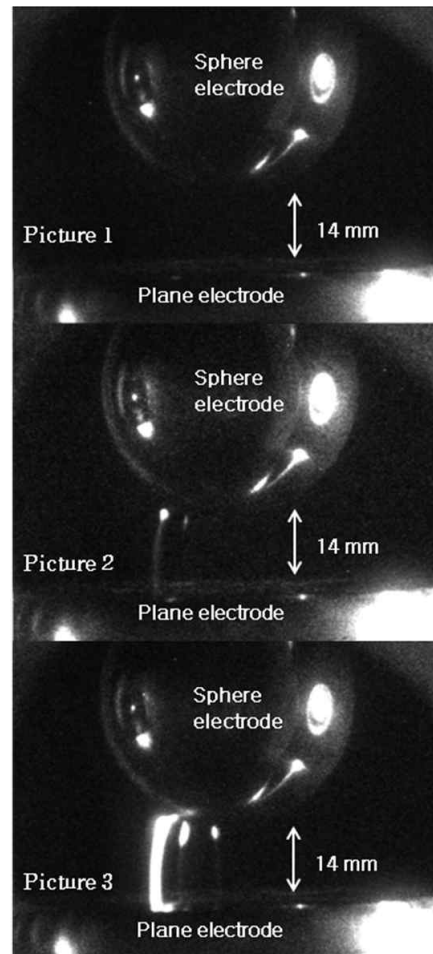

(b) Light emission image by ICCD camera

Fig. 8. Streamer discharge leading to breakdown under positive impulse voltages in dry air ($d=14$ [mm], $p=0.4$ [MPa])

Fig. 9. Streamer discharge leading to breakdown under negative impulse voltages in dry air ($d=14$ [mm], $p=0.4$ [MPa])

electrode reaches at the breakdown field intensity. Then, the transition from avalanche to streamer generally occurs when the ion concentration within the avalanche head reaches a critical value of $n=10^8$.

Figure 9 shows streamer discharge leading to breakdown under negative impulse voltages at 0.4[MPa]. In the case of negative polarity, the initial electron was created by the field emission on the surface of sphere electrodes, thus the electron avalanche for negative polarity occurs more easily than that for positive polarity, as shown in Picture 2 of Figures 9 (a) and (b). The anode directed streamer in Picture 2 of Figure 9 (b) starts from the original avalanche head.

4. Conclusion

We have conducted comparative studies for the impulse insulation characteristics of sphere-plane gap in dry air as a function of gas pressure and observed waveforms of the breakdown voltage, pre-breakdown current, light emission and impulse breakdown image, simultaneously. The results are summarized as follows:

- (1) The 50[%] breakdown voltage V_{50} of dry air in a sphere-plane electrodes gap with the field utilization factors of 71.1[%] is almost 2.67 times lower than that of SF₆ at the same gas pressure, and the V_{50} of the lightning impulse voltage in dry air is higher than 150[kV] above 0.4[MPa] for negative polarity.
- (2) The $V-t$ and $V-p$ characteristics for positive polarity are higher than those of negative polarity, respectively.
- (3) The V_{50} is linearly increased with increasing the gas pressure regardless of the polarity and waveform of the applied voltage.
- (4) In a quasi-uniform gap of short length, streamer discharge was identified with

corresponding current and PMT signal waveforms. In dry air, the electric breakdown propagates directly through the transition from the electron avalanche to streamer.

This work was supported by INHA UNIVERSITY Research Grant.

References

- [1] F. Li, Y.W. Yoo, D.K. Kim, and B.H. Lee, "Dielectric Characteristics of SF₆ and Dry-air Gases under Lightning Impulse Voltage," J. KIIEE, Vol. 24, No. 8, pp. 142-149, 2010.
- [2] H.K. Kang, J.B. Hah, Y.D. Chung, M.C. Ahn, D.K. Bae, T.K. Ko, "Study on the breakdown voltage characterization of insulation gases for developing a high voltage superconducting apparatus," IEEE Trans. On applied superconductivity, Vol. 20, No. 3, pp. 1646-1649, 2010.
- [3] T. Yamada, T. Ishida, N. Hayakawa, H. Okubo, "Partial Discharge and Breakdown Mechanism in Ultra-dilute SF₆/N₂ Gas Mixtures," IEEE Trans on DEI, Vol. 8, pp. 137-142, 2001.
- [4] T. Yamada, T. Takahashi, N. Hayakawa, A. Yoshida, and H. Okubo, "PD Extension Characteristics under ac High Voltage and ac/dc Breakdown Characteristics in SF₆/N₂ Gas Mixtures," Trans. IEE Japan, 119-A, pp. 891-896, 2001.
- [5] B.H. Lee, Y.H. Baek, H.S. Choi, and S.K. Oh, "Impulse Breakdown Characteristics of the Plane-to-Plane Electrode System with a Needle-shaped Protrusion in SF₆," Current Applied Physics, Vol. 7, No. 3, pp. 289-295, 2007.
- [6] H. Okubo and N. Hayakawa, "Dielectric Characteristics and Electrical Insulation Design Techniques of Gases and Gas Mixtures as Alternative of SF₆," Gaseous Dielectrics X, pp. 243-252, 2004.
- [7] T. Rokunoh, Y. Yagihashi, K. Aoyagi, T. Oomori, and F. Endo, "Development of SF₆-Free 72.5 kV GS," IEEE Trans. on Power Delivery, Vol. 22, No. 3, pp. 1869-1987, 2007.
- [8] KS C 4505, Disconnecting Switches, pp. 6-7, 2006.
- [9] E. Kuffel, W.S. Zeangl and J. Kuffel, High-Voltage Engineering-Fundamentals, 2nd ed., Newnes, Oxford, pp. 224-339, 2000.
- [10] B.H. Lee and T. Kawamura, "Transient Impulse Breakdowns of SF₆ Gas in Inhomogeneous Electric Fields," Jpn. J. Appl. Phys., Vol. 38, Pt. 1, No. 8, pp. 4898-4904, 1999.
- [11] High-voltage test techniques - Part 2: Test procedure, IEC 60060-2, p. 5, 2001.

Biography



Feng Li

He received his M.S. degree in Electrical Engineering from Inha University in 2006 and is attending his Ph.D. course at the same university. His branch research is lightning protection and gas discharge.

Tel : +82-32-860-7398

Fax : +82-32-863-5822

E-mail : lifeng197895@hanmail.net



Yang-Woo Yoo

He received his M.S. degree in Electrical Engineering from Inha University in 2009 and is attending his Ph.D. course at the same university. He had been working in the areas of R&D management of Korea Electrical Engineering & Science Research Institute since 1993 and joined the R&D Center of KD Power Company as the R&D Director in 2010. His branch research is lightning protection and grounding system.

Tel : +82-2-6336-3772

Fax : +82-2-6336-3789

<http://kdpower.co.kr>

E-mail : yookd@kdpower.co.kr



Dong-Kyu Kim

He received B.S. degree in Electrical Engineering from Hoseo University in 2009. He is now pursuing his M.S. degree at the School of Electrical Engineering at Inha University. His research interests are in the area of

surge protection and grounding systems

Tel : +82-32-860-7398

Fax : +82-32-863-5822

E-mail : electric02@naver.com



Bok-Hee Lee

He received his Ph.D. in Electrical Engineering from Inha University in 1987. He has been with the School of Electrical Engineering at Inha University, Incheon, Korea, as an Assistant Professor since 1990, and

became a Professor in 1999. From 1988 to 1989, he was a post-doctoral research fellow at the Institute of Industrial Science, University of Tokyo. From April 1999 to February 2000, he was a Visiting Professor at the University of Cincinnati. His research interests are in the area of lightning, lightning protection, grounding system, surge protection, high voltage engineering and electro-magnetic compatibility.

Tel : +82-32-860-7398

Fax : +82-32-863-5822

<http://heirc.inha.ac.kr>

E-mail : bhlee@inha.ac.kr