

# Nonlinear Speed Control of PM Synchronous Motor with Extended Kalman Filter Observer

Nga Thi-Thuy Vu\* · Jin-Woo Jung\*\*

## Abstract

This paper proposes a nonlinear speed controller for a permanent magnet synchronous motor (PMSM). In this paper, the load torque is estimated by an extended Kalman filter (EKF) observer because the proposed controller needs its knowledge. To confirm the effectiveness of the proposed control scheme, simulations and experiments are performed under motor parameter variations with a prototype PMSM drive system.

Key Words : Extended Kalman filter(EKF), Nonlinear control, Permanent magnet synchronous motor(PMSM), Speed control

## 1. Introduction

Permanent magnet synchronous motors (PMSM) are widely used in industrial applications because of their high power density, high efficiency, and rugged construction. However, PMSMs are nonlinear multivariable systems. Moreover, the model parameters can be changed by temperature and current, and the load torque is also widely unknown. Thus, it is difficult to achieve

high-performance speed or position control with linear control methods such as a PI control or an LQ regulator. Therefore, nonlinear control techniques can be a promising alternative to precisely control the PMSM.

Recently, many researchers presented various nonlinear control methods [1-9] to deal with the above problems by directly considering the nonlinear PMSM dynamics. In [3], a nonlinear backstepping control scheme has been proposed to control the speed of the PMSM. The most appealing point of that method is to use the virtual control variable to make the high-order system simple, and thus the final control outputs can be derived step-by-step through appropriate Lyapunov functions. However, this control scheme requires the exact model knowledge of the control system. The fuzzy techniques [4-6] and a sliding-mode control [7-9]

---

\* Main author : Division of Electronics and Electrical Engineering, Dongguk University-Seoul

\*\* Corresponding author : Division of Electronics and Electrical Engineering, Dongguk University-Seoul  
Tel : +82-2-2260-3348, Fax : +82-2-2275-0162  
E-mail : jinwjung@dongguk.edu  
Date of submit : 2010. 11. 30  
First assessment : 2010. 12. 3  
Completion of assessment : 2011. 1. 11

have also been reported for speed control of the PMSM. Although these control methods can obtain good performance, they are quite complex to be implemented. In [10–11] the authors have presented the feedback linearization techniques for designing the controller of nonlinear systems such as robot manipulators, induction motors, and PMSMs. In comparison with the others, the feedback linearization techniques are very useful methodologies for AC motor control. The controllers, which have been presented in [10–11], however, require full knowledge of the system parameters and load conditions with sufficient accuracy.

This paper proposes a nonlinear speed controller for PMSM. The controller consists of a nonlinear compensating term and a stabilizing term. The extended Kalman filter (EKF) observer is used for estimating the load torque which the proposed controller needs. To evaluate the performance of the proposed regulator, simulation and experimental results are presented in the presence of motor parameter variations with a prototype PMSM drive system.

## 2. Nonlinear Controller Design

### 2.1 PMSM model

Based on the  $d$ - $q$  reference theory, the stator voltage equations of a three-phase surface-mounted PMSM can be expressed as (1), and Fig. 1 illustrates the equivalent circuit of the PMSM.

$$\begin{aligned} V_{qs} &= R_s i_{qs} + L_s \frac{di_{qs}}{dt} + \omega L_s i_{ds} + \lambda_m \omega \\ V_{ds} &= R_s i_{ds} + L_s \frac{di_{ds}}{dt} - \omega L_s i_{qs} \end{aligned} \quad (1)$$

where  $R_s$  is the stator resistance,  $L_s$  is the stator

inductance,  $\omega$  is the electrical rotor angular speed,  $\lambda_m$  is the magnetic flux,  $i_{qs}$  is the  $q$ -axis current,  $i_{ds}$  is the  $d$ -axis current,  $V_{qs}$  is the  $q$ -axis voltage, and  $V_{ds}$  is the  $d$ -axis voltage, respectively.

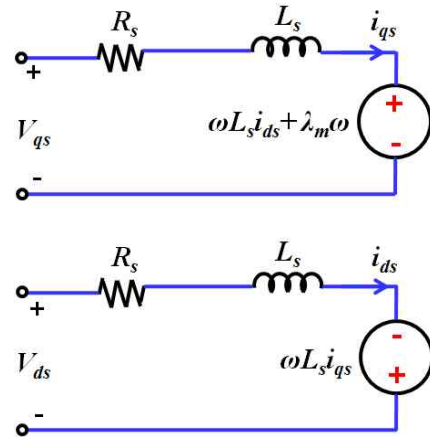

Fig. 1. PMSM equivalent circuit

Also, the electromagnetic torque ( $T_e$ ) can be given by

$$T_e = \frac{3}{2} \frac{p}{2} \lambda_m i_{qs} = \frac{2J}{p} \frac{d\omega}{dt} + \frac{2}{p} B\omega + T_L \quad (2)$$

where  $p$  is the number of poles,  $J$  is the rotor inertia,  $B$  is the viscous friction coefficient, and  $T_L$  is the load torque plus parameter imprecision, respectively.

From (1) and (2) the PMSM can be represented by the following differential equations:

$$\begin{aligned} \dot{\omega} &= k_1 i_{qs} - k_2 \omega - k_3 T_L \\ \dot{i}_{qs} &= -k_4 i_{qs} - k_5 \omega + k_6 V_{qs} - \omega i_{ds} \\ \dot{i}_{ds} &= -k_4 i_{ds} + k_6 V_{ds} + \omega i_{qs} \end{aligned} \quad (3)$$

where  $k_i > 0$ ,  $i = 1 \dots 6$  are the parameter values given by the nominal values of  $p$ ,  $R_s$ ,  $L_s$ ,  $J$ ,  $B$ , and  $\lambda_m$ , respectively.

## 2.2 Speed Regulator Design and Stability Analysis

In this paper, the following assumptions, which are widely used in most papers, will be made to design a nonlinear speed regulator:

A1:  $\theta$ ,  $i_{qs}$ ,  $i_{ds}$  are measurable.

A2: The load torque  $T_L$  is unknown and it changes very slowly, i.e.,  $\dot{T}_L$  can be set as 0.

A3: The desired rotor angular speed,  $\omega_d$ , is twice differentiable, and  $\omega_d, \dot{\omega}_d, \ddot{\omega}_d$  are bounded.

Next, let us define the rotor position error ( $\theta_e$ ), rotor speed error ( $\omega_e$ ) and rotor angular acceleration error ( $\eta_e$ ) as

$$\begin{aligned} \theta_e &= \int_0^t \omega_e d\tau = \int_0^t (\omega - \omega_d) d\tau \\ \omega_e &= \omega - \omega_d \\ \eta &= \dot{\omega}_e = k_1 i_{qs} - k_2 \omega - k_3 T_L \\ \eta_e &= \dot{\omega}_e = \dot{\omega} - \dot{\omega}_d = \eta - \dot{\omega}_d \end{aligned} \quad (4)$$

Let the control inputs  $V_{qs}$  and  $V_{ds}$  be defined as

$$\begin{aligned} V_{qs} &= \frac{1}{k_1 k_6} (u_{ffq} + u_{fbq}), \quad V_{ds} = \frac{1}{k_6} (u_{ffd} + u_{fbd}) \\ u_{ffq} &= \dot{\omega}_d + k_2 \eta + k_1 k_4 i_{qs} + k_1 k_5 \omega + k_1 \omega i_{ds} \\ u_{ffd} &= k_4 i_{ds} - \omega i_{qs} \end{aligned} \quad (5)$$

where  $u_{ffq}$  and  $u_{ffd}$  are the linearizing control terms used to compensate for the nonlinear characteristics of PMSM, and  $u_{fbq}$  and  $u_{fbd}$  are the feedback control terms used to stabilize the error dynamics.

Then, the model (3) can be transformed into the following:

$$\begin{aligned} \dot{\theta}_e &= \omega_e \\ \dot{\omega}_e &= \eta_e \\ \dot{\eta}_e &= u_{fbq} \\ \dot{i}_{ds} &= u_{fbd} \end{aligned} \quad (6)$$

The model (6) can be rewritten in the state-space form below.

$$\dot{x} = Ax + Bu \quad (7)$$

$$\text{where } A = \begin{bmatrix} 0 & 1 & 0 & 0 \\ 0 & 0 & 1 & 0 \\ 0 & 0 & 0 & 0 \\ 0 & 0 & 0 & 0 \end{bmatrix}, \quad B = \begin{bmatrix} 0 & 0 \\ 0 & 0 \\ 1 & 0 \\ 0 & 1 \end{bmatrix}, \quad x = \begin{bmatrix} \theta_e \\ \omega_e \\ \eta_e \\ i_{ds} \end{bmatrix}$$

$$u = \begin{bmatrix} u_{fbq} \\ u_{fbd} \end{bmatrix}.$$

By defining the feedback control terms ( $u_{fbq}$  and  $u_{fbd}$ ) as  $u_{fb} = [u_{fbq}, u_{fbd}]^T = Kx$ , the closed-loop control system can be expressed by:

$$\dot{x} = (A + BK)x \quad (8)$$

where  $K \in R^{2 \times 4}$  denotes the controller gain matrix.

Since the pair (A, B) can be stabilized, the standard results [12] imply the existence of a stabilizing gain,  $K$ , such that for some positive-definite matrix  $P_c$

$$P_c(A + BK) + (A + BK)^T P_c < 0 \quad (9)$$

Let us define the Lyapunov function as  $V_c = x^T P_c x$ . From the closed-loop system (8), its time derivative is written as

$$\dot{V}_c = \frac{d}{dt} x^T P_c x = 2x^T P_c [A + BK]x \leq 0 \quad (10)$$

The above equation (10) implies that the origin  $x = 0$  is exponentially stable. Therefore, the following Theorem 1 can be obtained.

*Theorem 1:* Consider the closed-loop control system of (3), (5), and  $u_{fb} = [u_{fbq}, u_{fbd}]^T = Kx$ . Assume that the gain matrix  $K$  stabilizes  $(A + BK)$ . Then,  $x$  exponentially converges to zero.

### 2.3 EKF-Based Load Torque Observer

The proposed nonlinear speed regulator needs the knowledge of the rotor angular acceleration ( $\eta$ ). As shown in (4), it can be easily obtained if the load torque is given. Accordingly, the control performance can be severely degraded if the term  $T_L$  is unknown. In this paper, an observer based on Extended Kalman filter (EKF) [13] is used to estimate the load torque because it is well-known that the EKF-based observer is insensitive to motor parameters and load torque variations, and can also suppress the measurement errors caused from the sensors [14].

From (2), the load torque observer can be represented as the following continuous-time state space equation:

$$\begin{aligned} \dot{x}_o &= A_o x_o + B_o u_o \\ y_o &= C_o x_o \\ \hat{T}_L &= C_T x_o \end{aligned} \tag{11}$$

where  $\hat{T}_L$  is an estimate of  $T_L$ , and

$$x_o = [\hat{\theta} \quad \hat{\omega} \quad \hat{T}_L]^T, \quad x_c = [\theta \quad \omega \quad T_L]^T, \quad u_o = T_e,$$

$$C_o = [1 \quad 0 \quad 0], \quad A_o = \begin{bmatrix} 0 & 1 & 0 \\ 0 & -\frac{p}{2}k_2 & -k_3 \\ 0 & 0 & 0 \end{bmatrix}, \quad B_o = \begin{bmatrix} 0 \\ k_3 \\ 0 \end{bmatrix},$$

$$C_T = [0 \quad 0 \quad 1].$$

By introducing an Euler approximation method, the approximate discrete-time model of the PMSM can be expressed as

$$\begin{aligned} x_o(k+1) &= A_{od}x_o(k) + B_{od}u_o(k) \\ y_o(k) &= C_o x_o(k) \\ \hat{T}_L(k) &= C_T x_o(k) \end{aligned} \tag{12}$$

where

$$A_{od} = \begin{bmatrix} T & T & 0 \\ 0 & T(1 - \frac{p}{2}k_2) & -Tk_3 \\ 0 & 0 & T \end{bmatrix}, \quad B_{od} = \begin{bmatrix} 0 \\ Tk_3 \\ 0 \end{bmatrix},$$

$T$  is the sampling time, and  $x_o(k)$ ,  $u_o(k)$ ,  $y_o(k)$  are the values of  $x_o$ ,  $u_o$ ,  $y_o$  at the sampling instant  $k$ .

Fig. 2 depicts an algorithm of the EKF-based load torque observer [13] used in this paper. It is noted that  $P$  is the error covariant matrix,  $L$  is the Kalman gain,  $Q$  and  $R$  are the noise covariance matrices,  $\bar{x}_o$  is the prediction of  $x_o$ ,  $\bar{P}$  is the prediction of  $P$ , and  $x_o(0)$  and  $P(0)$  are the initial values of  $x_o$  and  $P$ , respectively.

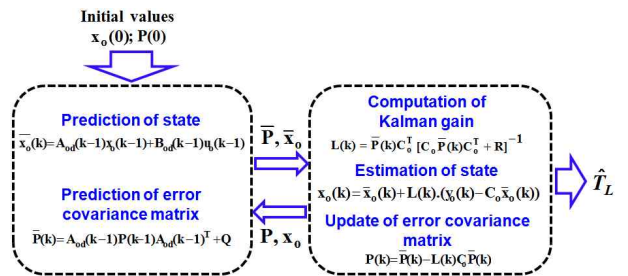

Fig. 2. Algorithm of EKF-based load torque observer

As shown in Fig. 2, the EKF algorithm to estimate the load torque consists of two steps. The

first step performs the prediction of two quantities  $(\bar{x}_o(k), \bar{P}(k))$  based on the previous estimates. That is, the predicted value  $\bar{x}_o(k)$  is calculated from the previous state  $x_o(k-1)$  and previous input  $u_o(k-1)$ , and the predicted value  $\bar{P}(k)$  is derived from the previous error covariant matrix  $P(k-1)$  and noise covariance matrix  $Q$ . In the second step, the Kalman gain  $L(k)$  is computed by using  $\bar{P}(k)$  and  $R$ , and then the state  $x_o(k)$  is estimated with  $L(k)$  and  $\bar{x}_o(k)$ . Also,  $P(k)$  is updated for the next calculation using  $\bar{P}(k)$  and  $L(k)$ . Finally, the estimated load torque  $(\hat{T}_L)$  can be obtained from  $x_o$  and  $C_T$ .

### 3. Simulations and Experiments

To confirm the effectiveness of the proposed nonlinear speed controller, simulations and experiments are performed. Table 1 shows the nominal parameters of a prototype PMSM considered in this paper. According to the parameters shown in Table 1, the dynamic equations can be rewritten as follows:

$$\begin{aligned} \dot{\omega} &= 3539.6i_{qs} - 0.2484\omega - 4968.8T_L \\ \dot{i}_{qs} &= -170.1i_{qs} - 13.6\omega + 171.8V_{qs} - \omega i_{ds} \\ \dot{i}_{ds} &= -170.1i_{ds} + 171.8V_{ds} + \omega i_{qs} \end{aligned} \quad (13)$$

Table 1. Specifications of PMSM

Number of poles ( $p$ )	12
Stator resistance ( $R_s$ )	0.99[Ω]
Stator inductance ( $L_s$ )	5.82[mH]
Magnetic flux ( $\lambda_m$ )	0.0792[V·sec/rad]
Equivalent inertia ( $J$ )	0.0012[kg.m <sup>2</sup> ]
Viscous friction coefficient ( $B$ )	0.0003[N·m·sec/rad]

To design the EKF-based load torque observer,

the following matrices are chosen:

$$\begin{aligned} A_{od} &= \begin{bmatrix} T & T & 0 \\ 0 & -0.49T & -4968.8T \\ 0 & 0 & T \end{bmatrix}, B_{od} = \begin{bmatrix} 0 \\ 4968.8T \\ 0 \end{bmatrix}, \\ x_o(0) &= \begin{bmatrix} 0 \\ 0 \\ 0 \end{bmatrix}, P(0) = \begin{bmatrix} 2 & 0 & 0 \\ 0 & 2 & -0.01 \\ 0 & -0.01 & 2 \end{bmatrix}, \\ Q &= 5 \times 10^{-6} \begin{bmatrix} 1 & 0 & 0 \\ 0 & 1 & 0 \\ 0 & 0 & 1 \end{bmatrix}, R = 0.001. \end{aligned}$$

From the EKF algorithm shown in Fig. 2, the Kalman gain  $L$  is below calculated with respect to time.

$$L(k) = \bar{P}(k)C_o^T [C_o\bar{P}(k)C_o^T + R]^{-1}$$

Next, the observer-based feedback control terms can be expressed as

$$u_{fb} = [u_{fbq} \quad u_{fbd}]^T = K\hat{x} \quad (14)$$

$$\begin{aligned} \text{where } \hat{x} &= [\theta_e, \omega_e, \hat{\eta}_e, i_{ds}]^T, \quad \hat{\eta} = \hat{\omega} = k_1 i_{qs} - k_2 \omega - k_3 \hat{T}_L, \\ \hat{\eta}_e &= \hat{\omega}_e = \hat{\eta} - \hat{\omega}_d. \end{aligned}$$

Finally, the following controller gain is used:

$$K = 10^8 \times \begin{bmatrix} -5.2006 & -0.0194 & 0 & 0 \\ 0 & 0 & 0 & 0 \end{bmatrix}$$

Fig. 3 shows a block diagram of the observer-based speed controller. Based on Fig. 3, simulations and experiments are executed to evaluate the performance of the proposed control

algorithm. Fig. 4 shows an overall block diagram of the proposed nonlinear control system. In this paper, a space vector PWM (SVPWM) technique is used due to well-known benefits, and PWM frequency and sampling frequency ( $1/T$ ) are selected as 5 [kHz] considering switching loss and current ripple.

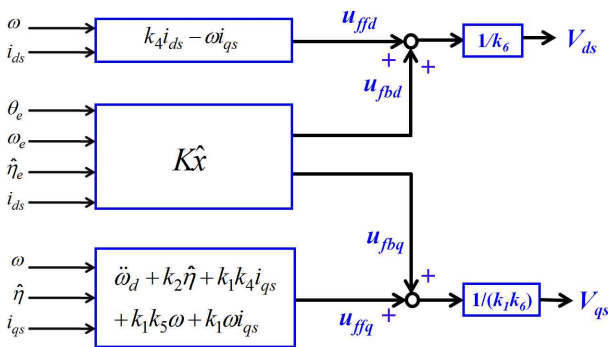

Fig. 3. Block diagram of the observer-based speed controller

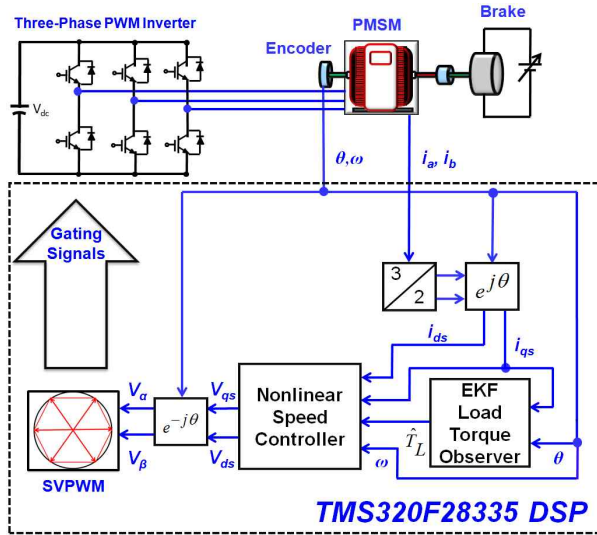

Fig. 4. Overall block diagram of the proposed nonlinear control system

Fig. 5 and 6 show the simulation results of two conditions (nominal parameters and 200[%] variations of some system parameters) by using Matlab/Simulink. In this case, the motor desired

speed ( $\omega_d$ ) increases from 157.08[rad/sec] to 314.16 [rad/sec] and then decreases to 157.08[rad/sec]. Fig. 5 shows the simulation results ( $\omega_d, \omega, \omega_e, T_L, \hat{T}_L, i_{qs}, i_{ds}, V_{\alpha\beta}, i_a$ ) under nominal parameters. On the other hand, Fig. 6 shows the simulation results under 200[%] variations of some parameters ( $R_s, L_s, J$ ) to verify the robustness of the proposed control scheme. In Fig. 6, the proposed nonlinear speed controller shows good control performance under even model parameter variations.

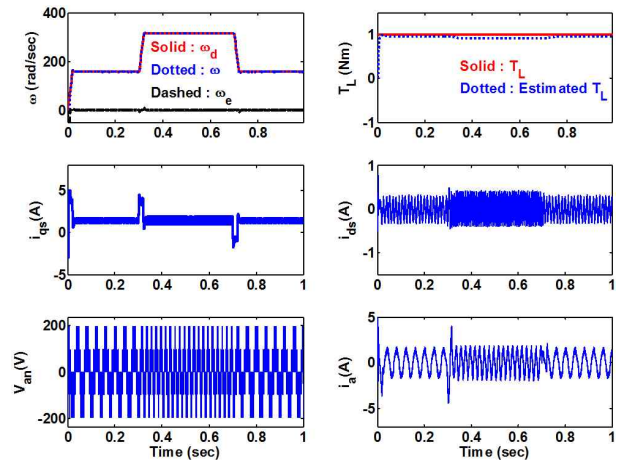

Fig. 5. Simulation results under nominal parameters

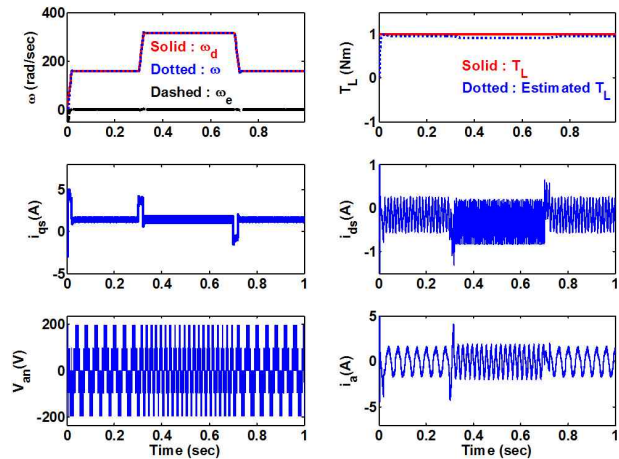

Fig. 6. Simulation results under 200[%] variations of some system parameters ( $R_s, L_s, J$ )



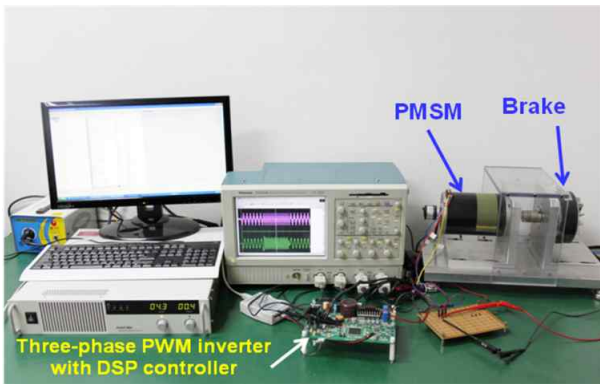

Fig. 7. Experimental setup

Fig. 7 illustrates the experimental test setup to implement the proposed control algorithm. As shown in Fig. 7, it includes a PMSM, a brake, a host PC, a three-phase PWM inverter with a TMS320F28335 DSP. Fig. 8 shows the experimental results under the same conditions as Fig. 5, whereas Fig. 9 shows the experimental results under the same condition as Fig. 6. Fig. 8 (a) and 9 (a) show the desired speed ( $\omega_d$ ), measured speed ( $\omega$ ), and speed error ( $\omega_e$ ). Fig. 8 (b) and 9 (b) show the load torque ( $T_L$ ) and estimated load torque ( $\hat{T}_L$ ). Fig. 8

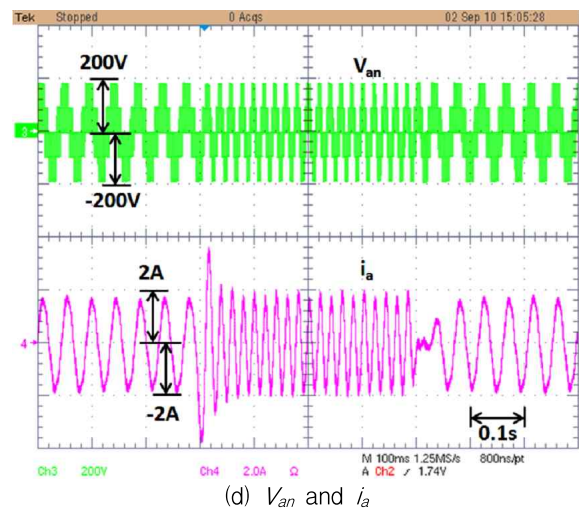
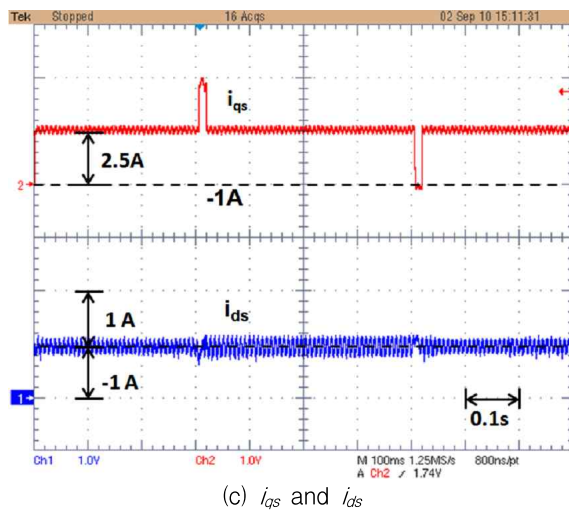
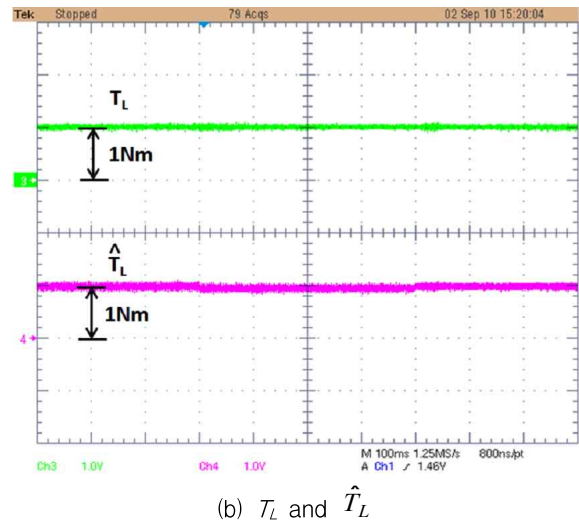
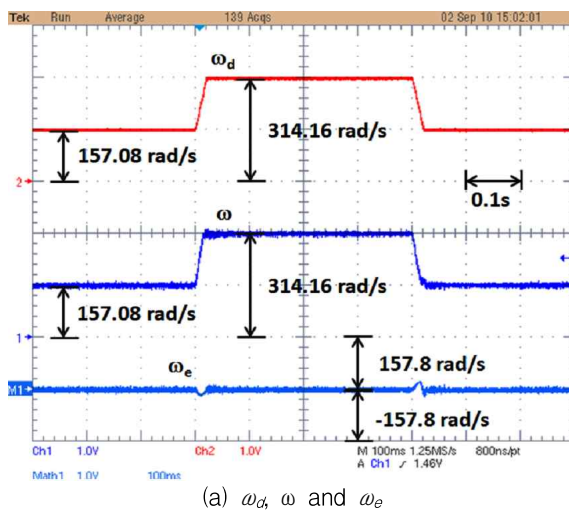

Fig. 8. Experimental results under nominal parameters

(c) and 9 (c) show the measured  $q$ -axis current ( $i_{qs}$ ) and  $d$ -axis current ( $i_{ds}$ ). Fig. 8 (d) and 9 (d) show the phase a voltage ( $V_{an}$ ) and phase a current ( $i_a$ ).

From simulation and experimental results, it is shown that actual motor speed reaches the desired speed within about 10[msec], and the steady-state speed error is almost zero. Therefore, it is clearly realized that the proposed control scheme can accurately and quickly follow the reference trajectory of a PMSM in the presence of motor

parameter variations.

### 4. Conclusion

This paper presented a nonlinear control scheme for PMSM drive systems. In this paper, an extended Kalman filter (EKF) observer was employed to estimate the load torque. Through the simulation and experimental results, it was verified that the proposed control method can precisely and rapidly

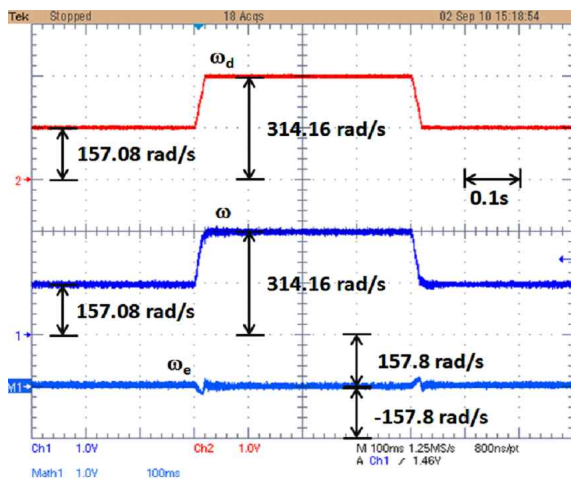

(a)  $\omega_d$ ,  $\omega$  and  $\omega_e$

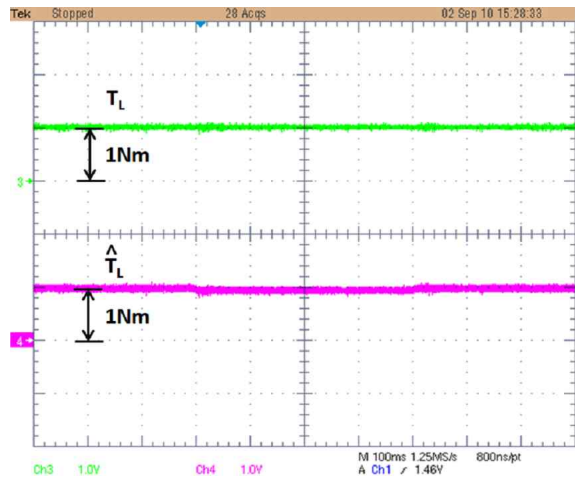

(b)  $T_L$  and  $\hat{T}_L$

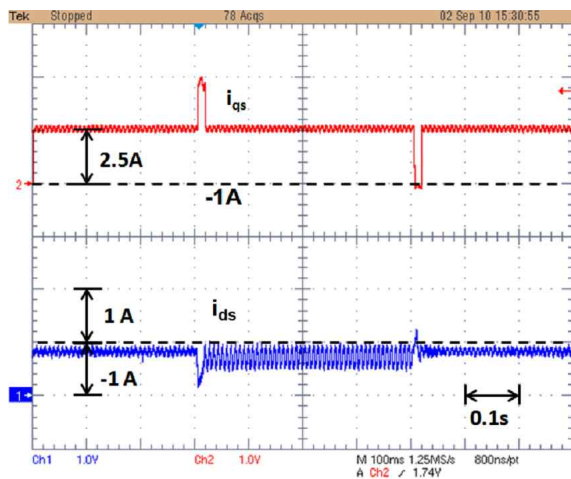

(c)  $i_{qs}$  and  $i_{ds}$

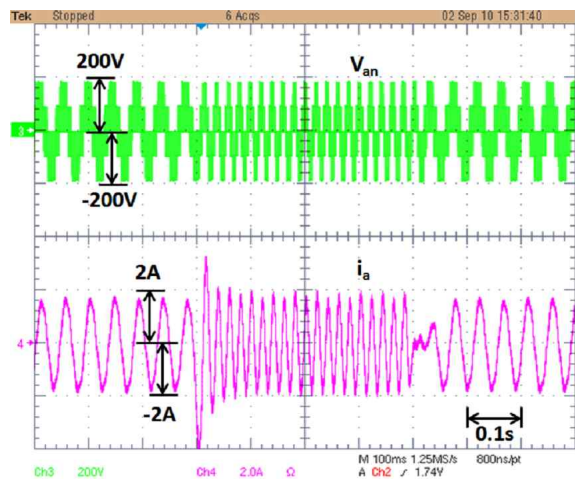

(d)  $V_{an}$  and  $i_a$

Fig. 9. Experimental results under 200[%] variations of some parameters ( $R_s$ ,  $L_s$ ,  $J$ )



track the desired speed even under the variations of motor parameters and unknown load torque conditions.

This research was supported by Basic Science Research Program through the National Research Foundation of Korea (NRF) funded by the Ministry of Education, Science and Technology (No. 2010-0009577).

## References

- [1] M. Boussak, "Implementation and experimental investigation of sensorless speed control with initial rotor position estimation for interior permanent magnet synchronous motor drive," *IEEE Trans. on Power Electronics*, Vol. 20, No. 6, pp. 1413-1422, Nov. 2005.
- [2] M.A. Rahman, D.M. Vilathgamuwa, M.N. Uddin, and K.J. Tseng, "Nonlinear control of interior permanent magnet synchronous motor," *IEEE Trans. on Industry Applications*, Vol. 39, No. 2, pp. 408-416, Apr. 2003.
- [3] J. Zhou and Y. Wang, "Adaptive backstepping speed controller design for a permanent magnet synchronous motor," *IEE Proceedings Electric Power Applications*, Vol. 149, No. 2, pp. 165-172, Mar. 2002.
- [4] A.V. Sant and K.R. Rajagopal, "PM Synchronous Motor speed control using hybrid fuzzy-PI with novel switching functions," *IEEE Trans. on Magnetics*, Vol. 45, No. 10, pp. 4672-4675, Oct. 2009.
- [5] E. Kim and S. Lee, "Output feedback tracking control of MIMO systems using a fuzzy disturbance observer and its application to the speed control of a PM Synchronous Motor," *IEEE Trans. on Fuzzy Systems*, Vol. 13, No. 6, pp. 724-741, Dec. 2005.
- [6] K.Y. Cheng and Y.Y. Tzou, "Fuzzy optimization techniques applied to the design of a digital PMSM servo drive," *IEEE Trans. on Power Electronics*, Vol. 19, No. 4, pp. 1085-1099, July 2004.
- [7] A.R. Ghafari-Kashani, J. Faiz, and M.J. Yazdanpanah, "Integration of non-linear  $H^\infty$  and sliding mode control techniques for motion control of a permanent magnet synchronous motor," *IET Electric Power Applications*, Vol. 4, No. 4, pp. 267-280, 2010.
- [8] C.K. Lai, and K.K. Shyu, "A novel motor drive design for incremental motion system via sliding-mode control method," *IEEE Trans. on Industrial Electronics*, Vol. 52, No. 2, pp. 499-507, Apr. 2005.
- [9] I.C. Baik, K.H. Kim, and M.J. Youn, "Robust nonlinear speed control of PM synchronous motor using boundary layer integral sliding mode control technique," *IEEE Trans. on Control Systems Technology*, Vol. 8, No. 1, pp. 47 - 54, Jan. 2000.

- [10] J.J.E. Slotine and W. Li, *Applied Nonlinear Control*, Englewood Cliffs, NJ: Prentice-Hall, 1991.
- [11] T. von Raumer, J.M. Dion, L. Dugard, and J.L. Thomas, "Applied nonlinear control of an induction motor using digital signal processing," *IEEE Trans. on Control Systems Technology*, Vol. 2, No. 4, pp. 327 - 335, Dec. 1994.
- [12] S. Boyd, L. El Ghaoui, E. Feron, and V. Balakrishnan, "Linear Matrix Inequalities in System and Control Theory," SIAM, Philadelphia. 1994.
- [13] Z. Zheng, Y. Li, M. Fadel, and X. Xi, "A Rotor Speed and Load Torque Observer for PMSM Based on Extended Kalman Filter," *IEEE International Conference on Industrial Technology, ICT*, pp. 233 - 238, Dec. 2006.
- [14] G. Bishop and G. Welch, "An Introduction to the Kalman Filter," *SIGGRAPH 2001 Course Notes*, Citeseer, 2001.

## Biography



### Nga Thi-Thuy Vu

Nga Thi-Thuy Vu was born in Vietnam in 1982. She received B.S. and M.S. degrees in Electrical Engineering from Hanoi University of Technology, Hanoi, Vietnam in 2005 and 2008, respectively. She is currently pursuing a Ph.D in the Division of Electronics and Electrical Engineering, Dongguk University, Seoul, Korea. Her research interests are in the field of DSP-based electric machine drives and control of distributed generation systems using renewable energy sources.



### Jin-Woo Jung

Jin-Woo Jung was born in Korea in 1969. He received B.S. and M.S. degrees in Electrical Engineering from Hanyang University, Seoul, Korea in 1991 and 1997, respectively, and a Ph.D. in Electrical and Computer Engineering from Ohio State University, Columbus, Ohio, USA, in 2005. From 1997 to 2000, he was with the Digital Appliance Research Laboratory, LG Electronics Co., Ltd., Seoul, Korea. From 2005 to 2008, he worked at the R&D Center and PDP Development Team, Samsung SDI Co., Ltd., Korea, as a senior engineer. Since 2008, he has been an Assistant Professor with the Division of Electronics and Electrical Engineering, Dongguk University, Seoul, Korea. His current research interests are in the areas of DSP-based electric machine drives, control of distributed generation systems using renewable energy sources (wind turbines, fuel cells, solar cells), design and control of power converters, driving circuits and driving methods of ac plasma display panels (PDP).