

A Study on System Development for Ship's Integrated Safety and Security

† Daegwun Yoon · Cheol-Seung Kim*

†, * Department of Maritime Transportation, Mokpo Maritime University, Mokpo 530-729, Republic of Korea

Abstract : *As the faithful performance of ISPS of IMO, nowadays actually applicable an integrated safety and security system in and out of vessel should be organized in views of seafarers. Therefore, this paper is aimed to design a fundamental system for ship's integrated safety and security. The system of integrated grabbing will affect efficiently in any maritime field of material and human flow. Therefore this research will be expected to affect economical side by securing all the risk of maritime issues. In addition to the passenger ship and merchant vessel, it is applicable to other public and private vessels either. As a result of this paper, the system designed collecting various data through integrating the system including RFID reader, PIR sensor, and CMOS camera by putting an individual number into each unit that could be control at easy.*

Key words : *safety, security, ship, integrated system, design*

1. Introduction

Currently, in Jeonnam, especially islands around, Mokpo Ferry terminal is annually transporting the passenger (about 1million) to 80 islands. It is predicted that this research enable to control illegal boarding party on board including working conditions of watch keeper, and various safety and security zone control[DHS, 2007]. Currently, internationally, in case of ship and port facility, International maritime organization (IMO) is asking of enhanced security about passenger and crew who are passing the facility and bridge resources including crew, equipment, but they do not have any plan about this situation, and in case of Korea, though many life/ship's safety accident are happened steadily, scientific safety and security system is not exist [Sollenberger, 2004]. In order to ensure the safety of maritime passenger[John, 2005], It needs to have software system about near risk factors checking, level of risk determination, crisis response and the hardware system(equipped with other devices and sensors) that they can automatically detect the danger, In this research process, ship's safety and security system with the initial research phase, they find out the actual condition of the passenger transport in southwest coast of Korea through a survey, and uncover the appropriate safety and security

system form for ship's working safety management[Peter, 2009], they developed the ship's safety and security system's initial model[Lee, 2010]. In order to set for new security system, this research was conducted because recently several security issues were occurred in the war ship through commercial vessel such as Cheonan-Ham and Samho Dream-Ho. The aim of this paper is to design security system diagram within the vessel in terms of fixed and portable type. The both types describe working flow including server, moving unit, RFID reader, CMOS camera, micro-processor, and communication module so forth. Regarding device specifications to being installation in this system design, embedded system, RFID reader, PIR sensor, CMOS camera, communication module, SMPS, rechargeable battery, battery recharger were used for the test of the system. Finally, in this paper, management software between fixed and/or portable device, RFID card reading and writing function, and RFID card management are functioning into the system design in terms of faithful performance of ISPS of IMO. As an effect of this research, integrated grabbing system (IGS) developed by this research, especially passenger vessel, navy and coast guard, needs to deploy this system in order to secure the safety of public and privacy facilities and humanity.

† Corresponding author, dyoon@mmu.ac.kr 061)240-7179

* cskim@mmu.ac.kr (061)240-7174

Note) This paper was presented on the subject of "System Design for Ship's Integrated Safety and Security" in 2010 Asia Navigation Conference proceedings(Songdo, Incheon, 4th Nov-6th Nov, 2010, pp.279-283)

2. Questionnaire and Database

2.1 Questionnaire Area

2.1.1 Range

Currently, West-south islands of Korea, Mokpo Ferry terminal is annually transporting the passenger (about 1million in year) to 80 islands including Jeju island, Shinan(Anjwa, Palgum), Jindo(Jindo Jodo) through many coastal liners. In southwest coast, because of fast current and severe tide, they have much difficulty in searching the missed people because they moved other position by fast current and get buried to mud when people fall in the sea. In case of these marine missing accidents, they are focusing on 10 days rescue working that 4~5 patrol boats are positioned to accidental sea, but, in case of the nature of the southwest coast, they have difficulty in searching the missed people.

Therefore, this research was preparing the integrated safety and security system model that minimize the passenger's inconvenience by delay in embarkation/disembarkation and privacy protecting problem about crew and passenger who are using the west-south terminal and ship

2.1.2 Area

Through accommodation ladder, access to enclosed space and ship's special facilities are important facility that certified person can only enter in designated hour(such as Cargo Hold, Boatswain Store, Deck Store, Bridge, Engine Room, Restricted Area, Deck House, Accommodation Area). Original detecting way of entering, it has problems that cause to happen crew's severe working stress because they are working with 1passage opening, the paper signature scheme, simple deck watch keeping, locking door according to busy sailing schedule, busy working schedule by ship's crew downsizing. Also, much problems are exist in sailing with risk situation because they cannot know any activity though person is illegally boarding the ship for impure purpose or installing the explosives or piracy activity. And, it is rule that workers have to make "permit and work instruction for confined spaces" in order to work in ship's confined space work, But, it has problem because there are no safety assistance equipments, so it cause to life accident when human error is happened. Also, it has difficulty in reverse tracing about missing time because it is not easily found people's missing in sailing. And it has difficulty in

obtaining the information about missing time and it has restriction in proving the reason about missing objectively. So, it needs to develop the ship's security and safety detecting system's special model in order to solve the restriction.

2.2 Database

We conducted a survey to west-southern terminal and crew/passenger who are using the vessel for constructing integrated safety and security system model that minimize passenger's inconvenience by privacy problem and embarkation/disembarkation delay. And, we collected important information through survey for detailed safety and security system model set-up.

- The result of research on the actual using condition in age about west-southern region 256 responders, it includes 70% in total passenger(thirties-fifties), according to using frequency, it is high that 25% passenger who are expected as island residents. But, it is real situation that most of passengers are using the passenger ship 3 times annually for tourism or business.

Table 1 Table of responders age

	Twenty	Thirty	Forty	Fifty	Sixty	Non-respond
Respondents (number of response)	5	20	47	36	12	9
Percentage (%)	12.2	24.3	28.7	22.0	7.3	5.5

Fig. 1 shows frequency of on-board per specific period. Main purpose of passenger ship onboard is for tourism and island residents described in Fig. 2

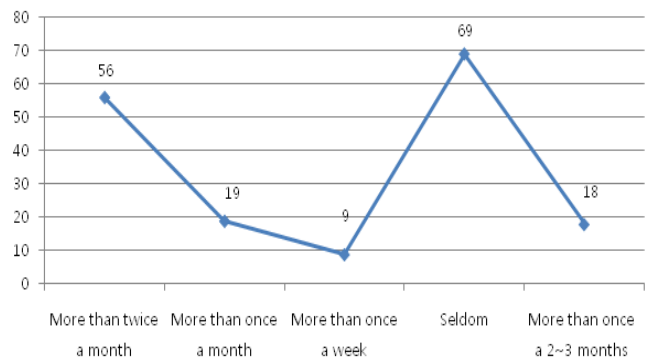

Fig. 1 Frequency of On-board

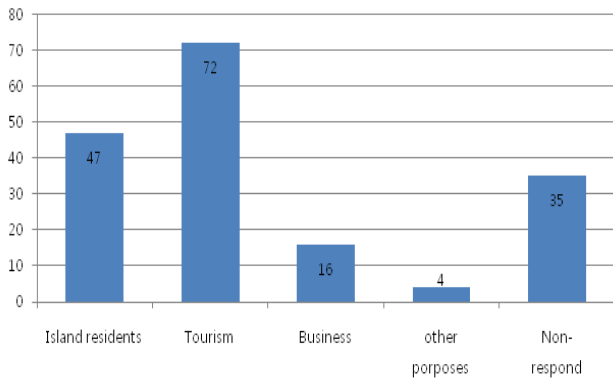

Fig. 2 Purpose of Ship On-board

For the end of accident that is likely happened on the ship, they responded that missing and emergency patient situation's happening are very dangerous. In addition, there are many responses about danger by unidentified person's random embarkation/disembarkation and illegal entering to restricted area.

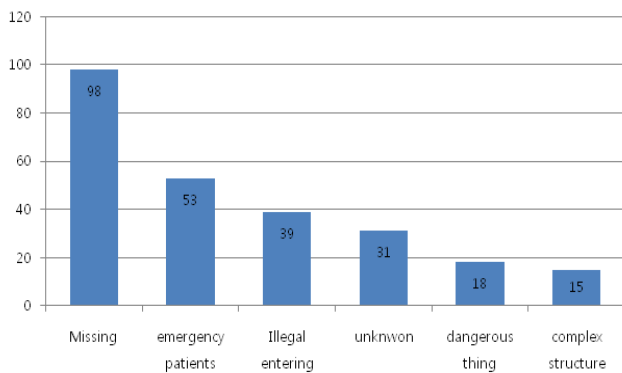

Fig. 3 Purpose of security device install

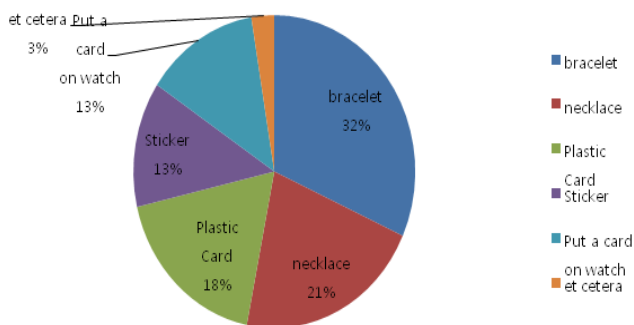

Fig. 4 Preference of security-awareness device form

If people must have device individually for passenger and crew's safety checking in sailing, about the most convenient form for the recognition devices, it is shown that people give preference to bracelet, necklace, plastic card in order of

age. So people give preference to security bracelet that it can use easily at site. If security surveillance device for ship's safety is installed, in questions about appropriate position, they evenly answered various pathways, ship railing, bedrooms and engine room in order of age. And, it can understand that it need to have generally integrated management about ship's security and safety in whole area.

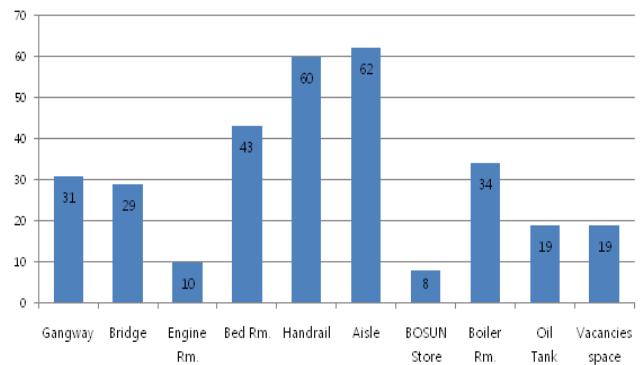

Fig. 5 Security surveillance equipment install zone

More than 62% respondents answered that it need to ship's security facility for managing the ship and passenger's safety such as ship's safety accident, missing, restricted area restriction for using the ship, using the terminal or proceeding the passenger ship. It needs to construct not only passenger ship's passenger but also owner's safety and security management system.

Table 2 Maturity grid

	Certainty	Wisdom	Enlightenment	Awakening	Uncertainty
Opinion for security device install	be positively necessary	convenience	same as at present	in-convenience	needlessness
Attitude of personal information opening	all kinds of information	including a biometric data	same as at present	except a register number	off the record

Table 3 Opinion for security device install

	Certainty	Wisdom	Enlightenment	Awakening	Uncertainty
Respondents (Number of response)	97	61	35	48	23
Percentage (%)	38.3	23.8	14.1	19.7	8.3

If people disclose private information for safety in sailing, in questions about level of disclosing the information, more than 70% respondents want to disclose only embarkation/disembarkation venue, name, resident registration number level.

Table 4 Attitude of personal information opening

	Certainty	Wisdom	Enlightenment	Awakening	Un-certainty
Respondents (Number of response)	97	61	35	48	23
Percentage (%)	38.3	23.8	14.1	19.7	8.3

3. System Diagram and Device Specifications for Security Design within the Ship

3.1 General Discussion for Security Required in the Ship

The people through by the accommodation ladder between ship and shore, deck house, accommodation area, restricted area, engine room, bridge, deck store, boatswain store, cargo hold should be inspected and checked with the security purpose in all the critical points of vessel.

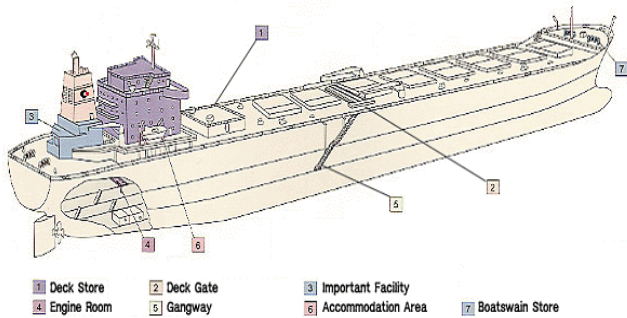

Fig. 6 Vessel's critical point

3.2 System Diagram

The paper is kindly requested to address fixed and portable type of gear, development of ID card, management software, expected effect and remind. Before addressing those type, detail specification of RFID reader and chip is as follows.

1) RFID Chip

- Protocol : EPC Class1 Gen2 Type Tag
- Operation Frequency : 886~928MHz
- Read Range : 3M

- Memory : Read/Write
- Size : 54 * 86mm
- Operation Temperature : -20~70°C

2) RFID Reader

- Frequency : 917~923.5MHz(Korea)
- Output Power : 1W max
- Operation Voltage : 5V+-0.5V
- Operation Current : 1.4A max
- RF Output Port : 2 Ports
- RF Output connector : 50Ω MMCX Female
- Reading Distance Range : 2.5 at Ant. 6dBic
- Writing Distance Range : 1M at Ant. 6dBic
- Protocol : EPC C1 GEN2
- Interface : RS232C
- Operation Temperature : -20~60°C
- Operation Humidity : 0~90%
- Dimension : 73 * 42 * 7.5mm
- Weight : 43g

Communication method of the system from RFID Card to RFID Reader is between wireless 917MHz and 924.5MHz, from RFID reader to embedded System for RS-232 115,200bps, and embedded system to server for RS-232 500,000bps.

3.2.1 Fixed Type

Usually, the fixed type of gear will be installed in the main gate of the vessel. The system of the fixed type includes memory into embedded system such as RFID Reader, PIR Sensor, CMOS Camera.

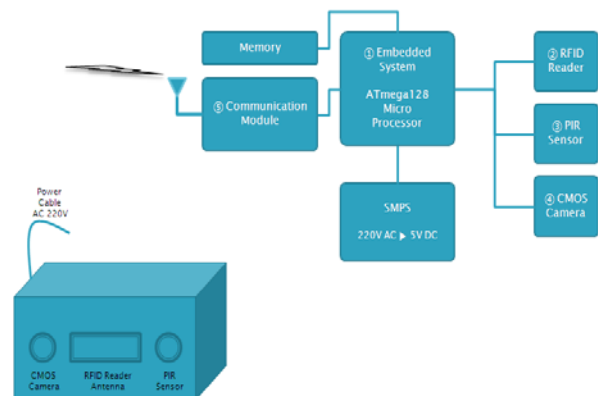

Fig. 7 Fixed type of the system

3.2.2 Portable Type

The portable type of gear is requested to aim at the establishment of the safety management system at sea in

the all around of the vessel except main gate or high security required places.

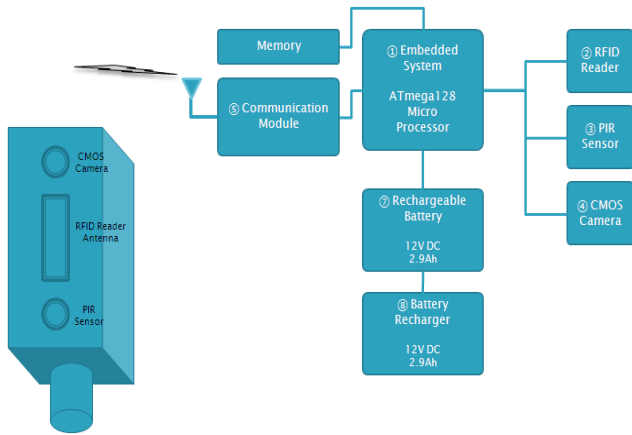

Fig. 8 Portable type of the system

3.3 Development of Identification Card

In order to check the level of character of human being who are entering into or out of vessel, the identification card should be classified. The card manufactured by putting RFID chip into the inner side of that.

3.4 Management Designed System

By settling the system down in the port terminal and vessel, the effect and applicable plan to be expended as follows.

- Support the problem of current in surveillance
- Work productivity increased
- Proper information for prevention and analysis of incident
- Illegal alien and terror possibility, and keeping pirate off
- Valuable information acquisition by the recorded data
- Check for not permitted human being
- Restricted area control
- However, privacy security for the applying the integrated system

Construction of integrated vessel security and safety monitoring system is able to indispensable system. As a result of the actual condition of the passenger transportation in south west coast, for building the construction of integrated vessel security and safety monitoring system that have an important thing before mentioned, but all passengers and owners fully realized necessity of the construction of integrated vessel security and safety monitoring system for ship's safety navigation and security.

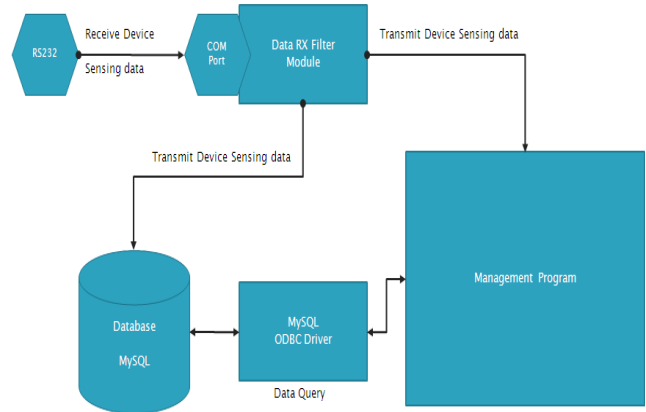

Fig. 9 Management flow for designed system

There are so many answers, dangerous facts which needed the security monitoring system are the accident that misdeed or disappearance, emergency patient and entrance and exit without duty in limited area. The area where will need to install the security monitoring device is the passage in the vessel, bulwark and each cabin and that is to imply that the integrated vessel management within all areas in the vessel will make effective security and safety monitoring system. Though this research, we were able to confirm the necessity of the construction of security and safety monitoring system for coastal passenger ship which has been navigating permanently. Without security performance, from now, the technical development of the security and safety monitoring system based on the place where be equipped with security and safety device when the vessel is sailing on the sea and the information in identification device's type will be necessary.

4. Differentiation and Test Result for the System

Previous and other system is only reading the RFID chip that is very vulnerable and weak, and needs to be very high cost required in order to cover safety and security system. However, this system designed is applicable system combining all equipment and facility of safety and security including RFID reader, PIR sensor, and CMOS camera which has effect on reduction of cost for safety and security. There are high possibility to enter the ship, therefore this system allows to protect all approach illegally into the ship by detecting those coming in. This system can be workable at time warning in terms of time limit in specific space, room and tank. So, even if someone who is qualified into the space, room and tank is coming in, the approached cannot be avoid from warning. As described in

previous chapter, the system can work on not only collecting data from RFID chip but extracting information from other auxiliaries including RFID reader, PIR sensor, and CMOS camera. Those information will be automatically recorded on a log which is easy to applicable to other unit kits. Fig. 10 shows the above system management program. In addition, the system has special setting function for both fixed type and portable type with individual ID. After collecting data and information, all should transmit to server system. At same time, based on the setting value, the system can be shown one of three mode, safety, warn, and reject.

ship, some other public vessel including navy armed vessel and coast guard need to the fixed and portable type of the system. Finally, the system studied in this research has effect on ship's safety and security by integrating all the human, material flow data and information.

References

- [1] Department of Homeland Security (2007), Report Of The DHS National Small Vessel Security Summit, pp.1-14.
- [2] Dillingham, G. L.(2003), TRANSPORTATION SECURITY Post-September 11th Initiatives and Long-Term Challenges, United States General Accounting Office, GAO-03-616T. pp.23-67
- [3] Frittelli, J.(2005), Transportation Security: Issues for the 109th Congress, Order Code IB10135. pp.1-25
- [4] Heathcote1, P.(2009), New Measures for Maritime Security Aboard Ships and in Port Facilities, Regional Maritime Legal Advisor Secretariat of the Pacific Community Suva, Fiji Islands. pp. 35-68
- [5] Korean Register of Shipping Materials and Equipment Team, GUIDANCE NOTE FOR SHIP SECURITY ALERT SYSTEM (SSAS), METGN-0001-04. pp. 46-49
- [6] Lee, J. W. et.al(2010), A Study on Logistics Security Recognition of Domestic Logistics Enterprises, Journal of Navigation and Port Research, Vol.34, No.1. pp.45-50
- [7] Marinerthai(2010), http://www.marinerthai.com/marinelaw/ShipSecurityPlan_ISPSCode.pdf
- [8] Sollenberger, M. A.(2004), Sensitive Security Information (SSI) and Transportation Security: Background and Controversies, CRS Report for Congress, Order Code RS21727. pp. 12-48

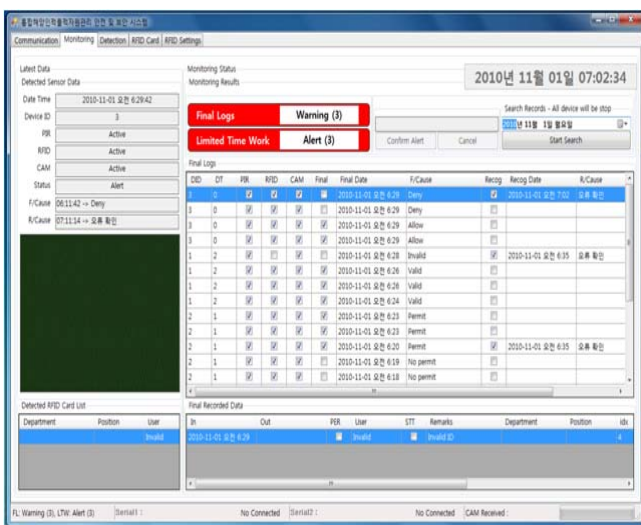

Fig. 10 Management program of the server system

Finally, there was an interference between RFID reader and PIR sensor which is needed to resolve by development of moving detection sensor.

5. Conclusion

As above described, the system designed is collecting various data through integrating the system including RFID reader, PIR sensor, and CMOS camera by putting an individual number into each unit that could be controlled with easy. This paper aimed to design a fundamental system for ship's integrated safety and security. Integrated grabbing system developed by this research is applicable into the port terminal and ships especially passenger vessel and public ship. This system and gear will bear huge economical effect in the port and vessel management by protecting illegal material and humanity entering and approaching into the facility. In addition to the passenger

Received 21 February 2011

Revised 27 March 2011

Accepted 28 March 2011