

Feedback Analysis of Transcutaneous Energy Transmission with a Variable Load Parameter

Tianliang Yang, Chunyu Zhao, and Dayue Chen

The transcutaneous energy transmission system (TETS) composed of a Class-E amplifier may operate at a state away from the optimum power transmission due to the load variation. By introducing the feedback-loop technique, the TETS can keep the optimum state with constant output voltage by adjusting the important design parameters, that is, the duty ratio and frequency of the driving signal and the supply voltage. The relations between these adjusted parameters and the load are investigated. The effectiveness of the feedback technique is validated through a design example with a variable load parameter. The experimental results show that the Class-E amplifier in the feedback loop can keep operating at the optimum state under the condition of up to 50 percent variation of the load value.

Keywords: Transcutaneous energy transmission system (TETS), Class-E amplifier, feedback systems, efficiency.

I. Introduction

The transcutaneous energy transmission system (TETS) with a Class-E amplifier is commonly used for the wireless powering system in the implanted electronic devices. The efficiency of the powering system is of critical importance due to the possibility of the tissue damage caused by overheating. However, this efficiency may become poor, and the output voltage may change due to load variations caused by the operating state of the implanted devices or the charging state of the implanted battery.

Much effort has been invested in reducing the efficiency decline by such methods as adjusting the frequency of the driving signal [1]-[3], or compensating the transmitting coil with an electrically controllable inductance [4], maintaining the output voltage constant by adapting the compensation capacitor [5], or by controlling the supply voltage with the receive data [6]. However, analytical expressions of the feedback control rules for the Class-E amplifier are not presented, and the Class-E amplifier may not operate in the optimum state [7]-[9] by only adjusting the frequency or the duty ratio of the driving signal when the load parameter changes. Therefore, the efficiency may not be the best. Adjusting the supply voltage may keep the output voltage constant when the load parameter changes, but this cannot maintain the optimum state of the TETS.

In this paper, we present an optimal design methodology for the TETS driven by a Class-E amplifier. Analytical expression for each component was derived at any duty ratio, and then a design example was designed and analyzed. The duty ratio, the frequency, and the supply voltage, which are adjusted to keep the TETS operating at the optimum state with a constant output voltage with respect to the load parameter, were derived. A

Manuscript received Sept. 20, 2009; revised Feb. 24, 2010; accepted Apr. 29, 2010.

This work was supported by the National Natural Science Foundation of China (No.60271031).

Tianliang Yang (phone: +86 21 34202725, email: tlyang@sjtu.edu.cn), Chunyu Zhao (email: zhaocy@sjtu.edu.cn), and Dayue Chen (dychen@sjtu.edu.cn) are with the Department of Instrument Science and Technology, Shanghai Jiao Tong University, Shanghai, China.
doi:10.4210/etrij.10.0109.0553

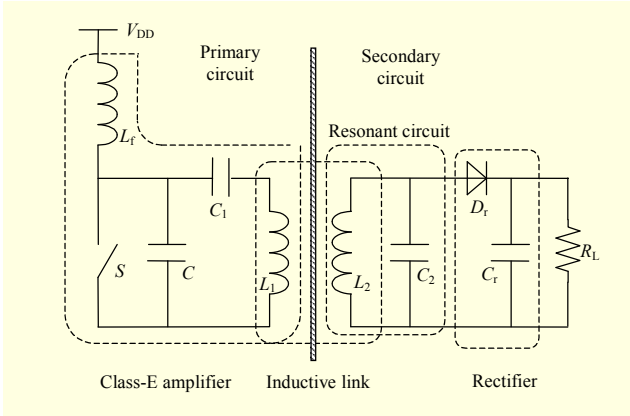

Fig. 1. Schematic diagram of the transcutaneous energy transmission with a Class-E power amplifier.

design example was constructed to validate the expressions.

II. Circuit Description

A schematic diagram of the simplified model of a typical TETS is shown in Fig. 1. This model consists of a primary circuit with a Class-E power amplifier, a secondary circuit with a resonant circuit and a rectifier, and a pair of inductive coils by which the transcutaneous energy can be transmitted from the primary circuit to the secondary one [3]. The Class-E amplifier consists of a choke coil L_f , a switch S , a shunt capacitance C , and series resonant circuit comprised of a capacitance C_1 and a transmitter coil L_1 . The resonant circuit consists of a receiver coil L_2 and a resonant capacitance C_2 . The rectifier consists of a rectifier diode D_r and filter capacitance C_r . R_L is the load parameter.

The secondary circuit contains a diode, thus making this circuit nonlinear. To facilitate derivation of analytical parameter equation for each component, the secondary circuit is converted to a linear model by transferring the DC load to an AC equivalent linear load. The inductive coils link the primary circuit and the secondary circuit, and the impedance of the secondary circuit can be reflected into the primary one [11] as

$$\begin{aligned}
 Z_{el} &= \frac{\omega_0^2 M^2}{Z_2} \\
 &= \frac{\omega_0^2 k_0^2 L_1 L_2 (4 + \omega_0^2 C_2^2 R_L^2)}{4R_L^2 + [\omega_0 L_2 (4 + \omega_0^2 C_2^2 R_L^2) - \omega_0 C_2 R_L^2]^2} \\
 &\quad \times \left\{ 2R_L - j[\omega_0 L_2 (4 + \omega_0^2 C_2^2 R_L^2) - \omega_0 C_2 R_L^2] \right\} \\
 &= R_{el} + jX_{el},
 \end{aligned} \tag{1}$$

where ω_0 is the operating frequency, M is the mutual inductance of the primary coil L_1 and secondary coil L_2 with

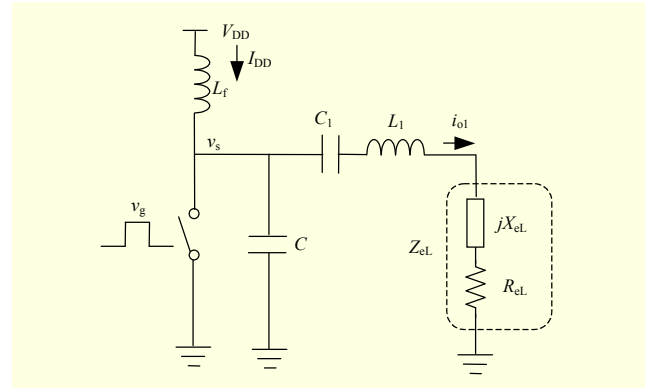

Fig. 2. Schematic diagram of the primary circuit with a reflected back resistance.

$M^2 = k^2 L_1 L_2$, k is the coupling coefficient, Z_2 is the impedance of the secondary circuit looking into the receiver from the mutual inductance, and R_{el} and X_{el} are the real and imaginary parts of Z_{el} , respectively.

With the reflected impedance Z_{el} , the primary circuit can be redrawn as a basic Class-E amplifier as shown in Fig. 2. v_g , with the duty ratio D and angular frequency ω_0 , is the driving signal for the Class-E amplifier.

III. Component Determination at Any Duty Ratio

When the TETS load R_L changes, the reflected impedance Z_{el} will change. The Class-E amplifier in the primary circuit may lose its optimum state, and the output voltage may also change. The duty ratio D and angular frequency ω_0 of the driving signal v_g require adjustment to make the TETS return to the optimum state: the supply voltage needs to be adjusted to keep the output voltage constant. In order to derive D and ω_0 as functions of R_L , the circuit component parameters are obtained as functions of D and ω_0 by frequency domain analysis of the steady-state switch voltage v_s and output current of the Class-E amplifier i_{o1} . This happens under the assumptions that the choke coil is large enough and the load quality factor is high enough.

According to the assumption of the high load quality factor, the sinusoid output current of the Class-E amplifier i_{o1} can be expressed as

$$i_{o1}(\theta) = I_{o1m} \sin \theta, \tag{2}$$

where I_{o1m} is the current amplitude and $\theta = \omega_0 t$ is the phase angle. Considering the large choke coil, the input current I_{DD} is approximate to direct current.

For the zero-voltage switching (ZVS) condition and zero-derivative switching (ZDS) condition [7], [8], [10], the output current i_{o1} equals the supply current I_{DD} at the instant when the switch turns on, as shown in Fig. 3. The relationship between

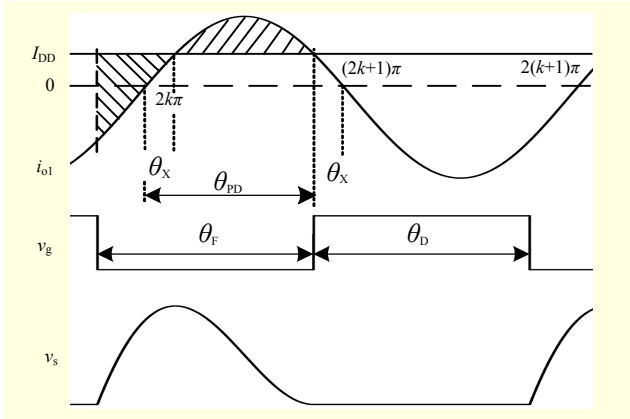

Fig. 3. Steady-state voltage and current waveforms of the ideal Class-E amplifier.

I_{DD} and i_{o1} can be expressed as

$$I_{DD} = I_{o1m} \sin \theta_X, \quad (3)$$

where $\theta_X = \pi - \theta_{PD}$, θ_{PD} is the phase angle difference between i_{o1} and v_g .

For the ZVS condition [7], [8], [10], the charge quantity of the shunt capacitance C is equal to the discharge in one switch-off duration, that is, the areas of the slash and back slash in Fig. 3, equal each other. θ_X can be determined as

$$\theta_X = \tan^{-1} \frac{1 - \cos \theta_D}{2\pi - \theta_D + \sin \theta_D}, \quad (4)$$

where $\theta_D = 2\pi D$ is the phase duration of v_g .

If the ZVS and ZDS conditions are satisfied, the average of the shunt capacitance current i_C is zero. Hence, the switch voltage v_s can be expressed in the frequency domain as

$$V_S(j\omega) = \frac{I_C(j\omega)}{j\omega C}, \quad (5)$$

where $I_C(j\omega)$ is the Fourier transform function of i_C . In the switch off duration, $i_C = I_{DD} - i_{o1}$. In the switch on duration, $i_C = 0$. i_C can be expressed in the frequency domain as

$$I_C(j\omega) = I_m \sum_{p=-\infty}^{\infty} \left\{ \begin{aligned} & \sin \theta_X \frac{2 \sin \frac{p\theta_F}{2}}{p} e^{-jp\theta_c} \\ & + \frac{2 \sin \frac{(p-1)\theta_F}{2}}{p-1} e^{-j\left[(p-1)\theta_c - \frac{\pi}{2}\right]} \\ & + \frac{2 \sin \frac{(p+1)\theta_F}{2}}{p+1} e^{-j\left[(p+1)\theta_c + \frac{\pi}{2}\right]} \end{aligned} \right\} \delta(\omega - p\omega_0). \quad (6)$$

Since the choke coil is large enough, the input current is direct, and the voltage drop of the choke coil is zero. Hence, the supply voltage V_{DD} equals the DC voltage component of V_S , writing:

$$V_{DD} = V_S(0) = \frac{I_{o1m}}{2\pi\omega_0 C} \alpha, \quad (7)$$

where $\alpha = -\theta_F \theta_c \sin \theta_X + \theta_F \cos \frac{\theta_D}{2} \cos \theta_c + 2 \sin \frac{\theta_F}{2} \cos \theta_c + 2\theta_c \sin \frac{\theta_D}{2} \sin(\theta_c)$, $\theta_F = 2\pi - \theta_D$, and $\theta_c = \frac{\theta_D}{2} - \theta_X$.

The load impedance of the Class-E amplifier at ω_0 can be expressed as $Z_{IL} = R_{eL} + j(X_{eL} + \omega_0 L_1 - 1/\omega_0 C_1)$, and it can also be determined by $Z_{IL} = V_S(\omega_0)/I_{o1}(\omega_0)$ in the frequency domain, where $V_S(\omega_0)$ is the steady-state switch voltage and $I_{o1}(\omega_0)$ is the output current. Hence, the real and imaginary parts of Z_{IL} can be obtained as

$$R_{eL} = \frac{1}{2\pi\omega_0 C} \beta \quad (8)$$

and

$$X_{eL} + \omega_0 L_1 - \frac{1}{\omega_0 C_1} = \frac{1}{2\pi\omega_0 C} \gamma, \quad (9)$$

where $\beta = [\sin \theta_X + \sin(\theta_D - \theta_X)]^2$ and $\gamma = \theta_F \cos 2\theta_X + \sin \theta_D \cos 2\theta_c$.

In the TETS, the duty ratio D , the supply voltage V_{DD} , and the output power P_{out} are always design parameters. P_{out} equals the input power P_{in} if the parasitic resistance of each component is zero. From (3), (7), and (8), R_{eL} can be expressed by P_{in} , V_{DD} , and D by

$$R_{eL} = \frac{\beta \sin \theta_X V_{DD}^2}{\alpha P_{in}}. \quad (10)$$

With the calculated R_{eL} , the shunt capacitance C can be determined by (8). The inductance L_1 can be obtained by $L_1 = QR_{eL}/\omega_0$ with the given quality factor Q . As L_1 is required to be a suitable value, it can be determined by $L_1 = 2(\pi^2/4 + 1)R_{eL}/f$ [12].

From (1), the resonant capacitance C_2 is determined under the resonant conditions ($\omega_0 = 1/\sqrt{L_2 C_2}$) as

$$C_2 = \frac{2R_{eL}}{\omega_0^2 k^2 L_1 R_L}. \quad (11)$$

Then the resonant inductance L_2 is obtained by the resonant conditions. At last, the capacitance C_1 can be determined from (9).

If the secondary circuit is adopted as a linear one, the TETS

Table 1. Design parameters of the TETS.

Parameter	Value
Output power (P_{out})	1 W
Supply voltage (V_{DD})	6 V
Quality factor (Q)	10
Duty ratio (D)	0.5
Operating frequency (f)	1 MHz
Coupling coefficient (k)	0.2
Load resistance (R_L)	1 k Ω

Table 2. Component values of the TETS.

Component	Value
L_f	400.0 μ H
C	1.4 nF
L_1	33.0 μ H
C_1	907.3 pF
L_2	31.8 μ H
C_2	795.8 pF
R_{eL}	20.8 Ω

with the design component parameter will operate in the optimum state. If the secondary circuit is adopted as a nonlinear circuit, it needs additional component parameter adjustments to make the TETS operate in the optimum state. In order to facilitate the feedback analysis, the secondary circuit is considered to be a linear one.

IV. Design Example

The component parameters are functions of the duty ratio D and the angular frequency ω_0 . Conversely, D and ω_0 have relations with component parameters as well as the load parameter R_L . In order to derive the variation trends of D and ω_0 with respect to R_L , the TETS driven by a Class-E amplifier is analyzed in a design example as follows.

1. Design Parameters

The example is designed to operate at the design parameters given in Table 1, and the calculated component values are calculated and shown in Table 2.

2. Variations of the Load Parameter

The variation of the load parameter R_L will lead to the detuning of the Class-E amplifier. It is necessary to adjust the

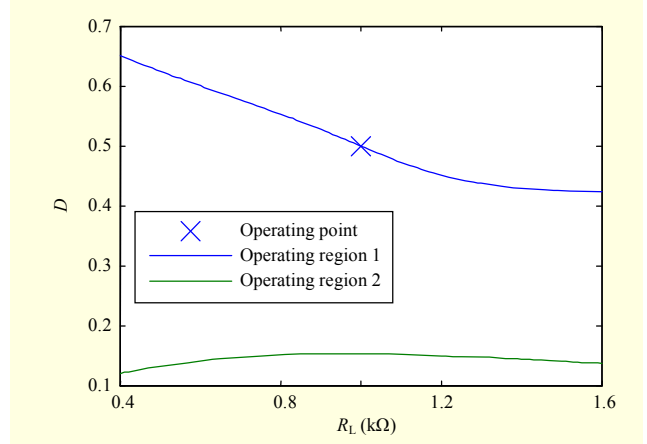

Fig. 4. D with respect to R_L .

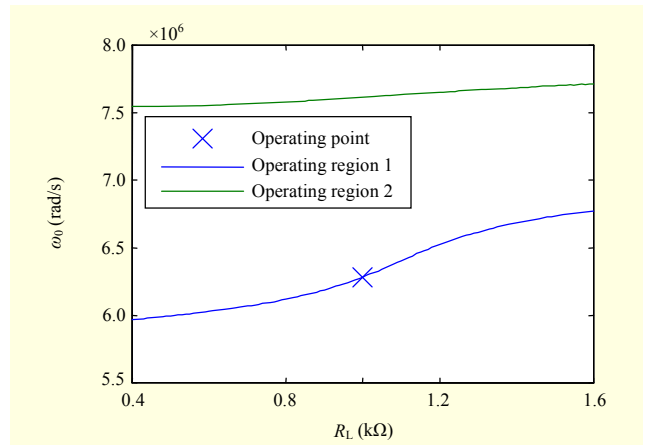

Fig. 5. ω_0 with respect to R_L .

duty ratio D and the frequency ω_0 of the driving signal v_g to keep the Class-E amplifier tuning when R_L changes.

Combining (1), (8), and (9), the relationship between D and ω_0 is determined as

$$\frac{L_2 C_2^2 R_L}{2} \omega_0^3 - \frac{L_1 C}{\alpha} \omega_0^2 + \left(\frac{2L_2}{R_L} - \frac{C_2 R_L}{2} \right) \omega_0 + \frac{C}{C_1 \alpha} + \frac{\beta}{\alpha} = 0. \quad (12)$$

It is a cubic equation at the given D and R_L . Although the equation has three roots, only one effective real root satisfies the design example. Substituting this effective root back into (1) and (8), D and ω_0 with respect to R_{eL} are obtained and shown in Figs. 4 and 5, respectively. The Class-E amplifier can be tuned in two operating regions: operating region 1 and operating region 2. The operating region 1 contains the design D and ω_0 , and the D variation range is between 0.4 and 0.7, which is a suitable duty ratio for the Class-E amplifier. However, the duty ratio of the operating region 2 is between 0.1 and 0.2, and it requires a much larger V_{DD} to reach the designated output power, thus, the operating region

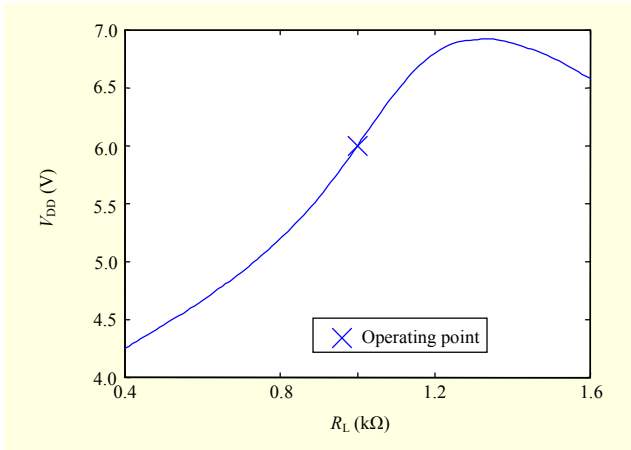

Fig. 6. V_{DD} with respect to R_L .

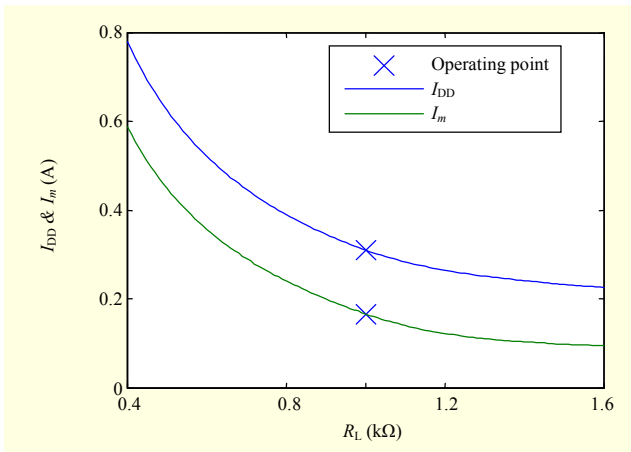

Fig. 7. I_{DD} and I_{o1m} with respect to R_L .

2 is not suitable for an actual application.

The output voltage V_o is expected to keep constant when R_L changes. The load R_L changes, and the output power P_{out} will also change. Thus, the input power P_{in} is required to be changed. Ignoring the parasitic resistance of each component, the output power P_{out} equals the input power P_{in} when the TETS operates in the optimum state. From (8) and (10), V_{DD} , as a function of R_L , is determined and shown in Fig. 6. The supply current I_{DD} and the output current amplitude of the Class-E amplifier I_{o1m} from (2) and (7) can be seen as functions of R_L (Fig. 7). I_{DD} and I_{o1m} decrease when R_{eL} increases.

3. Feedback Control

In order to implement the feedback control, the adjusted parameters need to vary with the load R_L as the designated. The phase difference θ_{PD} , which is between i_{o1} and v_g , will vary with the load parameter, and can be employed as the feedback quantity. As shown in Fig. 8, the current transformer (CT) (note that the output voltage of the CT will add 90° of phase shift)

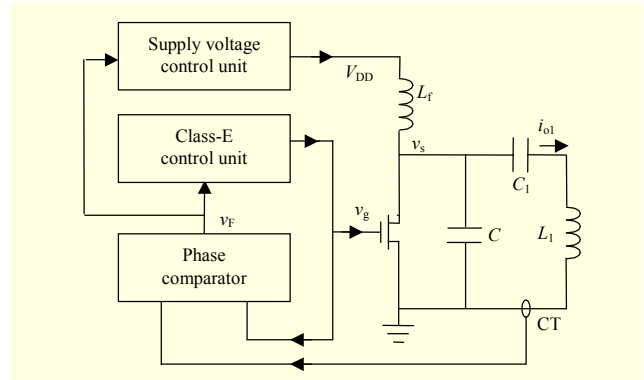

Fig. 8. Block diagram of the feedback control system.

detects the phase of the output current i_{o1} . The output of the phase comparator is the control voltage v_F , which varies with θ_{PD} in direct ratio. v_F controls the Class-E control unit to output v_g , whose duty ratio D and angular frequency ω_0 vary with R_L as shown in Figs. 4 and 5, to keep the class-E operate in the optimum state. v_F controls the supply voltage control unit to keep the output voltage constant.

4. Experiment

In order to experimentally validate the closed-loop model of the inductive power link, the design example was constructed and tested. The secondary circuit was adopted as a linear model. The MOSFET IRF 510 was employed as the switch. The driving signals were derived from a function generator. All capacitors were Silver Mica, and the inductive coils were made of the Litz wire which consists of 200 strands with the diameter of 0.1 mm. The capacitors and the inductors were measured at the intended operating frequency of 1 MHz.

The load parameter was designated to vary $\pm 50\%$ from the nominal load value. The corresponding adjustments of the duty ratio D , the angular frequency ω_0 , and the supply voltage V_{DD} are shown in Table 3. The wave forms of the switch voltage v_s and the output voltage v_o are shown in Fig. 7. Note that v_s returns to zero smoothly when the switch turns on, and the slopes of v_s are zero at the turn-on time; therefore, the Class-E amplifier operates at the optimum state. The parasitic resistance of each component are actually exists, and the efficiency is different at different load R_L [13]. V_{DD} requires additional adjustment to keep the output voltage constant. V_{DD} was adjusted to 5.1 V, 6.4 V, and 7.0 V when R_L were 500 Ω , 1000 Ω , and 1500 Ω , respectively. The input power P_{in} , the output power P_{out} , and the efficiency η are shown in Table 3. The efficiency is lower when the load is smaller because the equivalent load resistance R_{eL} is smaller, and parasitic resistance affects the power link more. In the low power

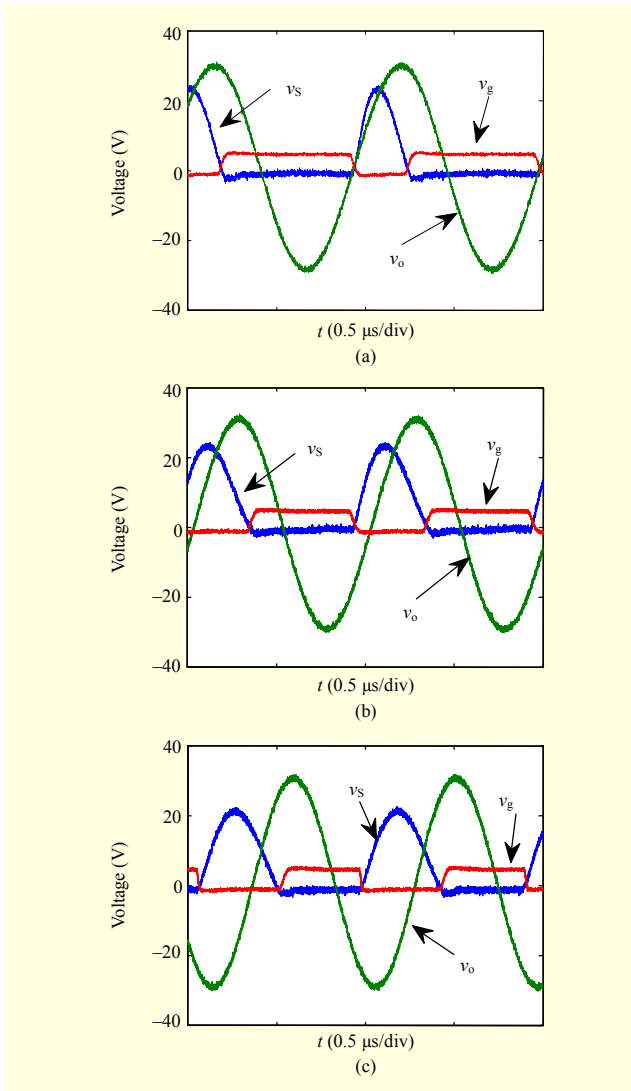

Fig. 9. Experiment waveform: (a) $R_L=0.5$ k Ω , (b) $R_L=1$ k Ω , and (c) $R_L=1.5$ k Ω .

Table 3. Adjusted parameters, power, and efficiency.

R_L (k Ω)	D	f (MHz)	V_{DD} (V)	V_o (V)	P_{in} (W)	P_{out} (W)	η (%)
0.5	0.63	0.95	4.5	31.6	2.35	2.00	85.1
1.0	0.50	1.00	6.0	31.6	1.11	1.00	90.1
1.5	0.43	1.07	6.8	31.6	0.70	0.67	95.7

implant system, such as the retinal implants, the cochlear implants, and the functional electrical stimulation applications, the reflected resistance will be large at the same D and V_{DD} . The effects of component parasitic resistance will be low, and the efficiency will be large.

V. Conclusion

The TETS with a Class-E amplifier was analyzed and the design equations were derived at any duty ratio. A design example was adopted to analyze the variation trends of the main electric parameters, such as the duty ratio and frequency of the driving signal and the supply voltage, varied with the load parameters. The duty ratio and frequency of the driving signal were adjusted to keep the TETS operating at the optimum state, and the supply voltage was adjusted to keep the output power constant. The design example with a load variation of $\pm 50\%$ was constructed to validate the theory model, and the experiment result shows that the power link operated at the optimum state with a constant output voltage.

References

- [1] P.R. Troyk and M.A.K. Schwan, "Closed-Loop Class E Transcutaneous Power and Data Link for Microimplants," *IEEE Trans. Biomed. Eng.*, vol. 39, no. 6, June 1992, pp. 589-599.
- [2] G.Z. Yan et al., "Design of Transcutaneous Energy Transmission System for Artificial Anal Sphincter," *IEEE Int. Conf. Mechatronics Automation*, 2007, pp. 1343-1438.
- [3] G.A. Kendir et al., "An Optimal Design Methodology for Inductive Power Link with Class-E amplifier," *IEEE Trans. Circuit Syst.*, vol. 52, no. 5, May 2005, pp. 857-866.
- [4] B. Lenaerts and R. Puers, "Automatic Inductance Compensation for Class E Driven Flexible Coils," *Sensor Actuat. A-phys.*, vol. 145-146, 2008, pp.154-160.
- [5] S.W. Choi and M.H. Lee, "Coil-Capacitor Circuit Design of a Transcutaneous Energy Transmission System to Deliver Stable Electric Power," *ETRI J.*, vol. 30, no. 6, Dec. 2008, pp. 844-849.
- [6] G.X. Wang et al., "Design and Analysis of an Adaptive Transcutaneous Power Telemetry for Biomedical Implants," *IEEE Trans. Circuits Syst.*, vol. 52, no. 10, Oct. 2005, pp. 2109-2117.
- [7] N.O. Sokal and A.D. Sokal, "Class E—A New Class of High-Efficiency Tuned Single-Ended Switching Power Amplifiers," *IEEE J. Solid-State Circuits*, vol. 10, no. 3, June 1975, pp. 168-176.
- [8] F.H. Raab, "Idealized Operation of the Class E Tuned Power Amplifier," *IEEE Trans. Circuits Systems*, vol. 24, no. 12, Dec. 1977, pp. 725-735
- [9] M.K. Kazimierczuk and K. Puczek, "Exact Analysis of Class E Tuned Power Amplifier at Any Q and Switch Duty Cycle," *IEEE Trans. Circuits Syst.*, vol. 34, no. 2, Feb. 1987, pp. 149-159.
- [10] T. Suetsugu and M.K. Kazimierczuk, "Off-Nominal Operation of Class-E amplifier at Any Duty Ratio," *IEEE Trans. Circuits Syst.*, vol. 54, no. 6, Jun. 2007, pp. 1389-1397.
- [11] N. de N. Donaldson and T.A. Perkins, "Analysis of Resonant

Coupled Coils in the Design of Radio Frequency Transcutaneous Links,” *Med. Biol. Eng. Comput.*, vol. 21, no. 5, 1983, pp. 612-627.

[12] M.K. Kazimierczuk and D. Czarkowski, *Resonant Power Converters*, New York: Wiley, 1995.

[13] T. Yang et al., “Power Loss and Efficiency of Transcutaneous Energy Transmission System with Class-E Power Amplifier at Any Duty Ratio,” *Int. Symp. Signals, Circuits Syst.*, 2009.

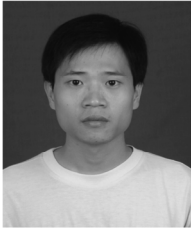

Tianliang Yang received the BS in electrical engineering and the MS in mechatronics engineering from Nanchang Hangkong University, Nanchang, China, in 2003 and 2006, respectively. Currently he is working toward the PhD in electrical engineering at Shanghai Jiao

Tong University. His research interests include power amplifier, DC/DC converters, wireless power and data transfer, implantable electronics, and smart telemetry.



Chunyu Zhao received the PhD from Shanghai Jiao Tong University, Shanghai, China, in 2000. Currently, he is an associate professor of the Department of Instrument Science and Engineering at Shanghai Jiao Tong University.

His research interests include prosthetic devices, power amplifier, dc/dc converters and inductive links, neural-electronic interfaces, and wireless biotelemetry.



Dayue Chen received his PhD from Shanghai Jiao Tong University, Shanghai, China, in 1989. Currently, Prof. Chen is the Director of the Institute of Intelligent Mechatronics Research of Shanghai, Jiao Tong University. His research interests include prosthetic devices, neural-electronic interfaces, implantable electronics,

inductive links, and smart telemetry.