

A Study on the Electrical Properties of Highly Efficient Ceramic Piezoelectric Transformer

Hyun-Seob Cho^{1*}

¹Dept. of Digital Broadcasting & Electronic Engineering, Chungwoon Univ.,

고효율 세라믹 압전 변압기의 전기적 특성에 관한 연구

조현섭^{1*}

¹청운대학교 디지털방송공학과

Abstract In this study, in order to develop multilayer piezoelectric transformer for high electromechanical coupling factor and mechanical quality factor. and to show the general approach to the design of inverters utilizing PT as a circuit element. The description of the piezoelectric effect is not present here and can be easily found in numerous publications as well as complex equations and formulae. What is the most important to understand is that "they are different" -one cannot just change an electromagnetic transformer (EMT) for a piezoelectric one. Several examples of PT-based circuitry will help to start and use multilayer piezoelectric transformer advantages most effectively.

요약 본 논문은 고효율 강압형 적층 압전변압기를 개발하기 위하여 저온소결 세라믹스 개발 및 적층 변압기를 제작하였다. 그리고 회로 요소로써 사용하는 PT는 인버터 설계의 일반적인 접근법을 보여주기 위한 것이다. 또한 압전기 영향의 기술(記述)은 다수의 연구에서 복잡한 방정식과 공식도 쉽게 찾을 수 있다. 특히 압전기 세라믹 EMT가 변화하지 않으며 PT기초 전기소자의 여러 가지 예는 더욱 효과적인 적층변압기의 적용이 가능할 것으로 판단된다.

Key Words : PMN-PZT, Multilayer Piezoelectric Transformer, High-Voltage, Piezoelectric Actuator

1. Introduction

Piezoelectric transformers can be used in the same applications as usual electromagnetic transformers but the most perspective are high output voltage low power applications and low output voltage, low and middle power (up to 50W) applications. Further on we will speak mostly about high-voltage piezoelectric transformers. In comparison with electromagnetic transformers they have some inherent features which should be kept in mind while developing schematics of inverters using HVPT. The most important for a circuit designer is the resonant frequency response of a PT. The Q factor, step-up ratio N, resonant frequency and efficiency K of a PT vary with the load resistance.

1.1 Main features of PT

Therefore there are two main problems facing a circuit designer. The first is that the inverter has to operate close to the resonant frequency of the PT even when the load resistance may change. It is necessary to obtain maximum step-up ratio and efficiency. The second is that maximum efficiency for a given PT (the dimensions of the PT are fixed) can be obtained only in a certain range of load resistance. In other words for different loads different PT should be developed.

The parameters of the model are usually given by the manufacturer or can be measured as shown in [2]. It should be kept in mind that this is the idealized model which is valid only in the vicinity of the resonant

Corresponding Author : Hyun-Seob Cho(chohs@chungwoon.ac.kr)

Received November 30, 2009

Revised January 28, 2010

Accepted April 9, 2010

frequency. In fact a PT has several resonant frequencies, so-called harmonics. For every harmonic parameters of the model are different. Usually the first (so-called $\lambda/2$ -mode, where λ is the sound wavelength in ceramic) or the second (λ -mode) harmonics are chosen, because the efficiency and step-up ratio is maximal in this case and decrease quickly with the increasing the number of a harmonic. In a practical circuit changes in drive level or load characteristics may induce "mode-hopping" that is jumping to other harmonics. So it is necessary to undertake special measures to avoid such jumping. Another important feature is the capacitive input and output impedances of PT. That means that DC current cannot flow through the input or output terminals of PT, though the equivalent circuit model shows it. The more correct model is proposed in [3] and shown at fig.1. The result is that different topology of input driver and output rectifier is used unlike EM transformer.

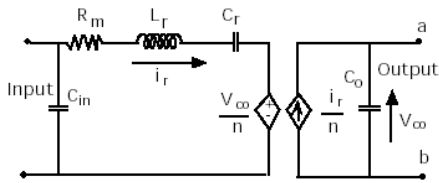

[Fig. 1] Another equivalent circuit model proposed in [3].

The input driver includes an inductor as a rule. Another reason for this inductor is to match the driver with a PT for maximum efficiency as shown in [3]. The output rectifier which is usually built as a voltage multiplier must contain even number of diodes. Finally it's important that PT has polarity. That means that if the input voltage contains DC component, like in the case of single-ended driver (fig.2), it is necessary that positive DC polarity be applied to the "+" electrode of PT. Otherwise the output voltage significantly decreases. Generally it is better to avoid applying DC voltage to PT. In the case of sine input voltage (no DC component) the polarity of PT does not matter.

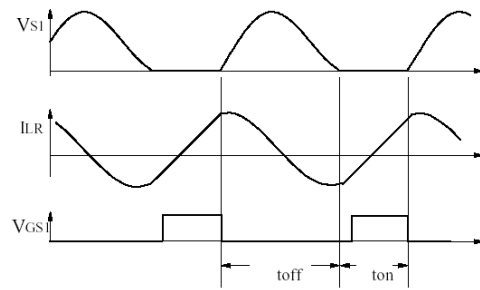

[Fig. 2] Single-ended driver wave forms (note that PT input voltage V_{s1} contains DC component).

2. Piezoelectric inverters schematic examples

All high-voltage applications of PT may be divided into two groups. The first group has relatively high load resistance – more than tens and hundreds mega ohms. It is typical for image intensifier tubes, ionizers, air cleaners, low power ozone generators, photo multipliers, laser printers and so on. The output voltage can be 1 ~ 6kV and the load current not more than 0,1 ~ 0,5mA. Another group are relatively "high-current" power supplies with output current several milli amps and output voltage 300 ~ 600V. And the typical value of load resistance is 100 ~ 300kOhm. The most popular application of PT nowadays is low profile power supplies for CCFL (cold cathode fluorescent lamp) backlight of LCD displays. Typical specifications of such kind of inverter are in the table 1 [2]. To achieve the maximum efficiency the piezoelectric transformer must be developed specially for every value of load (a lamp type). The step-up ratio is relatively small in this case (5 ~ 10) and the Q-factor is minimal.

[Table 1] Typical specifications of CCFL power supplies [2].

TAMURA PART NO.	INPUT VOLTAGE RANGE	CONTROL VOLTAGE REQUIREMENT	MINIMUM NO LOAD OUTPUT VOLTAGE	OUTPUT CURRENT	MAXIMUM OUTPUT POWER	OPERATING FREQUENCY	DIMMING	H x W x L (mm)	Weight (grams)
HBL-0217	3.0V-5.0V	5V ± 10%	800Vrms	1.5mAms	0.4W	160 KHz	PROVIDED	9.8 x 9.4 x 103.95	4.46
HBL-0210	3.0V-5.0V	5V ± 5%	800Vrms	1.0mAms	0.38W	160 KHz	PROVIDED	8.8 x 9.0 x 59.5	4.14
HBL-0204	3.0V-5.0V	5V ± 5%	800Vrms	2.0mAms	0.65W	160 KHz	PROVIDED	8.8 x 9.0 x 59.5	4.14
HBL-0214	4.5V-5.5V	N/A	1200Vrms	4.0mAms	3.00W	70 KHz	PROVIDED	5.8 x 12.5 x 142.0	11.90
HBL-0215	4.75V-5.25V	N/A	700Vrms	1.5mAms	0.60W	160 KHz	PROVIDED	4.3 x 23.0 x 46.9	3.63
HBL-0218	5.0V-10.0V	N/A	1080Vrms	2.4mAms	1.20W	160 KHz	PROVIDED	6.4 x 9.0 x 56.4	2.61
HBL-0219	8.0V-14.0V	N/A	1300Vrms	3.0mAms	2.20W	160 KHz	PROVIDED	7.4 x 13.6 x 118.0	7.97
HBL-0216	6.0V-15.0V	N/A	1250Vrms	3.7mAms	2.5W	160 KHz	PROVIDED	5.8 x 12.0 x 138.0	8.77

Speaking about the first group of applications the easiest and cheapest way is to use a self-oscillating circuit like shown at fig.3. The positive feedback is provided by capacitive antenna (it may be a bracket or a printed trace located neat the output end of a PT). The inductor L1 should be matched to obtain the maximum output voltage.

It should be noted that this simple inverter works well only when the Q-factor is high enough. In other words – when the load is 40 ~ 50 MOhm and more for the most often used PT's. Changes in load resistance (for example a breakdown in an air cleaner) may cause mode-hopping that is oscillation at the other harmonic with low output voltage. The next two-transistor inverter (fig.3) behaves a little bit better due to the higher amplification in the feedback loop. The other advantage of this circuit is that the antenna should be placed not near the end of PT but at the L/4 distance from the end, where L is the length of PT. So it is easier to provide the high-voltage isolation. In some cases the mounting bracket may serve as an antenna.

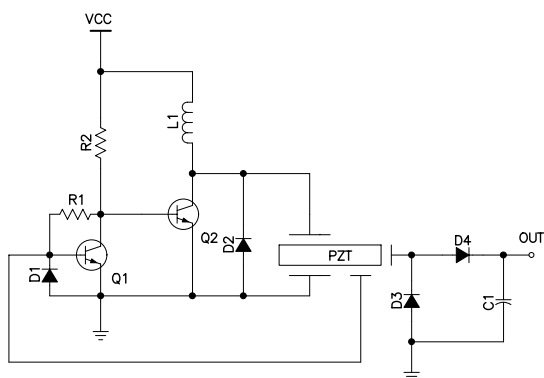

[Fig. 3] Two-transistor inverter.

For stabilizing and regulation of the output voltage or current usual voltage/current feedback circuits can be used. The regulating element may be linear as shown at fig.4 or pulsed boost converter

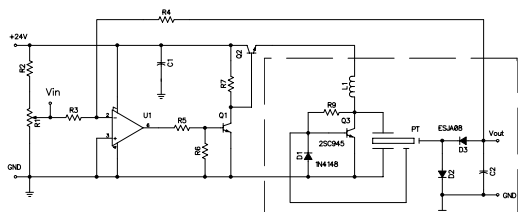

[Fig. 4] Regulated self-oscillating inverter.

To improve the load characteristic of a PT-based inverter a push-pull or totem-pole drivers can be used. In this case the input voltage of PT is almost sine which also improves the efficiency. The circuit shown at the fig.5 includes the push-pull drive stage and the pre-amplifier built on the CMOS gates (CD4069). Another feature of this inverter is the varistor Z1 which is used for the stabilizing of the output voltage. As its capacitance is high enough (about 100pF) there is no need in a capacitor connected to the Vout/2 output.

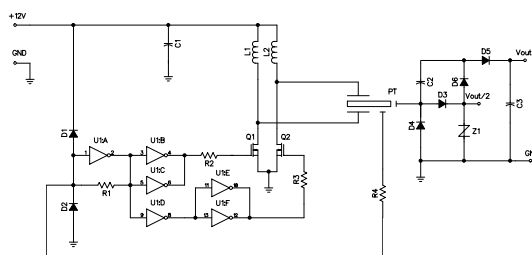

[Fig. 5] Push-pull inverter for air cleaner.

The pre-amplifier together with the high-side driver is built on the IR2109 microchip. The transformer T1 solves tree problems at once:

1. It's inductance is necessary for the matching.
2. The step-down voltage ratio helps to apply necessary input voltage to the PT (310Vp-p is too high for the PT used).
3. It enables galvanic isolation of the ozone generator from the power line.

3. Conclusion

At last the third approach is to use voltage controlled oscillator(VCO). In this case two tasks are solved simultaneously. The voltage or current feedback controls the VCO frequency so that an inverter operates as close to the resonance as it necessary to obtain the desirable value of voltage/current. Such inverters have two modes of operation. The first is the search of the resonance – initial frequency at start-up is usually higher than the resonant one and then it gradually decreases until the preset value of output parameter obtained. Since then the inverter operates in the normal mode when the feedback compensates possible changes of output voltage or current

by means of changing the operating frequency.

References

- [1] Erofeev A.A., Danov G.A., Frolov V.N.//Piezoelectric Transformers and their Applications in Radio-electronics.-Moscow, "Radio I Svyaz", 2003.
- [2] Application Note 81 Ultracompact LCD Backlight Inverters A Svelte Beast Cuts High Voltage Down to Size Jim Williams, Linear Technology Corporation Jim Phillips, Gary Vaughn, CTS Wireless Components September 2005.
- [3] Design and Analysis of Piezoelectric Transformer Converters Chih-yi Lin Dissertation submitted to the Faculty of the Virginia Polytechnic Institute and State University in partial fulfillment of the requirements for the degree of Doctor of Philosophy in Electrical Engineering. Fred C. Lee, Chair, Milan M.Jovanovic, Dan Y. Chen, Dusan Borojevic, David Gao. July 15, 2007 Blacksburg, Virginia
- [4] Analysis and Modeling of a Piezoelectric Transformer in High Output Voltage Applications Gregory Ivensky, Moshe Shvartsas, and Sam Ben-Yaakov* Power Electronics Laboratory Department of Electrical and Computer Engineering Ben-Gurion University of the Negev P. O. Box 653, Beer-Sheva 84105 ISRAEL
- [5] Performance of a High Voltage Power Supply Incorporating a Ceramic Transformer Yoshiaki Shikaze, Masatosi Imori¹, Hideyuki Fuke, Hiroshi Matsumoto¹ and Takashi Taniguchi² Department of Physics, Faculty of Science, University of Tokyo 7-3-1 Hongo, Bunkyo-ku, Tokyo 113-0033, Japan 1 International Center for Elementary Particle Physics, University of Tokyo 2 High Energy Accelerator Research Organization (KEK) 1-1 Oho, Tsukuba-shi, Ibaraki-ken 305-0801, Japan

Hyun-Seob Cho

[Life member]



- Feb. 1990 : Wonkwang University The department of Electrical Engineering
- Feb. 1992 : Wonkwang University The M.E.course of the Department of Electrical Engineering
- Feb. 1996 : Wonkwang University Graduate School The Ph.D.course of the Department of Electrical Engineering
- Mar. 1997 ~ Present : Chungwoon University Professor. Department of Electronic Engineering.

<Research Interests>

Electric and Electronics Application, Automatic Control