

Input-Series-Output-Parallel Connected DC/DC Converter for a Photovoltaic PCS with High Efficiency under a Wide Load Range

Jong-Pil Lee[†], Byung-Duk Min*, Tae-Jin Kim*, Dong-Wook Yoo*, and Ji-Yoon Yoo**

[†]* Power Conversion & System for Renewable Energy Research Center, KERI, Changwon, Korea

** School of Electrical Engineering, The University of the Korea, Seoul, Korea

Abstract

This paper proposes an input-series-output-parallel connected ZVS full bridge converter with interleaved control for photovoltaic power conditioning systems (PV PCS). The input-series connection enables a fully modular power-system architecture, where low voltage and standard power modules can be connected in any combination at the input and/or at the output, to realize any given specifications. Further, the input-series connection enables the use of low-voltage MOSFETs that are optimized for a very low $R_{DS(on)}$, thus, resulting in lower conduction losses. The system costs decrease due to the reduced current, and the volumes of the output filters due to the interleaving technique. A topology for a photovoltaic (PV) dc/dc converter that can dramatically reduce the power rating and increase the efficiency of a PV system by analyzing the PV module characteristics is proposed. The control scheme, consisting of an output voltage loop, a current loop and input voltage balancing loops, is proposed to achieve input voltage sharing and output current sharing. The total PV system is implemented for a 10-kW PV power conditioning system (PCS). This system has a dc/dc converter with a 3.6-kW power rating. It is only one-third of the total PV PCS power. A 3.6-kW prototype PV dc/dc converter is introduced to experimentally verify the proposed topology. In addition, experimental results show that the proposed topology exhibits good performance.

Key Words: DC/DC Converter, ISOP (Input-Series-Output-Parallel connected), PCS, ZVS (Zero Voltage Switching)

I. INTRODUCTION

In recent years, photovoltaic DC/DC converters have become a crucial part of power conditioning systems (PCS) [2], [3]. Considering that the output characteristic of a photovoltaic cell has a wide voltage range, depending on the operating conditions of a photovoltaic cell, the DC/DC converter needs to have a wide input voltage range to regulate the constant output voltage. In addition, a high rated voltage power switch (MOSFET) for DC/DC converters is necessary in order to be compatible with the high maximum output voltage of a photovoltaic cell. The choice of devices that can withstand such high DC voltage stress is limited and the cost is usually very high. It is thus necessary to reduce the voltage stresses of the switching device by utilizing an input series connection [8], [9]. Input series connections have many advantages such as:

- Enabling the use of MOSFETs with low voltage ratings, which are optimized for very low resistance ($R_{DS(on)}$).
- MOSFETs can be used instead of IGBTs for high input voltage applications. Hence, the switching frequency and

power density of such systems can be increased.

- Possibility of interleaving to reduce filter ratings and to improve transient performance.

This paper proposes an input-series-output-parallel connected ZVS full bridge converter with interleaved control for photovoltaic power conditioning systems (PV PCS). This paper examines the proposed topology by employing two modules and shows that it dramatically enhances the energy efficiency from low to high load conditions by reducing the required power level for the DC/DC converter by one-third of conventional DC/DC converters. This idea was first introduced in [11]. A 3.6kW prototype of a PV DC/DC converter is introduced to experimentally verify the proposed topology.

II. A NOVEL TOPOLOGY FOR PV CONVERTERS

The proposed novel topology is shown in Fig. 1 [11]. The input photovoltaic cell voltage is connected to the anode of a DC/DC converter rectifier diode. Then the DC link (inverter input) voltage is expressed as follows:

$$V_{DC} = V_C + V_{PH} \quad (1)$$

where V_{DC} is the DC link voltage, V_C is the output of the DC/DC converter and V_{PH} is the photovoltaic cell voltage.

The low power rated isolated full bridge DC/DC converter generates the difference in voltage between the PV module

Manuscript received Aug. 17, 2009; revised Oct. 23, 2009

[†] Corresponding Author: jplee@keri.re.kr

Tel: +82-55-280-1435, Fax: +82-55-280-1339, KERI

* Power Conversion & System for Renewable Energy Research Center, KERI, Korea

** School of Electrical Engineering, The University of the Korea, Korea

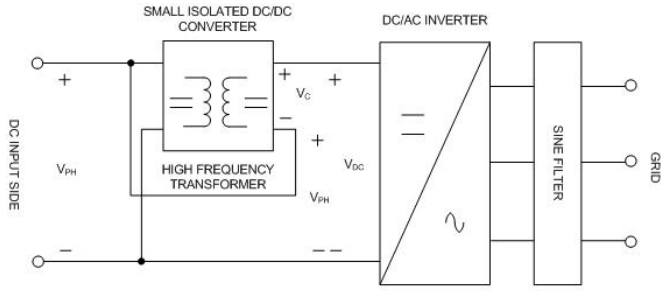

Fig. 1. The proposed PV PCS with the novel DC/DC converter.

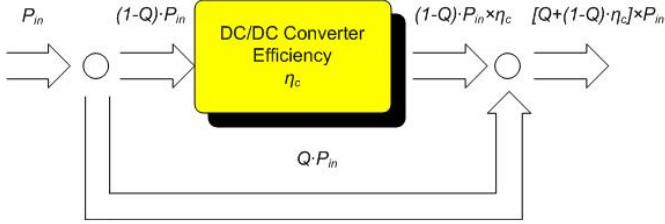

Fig. 2. The proposed converter efficiency flow diagram.

voltage and the required DC link voltage of the inverter. However, since the DC/DC converter must not generate the whole required voltage in the proposed topology, the required power capacity of the DC/DC converter is reduced dramatically.

The advantages of the proposed topology are as follows:

- High efficiency under a wide load range.
- Uses a low voltage rated power switch.
- Requires only one-third the power level of conventional DC/DC converters.

An efficiency flow diagram is shown in Fig. 2. The proposed converter's efficiency is expressed as follows:

$$\eta_{new} = Q + (1 - Q) \times \eta_c \quad (2)$$

$$Q = \frac{P_S - P_C}{P_S} \quad (3)$$

where, η_{new} is the efficiency of proposed converter, P_S is the total system power, P_C is the DC/DC converter power, η_c is the efficiency of the proposed converter and Q is the ratio of the direct power over the total power.

III. PROPOSED DC/DC TOPOLOGY FOR PV PCS

A. ISOP Topology

Fig. 3 shows the proposed DC/DC converter, which uses an isolated phase-shifted ZVS full bridge converter as the basic module. The input PV module voltage is connected to the anode of the DC/DC converter rectifier diode. Therefore, the DC/DC converter must not generate the whole required voltage in the proposed topology. It consists of a series-connected two module isolated full bridge DC/DC converter with the interleaving technique, which enables a reduction in the inductor ripple current. Fig. 4 shows the interleaved output current waveform. The phase shift between DC/DC module #1 and module #2 is 90 degree. The ripple of the output current is half of each module's current and the frequency is twice that of one module. Therefore, it can be shown to reduce filter ratings and improve transient performance.

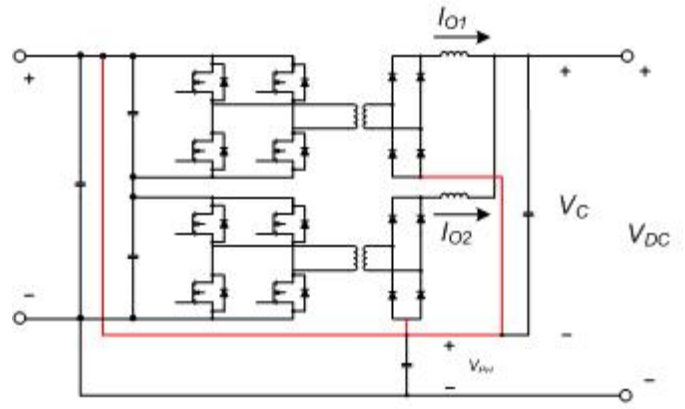

Fig. 3. The proposed ISOP full bridge DC/DC converter.

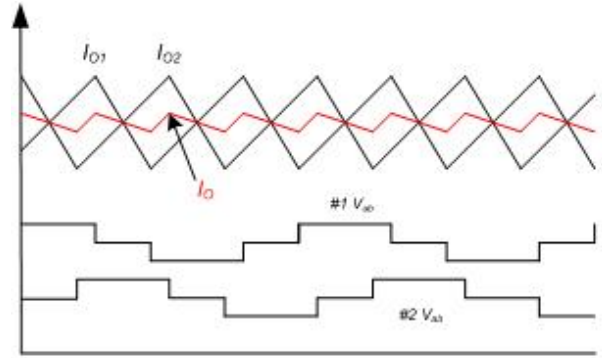

Fig. 4. The interleaved output current waveform.

B. Controller

Fig. 5 shows the proposed DC/DC converter controller which consists of a simple voltage and a current loop. The modules are controlled by interleaved switching signals, which have the same switching frequency and the same phase shift.

Where V_{M1} is the input voltage of full bridge #1, V_{M2} is input the voltage of full bridge #2, V_{PH} is the PV module

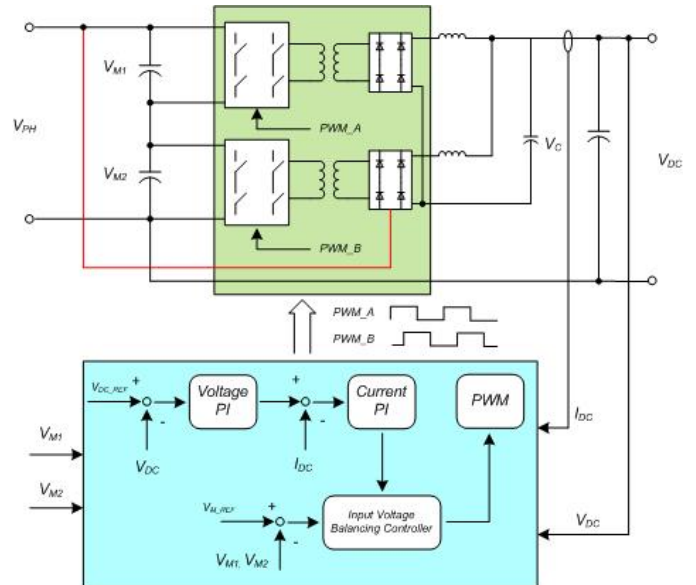

Fig. 5. Block diagram of the proposed ISOP converter controller.

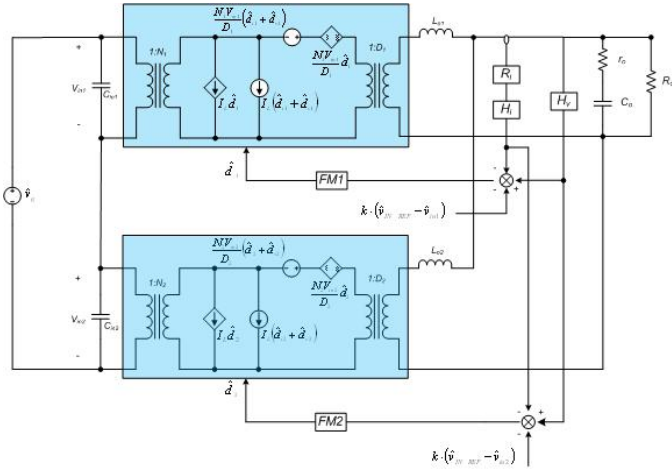

Fig. 6. The small-signal equivalent circuit of two ISOP ZVS full bridge converter.

voltage, V_{DC} is the DC link voltage (inverter input voltage), V_C is the converter output voltage ($V_C = V_{DC} - V_{PH}$), V_{DC_REF} is the reference voltage of the DC link, V_{CON_REF} is the reference voltage of the converter output and I_{DC} is the DC link current. The proposed DC/DC converter controller only keeps a DC link voltage.

The ISOP connection is well suited for applications with high input voltages and high load currents. The proposed DC/DC converter's input voltage consists of two series. As a result, it should have an input voltage balancing controller for each DC/DC module. Each individual converter, in addition to the input voltage balancing controller that adjust the PWM value, is such that the converter input voltages are equal without each having a current control loop [9]–[11].

C. Small-Signal Analysis of the Proposed Topology

The small-signal analysis presented in this paper uses the fact that the phase shift ZVS converter is a buck derived topology. A description of the circuit operation consist of the effective duty cycle d , the output filter inductor i_L , the leakage inductance L_{lk} , the input voltage $V_{in}(= V_{M1} + V_{M2})$ and the switching frequency f_s . The small signal transfer functions of this converter, therefore, will depend on L_{lk} , f_s , and the perturbations of the filter inductor current \hat{i}_L , the input voltage \hat{v}_{in} , and the duty cycle of the primary voltage \hat{d} .

Fig. 6 shows a small-signal equivalent circuit of a two module ISOP (Input Series Output Parallel) ZVS full-bridge converter system. In this figure, the overall small-signal model can be realized by adding two input voltage feedback loops to a common voltage and current control loop. The small-signal circuit model of each module is a basic phase shift ZVS full bridge PWM converter. This system has an additional input capacitor voltage control loop when compared to a conventional current mode controlled system. However, the input voltage balancing control loop has little effect on the entire system loop [10]. Therefore a small signal model of the proposed ISOP system is the same as a conventional phase shift full bridge ZVS converter.

The current loop gain T_i is determined by:

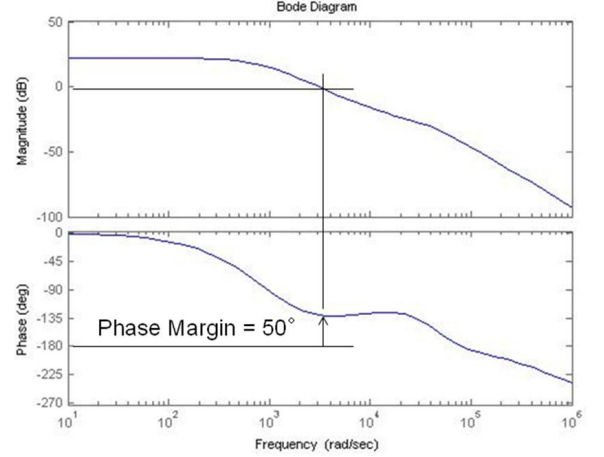

Fig. 7. The overall loop gain of proposed four ISOP converters.

$$T_i = FM \cdot R_i \cdot H_i(s) \cdot G_{di}(s) \quad (4)$$

where $G_{di}(s)$ is the control-to-output current transfer function. R_i and $FM1$, $FM2$ are the equivalent current gain and the modulator gain, respectively. $H_i(s)$ represents the sampled-and-hold effect in the current loop.

$$G_{di}(s) = \frac{1}{\Delta(s)} \frac{1}{LC} \frac{V_0}{DR} (1 + sCR)$$

$$\Delta(s) = s^2 + s \left(\frac{1}{CR} + \frac{rL + rC}{L} \right) + \frac{1}{LC} \quad (5)$$

Once the current loop is designed, the current loop closed power stage can be treated as a new power stage for the voltage loop. The system loop gain is defined as follows:

$$T_v = H_v(s) \cdot \frac{FM \cdot G_{dv}(s)}{1 + FM \cdot R_i \cdot H_i(s) \cdot G_{di}(s)} \quad (6)$$

For $H_v(s)$, an integrator plus one pole and one zero compensator are defined as follows:

$$H_v(s) = \frac{K_v(1 + s/\omega_{Zv})}{s(1 + s/\omega_{Pv})} \quad (7)$$

Fig. 7 shows the designed overall loop gain T_v which has a wide control bandwidth with a suitable phase margin (50°).

IV. MEASUREMENT RESULTS

Table 1 shows the specifications for the proposed DC/DC converter. The basic topology is the zero voltage switching (ZVS) method. The switching device is a CoolMOS MOSFET. The input voltage is PV cell voltage, the output voltage means the output voltage of an isolated DC/DC converter and the DC link voltage means a summation of the PV cell voltage and the converter output voltage.

Fig. 8 shows the proposed 3.6kW PV DC/DC converter. The photovoltaic cell voltage range is 400~800V. The DC link voltage is 630V. Fig. 9 shows the experimental results of the interleaving operation between the upper and lower module.

TABLE I
THE SPECIFICATION OF THE PROPOSED CONVERTER.

Classification	Descriptions
Input PV Cell voltage	400~800V
Converter output voltage	0~230V
DC link voltage	630V
Switching frequency	33.333kHz
Rated power	3.6kW

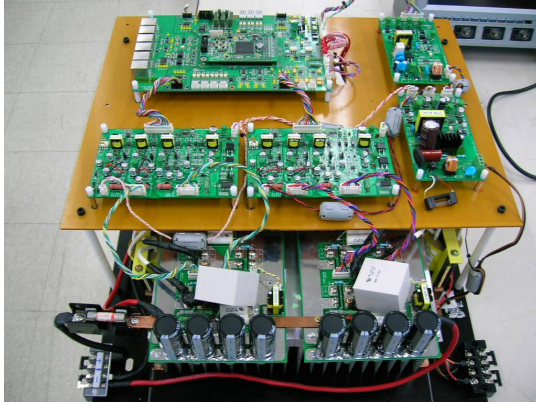

Fig. 8. The 3.6kW prototype PV DC/DC converter.

Fig. 10 shows the waveforms of the primary transformer current, the voltage, the photovoltaic module voltage and the DC link voltage. When the PV cell voltage is 450V the DC link voltage is 630V.

Fig. 11 shows the efficiency curve between a conventional converter and the proposed converter with respect to the load condition and cell voltage. It dramatically enhances the energy efficiency from the low to high voltage conditions.

V. CONCLUSIONS

In this paper, a ISOP connection topology is proposed for photovoltaic DC/DC converters with very high efficiency. The advantages of the proposed topology are as follows:

- High efficiency (Flat efficiency curve) under wide PV cell voltage and load ranges.
- Uses a low voltage rated power switch (series-connected).
- Need only 30% of the power level of conventional DC/DC converters.

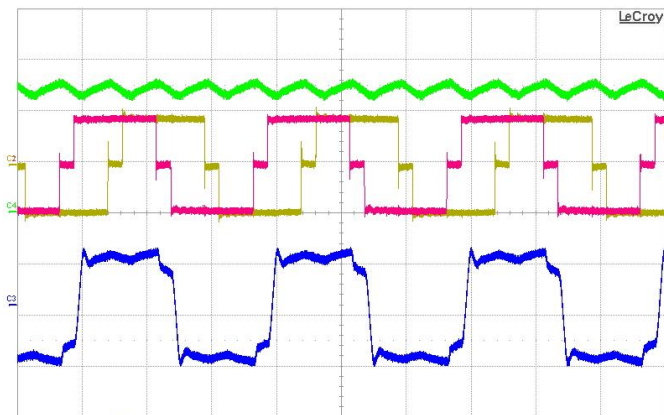

Fig. 9. Upper and lower module primary transformer voltage (CH1, 2 : 200V/div.), Upper module primary transformer current (CH3 : 10A/div.), Output inductor current (CH4 : 5A/div.).

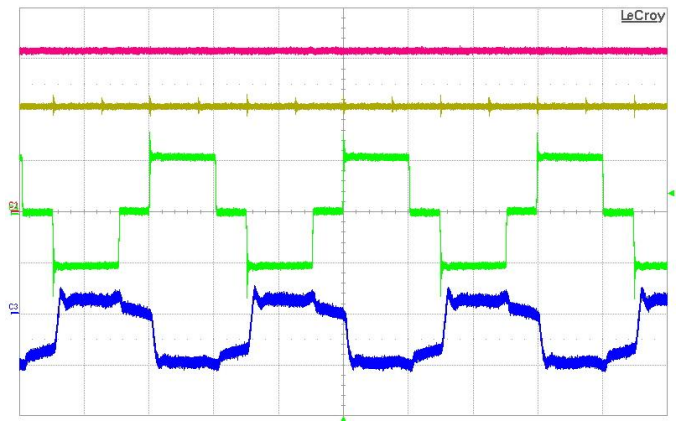

Fig. 10. PV cell voltage (CH1 : 200V/div.), DC link voltage (CH2 : 200V/div.), Primary transformer current (CH3 : 10A/div.), Transformer voltage (CH4 : 200V/div.).

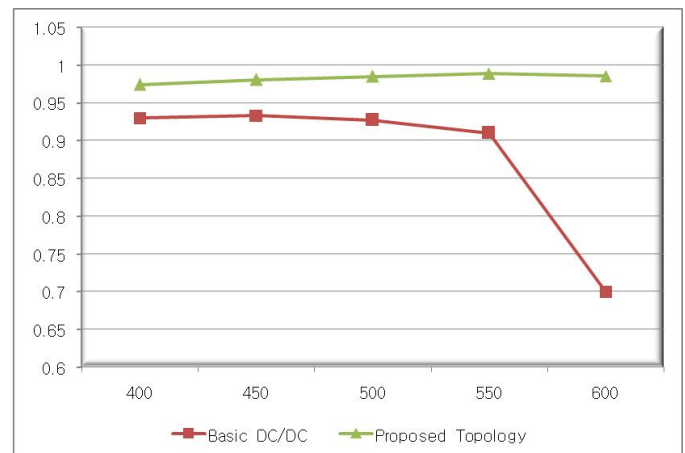

Fig. 11. Efficiency of the proposed DC/DC converter with respect to PV output voltage.

A simple controller with an input voltage control loop has been proposed for the ISOS-connected converter for photovoltaic power conversion systems. The input series connection has significant advantages such as the possibility of using MOSFETs efficiently for high input voltage applications.

Small-signal analysis shows that an equivalent phase shift ZVS full bridge converter module can be used in the control loop design process in spite of the input voltage control loop. Also a suitable 3.6kW DC/DC converter design is presented based on a full bridge ZVS converter. The performance of the proposed scheme has been verified by experimental results. It can also improve the efficiency of converters for other renewable energy applications with a high input voltage.

REFERENCES

- [1] B. D. Min, J. P. Lee, T. J. Kim, D. W. Yoo and C. Y. Won, "A New Topology for Grid-Connected Photovoltaic System Using Converter with Flat Efficiency Curve for All Load Range," *Power Electronics Specialists Conference, PESC 2007, IEEE 17-21*, pp.1250-1254, Jun. 2007.
- [2] J.-M. Kwon, K.-H. Nam, B.-H. Kwon, "Photovoltaic Power Conditioning System With Line Connection," *IEEE Trans. on Industrial Electronics*, Vol. 53, No. 4, pp. 1048-1054, Aug. 2006.
- [3] Ying-Chun Chuang, Yu-Lung Ke, "High-Efficiency and Low-Stress ZVT-PWM DC-to-DC Converter for Battery Charger," *IEEE Trans. on Industrial Electronics*, Vol. 55, No. 8, pp. 3030-3037, Aug. 2008.

- [4] Yungtaek Jang, Milan M. Jovanovic, and Yu-Ming Chang, "A New ZVS-PWM Full-Bridge Converter," *IEEE Trans. Power Electronics*, Vol. 18, No. 5, pp. 1122-1129, Sep. 2003.
- [5] Amir Ostadi, Xing Gao and Gerry Moschopoulos, "Circuit Properties of Zero-Voltage-Transition PWM Converters," *Journal of Power Electronics*, Vol. 8, No. 1, pp. 35-50, Jan. 2008.
- [6] F. J. Vorster, E. E. van Dyk, A. W. R. Leitch, "Investigation on the I-V characteristics of a high concentration, photovoltaic array," *Photovoltaic Specialists Conference*, 19-24, pp. 1604 1607, May 2002.
- [7] R. Leyva, C. Alonso, I. Queinnec, A. Cid-Pastor, D. Lagrange, L. Martinez-Salamero, "MPPT of photovoltaic systems using extremum-seeking control," *IEEE Trans. Aerospace and Electronic Systems*, Vol. 42, Issue 1, pp. 249-258, Jan. 2006.
- [8] Sirukarumbur Panduranfgan Natarajan and Thangavel Saroja Anandhi, "Control of Input Series Output Parallel Connected DC-DC Converters," *Journal of Power Electronics*, Vol. 7, No. 3, pp. 265-270, Jul. 2007.
- [9] Raja Ayyanar, Ramesh Giri, and Ned Mohan, "Active Input-Voltage and Load-Current Sharing in Input-Series and Output-Parallel Connected Modular DC-DC Converters Using Dynamic Input-Voltage Reference Scheme," *IEEE Trans. Power Electronics*, Vol. 19, Nov. 2004.
- [10] Jung -Won Kim, Jung-Sik You, and B. H. Cho, "Modeling, Control, and Design of Input Series Output Parallel Connected Converter for High-Speed-Train Power System," *IEEE Trans. Industrial Electronics*, Vol. 48, No. 3, Jun. 2001.
- [11] Jong-pil Lee, Byung-duk Min, Tae-jin Kim, Dong-wook Yoo and Ji-yoon Yoo, "A Novel Topology for Photovoltaic DC/DC Full-Bridge Converter with Flat Efficiency under Wide PV Module Voltage and Load Range," *IEEE Trans. Industrial Electronics*, Vol. 55, No. 7, pp. 2655-2663, Jul. 2008.
- [12] Jong-pil lee, Byung-duk min, Tae-jin kim, Dong-wook yoo and Ji-yoon yoo, "Design and Control of A Novel Topology for Photovoltaic DC/DC Converter with High Efficiency under Wide PV Module Voltage and Load Ranges," *Journal of Power Electronics*, Vol. 9, No. 2, pp. 300-307, Mar. 2009.

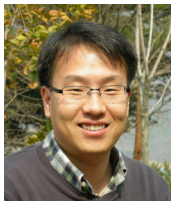

Jong-Pil Lee received a B.S. and a M.S. in Control and Instrumentation of Engineering and Electrical Engineering from Korea University, Korea in 1997 and 1999, respectively. Currently, he is working towards his Ph.D. at the School of Electrical Engineering, Korea University. From 1999 to 2005, he was a senior researcher in the Electric and Hybrid Vehicle Research department of Hyundai Heavy Industries. He has been working as a senior researcher in the Power Conversion and System for Renewable Energy Center of the Korea Electro-technology Research Institute (KERI), Korea. His main research interests are photovoltaic

PCS, ZVS DC/DC converters and power conversion for hybrid electrical vehicles.



Byung-Duk Min received a B.S. degree in Electronic Engineering at Kyungbook National University in 1990. He received a M.S. and a Ph.D. in Electronic and Electrical Engineering at POSTECH, Korea, in 1992 and 1997, respectively. He worked for Hyundai Electronics Industries and Hyundai Heavy Industries in the Electric and Hybrid Vehicle Research department from 1997 to 2004. He has been with the Renewable Research Group at KERI since 2005. His main research interests are photovoltaic PCS, photovoltaic simulators, UPS, induction & PMSM motor drivers and hybrid electric vehicle drivers.

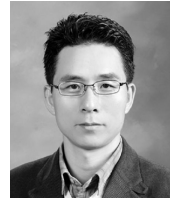

Tae-Jin Kim received a B.S., a M.S. and a Ph.D in Electrical Engineering from Pusan National University, Korea, in 1994, 1997 and 2007, respectively. From 1995 to 1996, he was a researcher at the Superconductivity Research Center, Osaka University, Japan. He has been with the Renewable Research Group at KERI since 1997, where he is currently a senior researcher.



Dong-Wook Yoo received a B.S. degree in Electrical Engineering from Sung-Kyun-Kwan University (SKKU), Suwon, Korea, in 1983, a M.S. degree in Electrical Engineering from Yonsei University, Seoul, Korea, in 1985 and a Ph.D. in Power Electronics from SKKU in 1997. He became a Researcher in 1985, a Senior Researcher in 1989 and Principal Researcher in 1997 at KERI, Changwon, Korea.



Ji-Yoon Yoo received B.S and M.S degrees in Electrical Engineering from Korea University, Seoul, Korea, in 1977 and 1983, respectively. He received his Ph.D. in Electrical Engineering from Waseda University, Tokyo, Japan, in 1987. From 1987 to 1991, he was an Assistant Professor in the Department of Electrical Engineering, Changwon National University. He joined the Department of Electrical Engineering of Korea University in 1991, where he has been active in research on the control of electric machines and drives as well as power electronics converters under major industrial and government contracts. His current research interests include modeling, analysis, and control of hybrid electric vehicle systems, BLDC motors and PM synchronous motors.