Original Paper (Invited)

Tip Clearance Losses – A Physical Based Scaling Method

Peter F. Pelz¹, Sascha Karstadt¹

¹Chair of Fluid Systems Technology, Technische Universität Darmstadt
Darmstadt, Germany

Peter.Pelz@fst.tu-darmstadt.de, Sascha.Karstadt@fst.tu-darmstadt.de

Abstract

Tip clearance losses occur in every turbomachine. To estimate the losses in efficiency it is important to understand the mechanism of this secondary flow. Tip clearance losses are mainly caused by a spiral vortex formed on the suction side of the blade of a turbomachine, which induces a drag and also has an influence on the incident flow of the blades. In this paper a physical based scaling method is developed out of an analytical ansatz for the tip clearance losses. This scaling method is validated by measurements on an axial fan with five different tip clearances.

Keywords: Tip Clearance Losses, Scaling, Vortex, Prandtl

1. Introduction

In every turbomachine several types of secondary flows appear. Most of them cause aerodynamic losses therefore it is important to understand the physical background of these mechanisms for an estimation of the influence. Between the rotating blades and the casing of a turbomachine there is a secondary flow through the tip clearance caused by the pressure gradient between the pressure and the suction side. This tip leakage flow is not involved in the work done by the rotating blades hence it reduces the aerodynamic efficiency. Additionally the flow through the tip clearance rolls up to a spiral vortex on the suction side of the blade and induces a drag. Size and circulation of this vortex, according to the Helmholtz vortex theorem, depend on the bound vortex and the size of the tip clearance. Prandtl's results of classical aerodynamic [5] applied to a turbomachine leads to a new physical motivated and analytical ansatz [1] to describe the vortex correlated losses in the pressure coefficient.

In order to estimate the losses in efficiency while changing the tip clearance a physical based scaling method can be developed. This method is validated with a fan located at the Chair of Fluid Systems Technology at the Technische Universität Darmstadt, Germany. The tip clearance of this fan can easily be varied by replacing the casing ring with a ring with another inner diameter. Measurements of the efficiency can then easily be compared with the results of the physical based scale up method.

2. Analytic Method

The performance of a turbomachine can be described with dimensionless characteristic numbers, the flow coefficient

$$\varphi := \frac{4\dot{V}}{n\pi^2 D_o^3}, \quad (1)$$

the pressure coefficient

$$\psi := \frac{2\Delta p_t}{\rho(n\pi D_o)^2}, \quad (2)$$

and the efficiency

$$\eta := \frac{\dot{V}\Delta p_t}{2Mn\pi}, \quad (3)$$

which is calculated with the volume flow rate \dot{V} , the total pressure rise Δp_t and the input power determined out of the measured torque M and the rotational speed n .

Introducing the ideal pressure coefficient

$$\psi_{ideal}(\varphi) = \frac{\psi(\varphi, Re, s)}{\eta(\varphi, Re, s)}, \quad (4)$$

which describes the ideal characteristic of a turbomachine without any losses. Where $Re = \pi n D_o^2 / \nu$ is the Reynolds number and $s = S/D_o$ the relative tip clearance based on the outer diameter of the fan.

The pressure coefficient can be split up into the ideal pressure coefficient and the pressure loss coefficient:

$$\psi = \psi_{ideal} - \psi_{loss}. \quad (5)$$

The efficiency of a turbomachine can then be determined with the quotient of the losses and the ideal pressure coefficient

$$\eta = 1 - \frac{\psi_{loss}}{\psi_{ideal}}. \quad (6)$$

The pressure loss coefficient can be divided into the tip clearance losses and the remaining losses

$$\psi_{loss} = \psi_{gap} + \psi_r. \quad (7)$$

With the physical based ansatz [1]

$$\psi_{gap} = f(s) \psi_{ideal}^2, \quad (8)$$

with $f(0) = 0$ and $f(\infty) = C_\infty$ and assuming only small relative tip clearances $s \ll 1$ a Taylor series expansion leads to

$$\psi_{gap} = Cs \psi_{ideal}^2 + O(s^2) \quad \text{or} \quad (9)$$

$$\psi_{gap} \approx Cs \psi_{ideal}^2, \quad (10)$$

where C is a machine typical dimensionless constant. With this ansatz the efficiency is given by

$$\eta = 1 - Cs \psi_{ideal}(\varphi) - \frac{\psi_r(\varphi, Re)}{\psi_{ideal}(\varphi)}. \quad (11)$$

Equation (11) gives the basis for a scaling method. Assuming that for $\varphi = \text{const.}$ and $Re = \text{const.}$ the efficiencies for two different relative tip clearances s_1 and s_2 are measured:

$$\eta_1 = 1 - Cs_1 \psi_{ideal} - \frac{\psi_r}{\psi_{ideal}}, \quad (12)$$

$$\eta_2 = 1 - Cs_2 \psi_{ideal} - \frac{\psi_r}{\psi_{ideal}}. \quad (13)$$

Solving this system of equations the two unknowns C and ψ_r can be determined:

$$C = \frac{1}{\psi_{ideal}} \frac{(\eta_1 - \eta_2)}{(s_2 - s_1)}, \quad (14)$$

$$\psi_r(\varphi, Re) = \psi_{ideal} \left(1 - \eta_1 + s_1 \frac{\eta_2 - \eta_1}{s_2 - s_1} \right) \quad (15)$$

Hence the constant C and the function $\psi_r(\varphi, Re)$ are known. If the ansatz (eq. (8)) is correct C should be a true constant, i.e. independent of φ and Re . Consequently the efficiency of a prototype can be calculated with eq. (11).

3. Experimental Setup

The experiments were performed in a fan test rig according to ISO 5136 [2] located at the laboratory of the Chair of Fluid Systems Technology at Technische Universität Darmstadt [3]. This standard defines the required setup to measure and compare the emitted acoustic power of fans and other turbo-machines. In this test case a fan with nine skewed blades, 13 guide vanes, an outer diameter of $D_o = 0.63$ m and a hub-tip ratio of $\nu = 0.45$ was mounted on the test rig. The blades have a backward sweep in the hub and a forward sweep in the tip region. They were designed using a free vortex design method with constant total pressure rise across the span of the fan blade. As shown in

Fig. 1, the fan assembly is partitioned into rings with different inner diameters which can easily be replaced to vary the tip clearance. The inner diameter of the flow path segments upstream and downstream of the rotor is designed in a way that even with the ring used for the largest tip clearance there is always a reduction in the cross sectional area. This always leads to an accelerated flow, where rounded edges at the occurring steps additionally ensure, that there is no flow separation.

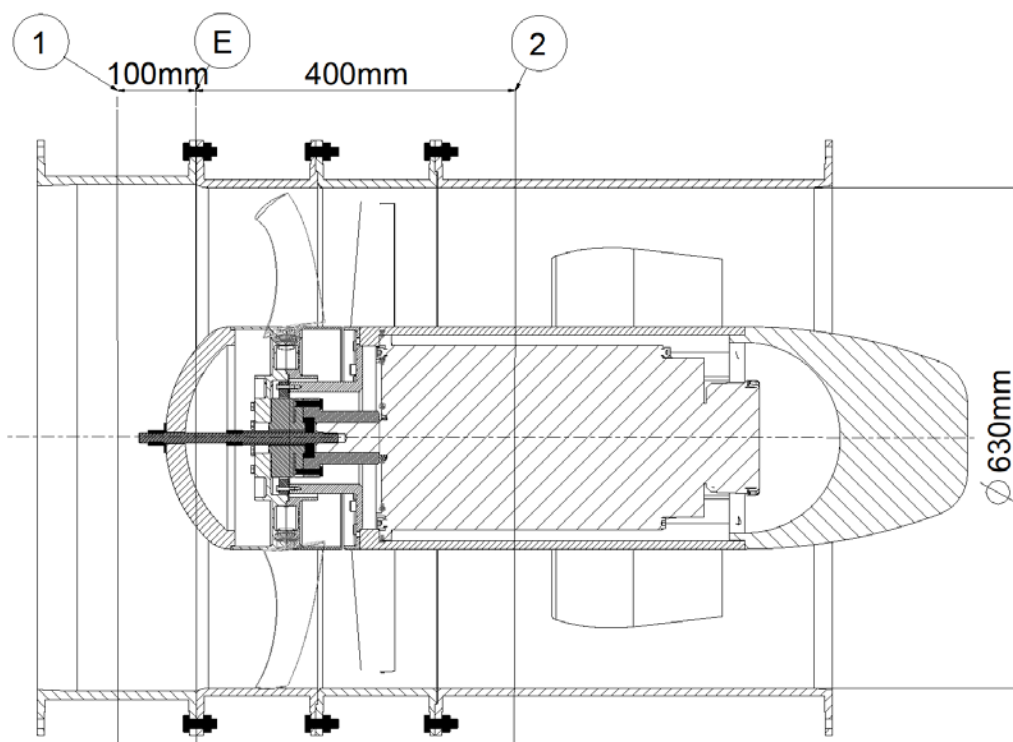

Fig. 1 Fan assembly

In [4] the tip clearances were $s = 0.1\%$, 0.2% , 0.3% , 0.5% and 0.8% of the outer fan diameter. The variation of the stagger angle ($\Delta\beta_s = 0^\circ, 6^\circ, 12^\circ, -6^\circ, -12^\circ, -18^\circ$) was realized with six sets of blades. Each set was trimmed separately in its mounted position in order to get a constant gap over the cord length. During the experiments the rotational speed was $n = 41.66$ 1/s to achieve a constant Reynolds number of $Re = 3.5 \cdot 10^6$ for air at standard conditions. The volume flow rate was determined with a calibrated inlet nozzle.

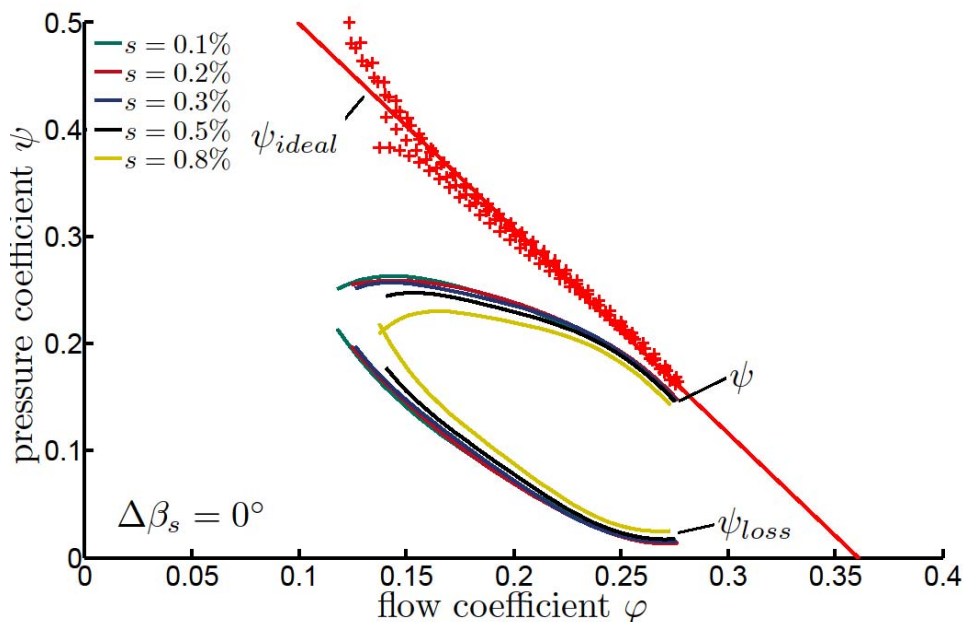

Fig. 2 Aerodynamic characteristics for $\Delta\beta_s = 0^\circ$

A throttle at the pressure side end of the test rig was used to vary the volume flow rate \dot{V} by changing counter pressure. To determine the aerodynamic efficiencies of the fan an input power has to be obtained. Therefore a flying mounted torque flange was installed between the driveshaft and the fan. Due to the direct installation at the rotor the torque M is measured without any bearing friction torque. Because of the small surface, disc friction torque is negligible compared to the aerodynamic torque. The rotational speed is kept constant with a frequency inverter directly connected to the engine. The complete experimental setup can

be found in [4]. For the validation of the developed formula the design stagger angle $\Delta\beta_s = 0^\circ$ was used.

4. Results

Fig. 2 shows the used characteristic aerodynamic numbers. For five tip clearances the pressure coefficients, the pressure loss coefficients and the ideal pressure coefficients are plotted. As it should be the ideal pressure coefficient is the same for all five tip clearances, therefore the best fit line was determined using all measured operating points. The pressure loss coefficient ψ_{loss} as shown in eq. (7) consists of all losses which occur in the fan stage.

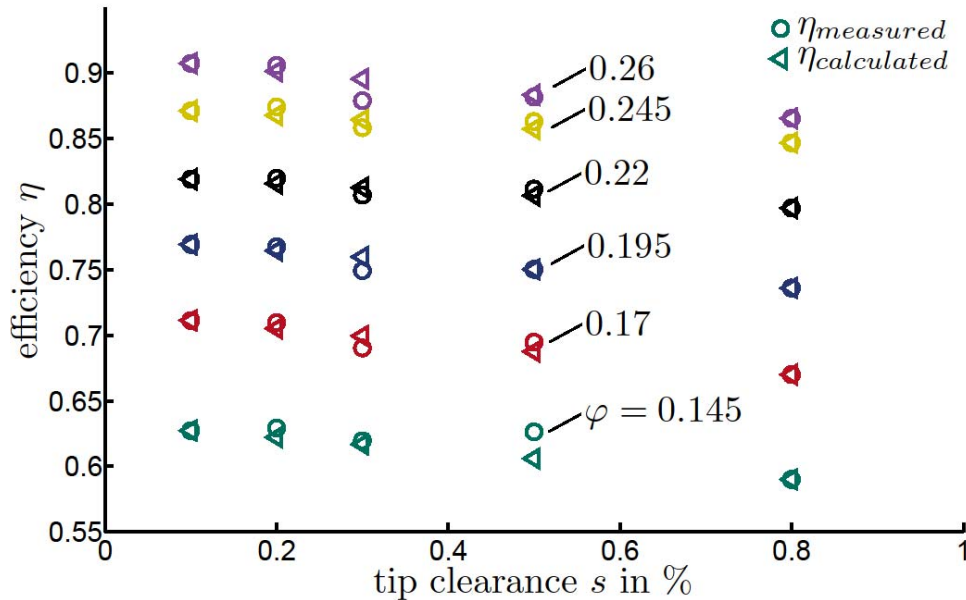

Fig. 3 Scale up for $\Delta\beta_s = 0^\circ$ at different operating points with varied C .

The tip clearance losses as part of the pressure loss coefficient can be determined with an extrapolated zero tip clearance value, which is close above the 0.1% characteristic. The figure also shows that the influence of the tip clearance grows with an increasing pressure coefficient, because of the higher pressure gradient between the pressure and the suction side of the blade the tip leakage flow and thus the tip leakage vortex grow.

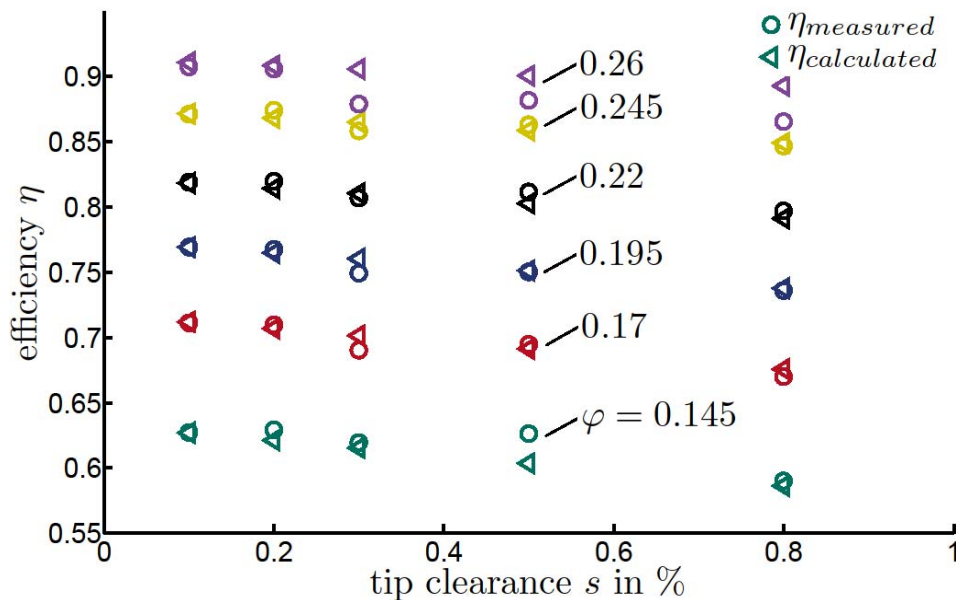

Fig. 4 Scale up for $\Delta\beta_s = 0^\circ$ at different operating points with constant C .

Due to the small pressure gradient the influence of the tip clearance is nearly negligible for large flow coefficients. The square of the ideal pressure coefficient shows the influence of the tip clearance very well as shown in Fig. 2.

For the scale up in Figure 3 six operating points ($\varphi = 0.145, 0.17, 0.195, 0.22, 0.245, 0.26$) were regarded. These operating points are equidistant distributed over the complete operating range of this axial fan. For each operating point a separate scale up was performed. The used constant C for each operating point is shown in Figure 5.

The results of the scale up formula with a variable C are shown in Figure 3. The unknown C and ψ_t are determined with the

values for the relative tip clearances $s = 0.1\%$ and $s = 0.8\%$ for each operating point. Therefore it is obvious that the measured and the calculated efficiency must fit for these points. Regarding the other tip clearances it can be seen that the calculation mostly fits very well.

To show that the machine typical constant C is independent of the flow coefficient φ , the scale up is also performed with a constant C shown as the blue line in Figure 5 for all operating points. The calculated results in Figure 4 show a very good agreement with the measured results. The values for the relative tip clearances $s = 0.1\%$ and $s = 0.8\%$ doesn't fit exact anymore, because of the average value of the machine typical constant C . With exception of the biggest flow coefficient the predicted values fit with the measured values very good. So the independence from C of φ could be proven.

In Figure 5 the calculated constant C for the regarded operating points can be seen. Except of the last point in overload region nearly an equal C for all points can be found, which fits the expectation that the tip clearance losses can be predicted with a machine typical constant. As for the first time Betz and later Prandtl [5] pointed out the induced drag coefficient of an airfoil is also a function proportional to the square of the lift coefficient and a constant geometrical parameter.

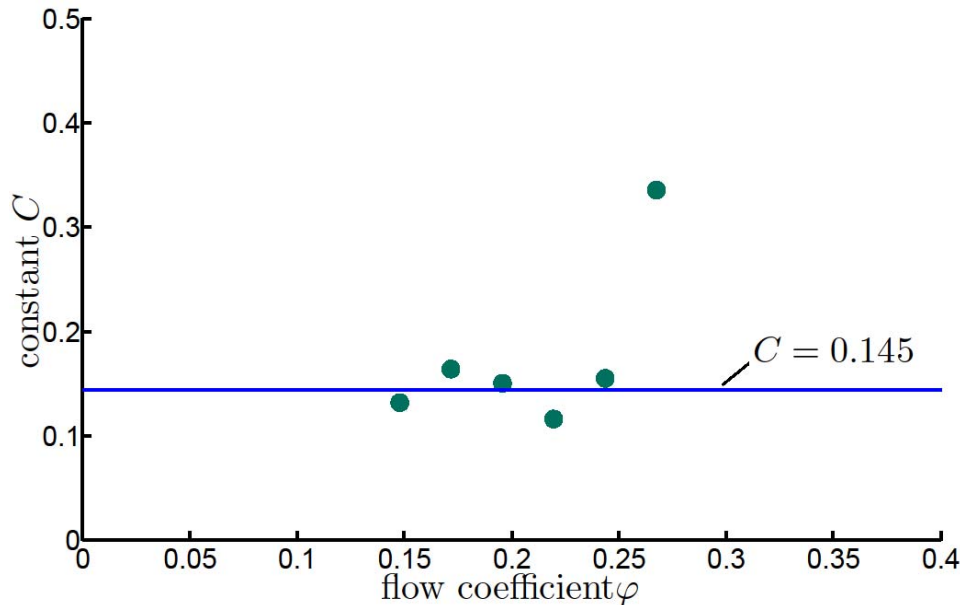

Fig. 5 C for the regarded operating points

One constant machine typical parameter lowers the effort of predicting the efficiency of a turbomachine over the whole operating range. The high value for C in the overload point is a result of the high difference of the 0.8% tip clearance curve to the remaining curves. The blue line is the average value of the operating point except of the runaway value.

The remaining losses for the regarded operating points and the related tip clearance losses can be found in Fig. 6. For clarity only the tip clearances of 0.5% and 0.8% are plotted. It is shown that for an increasing flow coefficient and therefore decreasing ideal pressure coefficient the remaining losses decrease and trend towards a limiting value. The tip clearance losses ψ_{gap} were determined with an extrapolated zero tip clearance value. The trend of the two curves shows again the quadratic dependence of the tip clearance losses which was the base of the physical based ansatz in eq. (8).

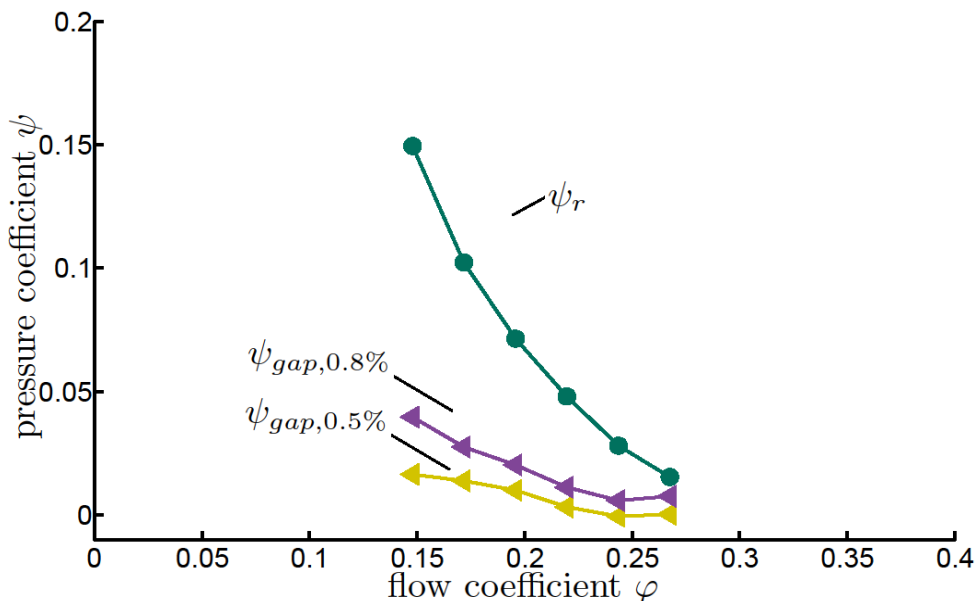

Fig. 6 Pressure loss coefficients for regarded operating points

5. Conclusion

Performance prediction is an important step when estimating the profitability of turbomachines. Due to the higher costs for the precise manufacturing of smaller tip clearance gaps it is essential to know the behavior of the aerodynamic efficiency while scaling the tip clearance. In this paper a physical based scaling method based on an analytical ansatz was presented and validated by the measurements of an axial fan with different tip clearances. The calculated results show good agreements with measurements on an axial fan with five different tip clearances.

Nomenclature

C	Dimensionless constant	η	Efficiency
D_o	Outer fan diameter in m	ν	Kinematic viscosity/hub tip ratio
M	Torque in Nm	ρ	Density in kg/m ³
Re	Reynolds number	φ	Flow coefficient
S	Tip clearance in m	ψ	Pressure coefficient
\dot{V}	Volume flow rate in m ³ /s	ψ_{ideal}	Ideal pressure coefficient
n	Rotational speed in 1/s	ψ_{loss}	Pressure loss coefficient
s	Relative tip clearance	ψ_{gap}	Tip Clearance pressure loss coefficient
Δp_t	Total pressure rise in Pa	ψ_r	Remaining pressure loss coefficient
$\Delta\beta_s$	Stagger angle in °		

References

- [1] Pelz, P. F., Heß, M.: "Scaling Friction and Inertia Losses for the Performance Prediction of Turbomachines," In: 13th International Symposium on Transport Phenomena and Dynamics of Rotating Machinery (ISROMAC-13), Paper No.: 122, 2010.
- [2] ISO 5136, 2003, "Acoustics - Determination of Sound Power Radiated into a Duct by Fans and Other Air-Moving Devices - In-Duct Method," Berlin, Beuth Verlag.
- [3] Karstadt, S., 2008, "Einfluss des Ringspalts auf die akustischen und aerodynamischen Kenndaten eines Ventilators," Diploma thesis, Technische Universität Darmstadt.
- [4] Karstadt, S. et al., 2010, "The Influence of Tip Clearance on the Acoustic and Aerodynamic Characteristics of Fans," Proceedings of ASME Turbo Expo 2010, Paper No.: GT2010-22082.
- [5] Prandtl, L., Betz, A., 1927, "Vier Abhandlungen zur Hydrodynamik und Aerodynamik," Göttingen.