

JPE 9-5-3

Series Active Power Filters to Compensate Harmonics and Reactive Power with the Direct Compensating Voltage Extraction Method in Three-Phase Four-Wire Systems

Jin-Sun Kim[†] and Young-Seok Kim^{*}^{†*}Dept. of Electrical and Electronics Eng., Inha University, Incheon, Korea

ABSTRACT

This paper presents the analysis of series active power filter for reactive power compensation, load balancing, harmonic elimination, and neutral current eradication in three-phase four-wire power systems. Generally, the three-phase four-wire system is widely employed in distributing electric energy to several office building and manufacturing plants. In such systems, the third harmonic and its 3rd harmonics are termed as triple and zero sequence components that do not cancel each other in the system neutral. Consequently, the triple harmonics add together creating a primary source of excessive neutral current. Regarding this concern, this paper presents a new control algorithm for a series hybrid active system, whereas the control approach it adopts directly influence its compensation characteristics. Hence, the advantage of this control algorithm is the direct extraction of compensation voltage reference without phase transformations and multiplying harmonic current value by gain and the required rating of the series active filter is much smaller than that of a conventional shunt active power filter. In order to show the effectiveness of the proposed control algorithm, experiments have been carried out.

Keywords: Reactive power, Series active power filters, Passive filter, Direct extraction

1. Introduction

Power quality and reliability are essential for proper operation of industrial processes that involve critical and sensitive loads. Regarding these power quality problems, such as harmonics, poor power factors, and excessive neutral line currents in 3-phase 4-wire systems are major concerns for industrial customers^[1].

In recent years, since more and more diode rectifiers with smoothing dc capacitor are used in electronic equipments, household appliances and ac drives, the harmonics generated by these loads have become a major issue. In addition, 3-phase 4-wire system is widely employed in distributing electric energy to several office buildings and manufacturing plants. These power systems show the excessive currents in the neutral line. A significant portion of this current is the third harmonic component. The third harmonic and the odd multiples of 3rd are termed as triple and are zero sequence components that do not cancel each other in the system neutral. As a

Manuscript received Oct. 29, 2008; revised July 6, 2009

[†]Corresponding Author: jsk2473@chol.com

Tel: +82-32-860-7397, Fax: +82-32-863-5822, Inha Univ.

^{*}Dept. of Electrical and Electronics Eng., Inha Univ., Korea

result, triple harmonics add together and create a primary source of excessive neutral current.

In order to defeat these drawbacks, the control algorithm for 3-phase 4-wire series active power filter, which is used to compensate the harmonics and reactive power, with the series active power filter, is proposed in this paper. Also, the value of neutral line current can be reduced by compensating the harmonics. In relation with the type of loads, the active power filter can be applied to two types of loads. One is the harmonic voltage source which consists of the parallel connection of a resistor and a capacitor in the dc-link of three-phase diode rectifier. The other is the harmonic current source which consists of the series connection of a resistor and an inductor in the dc-link of three-phase diode rectifier^[2, 3].

A harmonic detection method plays an important role in an active power filter for line harmonic suppression. The proposed control algorithm directly extracts compensation voltage references without multiplying the gain through the use of filter and the coordinate transformation. Therefore, the calculation of the compensation voltage reference will turn out to be simpler than other control algorithms. To verify the effectiveness of the proposed control algorithm, the series active power filters is manufactured and the experiments are executed with the loads consisting the harmonic voltage source and the current source in 3-phase 4wire power distribution system^[4].

To specify the difference between the proposed and the conventional method, all of piece experiments by P-Q method are also performed^[9].

2. Principle of compensation

This section introduces the control algorithm of the series active power filter that compensates harmonic currents and reactive power.

The three-phase voltages v_a, v_b, v_c and currents i_a, i_b, i_c for the three-phase three-wire power distribution system in the Fig. 1 can be expressed as the space vector \mathbf{v} and \mathbf{i} . The three-phase load voltages $\mathbf{v}_{L(a,b,c)}$ and the three-phase source currents $\mathbf{i}_{S(a,b,c)}$ are represented in equation (1).

$$\mathbf{v}_{L(a,b,c)} = \begin{bmatrix} v_{La} \\ v_{Lb} \\ v_{Lc} \end{bmatrix}, \quad \mathbf{i}_{S(a,b,c)} = \begin{bmatrix} i_{Sa} \\ i_{Sb} \\ i_{Sc} \end{bmatrix} \tag{1}$$

The active power P can be expressed by the inner product of the load voltage vector $\mathbf{v}_{L(a,b,c)}$ and the source current vector $\mathbf{i}_{S(a,b,c)}$ where the active power P is the instantaneous active power at the load side of the CT in Fig. 1, and i.e.,

$$p = \mathbf{v}_{L(a,b,c)} \cdot \mathbf{i}_{S(a,b,c)} = v_{La}i_{Sa} + v_{Lb}i_{Sb} + v_{Lc}i_{Sc} \tag{2}$$

Also, the reactive power $q_{L(a,b,c)}$ is represented as equation (3) by the cross product of $\mathbf{v}_{L(a,b,c)}$ and $\mathbf{i}_{S(a,b,c)}$.

$$\mathbf{q}_{L(a,b,c)} = \mathbf{v}_{L(a,b,c)} \times \mathbf{i}_{S(a,b,c)} = \begin{bmatrix} q_{La} \\ q_{Lb} \\ q_{Lc} \end{bmatrix} = \begin{bmatrix} v_{Lb} & v_{Lc} \\ i_{Sb} & i_{Sc} \\ v_{Lc} & v_{La} \\ i_{Sc} & i_{Sa} \\ v_{La} & v_{Lb} \\ i_{Sa} & i_{Sb} \end{bmatrix} \tag{3}$$

$$q = \|\mathbf{q}_{L(a,b,c)}\| = \|\mathbf{v}_{L(a,b,c)} \times \mathbf{i}_{S(a,b,c)}\| \tag{4}$$

where q is the instantaneous reactive power at the load side of the CT in Fig. 1^{[5], [6], [7]}.

As shown in Fig. 2, the active voltage vector $\mathbf{v}_{p(a,b,c)}$ is the projection of the load voltage vector $\mathbf{v}_{L(a,b,c)}$ in the direction of source current vector $\mathbf{i}_{S(a,b,c)}$, and the instantaneous reactive voltage vector $\mathbf{v}_{q(a,b,c)}$ is the projection of $\mathbf{v}_{L(a,b,c)}$ in the vertical direction of \mathbf{i}_s .

In this relation, the instantaneous active vectors can be obtained as follows:

The compensation voltages of series active power filter can be obtained by subtracting the instantaneous active voltages from the load voltages. Therefore, the instantaneous reactive power defined by (6) includes both

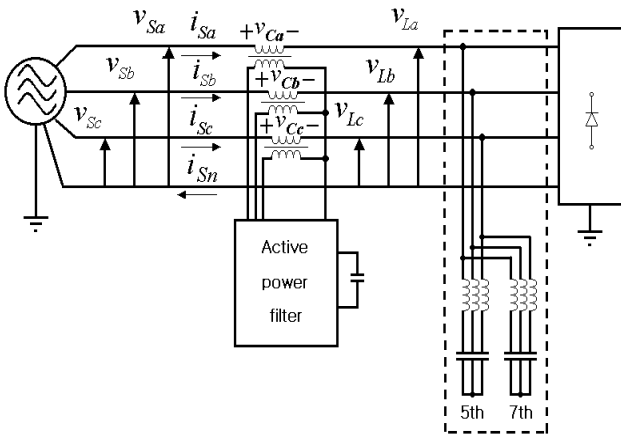

Fig. 1. Three-phase circuit.

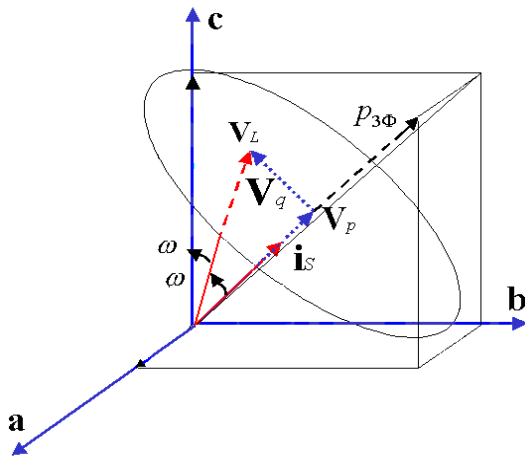

Fig. 2. Vector-diagrams of three-phase currents and voltages.

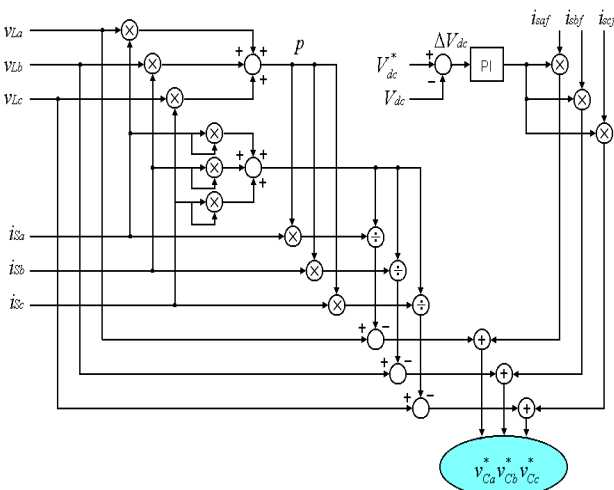

Fig. 3. Block-diagram of the control algorithm.

$$v_{p(a,b,c)} = \text{proj}_{\mathbf{v}_{L(a,b,c)}} \mathbf{i}_{S(a,b,c)} = \frac{\mathbf{v}_{L(a,b,c)} \cdot \mathbf{i}_{S(a,b,c)}}{\|\mathbf{i}_{S(a,b,c)}\|^2} \mathbf{i}_{S(a,b,c)}$$

$$= \frac{v_{La}i_{Sa} + v_{Lb}i_{Sb} + v_{Lc}i_{Sc}}{i_{Sa}^2 + i_{Sb}^2 + i_{Sc}^2} \mathbf{i}_{S(a,b,c)} = \frac{p}{i_{Sa}^2 + i_{Sb}^2 + i_{Sc}^2} \mathbf{i}_{S(a,b,c)} \quad (5)$$

$$v_{pa} = i_{Sa} \cdot p / (i_{Sa}^2 + i_{Sb}^2 + i_{Sc}^2)$$

$$v_{pb} = i_{Sb} \cdot p / (i_{Sa}^2 + i_{Sb}^2 + i_{Sc}^2)$$

$$v_{pc} = i_{Sc} \cdot p / (i_{Sa}^2 + i_{Sb}^2 + i_{Sc}^2) \quad (6)$$

the instantaneous reactive power and the instantaneous power of the zero-phase component.

If the compensation voltage is calculated by this control method, we can extract the compensating voltage of the series active power filter without transforming the phases and multiplying harmonic current value by gain. Therefore, the calculating time is short and the control method is simple compared with the conventional method^[8].

The block diagram of the entire control algorithm is shown in Fig. 3. i_{saf} , i_{sbf} and i_{scf} are the fundamental components of 3-phase source currents that are obtained by low-pass filtering. A PI controller is added to the voltage compensation references for an inverter dc-link voltage control. The inverter dc-link voltage can be controlled to follow the inverter dc-link voltage reference $V_{dc}^*_{inv}$ through PI controller.

3. System configuration

Fig. 4 shows the 3-phase 4-wire series active power filter and the combined system of the parallel passive filter with the series active power filter. In the 3-phase 4-wire series active power filter, a set of three single-phase non-linear loads as the harmonic voltage sources consist of single-phase rectifier, whereas a set of three loads as the harmonic current source consists of the series connection of a resistor and an inductor in the dc-link of single-phase bridge diode rectifier.

The input voltage of the load is 110V, 60Hz, and the value of the source inductance is 0.1mH. The converter

with RC load is used as a harmonic voltage source, while the converter with RL load is used as a harmonic current source. The value of the inverter dc-link capacitance is 2350uF. The LC filter that reduces the switching ripple of inverter switching frequency is composed of inductance $L_f=4\text{mH}$ and capacitance $C_f=0.5\mu\text{F}$. Table 1 shows the system parameters that are used to form the active power filter system. Table 2 shows the system parameter values of parallel passive filters for tuning the 5th and 7th harmonics.

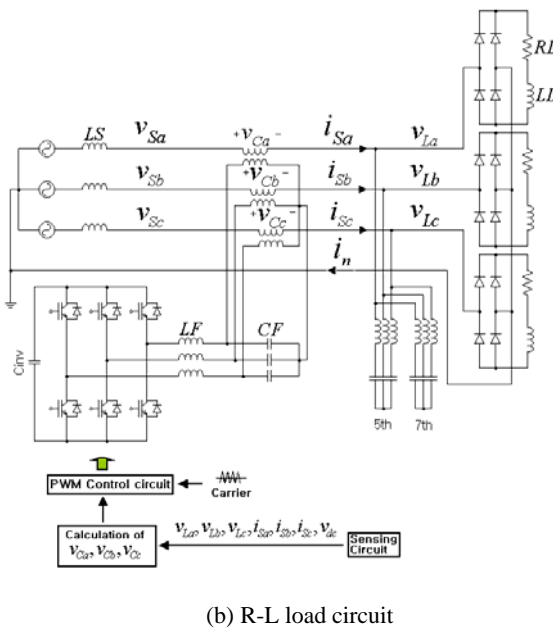
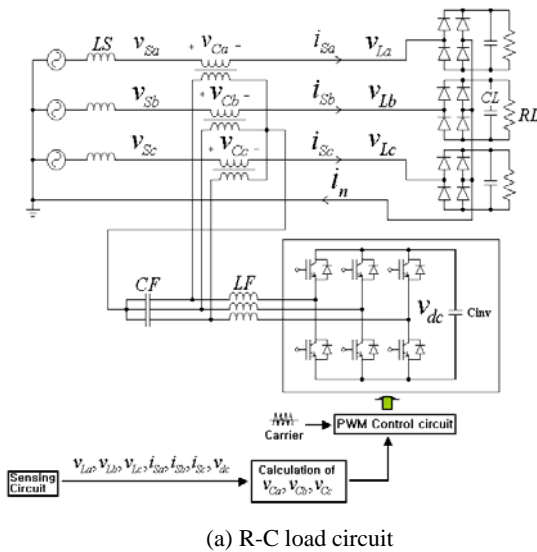

Fig. 4. Three-phase 4-wire series active power filter circuits.

Table 1. The system parameters of the series active power filter and the combined system of the passive filters and the series active power filter.

Type Parameters	3-phase 4-wire series APF	Combined system of passive and active filter
Supply voltage, Frequency	110[V], 60[Hz]	110[V], 60[Hz]
Source inductor (LS)	0.1[mH]	0.1[mH]
Transformer turn ratio	1 : 2	1 : 2
Load capacitor (CL)	2400[μF]	.
Load inductor (LL)	.	35[mH]
Load resistance (RL)	15[Ω]	15[Ω]
Inverter dc-link capacitor	2350[uF]	2350[uF]
LC-filter inductor (LF)	4[mH]	4[mH]
LC-filter capacitor (CF)	0.5[uF]	0.5[uF]

Table 2. The system parameters of the parallel passive filters.

5th passive filter	Inductor	2mH
	Capacitor	140 μF
7th passive filter	Inductor	2mH
	Capacitor	70 μF

4. Experimental results

4.1 Experimental results for the harmonic current source

The typical waveforms in the case of load that are considered as harmonic current sources are shown. Fig. 5 shows the waveforms of the load voltages, source current and its FFT (fast fourier transform) analysis of phase “a” and the neutral current. As shown in Fig. 5 (a), the source voltage and current waveforms are distorted by the current harmonic source which has severe harmonic distortion due to the 3rd, 5th, 7th and so on. Among these components, the third harmonic and the odd multiples of the 3rd are termed as a triple, and they are zero sequence components that do not cancel each other in the system neutral. Therefore, the excessive current of 2.26[A](phase, RMS) in the neutral

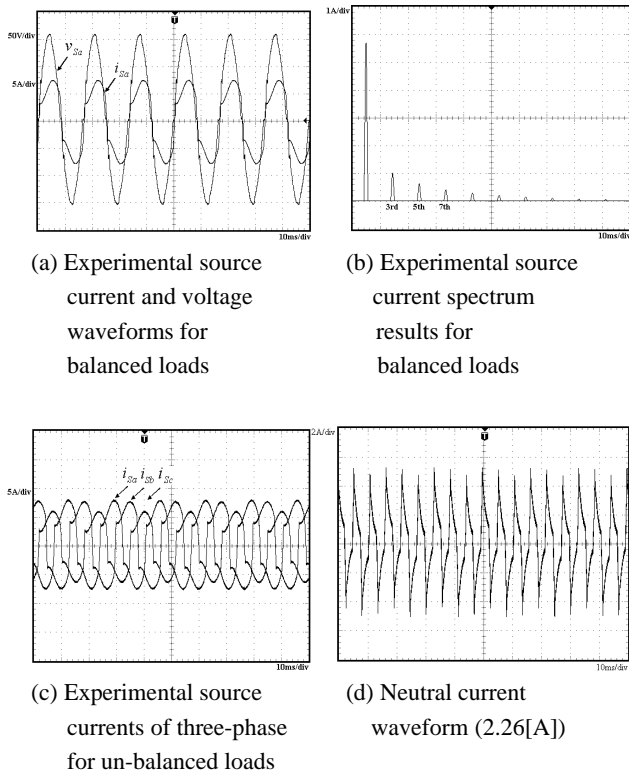

Fig. 5. Waveforms for the harmonic current source before compensation.

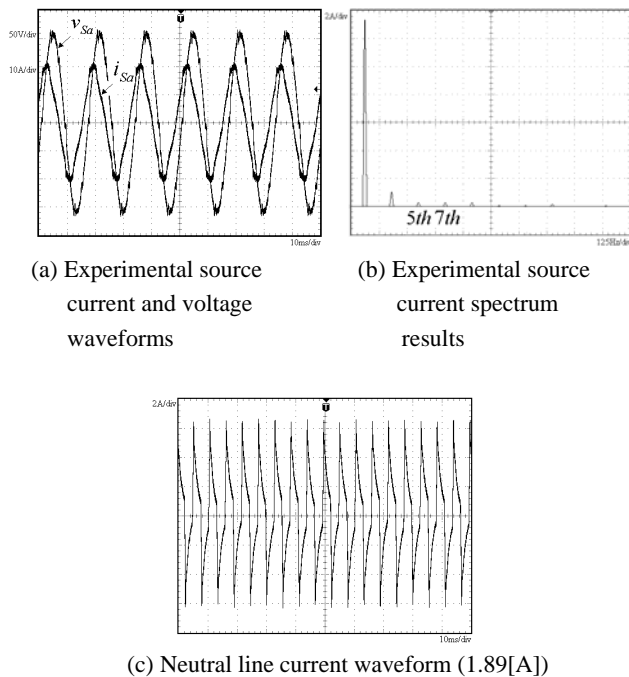

Fig. 6. Waveforms for the harmonic current source when compensated with the parallel passive filter.

line is shown in Fig. 5(c) and (d). The source current THD is 22.9% and the power factor is about 0.929 lagging.

The waveforms shown in Fig. 6 are the compensated waveforms that only use the parallel passive filters. The source current THD is 8.7% and the power factor is 0.652 leading. The amplitudes of the source currents are increased, and the power factor leads to the effective parallel passive filters. From Fig. 6(b), it is shown that 5th and 7th harmonic currents of the source currents are almost cancelled completely by the parallel passive filter. However, the source current spectrum is over 5%, as usual. Moreover, the power factor of a source stage is leading. This leading power factor and the harmonics are the reasons for degradation of power quality, and the Fig. 6(c) still exhibits the excessive zero sequence component in the neutral line.

Figure 7 shows the transient waveforms and the steady state waveforms of the phase that are compensated by the combined system of the parallel passive filter and the series active power filter, respectively. As shown in Fig. 7(a), the phase shift and harmonic compensation is performed within a half-cycle. Figure 7(b) shows that the reactive components for improving power factor are mainly compensated and it also shows that the VA rating of the active power filter can be reduced, because the passive filter compensates the 5th and 7th harmonic components, and only the other harmonics are compensated by series active filter. However, Fig. 13(d) shows that active power filter simultaneously compensates harmonics and reactive power.

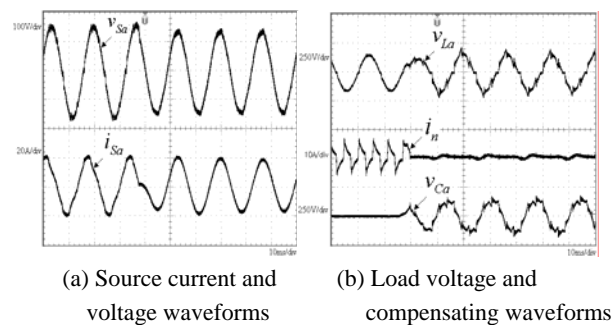

Fig. 7. Transient states experimental waveforms for the harmonic current source when compensated with the combined system of the parallel passive filter and the series active power filter.

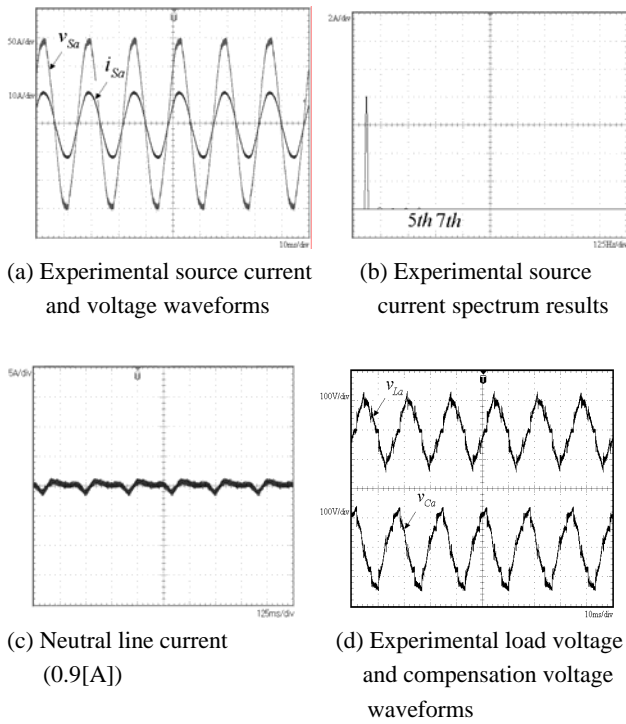

Fig. 8. Waveforms for the harmonic current source when compensated with the combined system of the parallel passive filter and the series active power filter.

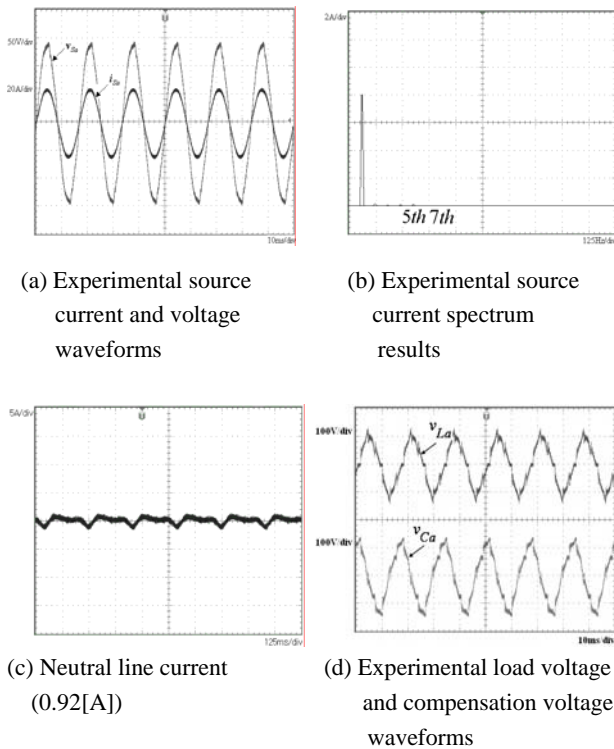

Fig. 9. Experimental results by conventional P-Q theory.

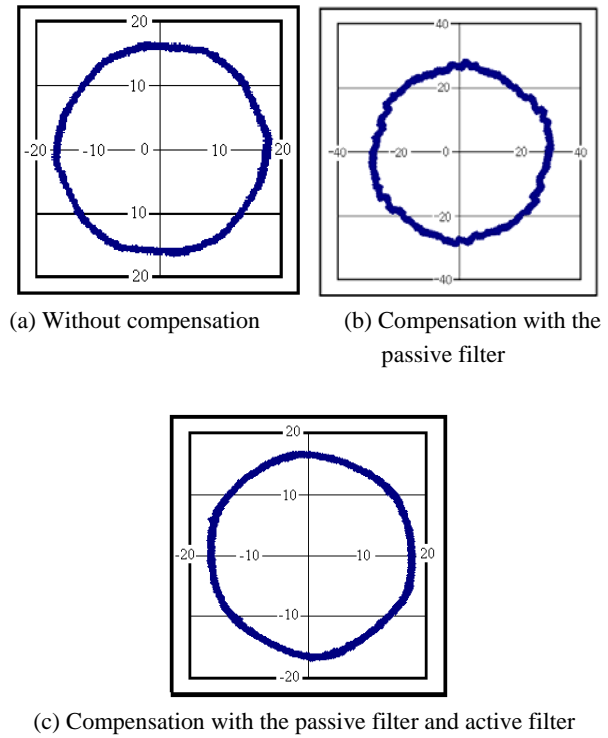
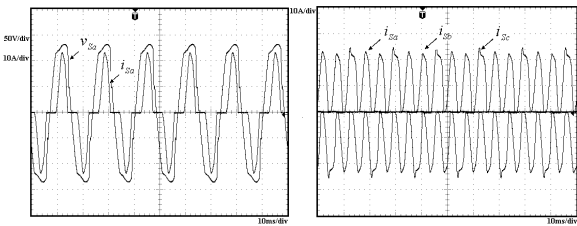

Fig. 10. Three-phase to two-phase vector transformation waveforms for source currents.

As shown in Fig. 8(a), the source current THD is 3.0%, and power factor is almost unity. The neutral current is reduced from 2.26A (phase, RMS) to 0.9A(phase, RMS) after compensation. These experimental results show that the series active power filter complements the defects of the parallel passive filter and cooperates in harmonic compensation. Moreover, the series active power factor can compensate the leading power factor as well as the source current harmonics.

Figure 9 shows the experimental results to be compensated with the conventional P-Q method. These results have similar patterns, as well, because the P-Q method also compensates harmonics and reactive power. However, the switching frequency of IGBT is reduced from 20 [Khz] to 15 [Khz].

Figure 10 shows the source current waveform which is transformed from a three-phase to a two-phase. Fig. 10-(a) is the waveform before compensation, while Fig10-(b) is the one after compensation only with the parallel passive filter applied. Finally, Fig 10-(c) is the waveform after compensation by the combined system of the parallel passive filter and the series active power filter.



(a) Experimental source current and voltage waveforms under balanced load condition
 (b) Experimental source current waveforms under un-balanced load condition

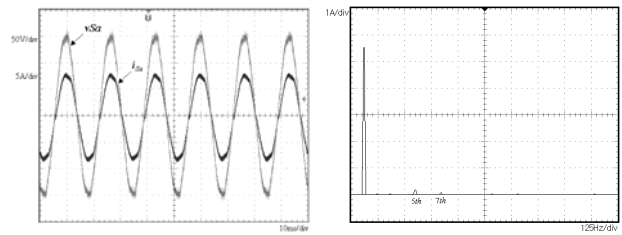

(a) Experimental source current and voltage waveforms
 (b) Experimental source current spectrum results

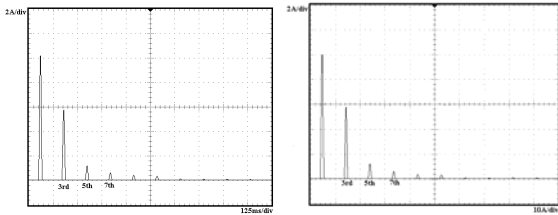

(c) Experimental source current spectrum result under balanced load condition (THD : 57.6%)
 (d) Experimental source current spectrum result under un-balanced load condition (THD : 59.2%)

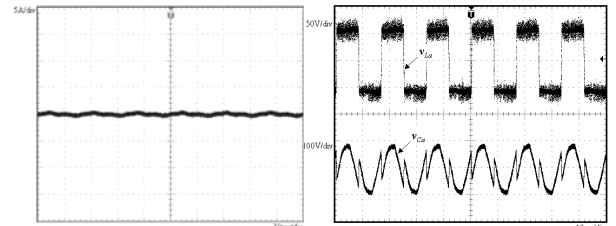

(c) Neutral line current waveform (0.5[A])
 (d) Experimental load voltage and compensation voltage

Fig. 13. Waveforms for the harmonic voltage source when compensated with the series active power filter.

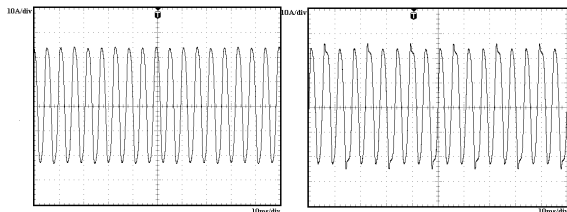

(e) Neutral line current waveform (17.9[A]) under balanced load condition
 (f) Neutral line current waveform (18 [A]) under un-balanced load condition

Fig. 11. Waveforms for the harmonic voltage source before compensation.

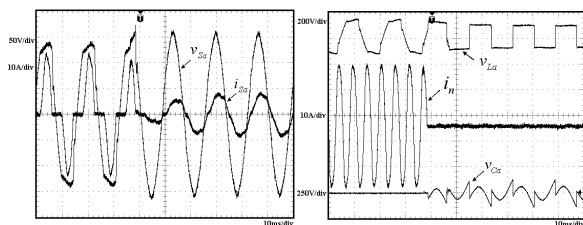

(a) Source current and voltage waveforms
 (b) Load voltage and compensating voltage waveforms

Fig. 12. Transient states experimental waveforms for the harmonic voltage source.

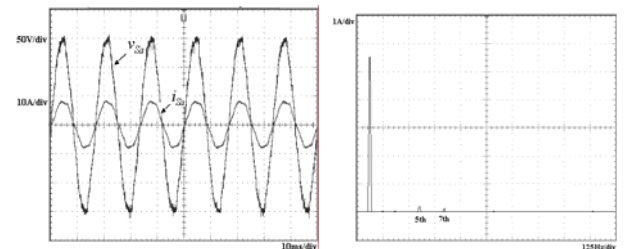

(a) Experimental source current and voltage waveforms
 (b) Experimental source current spectrum results

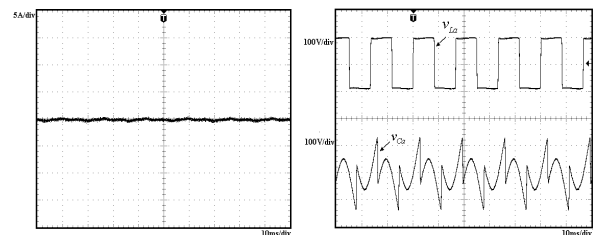

(c) Neutral line current waveform (0.5[A])
 (d) Experimental load voltage and compensation voltage waveforms

Fig. 14. Experimental results by conventional P-Q theory.

4.2 Experimental results for harmonic voltage source

Fig. 11 shows the typical waveforms in the case of harmonic voltage source. The source current THD is 57.6%, and the power factor is about 0.796. From these results, it is shown that source voltages and currents are distorted by the harmonic voltage source, as well as the harmonic current source.

Fig. 12(a) shows that harmonic compensation for the source current responded slowly within 5-6 cycles, but the voltage compensation performed rapidly. Fig. 12(b) shows that the reactive and harmonic components are compensating.

Fig. 13 shows the waveforms when they are compensated by using the series active power filter. The source current THD is 3.53% and the power factor is about 0.99. When the load is considered as a harmonic voltage source, the harmonic components of the source current and the reactive power of the load are effectively compensated, as well. The neutral current is reduced from 19.9A (phase, RMS) to 0.5A(phase, RMS) after compensation. Fig. 13-(d) shows that the reactive components for improving power factor and harmonic components are compensated.

Fig. 14 shows the experimental results to be compensated with the conventional P-Q method for voltage harmonic source. These results also have similar patterns as the harmonic current source, and the switching frequency of IGBT is reduced from 20 KHz to 15 KHz.

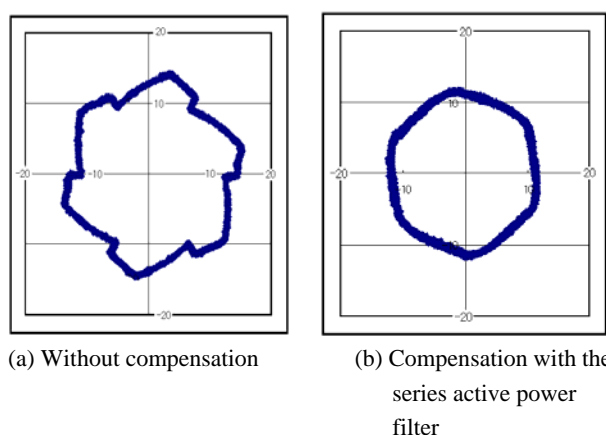

Fig. 15. Three-phase to two-phase vector transformation waveforms for source currents.

Fig. 15 shows the source current waveform from three-phase to two-phase transformation. Fig. 15-(a) is the waveform before compensation, while Fig. 13-(b) is the one after compensation the series active power filter.

From Fig. 10 and Fig.15, the harmonic compensation effect is clearly observed. According to the comparison of these three waveforms, the better the harmonics compensate, the smoother the waveforms become and the closer the circles get. In the case of harmonic current source, the harmonic components of the source current are almost zero when they are compensated by the combined system of the parallel passive filter and the series active power filter. Therefore, the waveform of Fig. 10-(c) forms almost a circle. As results of these experiments, the THD of both cases meets the IEEE std. 519. Nevertheless, it is more effective when the combined system of the parallel passive filter and the series active power filter is used. This is drawn from the fact that the parallel passive filter and the series active power filter are complementary and that they cooperate with each other.

5. Conclusions

This paper proposes a parameter measurement for PMSM including iron loss. In the proposed method, three electrical parameters of PMSM, i.e., the equivalent iron loss resistance, the armature resistance and the emf coefficient are simultaneously measured based on $P-Q$ circle diagram. This method can be applied to motor with constant field excitation machines, such as PMSM. In addition, it dispenses with the generating test for the emf coefficient. The proposed method is applied to a 160W permanent magnet synchronous motor, and the measurement results are analyzed. The equivalent iron loss resistance increases with increasing driving frequency while the armature inductance and emf coefficient are almost constant. The validity of this proposed method is confirmed by the comparison with the traditional method.

This paper shows the series active power filter system for reactive power compensation, load balancing and unbalancing, harmonic elimination and the cancellation of neutral current in three-phase four-wire power systems. In the control method, the performance of the series active power filter is improved because the delay in

compensation voltage reference calculation is shortened. This control algorithm is also applied for compensating on the harmonic current source and the harmonic voltage source. The hybrid series active filter consisted of both the 3-phase 4-wire series active power filter and the parallel passive filter, as well as the series active power filter, is manufactured. Experiments are carried out to verify the effectiveness of the proposed control algorithm, and all of piece experiments by P-Q method are also performed to specify the difference between the proposed and the conventional methods. The experiments on the harmonic current source and the harmonic voltage source are executed. The THD of source currents is lower than 5%, which meets the regulations of IEEE std. 519, and the power factors are almost unity after compensation. The neutral current harmonics are also canceled to a great extent.

These experimental results verify the effectiveness of the control algorithm and it is expected that the series active power filter contributes to resolve power quality problems, such as the harmonics, the power factor degradation and the excessive currents in the neutral.

Acknowledgment

This work was supported by New & Renewable Energy R&D program (2006NOC02P0230102008) under the Ministry of Knowledge Economy, Republic of Korea

References

- [1] Chongming, Q. et. Al., "Three-phase bipolar mode active power filters," *IEEE Trana. Ind. Appl.*, 38, (1), pp.149 – 158, Jan.-Feb. 2002.
- [2] Watanabe, E.H., et. Al., "New concepts of instantaneous active and reactive powers in electrical systems with generic loads," *IEEE Trans. Power Delivery*, 8, (2), pp. 697 – 703, April 1993.
- [3] Kim, S. et. Al., "Control Strategies for Active Power Filter in Three-phase Four-wire Systems," *IEEE Fifteenth Annual, Applied Power Electronics Conference and Exposition (APEC 2000) 1*, (6-10), pp. 420 – 426, Feb. 2000.
- [4] Moran, L., et. Al., "Series active power filter compensates current harmonics and voltage unbalance simultaneously," *IEE Proc., Gener, Transm. and Distrib.*, 147, (1), pp. 31 – 36, 2000.
- [5] Furuhashi T. et. Al., "A study on the theory of instantaneous reactive power," *IEEE Trans. on Ind. Electron.*, 37, (1), pp. 86–90, Feb. 1990.
- [6] Peng, F.Z. et. Al., "Harmonic and Reactive Power Compensation Based on the Generalized Instantaneous Reactive Power Theory for three-Phase four-Wire Systems," *IEEE Trans. Power Electron*, 13, (6), pp. 1174-1181, 1998.
- [7] Peng, F.Z. et. Al., "Generalized Instantaneous Reactive Power Theory for Three Phase Power Systems," *IEEE Trans. Instrum. and Meas.*, 45, (1), pp. 293 – 297, 1996.
- [8] Bhattacharya, S., et. Al., "Hybrid solutions for improving passive filter performance in high power applications," *IEEE Trans. Ind. Appl.*, 33, (3), pp. 732 – 747, May-June 1997.
- [9] WANG Xiaoyu, et. Al., "Frequency Characteristics of the Synchronous – Frame D-Q Method for Active Power Filters," *Journal of Power Electronics*, Vol. 8, No. 1, pp. 271-277, Oct. 2007.



Jin-Sun Kim received his B.S. and M.S. degrees in electrical engineering from the University of the Inha, Incheon, Korea, in 1986 and 1988, respectively, and a Ph.D. degree in electrical engineering from Inha University, Incheon, Korea, in 2005. He was with the Department of Electrical-Instrumental and project-engineering, LG Petrochemical CO. Ltd. and LG Engineering CO. Ltd where he is currently a electrical and project engineer in 1988~1998. His current research interests include power electronics, electrical machines, power supplies, and electrical circuits.



Young-Seok Kim received his B.S degree in Electrical Engineering from Inha University, Korea in 1977, and M.S. and Ph.D. degrees in Electrical Engineering from Nagoya University, Japan in 1984 and 1987, respectively. In 1989, he joined Inha University in Korea where he is currently a professor in the School of Electrical Engineering. His current research interests include sensorless motor drives, active power filters and power converting for renewable energy.