

Implementation of an Efficient Algorithm for a Single Phase Matrix Converter

Ajay Kumar Gola* and Vineeta Agarwal†

*Dept. of Electrical Eng., MNNIT Allahabad, India

ABSTRACT

An algorithm is developed that enables a single-phase matrix converter (SPMC) to perform functions of a generalized single phase power electronics converter such as acting as a frequency changer, rectifier, inverter, and chopper. This reduces the need for new converter hardware. The algorithm is implemented first on computer simulation software Orcad Capture CIS version 9.1. Simulation results are presented for five types of converters with a control input variable that decides the 1) type of converter and 2) type of output waveform. The simulated results verify the working and operation of a generalized converter based on SPMC. Simulated results are verified with experimental results. Hardware design is obtained using readily available ICs and other components. The trigger circuit has been tested qualitatively by observing waveforms on CRO. The operation of the proposed system has been found to be satisfactory.

Keywords: Matrix Converter, Cyclo-Converter, Cyclo-Inverter, Chopper, Inverter, Rectifier, Algorithm Development

1. Introduction

Converters come in various topologies for various functions such as frequency changer, rectifier, inverter and chopper^[1]. Fully controlled frequency changers based on cyclo converter arrangement are similar in topology to those of single phase matrix converters^[2]. Operation and maintenance of converters requires expertise to be developed and hence costly manpower. The use of a Matrix Converter in the future reduces the need for learning many varying converter topologies and that is now the subject of current active research^[3].

The Matrix Converter (MC) is an advanced circuit topology that offers many advantages such as the ability to regenerate energy back to the utility, sinusoidal input and output current and a controllable input current displacement factor^[4]. It has the potential of affording an “all silicon” solution for AC-AC conversion, removing the need for reactive energy storage components used in conventional rectifier-inverter based systems.

The topology was first proposed by Gyugyi^[5] in 1976. Previous published studies mainly dealt with three-phase circuit topologies^[6]. The Single-phase matrix converter (SPMC) was first realized by Zuckerberger^[7]. It has been shown that the SPMC could be used to operate as a direct AC-AC single-phase converter^[8], DC chopper^[9], rectifier^[10] & inverter^[11]. MC in the three-phase variant is widely researched whilst the Single-Phase Matrix Converter

Manuscript received Oct.31 2008; revised Jan. 28 2009

†Corresponding Author: vineeta@mnnit.ac.in.

Tel: +91-532-540632, Fax: +91-532-540581, MNNIT Allahabad

*Dept. of Electrical Eng., MNNIT Allahabad, India

(SPMC) has had very little attention whilst offering the possibility of a very wide application.

In this paper an algorithm is developed that enables a single-phase matrix converter (SPMC) to perform all the functions of a generalized single phase power electronics converter only by changing the input parameters. This reduces the need to design new hardware for a particular converter. The input is based on either an AC or a DC supply synthesizing both in the form of AC or DC output using well-known PWM techniques. The switching algorithm is then implemented in computer simulation models to illustrate its basic behavior. Results of the simulations are presented to verify that the proposed technique is feasible. A simple resistive load is initially used to reduce the complexities of the circuit.

2. Single Phase Matrix Converter

Fig. 1(a) shows a SPMC that requires four bi-directional switches capable of blocking voltage and conducting current in both directions. In the absence of a bidirectional switch module, the common emitter anti-parallel IGBT, with diode pair as shown in Fig. 1(b) is used. The diodes provide reverse blocking capability to the switch module. The IGBT was used due to its high switching capabilities and high current carrying capacities which are desirable for high-power applications.

The output can be synthesized by suitable toggling of the matrix switches subject to the conditions that ensures the switches do not short-circuit the voltage sources, and do not open-circuit the current sources.

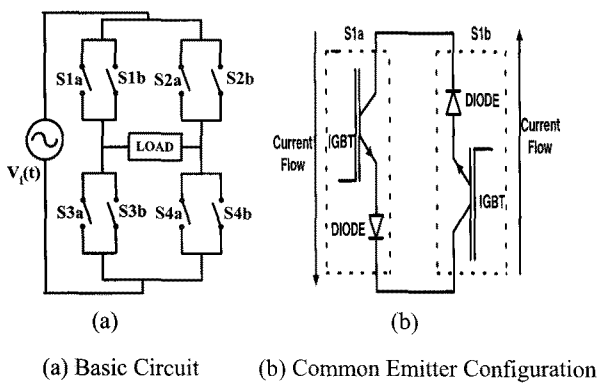

Fig. 1 Single Phase Matrix Converter

The advantage of this approach is that it can be developed for any kind of input (AC or DC) and produces any output (AC or DC). Thus, if input is DC, then for an inverter operation positive half output switches S1a and S4a will conduct while negative output switches S2a and S3a will conduct as shown in Fig. 2 (a) and (b) respectively.

Similarly if input is AC then there are four switching states that can be explained with the cyclo-converter operation. Fig. 3 shows the cyclo-converter operation for half of the input frequency. In the positive input cycle if the output is positive switches S1a and S4a will conduct while in the negative input cycle if the output is positive switches S3b and S2b will conduct. The negative half output of cyclo-converter is obtained by conduction of switches S2a and S3a and switches S4b and S1b as shown in Fig. 3 (a) and (b) respectively.

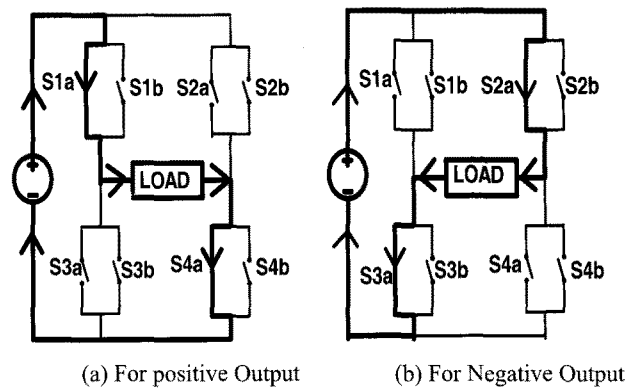
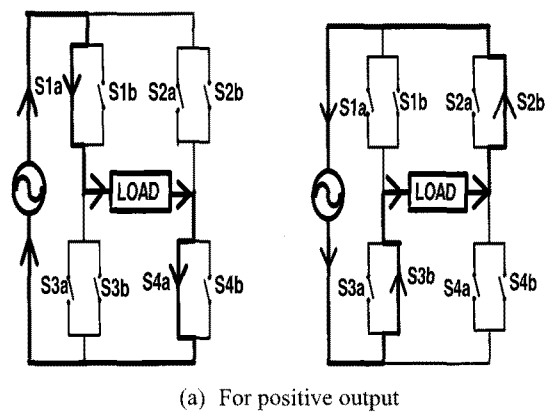
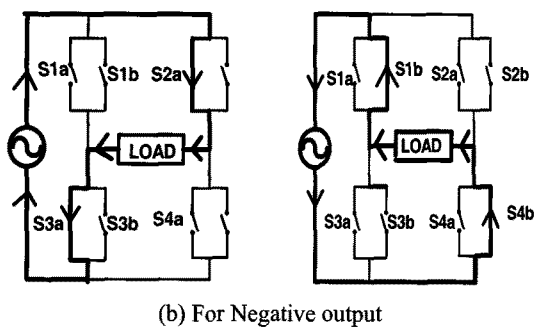

Fig. 2 Inverter operation





(b) For Negative output

Fig 3 Cyclo Converter Operation

Of the various types of modulation techniques available the PWM implementation is chosen for its simplicity. The AC output uses the Sinusoidal Pulse Width Modulation (SPWM), whilst the DC output is synthesized using the simple Multiple Pulse Width Modulation (MPWM). The standard SPWM and MPWM operation principles can be illustrated with Fig. 4 (a) and Fig. 4 (b) respectively.

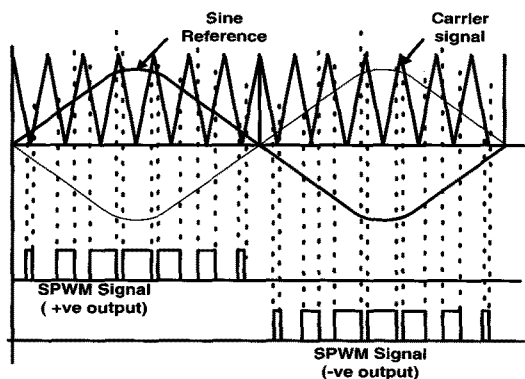

(a) SPWM

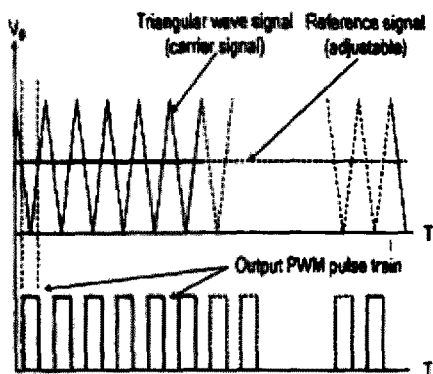

(b) MPWM

Fig. 4 Modulation Techniques

3. Proposed Algorithm

Fig. 5 shows the block diagram of the algorithm to synthesize a particular converter from a generalized single phase matrix converter.

Initially, some basic signals are required to synthesize any converter from the generalized SPMC. These signals are generated in the basic signal generator block. A particular converter is selected in a block Selection of Converter & Input Supply. Depending on the converter the required input supply may be either AC or DC. For example, for chopper and inverter operations the input supply will be DC, whereas for other converters it will be AC. Once a converter and supply is selected, the next step is to generate the trigger pulses for that converter. The trigger signals for a particular converter operation are synthesized in a logical operator block. Output of the logical operator is then fed to a generalized SPMC through an isolating and driver circuit. The details of each block are explained in the following sections

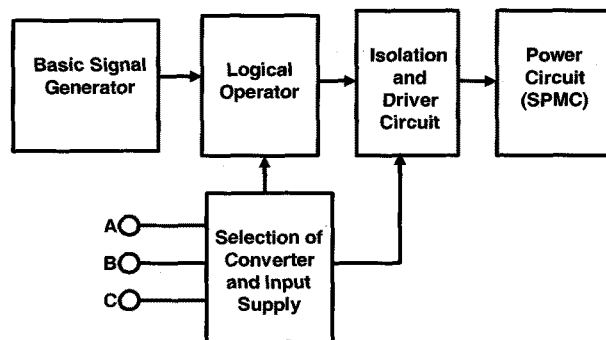

Fig. 5 Block diagram of the algorithm

3.1 Basic Signal Generator

Fig 6 shows the block diagram for the generation of basic signals and Fig. 7 shows these signals. First signal X1 which is a triangular wave is generated by the block *triangular wave generator* the frequency of which decides the harmonics content in the output wave form.

Other signals are generated by comparing this triangular wave either with a sine wave of input frequency or a sine wave having its frequency multiplied or divided by an integer N or with the DC reference voltage depending upon converter operation. Here N is any integer that

decides the output frequency of the cyclo-inverter or cyclo-converter. The signal X2 is a positive cycle of the SPWM which is generated by comparing the positive cycle of the sine wave having frequency $N \times f_i$ with a generated triangular wave. Similarly, signal X3 is generated by comparing the negative cycle of sine wave frequency $N \times f_i$ with a triangular wave.

square wave and a negative cycle square wave of 50 Hz respectively. The basic signal X10 is a PWM wave which is generated by comparing the triangular wave with the DC reference voltage. Signal X11 and X12 are a positive cycle square wave and a negative cycle square wave of frequency f_i / N , respectively.

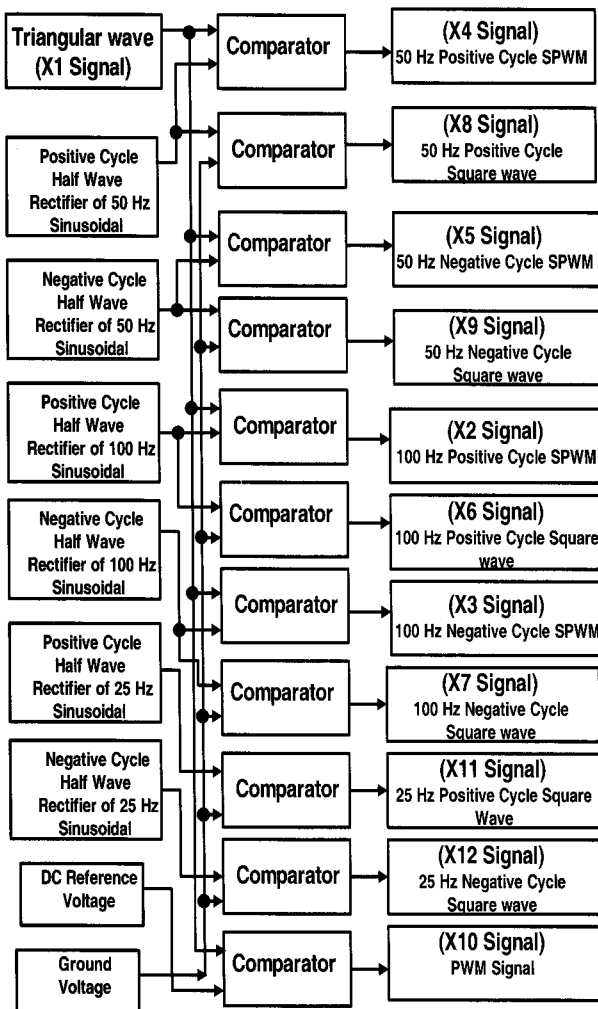

Fig. 6 Block diagram for the generation of Basic Signals

The basic signal X4 is a 50 Hz positive cycle SPWM which is generated by comparing the positive cycle of 50 Hz sine wave with the triangular wave. The signal X5 is a 50 Hz negative cycle SPWM, generated by comparing the negative cycle of 50Hz sine wave with the triangular wave. Signal X6 and X7 are a positive cycle square wave and a negative cycle square wave of frequency $N \times f_i$, respectively. Signal X8 and X9 are a positive cycle

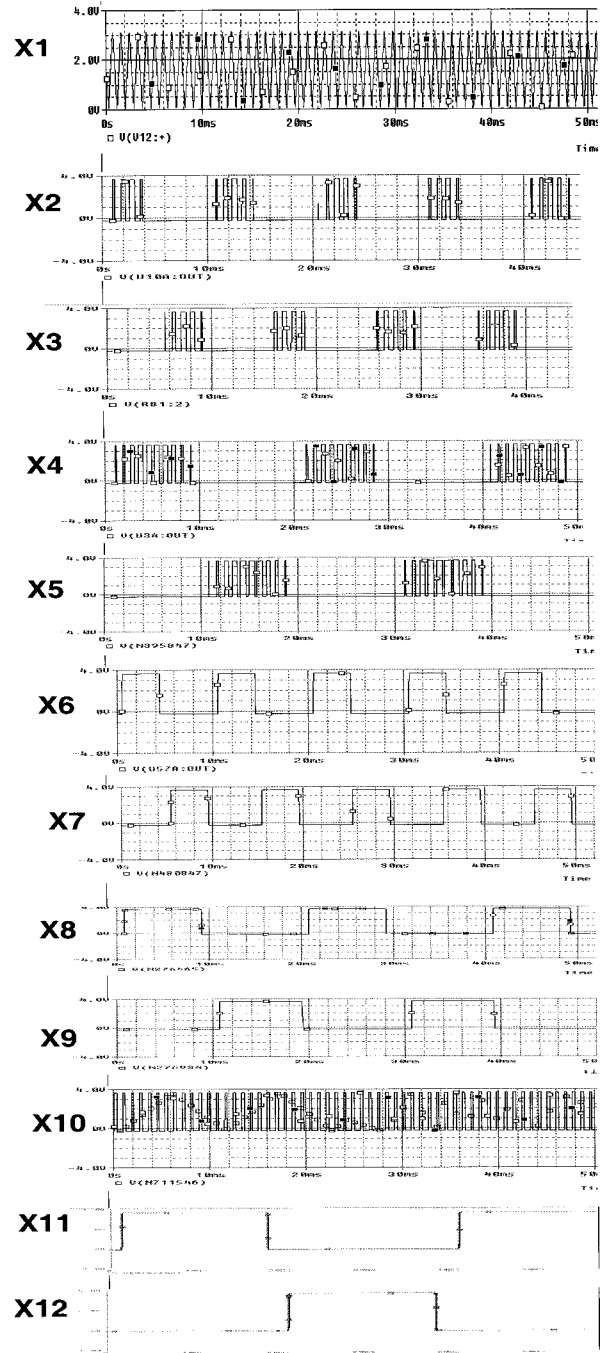

Fig. 7 Basic Signals

3.2 Selection of Converter and Supply

Selection of a particular converter is realized by a combination circuit shown in Fig 8. This combination circuit will work in accordance to a 3 × 8 decoder with 8 separate output channels (Y0, Y1, ---- up to Y7), one for each converter. A particular converter is selected by taking a 3 bit input word ABC from the user and decoding it by a 3 × 8 decoder according to the truth table shown in Table 1. For Example if A = 1, B = 1, and C = 1, the output line Y7 will high while all other lines will be low. So the converter function connected to the Y7 output line will be enabled.

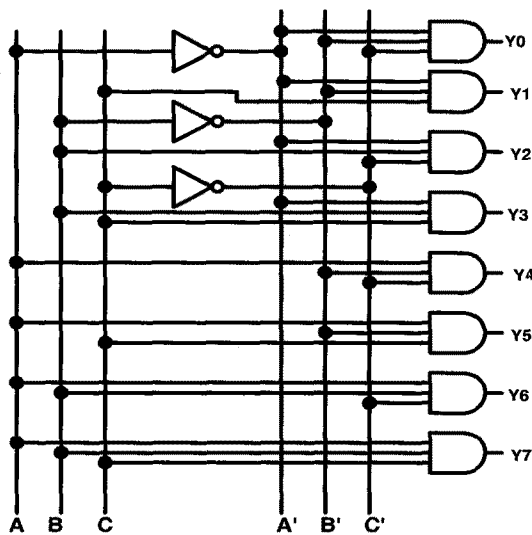

Fig. 8 Combinational Circuit

Table 1 Truth Table for Decoder

A	B	C	Selected Output
0	0	0	Y0
0	0	1	Y1
0	1	0	Y2
0	1	1	Y3
1	0	0	Y4
1	0	1	Y5
1	1	0	Y6
1	1	1	Y7

For generalized converter operation two types of supply sources. The first is a DC source and other is a single phase 50 Hz AC. Based on converter operation one supply is selected as a source. One IGBT is connected in series

with each input source. Triggering of a particular IGBT will select the input source for converter operation. From Table 2 it can be seen that for chopper and inverter operation a converter enabling signal (Y5 and Y7) is required and at the same time the input source voltage required will be DC. Hence, the selection of a DC supply is done by logical operator signal $S5b = Y5 + Y7$ Here S5a is the IGBT switch that is connected in series with the DC source.

The selection of AC supply is done by logical operator signal $S5b = \overline{Y5 + Y7}$ Here S5b is the IGBT switch which is connected in series with the AC source as shown in Fig. 9.

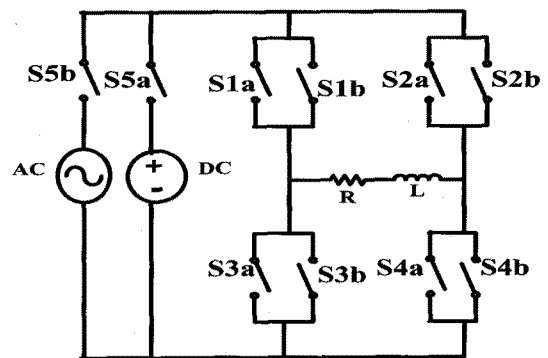

Fig. 9 Generalized SPMC with two input sources

3.3 Logical Operator

After generation of basic signals, the output control signals for a particular converter operation are synthesized in the logical operator. For example, to enable the function of the cyclo-converter in a generalized converter, first output signal Y4 of the decoder has to be made high while the rest of the signals will be low. Y4 is made high according to Table: 1 of combination circuits (A=1, B=0, C=0). To trigger IGBTs for cyclo-inverter operation, signals are generated by operating the logical operators on the basic signal as shown in the third column of Table 2.

3.4 Isolation and driver circuit

The pulses produced after logical operation are usually at low power levels. They may not be able to trigger the devices into conduction if fed directly. These pulses are therefore boosted to high power levels by a driver circuit. The amplified pulses are isolated using opto-coupler 4N35 and are fed to the gate of respective IGBTs.

3.5 Power Circuit

The power circuit is shown in Fig 1 where appropriate switches will conduct according to the selected converter. Thus, for example, for single quadrant chopper operation only two switches S1a and S4a will conduct while for cyclo converter or cyclo-inverter operation all eight switches will be in a conducting state depending upon the trigger pulses fed to each respective switch.

Table 2 Logical Expression of Triggering Pulse For Different converter Operation

Converter	Output Signal (Conducting Switches)	Logical Operation
Cyclo Inverter (100 Hz)	S1a, S4a	$Y4.X2.X8$
	S2a, S3a	$Y4.X3.X8$
	S2b, S3b	$Y4.X2.X9$
	S1b, S4b	$Y4.X3.X9$
Inverter	S1a, S4a	$Y7.X6$
	S2a, S3a	$Y7.X7$
Rectifier	S1a, S4a	$Y6.X4$
	S2b, S3b	$Y6.X5$
Chopper (First Quadrant operation)	S1a, S4a	$Y5.X10$
Cyclo Converter	S1a, S4a	$Y3.X11.X4$
	S2b, S3b	$Y3.X11.X5$
	S2a, S3a	$Y3.X12.X4$
	S1b, S4b	$Y3.X12.X5$

4. Simulation Results

Orcad Capture, version 9.1, software and its facilities are used to model a SPMC loaded with resistive load. The results of the simulation are reported for all types of converters representing the output voltage synthesized using the PWM/SPWM technique. Simulation results are obtained for a generalized converter by selecting the input parameters which decide the input supply and type of converter.

Fig 10 (a) shows the switching pattern for a single

phase matrix converter operated as an inverter and Fig. 10 (b) shows the output voltage across the load. Fig 11 (a) shows the switching pattern of the SPMC as a rectifier operation and Fig 11 (b) shows the output voltage across the load.

Fig. 12 shows the output waveforms when the SPMC is used as chopper. Implementation of the SPMC as a cyclo-converter requires different bi-directional switching arrangements depending on the desired output frequency. The magnitude of the output voltage is controlled by SPWM, but the frequency of the output depends on the switching algorithm.

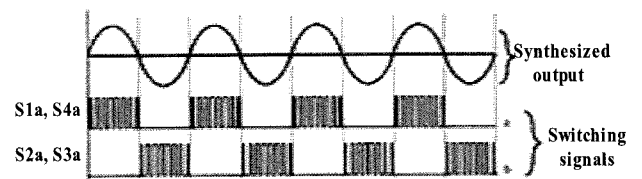

(a) Switching Pattern

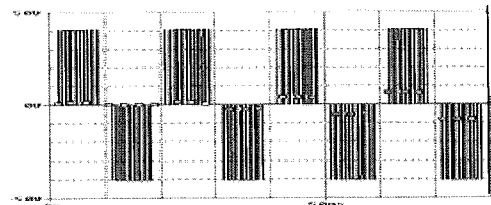

(b) Output Voltage

Fig 10 Simulated Results for Inverter Operation

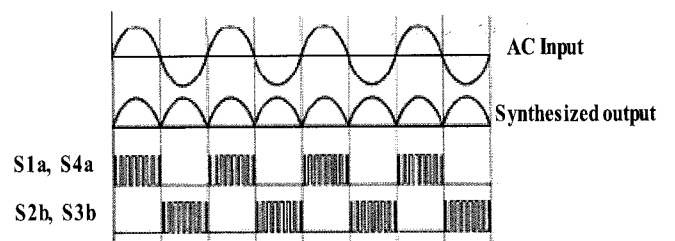

(a) Switching Pattern

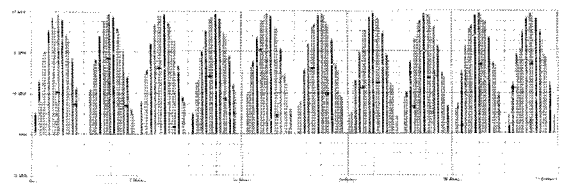

(b) Voltage Across the load

Fig. 11 Simulated Results for Rectifier Operation

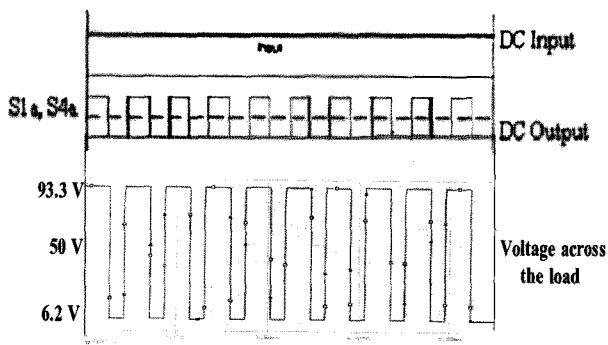

Fig. 12 Simulated Results for Chopper Operation

Fig 13 and 14 show the input, output and switching waveforms when the SPMC is used as cyclo-converter and cyclo-inverter respectively.

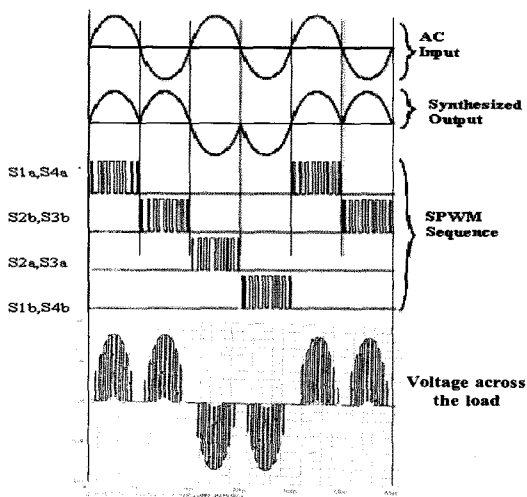

Fig. 13 Simulated Results for Cycloconverter Operation

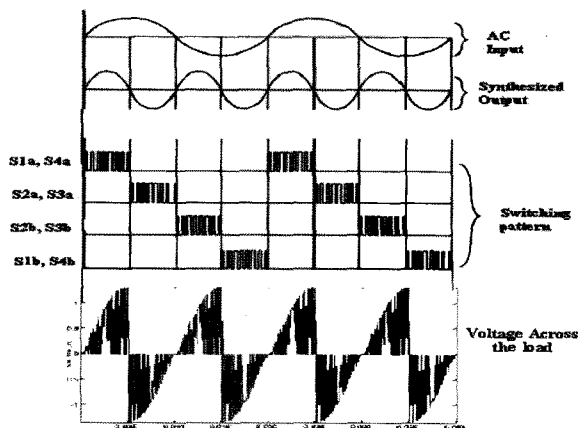

Fig. 14 Simulated Results for Cyclo-Inverter Operation

5. Experimental Results

Experimental results are obtained qualitatively by observing the waveforms on CRO at salient points of the control circuit. A variable resistance is used as a load. Fig. 15 and Fig. 16 show the trigger signals for different IGBTs for cyclo-inverter operation for $N = 2$.

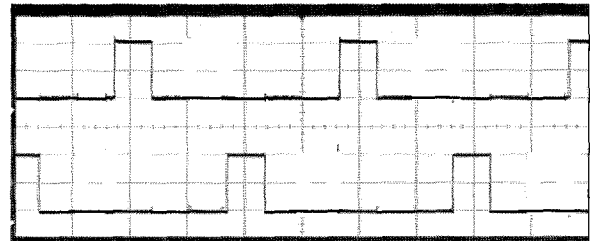

Fig. 15 Trigger signals for IGBTs S1a, S4a (upper trace: 2.5 V/div) and S2b, S3b (lower trace: 2.5 V/div) for $N = 2$

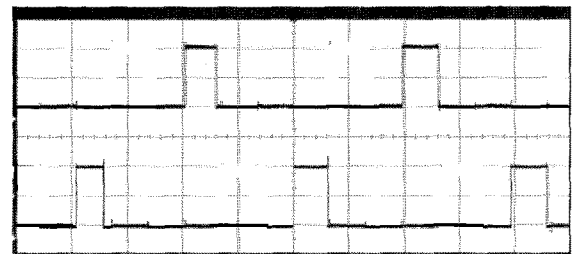

Fig. 16 Trigger signals for IGBTs S2a, S3a (upper trace: 2.5 V/div) and S1b, S4b (lower trace: 2.5 V/div) for $N = 2$

Figure 17 shows the trace of output voltage of cyclo-inverter for $N = 2$. Due to some voltage drop in the circuit the output voltage level is somewhat less than the input supply voltage level.

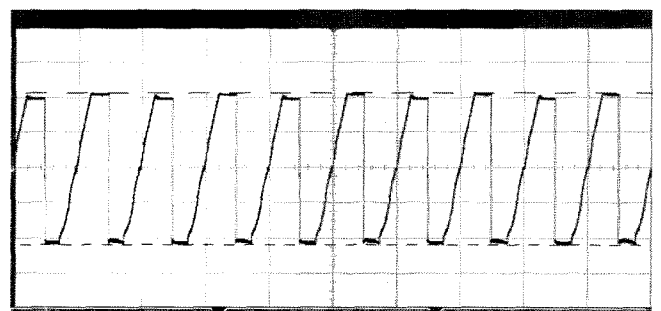

Fig. 17 Output voltage of Cyclo-inverter for $N = 2$ (50 V/div)

Trigger signals for IGBTs and the output voltage across the load for chopper operation are shown in Fig. 18

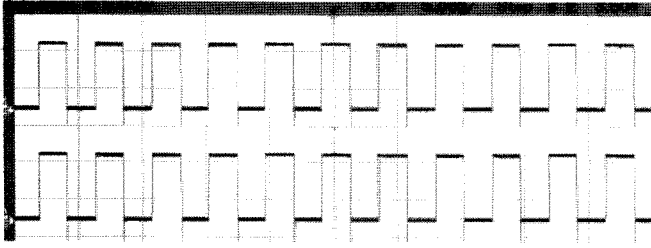

Fig. 18 Trigger signals for IGBTs S1a, S4a (upper trace: 2.5 V/div) and output voltage across the load (lower trace: 40 V/div)

6. Conclusions

It has been outlined and illustrated that the SPMC is an advanced topology that could be used to perform numerous functions in converter applications. The various general converter requirements have been modeled and realized experimentally. From results obtained it has been shown that the SPMC can have either AC or DC supply input and synthesized AC or DC output using a well-known PWM technique. The output waveform has been synthesized using Multiple Pulse Width Modulation and Sinusoidal Pulse Width Modulation. The switching algorithm presented has been implemented in computer simulation models using the Orcad capture simulation tool to illustrate its basic behaviour. Experimental results are presented for the chopper and cyclo-inverter operation.

References

- [1] Wheeler P, Clare J, Empringham L, Apap M. and Bland M., "Matrix converters", *Power engineering journal*, December 2002.
- [2] Idris Z, Hamzah M.K. and Omar A.M., "Implementation of Single-Phase Matrix converter as a Direct AC-AC Converter Synthesized Using Sinusoidal Pulse Width Modulation with Passive Load Condition", Proc. of IEEE Sixth International Conference PEDS 2005, Kuala Lumpur, Malaysia, pp.1536-1541, 2005.
- [3] Noor S.Z.M, Hamzah M.K. and Abidin A.F., "Modelling and Simulation of a DC Chopper Using Single Phase Matrix Converter Topology", Proc. of IEEE Sixth International Conference PEDS 2005, Kuala Lumpur, Malaysia, pp. 827-832, 2005.
- [4] S.,Hamzah M.K., "Modelling and simulation of a single-phase AC-AC matrix converter using SPWM", Proc.of student Conference on Research and Development, SCOREd 2002, pp. 286-289, July 2002.
- [5] Wheeler, P.W., Clare, J.C., Empringham, L., Bland, M. and Kerris, K.G., "Matrix converters", *IEEE Industry Applications Magazine*, pp. 59 -65, Jan-Feb 2004.
- [6] Wheeler, P.W., Rodriguez, J., Clare, J.C., Empringham, L. and Weinstein, A., "Matrix converters: a technology review", *IEEE Transactions on Industrial Electronics*, pp. 276 – 282, April 2002.
- [7] Zuckerberger A., Weinstock, D.and Alexandrovitz A., "Single-phase Matrix Converter", *IEE Proc. Electric Power App.*, pp. 235-240, July 1997.
- [8] Idris Z, Hamzah M.K. and Saidon M.F., "Implementation of Single-Phase Matrix Converter as a Direct AC-AC Converter with Commutation Strategies", Proc. of 37th IEEE Power Electronics Specialists Conference, PESC '06 , pp.1 – 7, 18-22 June 2006.
- [9] Idris Z, Noor S.Z.M. and Hamzah M.K., "Safe Commutation Strategy in Single-phase Matrix Converter", Proc. of IEEE Sixth International Conference PEDS 2005, Kuala Lumpur, Malaysia, pp. 886-891, 2005.
- [10] Baharom R., Hasim A.S.A, Hamzah M.K. and Omar M.F., "A New Single-Phase Controlled Rectifier Using Single-Phase Matrix Converter", Proc. of first International Power and Energy Conference PECon 2006, Putrajaya, Malaysia, pp. 453-459, November 2006.
- [11] Hamzah M.K., Noor S.Z.M, and Shukor S.F.A., "A New Single-Phase Inverter using Single-Phase Matrix Converter Topology", Proc. of first International Power and Energy Conference PECon 2006, Putrajaya, Malaysia, pp. 459-464, November 28-29, 2006.
- [12] Lettl J. and Fligl S, "PWM Strategy Applied to Realized Matrix Converter System", Proc. of PIERS Proceedings, Prague, Czech Republic, pp. 122-126, August 27-30, 2007.
- [13] Idris Z and Hamzah M.K. "Implementation of a new Single-phase Cyclo-converter based on Single-phase Matrix Converter Topology using Sinusoidal Pulse Width Modulation with Passive Load Condition", Proc. of IEEE Sixth International Conference PEDS 2005, Kuala Lumpur, Malaysia, pp. 827-832, 2005.
- [14] Hanafi H.M, Idris Z, Hamzah M.K. and Saparon A, "Modelling & Simulation of Single-phase Matrix Converter a Frequency Changer with Sinusoidal Pulse Width Modulation Using MATLAB/ Simulink", Proc. of First International Power and Energy Conference PECon 2006, Putrajaya, Malaysia, pp. 482-486, November 2006.



Ajay Kumar Gola received his B.E degree in Electrical Engineering from BMAS Engineering College in 2003. He completed his M. Tech. from Moti Lal Nehru National Institute of Technology in 2008. Presently, he is an engineer in the Power Grid Corporation of India Ltd (PGCIL). His research interests include power electronics converters, high voltage engineering and power quality.



Vineeta Agrawal graduated from Allahabad University, India, in 1980, and received her master's degree in Electrical Engineering in 1984, from the same university. She joined as lecturer in 1982 in the Electrical Engineering Department in M. N. R. Engineering College and since then she has been teaching in the same college. While teaching, she completed her Ph.D. in Power Electronics. At present she is Professor in the Department of Electrical Engineering at Moti Lal Nehru National Institute of Technology, Allahabad. She has taught numerous courses in Electrical and Electronics. Her research interests are in single phase to three-phase conversion and AC drives. She has a number of publications in journals and conferences in her field. She has attended and presented in national and international conferences..