

## Performance Evaluation of 2-Dimensional Light Source using Mercury-free Flat Fluorescent Lamps for LCD Backlight Applications

Joung-Hu Park<sup>†</sup>, Bo-Hyung Cho<sup>\*</sup>, Ju-Kwang Lee<sup>\*</sup> and Ki-Woong Whang<sup>\*</sup>

<sup>†</sup>Dept. of Electrical Eng. and Comp. Sci., Seoul National University, Seoul, Korea

### ABSTRACT

Recently, 2-dimensional flat light sources have been attracting much attention for its use in LCD backlight applications because of its high luminous efficiency and uniformity. A long-gap discharge, mercury-free flat fluorescent lamp has been developed, which shows a high brightness ( $>5000 \text{ cd/m}^2$ ) and high luminous efficacy (60 lm/W). Additionally, it has a wide operating margin and stable driving condition with the aid of an auxiliary electrode. For driving the lamp, a narrow pulse power to maintain the glow discharge state is required. Since there has been no research for this kind of lamp driving, this paper proposes a newly developed short-pulse, high-voltage lamp-driving scheme. The proposed lamp system uses a ballast with a coupled-inductor in order to raise the short pulse voltage up to the lamp ignition level and to obtain energy-recovery action during the glow discharge mode. The operation principles are presented and also the system performances such as the lighting efficiency, spatial and angular uniformities are evaluated by hardware experiments. The results show that the proposed lighting system is a good candidate for the next-generation of LCD backlight systems.

**Keywords:** Mercury-free, 2-dimensional light source, Flat fluorescent lamp, Driving circuit, Lamp ballast

### 1. Introduction

Nowadays, Liquid Crystal Display (LCD) device technology has progressed with the rapid growth of information display industries. Since LCD devices are non-emissive, a backlighting system for brightness control is necessary. Currently, CCFLs (Cold Cathode Fluorescent Lamps) are widely used for LCD backlighting systems because of its high luminous efficiency. However, as the

size of LCD displays increases, the length of fluorescent lamps increases accordingly, which causes the loss of display qualities such as loss of luminance and luminous uniformity. About 16~20 CCFLs are employed in a 32-inch LCD TV, and each lamp has a series ballast capacitor due to the negative impedance characteristic. If the lamps are driven by a single inverter, then there exists an unbalanced current in the parallel driving <sup>[1]</sup>. Furthermore, the temperature dependency of the luminous characteristics is very hard to control at low temperatures. In addition, the Mercury component is an environmentally hazardous material <sup>[2]</sup>.

In order to overcome restrictions in current backlighting technologies, many researches have suggested new ideas

Manuscript received Nov. 10, 2008; revised Jan. 13, 2009

<sup>†</sup>Corresponding Author: whoishe@snu.ac.kr

Tel: +82-2-880-1785, Fax: +82-2-878-1452, Seoul Nat'l Univ.

<sup>\*</sup>Dept. of Electrical Eng. and Comp. Sci., Seoul National Univ., Korea

for the next generation of lighting technology. The conventional ‘dot’ light sources (0-dimensional lamp) and ‘tubular’ light sources (1-dimensional lamp) commonly have brightness uniformity problems. Therefore, light-wave guides, reflectors and diffusers are employed even though they degrade the luminous efficacy and increase the cost. In general, losses due to the reflector/collector, diffusers, and any additional filters amount to un-negligible portion of the light energy emitted by the lamps<sup>[3]</sup> and they become more severe as the display size increases. The desirable next-generation lamps, therefore, would have better luminous efficiency than those of conventional ones without the use of reflectors or diffuser sheets<sup>[3]</sup>.

As an alternative solution, a few 2-dimensional, Mercury-free flat fluorescent lamps (MFFLs) have been suggested<sup>[4-7]</sup>. However, these lamps require more technical improvements in luminance and luminous efficiency to replace conventional Mercury-containing fluorescent lamps. Recently, an MFFL with a long-gap was reported to have very high luminous efficiency and a luminance more than 60 lm/W and 5000 cd/m<sup>2</sup>, respectively<sup>[2,8]</sup>. It uses Ne-Xe mixed gas generating the dielectric barrier discharge between a pair of parallel-running, dielectric-covered electrodes in a 4.1-inch diagonal base unit (see Fig. 1). The lamp size can be enlarged to any hyper size by repetition of the base cell unit<sup>[9-12]</sup>. In this paper, a backlighting system employing this flat panel is proposed. It is driven by a newly-developed lamp driver for high-voltage pulse generation. The driving inverter provides the pulse power for maintaining the glow discharge in the lamp and achieves a high system-efficiency through adopting an energy-recovery function. The driver is made to be as simple as possible to decrease the product cost. In the following sections, a simple introduction to the Mercury-free FFL will be presented, which is followed by the operation analysis and performance evaluation of the proposed driving circuit.

## 2. Opto-Electronic Characteristics of Mercury-Free Flat Fluorescent Lamps

The newly developed MFFL utilizes a plasma discharge

generation between the dielectric covered electrodes. Fig. 1(a) shows the structure of the unit Dielectric Barrier Discharge (DBD) lamp panel<sup>[2]</sup>. Sustaining electrodes are covered by an 80  $\mu\text{m}$  thick dielectric layer, and are separated 70 mm from each other. The total pressure of the Ne-Xe mixture was varied from 10 to 110 Torr with 2~7% Xe concentration<sup>[2]</sup>. The discharge is generated and sustained by bi-directionally alternating short pulse voltages (Fig. 1(b)). The lower limit of the peak of the pulse (see  $V_L$  in Fig. 4(e)) for the normal lamp operation is the minimum voltage for the sustain conditions to generate the glow discharge. The upper limit ( $V_H$  in Fig. 4(e)) is the voltage at which the diffused glow discharge transfers to contracted state. The normal lamp driving voltage margin exists between the two limits.

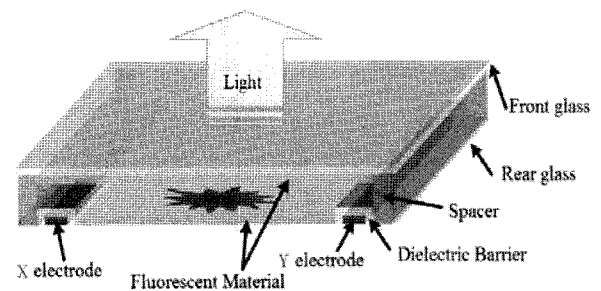

(a) Structure of the unit lamp

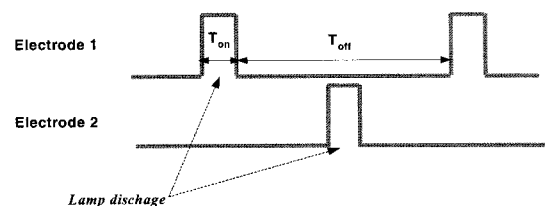

(b) Driving pulse waveforms for the lamp

Fig. 1 Structure of the flat light source panel and the driving pulses<sup>[2,12]</sup>

When the driving voltage arrived at the gas break-down voltage, local discharge starts to occur, and they expand to the whole panel as the applied voltage increases. Within the normal voltage margin, the diffused glow discharge is maintained and shows a uniform luminance<sup>[2]</sup>. The basic operation principles are as follows<sup>[6]</sup>:

- Some charges excited by the driving voltage, called ‘wall charge’, move to the electrodes and are accumulated on the dielectric surfaces inducing an E-field opposite to the external voltage.
- As the wall charges develop, the net field becomes smaller.
- When the driving voltage returns to ground, a second discharge of an opposite polarity ignites due to the large amount of the wall charge.
- When all the wall charges have dissipated, the discharge terminates.

Usually, the condition of the diffused glow discharge is influenced by a few factors, like the input power, gas conditions, or discharge volume geometry etc.<sup>[9]</sup>. An excessive perturbation changes the diffused glow discharge to a contracted state, and prevents it from having uniform emissions with high luminous efficiency. Newly suggested MFFLs show wide operating margins due to the auxiliary electrodes and the long-gap discharge. Fig. 2 shows the lamp’s efficiency and brightness performance curves according to the driving voltage variation<sup>[8]</sup>. Luminance is enhanced from 3000 cd/m<sup>2</sup> to 6000 cd/m<sup>2</sup> as the driving voltage increases from 1.85 kV to 2.15 kV. However, the increase of the voltage causes the discharge efficacy to decrease below 50 lm/W.

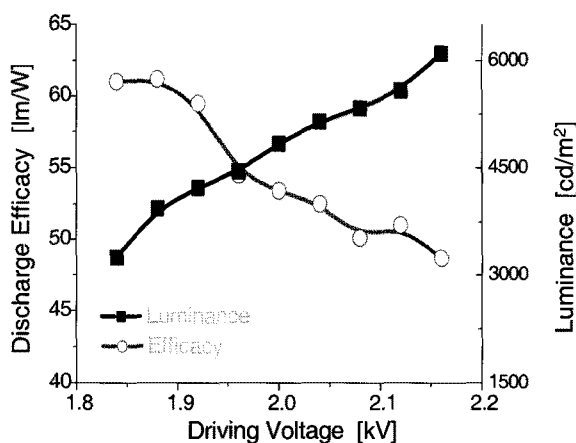

Fig. 2 The opto-electronic characteristic of high Xe content (Pulse width/interval = 1.5us/75us)

### 3. Operation Principles of the MFFL Backlighting System

Since this lamp requires narrow voltage-pulse with a flat top over 1 kV, a transformer type (coupled-inductor) ballast is suggested. Fig. 3 shows the inverter circuit configuration to drive the MFFL<sup>[13]</sup>. For the bi-polar lamp driving, the inverter circuit is composed of dual parts which have 180° phase shift of the operating modes from each other (see Fig. 4(e)).

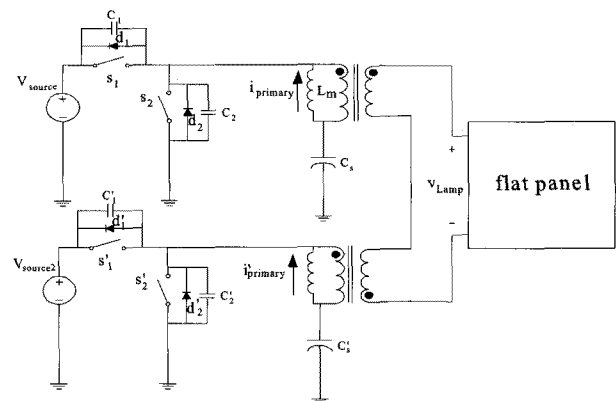

Fig. 3 Bi-directional MFFL driving circuit

Since this lamp requires narrow voltage-pulse with a flat top over 1 kV, a transformer type (coupled-inductor) ballast is suggested. Fig. 3 shows the inverter circuit configuration driving the MFFL<sup>[13]</sup>. For bi-polar lamp driving, the inverter circuit is composed of dual parts which have 180° phase shift of the operating modes from each other (see Fig. 4(e)).

Since the lamp starts to show the glow discharge at several hundred volts, the coupled inductor in the circuit boosts the pulse voltage generated by switching devices in the primary side (S<sub>1</sub>, S<sub>2</sub>, S<sub>1</sub>’, S<sub>2</sub>’ in Fig. 3) up to the required lamp voltage level. The secondary windings of the two inductors are series-connected and the coupling direction is opposite in order to give both positive and negative voltage to the lamp electrodes as shown in Fig. 4(e). The simple circuit structure would give cost and size competitiveness. It also provides the energy-recovery operation necessary for high luminous efficiency in all capacitive load applications. The impedance of the lamp is nearly capacitive during the voltage transition mode.

The operational principles and the key waveforms of each mode are presented in Fig. 4, while detailed descriptions are as follows:

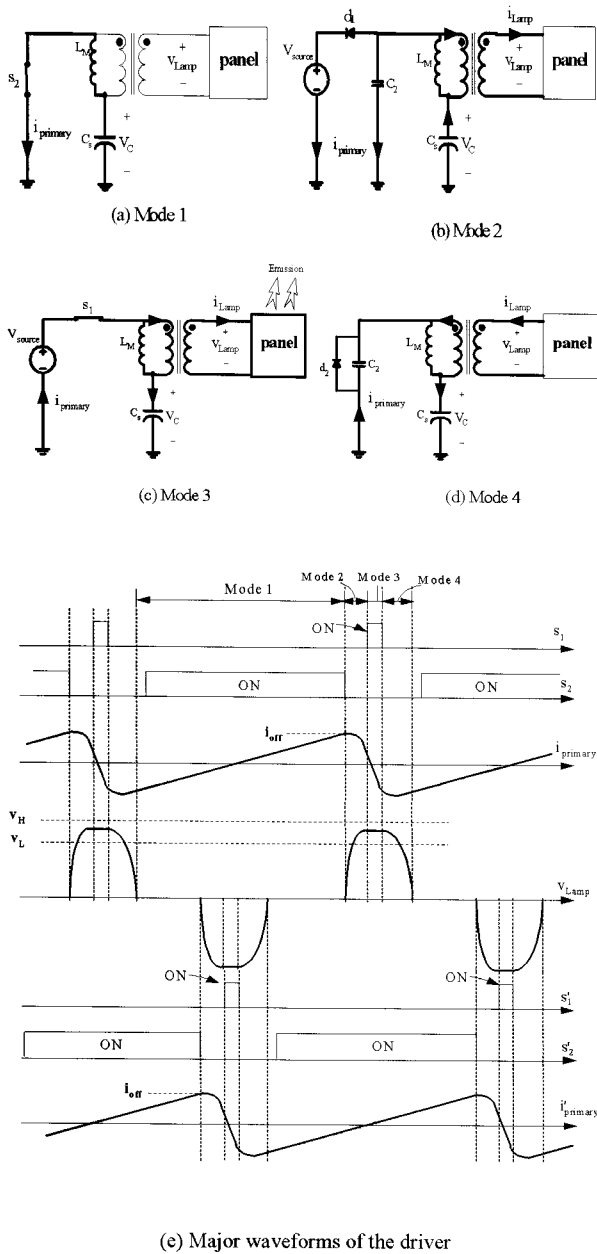

Fig. 4 Operation mode analysis and the major waveforms of the driving circuit

**Mode 1:** Bottom switch ( $S_2$ ) is on. The primary magnetizing current ( $i_{primary}$ ) increases and the capacitor ( $C_s$ ) starts to discharge (see Fig. 4(a)).

**Mode 2:** Bottom switch ( $S_2$ ) turns off. The current ( $i_{off}$ ) boosts lamp voltage  $V_{Lamp}$  and ignites the lamp. The lamp starts to dissipate the inductor energy for lighting and  $V_{Lamp}$  is clamped by  $V_{source}$  through an anti-parallel diode

( $d_1$ ) (see Fig. 4(b)).

**Mode 3:** Since the anti-parallel diode first turns on before the top switch ( $S_1$ ) is on, zero-voltage switching is achieved. The magnetizing inductor current changes direction and starts to flow through  $S_1$ .  $C_s$  starts to charge. The reflected secondary current is utilized for glow discharge of the lamp (see Fig. 4(c)).

**Mode 4:** The top switch ( $S_1$ ) turns off. The lamp is extinguished, and the remaining capacitive energy in the lamp is recovered to  $C_s$  through the coupled inductor (see Fig. 4(d)).

In order to show the performance of the proposed MFFL backlighting system, prototype hardware was implemented. Fig. 5 shows the 6-cell MFFL in stable glow discharge. Some dark lines appear between the adjacent cells inside the panel by the barrier rib. However, very small amounts of diffusers are enough to remove the pattern. For the advanced study of this panel, the manufacturing process is still being studied for the thinner ribs, and the possibility of a transparent barrier rib is being examined as well<sup>[14]</sup>.

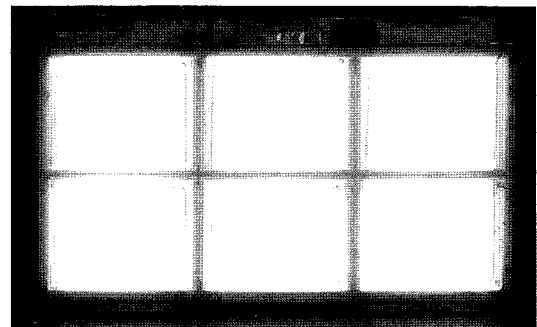

Fig. 5 A photo of 6-cell MFFL in stable glow discharge

#### 4. System Efficiency

Fig. 6 shows the measured key waveforms. In Fig. 6(a), the lamp voltage is a short pulse less than  $2\mu s$  width, and there is some high frequency oscillation on the top of the pulse caused by the parasitic components of the coupled-inductors, lamps and the connectors. In order to reduce the parasitic oscillation, the coupled inductor should be implemented with small leakage inductance as much as possible. This ringing is also shown in the lamp

current waveform. However, the energy-recovery action is noticeable in the charging and discharging lamp current during the voltage transition modes. When  $S_1$  is on, the power source provides the lamp with a discharge current through  $S_1$  in a very short time less than  $1 \mu s$ .

In Fig 6(b), the long-term waveforms are shown. It is shown that the  $180^\circ$  phase-shift between the modules resulted in the symmetric bi-polar voltage and current waveforms in the lamp. The waveforms agree well with those of Fig. 4 through the same gating sequence.

The system-efficiency measurement results are shown in Fig. 7. Abscissa is the switching frequency and ordinate is the luminous efficiency (lm/W) including the power consumed by the inverter and the MFFL. Input power was measured at the input terminal of the inverter by a digital power meter WT-210 (Yokogawa) and the output luminance was measured by a chroma meter CS-200 (Konica-Minolta). The efficiency was measured at  $2500 \text{ cd/m}^2$  luminance with 2 (1 by 2), 4 (2 by 2), 6-panels (2 by 3), respectively.

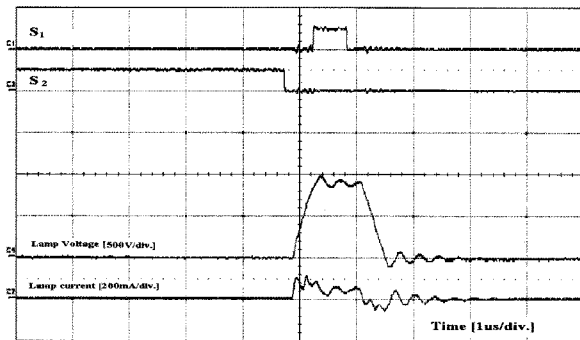

(a) Measured single pulse waveform

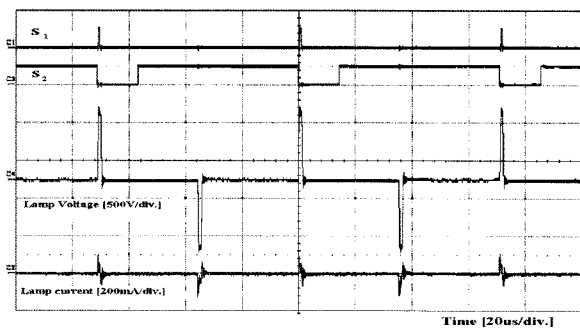

(b) Long-term waveform

Fig. 6 Major waveform of the hardware experiment

It is shown that as the load increases, the system efficiency becomes greater, and the maximum point is  $36 \text{ lm/W}$ . This high luminous efficiency results from the energy-recovery and soft-switching actions of the driver. Influence of the switching frequency seems insignificant to the system performance in 4 and 6 cell lamps. Fig. 8 shows the input voltage range of the MFFL driver according to the operating frequency variations. The normal input range starts with ignition and is limited by arc discharge. It is shown that the ignition voltage and the operating range span decreases as the frequency increases.

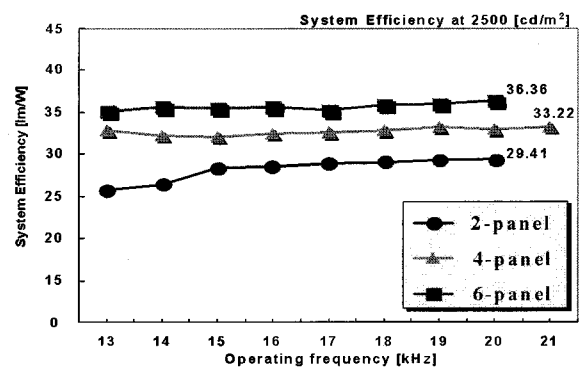

Fig. 7 System efficiency of the MFFL

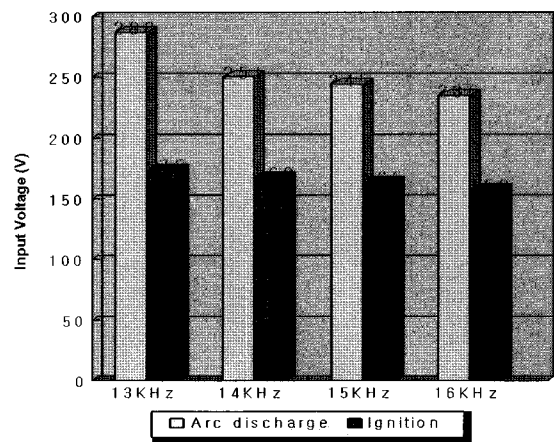

Fig. 8 Operating frequency vs. Input voltage (at  $2500 \text{ cd/m}^2$ )

### 5. Luminance Uniformity

Luminance uniformity is another critical factor in LCD backlight systems. A human factor study reported that

non-uniformity exceeding 15-20% can be recognized by users and it makes them feel uncomfortable<sup>[15]</sup>. In this section, the brightness uniformity of the proposed 2-D light source is examined. The measurement setup is shown in Fig. 9(a). The entire display surface is divided into 54 sections (9 sections / cell) and the brightness of each section is measured. The measurement was performed twice for a 110 Vrms input system and 220 Vrms input system (Korea standard).

The experimental results are shown in Fig. 9(b) to 9(d). In the case of 110 V, the maximum brightness is 2113 cd/m<sup>2</sup>, located at X=3, Y=5, and the minimum is 1621 cd/m<sup>2</sup>, located at X=1, Y=1. From the data, the brightness uniformity of the MFFL is 77% without use of diffusers. Fig. 9(c) shows a 3-D representation of the luminance distribution shown in Fig. 9(b). In the case of 220 V, the results represent better performance as shown in Fig. 9(d). The MFFL shows good brightness uniformity of 80%. The maximum brightness 4466 cd/m<sup>2</sup> is located at X, Y coordinates (3,5), and the minimum brightness is 3604 cd/m<sup>2</sup>, located at (3,1). The maximum-minimum brightness deviation is less than 900 cd/m<sup>2</sup>. Fig. 9(e) shows a 3-D representation of data given by Fig. 9(d). Of course, the uniformity will be improved when a diffuser is employed for this light source. The experimental results are summarized in Table 1.

Table1 Summary of the uniformity measurements without using of a diffuser

Voltage	110V	220V
Average	1880	4061
Max.	2113	4542
Min.	1621	3604
Uniformity	77%	80%

### 6. Viewing Angle

Another important illuminating factor for LCD backlight applications is angular uniformity. In this

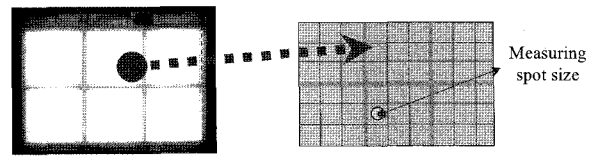

(a) Measuring position for MFFL uniformity

	1	2	3	4	5	6	7	8	9
1	1673	1763	1835	1750	1807	1984	1925	1879	
2	1876	1768	1890	1963	1860	2022	2028	1937	1885
3	1656	1777	1844	1956	1764	1985	1831	1915	1735
4	1876	1982	2089	1692	1836	1982	1838	1810	1948
5	1952	1993	1892	1907	1913	1803	1856	2005	
6	1866	1925	2020	1873	1929	2082	1784	1783	1836

(b) Luminance distribution data (cd/m<sup>2</sup>) at 100 Vrms input

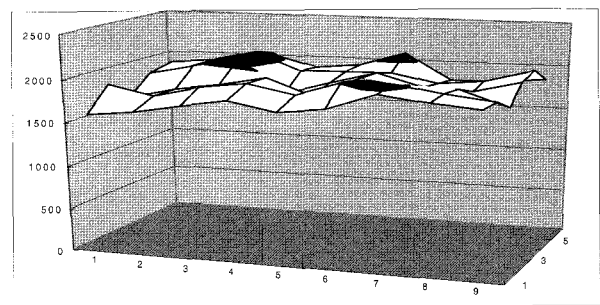

(c) 3-D presentation of the luminance distribution in (b)

	1	2	3	4	5	6	7	8	9
1	3890	3706	3604	4280	4109	3926	4388	4288	3999
2	4082	3956	3798	4491	4333	4190	4542	4341	4105
3	3879	3785	3716	4425	4265	4064	4248	4113	3802
4	3852	4154	4419	3803	4170	4193	3742	3975	4151
5	3887	4172	4466	3826	4243	3700	3779	4040	4226
6	3690	4075	4317	3819	4170	4375	3716	3856	4147

(d) Luminance distribution data (cd/m<sup>2</sup>) at 220 Vrms input

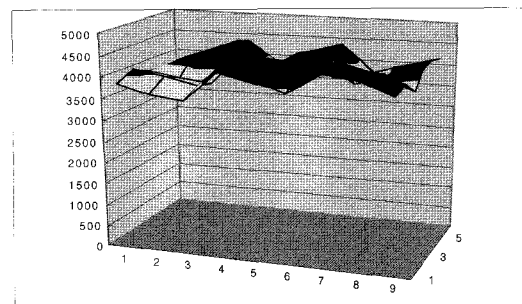

(e) 3-D presentation of the luminance distribution in (d)

Fig. 9 Experimental results of the luminance uniformity measurements

section, two test categories are examined such as luminance angular uniformity and color temperature uniformity. Fig. 10 shows the experiment setup. In the experiment, both the MFFLs and white LED lamps are tested for comparison. The viewing angle includes vertical (longitude) angle and horizontal (transverse) angle as shown in Fig. 10(b). For improvement of angular uniformity, a diffuser is employed in front of the LED lamp.

Fig. 11 is the experimental results of the luminance variation according to viewing angle. In Fig. 11(a), the vertical angle luminance of the MFFL is almost constant at 3800 cd/m<sup>2</sup> level, however the horizontal angle luminance varies from 3800 cd/m<sup>2</sup> to 3100 cd/m<sup>2</sup> as the angle changes from 0° to 80°. Local zooming of the MFFL curves are shown in Fig. 11(b) indicating that the variation rate is 19%. The difference between the vertical and horizontal direction may come from the edge effect. In the case of the LED lamp, the horizontal angle luminance varies down from 2100 cd/m<sup>2</sup> to 1600 cd/m<sup>2</sup> as the angle changes from 0° to 80°. In comparison, both the white LED and MFFL show similar angular uniformity with very wide viewing angle.

Fig. 12 shows the color temperature variation according to viewing angle. In Fig. 12(a), the MFFL color temperature keeps an almost constant level of 5600 K in both vertical and horizontal angles. However, the LED lamp's color temperature rises up from 13000 K to 14500 K as the angle changes from 0° to 80°. Local zooming of the MFFL curves are shown in Fig. 12(b). From the figure, it can be seen that the red, green, and blue components are reduced at the same rate even as the angle changes. The experimental results are summarized in Table 2. From these experiments, it is shown that the 2-D flat lamp system demonstrates excellent performance not only in spatial uniformity but also in angular uniformity.

### 7. Conclusions

Table 2 Experimental result summary of the MFFL uniformity measurements according to viewing angle variation

Angle	0°	30°	70°	80°
Luminance	100%	99.1%	89.1%	80.9%
Color Temp.	100%	100%	99.0%	99.0%

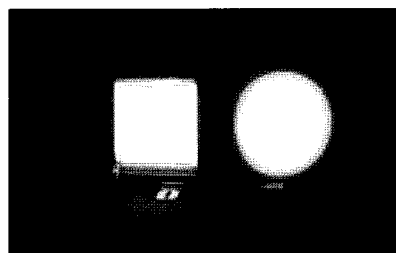

(a) Photograph of MFFL (left) and white LED lamp with diffuser (right)

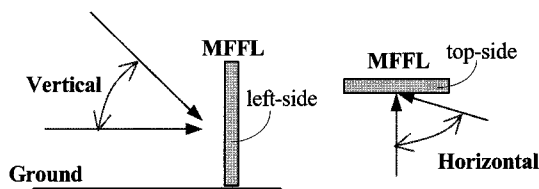

(b) Vertical (longitude) angle and horizontal (transverse) angle

Fig. 10 Experimental setting of viewing angle measurement

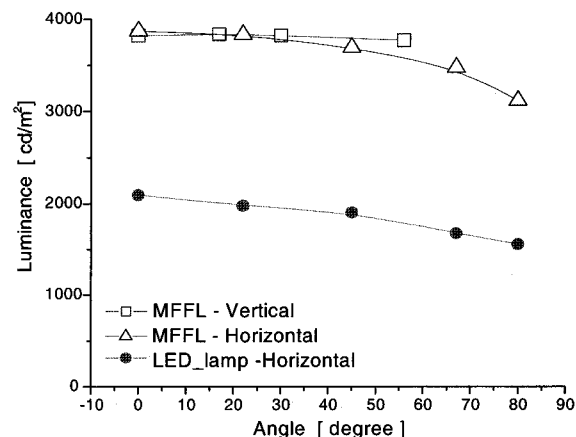

(a) Luminance variation according to the viewing angle

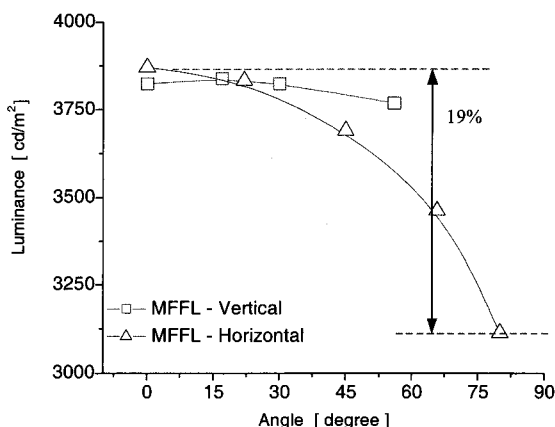

(b) Local zooming of MFFL luminance curves in (a)

Fig. 11 Experimental results of the luminance measurements according to the viewing angle

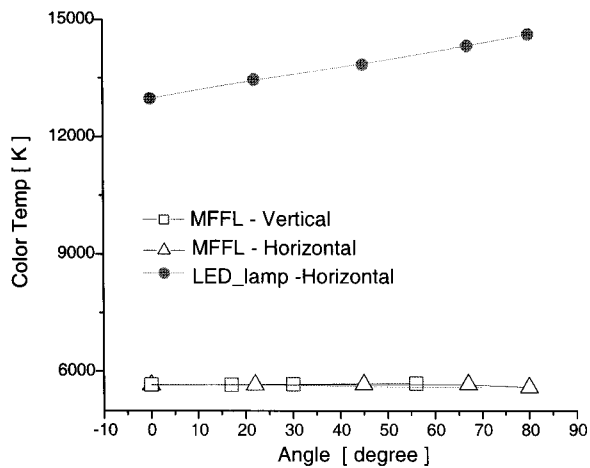

(a) Color temperature variation according to the viewing angle

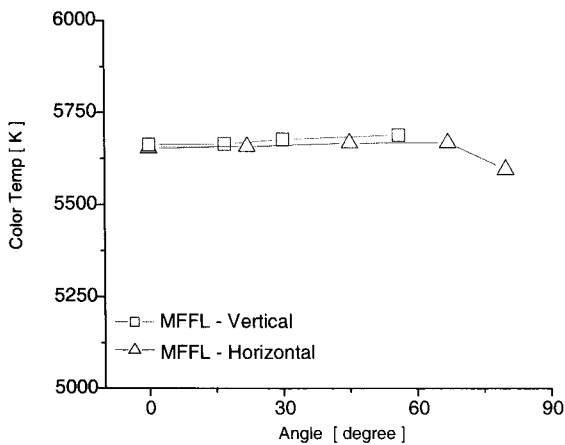

(b) Local zooming of MFFL color temperature curves in (a)

Fig. 12 Experimental results of the color temperature measurements according to the viewing angle

This paper has proposed a 2-dimensional, Mercury-free flat fluorescent lamp system for LCD backlight applications. The long-gap discharge flat fluorescent lamp shows excellent luminous efficacy with the newly-developed driving circuit. The inverter's operation principles for driving the flat panel with energy-recovery function were presented and the performances were verified by hardware experiments.

The proposed inverter circuit was applied to 2, 4, and 6-cell panels and obtained a driving system efficiency greater than 35 lm/W. The spatial and angular uniformity were also investigated and compared with those used in LED lighting systems. The luminance uniformity of MFFL is 77% and 80% at low and high luminance, respectively, and the viewing angle is also very wide.

## Acknowledgment

The authors are thankful for the technical support from Dr. In-kyu Lee in the R&D Lab. of Sam-Hwa Yang-Heng Co. LTd., Dohwa-dong, Mapo-gu, Seoul, Korea.

## References

- [1] Kyu-Min Cho, Won-Sik Oh, Gun-Woo Moon, Mun-Soo Park, Sang-Gil Lee, "A Study on the Equivalent Model of an External Electrode Fluorescent Lamp Based on Equivalent Resistance and Capacitance Variation", *J. Power Electronics*, Vol.7, No.1, pp. 38 ~ 43, 2007.
- [2] Ju kwang Lee, Tae Jun Kim, Hae youn Jeong and Ki-Woong Whang, "High efficiency Mercury-free flat light source for LCD Backlighting", *SID 05 Digest*, pp. 1309-1311, 2005.
- [3] R. Hicks, W. Halstead, "Flat fluorescent lamp technology for LCD's", *Digital Avionics Systems Conference*, 13th DASC., pp. 630 - 635, 1994.
- [4] S. Mikoshiba, "Xe discharge Backlights for LCDs", *SID 01 Digest*, pp. 286-289, 2001.
- [5] M. Ilmer, R. Lecheler and M. Seibold, "Efficiency Enhancement of Hg-free Fluorescent PLANON Backlights by CAF", *IDW '99*, pp. 1107-1108, 1999.
- [6] T. Shiga, S. Mikoshiba and S. Shinada, "No-Mercury Flat discharge Lamp for LCD Backlighting", *IDW '99*, pp. 347-350, 1999.
- [7] Y. Ikeda, T. Shiga, S. Mikoshiba, "Mercury-Free, Simple-Structured Flat discharge LCD Backlights Ranging from 0.5 to 5.2-in. Diagonals", *SID 00 Digest*, pp. 938-941, 2000.
- [8] Ju kwang Lee, Byungjoo Oh, Jaechul Jung, and Ki-Woong Whang, "High luminous efficiency Mercury-free flat light source for LCD BLU", *IMID 05 Digest*, pp. 1161- 1164, 2005.
- [9] Yuri P. Raizer, *Gas discharge physics*, Springer-Verlag, pp 214~244, 1991.
- [10] Ju kwang Lee, Jaechul Jung, Byungjoo Oh, Inwoo Seo, Joongkyun Kim and Ki-Woong Whang, "The Electro-optic Characteristics of MFFL", *SID 06 Digest*, pp. 1422-1424, 2006.
- [11] Jounghu Park, Jong-Bok Baek, Bo-Hyung Cho, "Electrical Feedback Control for Driving a Mercury-free Flat Fluorescent Lamp", *Journal of the SID*, Vol. 16, No. 2, 2008.
- [12] Jong-Bok Baek, W. S. Kim, Jounghu Park, Bo-Hyung



Cho, "New ignition method of the MFFL-driving circuit", proceedings of the KIEE EMECS Annual Spring Conference, pp. 116-118, 2008.

- [13] J. H. Park, I. K. Lee, B. H. Cho, J. K. Lee, and K. W. Whang, "High Efficiency Inverter Systems for Driving Mercury-free Flat Fluorescent Lamps", PCC2007, pp.717-719, 2007.
- [14] Eizaburo Watanabe, Naoto Ohno, Katsumi Ohira, Junichi Arai, Isao Kato, Yasumasa Akimoto, Ikuma Nishimura, Takao Minato, Ryujichi Nakamura, "Plasma display panel, manufacturing method and manufacturing apparatus of the same", US Patent 6632116, Oct. 14 2003.
- [15] Robin M. Merrifield and Louis D. Silverstein, "The development and evaluation of color systems for airborne applications: Fundamental visual, Perceptual, and display system considerations", Report Number NADC-86011-60, 1986.



**Jung-Hu Park** was born in Korea 1975. He received his B.S, M.S., and Ph.D. degrees from the Electrical Engineering and Computer Science department of Seoul National University, Seoul, South Korea in 1999, 2001, and 2006, respectively. He is currently a post doctoral researcher in Seoul National University. His interests include analysis and design of high-frequency switching converters, renewable energy systems, and piezoelectric transformer power applications.



**Bo-Hyung Cho** was born in Korea 1952. He received his B.S. and M.E. degrees in Electrical Engineering from California Institute of Technology, Pasadena. He received his Ph.D. also in Electrical Engineering, from Virginia Polytechnic Institute and State University (Virginia Tech), Blacksburg. Prior to his research at Virginia Tech, he worked for two years as a technical staff member in the Power Conversion Electronics Department, TRW Defense and Space System Group. He was involved in the design and analysis of spacecraft power processing equipment. From 1982 to 1995, he was a professor in the Department of Electrical Engineering, Virginia Tech, Blacksburg, Virginia. He joined the school of Electrical Engineering, Seoul National University, Seoul, Korea in 1995 and he is presently a professor. His main research interests include power electronics, modeling, analysis and control of spacecraft power processing equipment, power systems for space station and space platform, and distributed power systems.



**Ju-Kang Lee** received his B.S degree from Inha University in 1996 and worked as a display device research engineer in Samsung SDI R&D division from 1998 to 2001. He is currently pursuing his Ph.D. in Electronic Engineering at Seoul National University after receiving his M.D. in 2004. He is currently studying plasma discharge in various display devices or light sources.

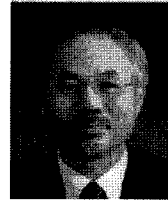

**Ki-Woong Whang** received his B.S. degree in Applied Physics from Seoul National University, Seoul, in 1972. He received his M.S. and Ph.D. degrees in Physics from UCLA, USA in 1976 and 1981, respectively. He has been a professor in the School of Electrical Engineering, Seoul National University since 1982. He has broad interests regarding plasma applications, especially plasma display panels.