

금속이온이 치환된 설폰화된 6FDA계 폴리이미드 막의 기체 투과 특성

임현수 · 이병성 · 이보성 · 윤석원* · 고희철** · 이충섭** · 하성용** · 정성일 · 임지원†
한남대학교 대덕밸리캠퍼스 나노생명화학공학과, *전력연구원 녹색성장연구소, ** (주)에어레인
(2009년 5월 26일 접수, 2009년 7월 6일 수정, 2009년 7월 13일 채택)

Gas Permeation Properties of Sulfonated 6FDA-Based Polyimide Membranes Exchanged with Metal Ions

Hyeon Soo Im, Byung Seong Lee, Bo Sung Lee, Seok Won Yoon*, Hyung Chul Koh**,
Choong Sub Lee**, Seong Yong Ha**, Seong Ihl Cheong, and Ji Won Rhim†

Department of Chemical Engineering, Hannam University,
461-6 Jeonmin-dong, Yuseong-gu, Daejeon 305-811, Korea
*Korea Electric Power Research Institute, Green Growth Laboratory,
65 Munji-ro, Yuseong-gu, Daejeon 305-380, Korea

**Airrane Co., Ltd., 217-2, Shinsung-dong, Yuseong-gu, Daejeon 305-805, Korea

(Received May 26, 2009; Revised July 6, 2009; Accepted July 13, 2009)

초록: 설폰화된 6FDA 계열의 폴리이미드의 설폰산기에 1가 이온(Li^+ , Na^+ , K^+)과 2가 이온(Mg^{2+} , Ca^{2+} , Ba^{2+}) 이 치환되어졌으며, 이러한 금속이온의 치환효과가 CO_2 , O_2 및 N_2 등의 기체 투과도와 선택도에 미치는 영향에 대하여 조사하였다. 설폰화된 폴리이미드의 열적 안정성이 금속이온을 치환함으로써 향상된 것을 열중량기 분석을 통하여 확인되었다. 1가 이온으로 치환된 막의 투과도는 이온반경 [Li^+ (0.059 nm) > Na^+ (0.102 nm) > K^+ (0.138 nm)]의 순서로 감소하며, 2가 이온의 경우 이온반경과 고분자와 금속이온 간의 전기적 가교로 인하여 결정되어짐을 알 수 있었다. 반면에, 금속이온으로 치환된 설폰화된 폴리이미드 막의 선택도는 치환되지 않은 막에 비하여 향상된 것을 알 수 있었다. K^+ 이온으로 치환된 설폰화된 폴리이미드 막의 산소 투과도는 89.98 Barrer [$1 \times 10^{-10} \text{ cm}^3(\text{STP}) \text{ cm/cm}^2 \cdot \text{s} \cdot \text{cmHg}$]을 나타내어 원래의 폴리이미드 막의 산소 투과도인 126.5 Barrer 보다 현저히 줄었으며, Li^+ 으로 치환된 막의 O_2/N_2 선택도는 12.9를 나타내어 원래의 4.2보다 크게 향상되어졌다.

Abstract: Sulfonic acid of the sulfonated 6FDA-based polyimides were exchanged with the monovalent (Li^+ , Na^+ and K^+) and divalent (Mg^{2+} , Ca^{2+} and Ba^{2+}) ions. The effect of metal cations exchanged sulfonated polyimides was investigated in terms of gas permeability and selectivity for CO_2 , O_2 and N_2 gases. Thermogravimetric analysis showed that thermal stability of sulfonated polyimide was improved by exchanged metal cations. The permeabilities of monovalent cation-exchanged, sulfonated polyimide were reduced as the ion radius reduced [Li^+ (0.059 nm) > Na^+ (0.102 nm) > K^+ (0.138 nm)], and those of divalent cations exchanged were determined by the ionic radii and electrostatic crosslinking between the polymer and metal cations, whereas the selectivities of all the metal cation-exchanged, sulfonated polyimides for CO_2/N_2 and O_2/N_2 were higher than those of sulfonated polyimide membranes. The sulfonated polyimide exchanged with the potassium cation showed the O_2 permeability of 89.98 Barrer [$1 \times 10^{-10} \text{ cm}^3(\text{STP}) \text{ cm/cm}^2 \cdot \text{s} \cdot \text{cmHg}$] and the sulfonated polyimide exchanged with the lithium cation showed the O_2/N_2 selectivity of 12.9.

Keywords: gas separation, metal ions, sulfonation, 6FDA-DAM, polyimide.

Introduction

The gas separation process by polymer membranes has used commercially to separate O_2/N_2 , CO_2/N_2 , H_2/N_2 and H_2/CH_4

during the past several decades.¹ Specifically, polyimide membranes represent a very interesting polymer because of their excellent thermal, mechanical, and gas-transport properties.²⁻⁶ In the numerous studies of polyimide membranes, 6FDA-based polyimide membranes have been identified as attractive and promising membrane materials because they showed

†To whom correspondence should be addressed.
E-mail: jwrhim@hnu.kr

high gas permeability.^{3,7,8} As reported in the abundance of literatures, 6FDA-based polyimides have been investigated on the relationship between the different chemical structures of diamine portion and their gas permeation properties.⁹⁻¹² Furthermore, the processing or operating conditions of polyimides have been considered essentially to determine the transport properties.^{6,7,13,14}

There are a number of sulfonated polymers studied for the gas separation properties. Among others, Chen and Martin¹⁵ investigated the gas permeation properties of metal-substituted sulfonated polystyrenes. They concluded that divalent cations (Mg^{2+}) containing polystyrene showed higher selectivity than that of monovalents cation (Na^+) containing polymer due to the effect of electrostatic crosslinking. Chiou and Paul¹⁶ showed that an incorporation of sulfonated groups and metal

counterions improved selectivity of Nafion. In our previous study,¹⁷ we investigated the effect of sulfonated poly(phenylene oxide) (SPPO) containing monovalents (Li^+ , Na^+ and K^+), divalents (Mg^{2+} , Ca^{2+} and Ba^{2+}), and trivalent (Al^{3+}) counterions on the carbon dioxide and methane separation. As a result, the selectivities of SPPO increased by exchanging the sulfonated with metal cations and Mg-substituted SPPO showed higher selectivity due to electrostatic crosslinking between cations and SPPO molecules.

In this study, we synthesized sulfonated 6FDA-based polyimide and exchanged the proton of sulfonic acid groups with metal cations using monovalents (Li^+ , Na^+ and K^+) and divalents (Mg^{2+} , Ca^{2+} and Ba^{2+}). As reported in the literatures,^{9,12,18} 6FDA-based polyimides exhibit high gas permeabilities, which is attributed to the presence of bulky $-C(CF_3)_2-$ group that hinders intra-segmental mobility and disrupt inter-chain-packing and stiffen the backbone. Therefore, the aim of the study is focused on the permeation properties of metal cations exchanged sulfonated 6FDA-based polyimides using single gases such as CO_2 , O_2 , and N_2 .

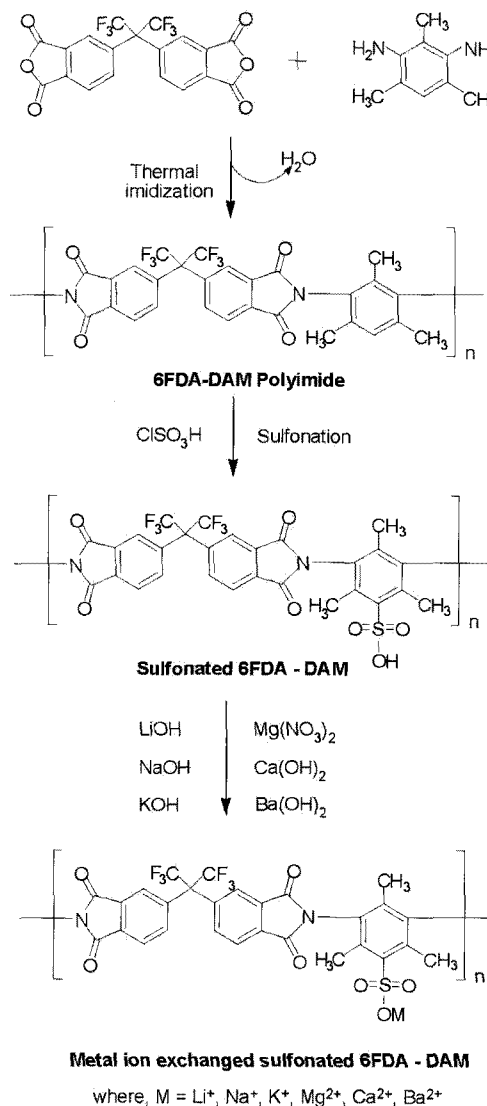

Figure 1. Reaction mechanism of metal ion exchange of sulfonated polyimide.

Experimental

Materials. Materials used in the synthesis of metal ions exchanged sulfonated polyimides included 2,2'-bis(3,4-carboxylphenyl) hexafluoropropane dianhydride (6FDA) and 4,4'-diaminodiphenylmethane (DAM). 6FDA and DAM were purchased from the Aldrich Chemical Co. (Milwaukee, WI, USA). Before polymerization, all the monomers were purified by the sublimation under reduced pressure. The solvent, *N*-methyl-pyrrolidone (Aldrich Chemical Co., Milwaukee, WI, USA) was used after drying with molecular sieve. Carbon tetrachloride (CCl_4) and chlorosulfonic acid ($ClSO_3H$) were used to synthesize the sulfonated polyimide. Other chemical reagents to produce the metal ions exchanged sulfonated polyimides, $LiOH$, $NaOH$, KOH , $Mg(NO_3)_2$, $Ca(OH)_2$, $Ba(OH)_2$ were used as received.

Synthesis of Sulfonated Polyimide. In this study, a two-stage synthesis of sulfonated polyimide was carried out. In the first stage, DAM was dissolved in NMP under a nitrogen atmosphere using a magnetic stirrer, and then, the purified 6FDA powder was gradually added to DAM solution. The reaction mixture was then stirred at room temperature to yield a viscous poly(amic acid) (PAA) solution under N_2 atmosphere. The prepared PAA solution was thermally imidized after casting onto glass plate in a vacuum oven using a four-step protocol: 60 °C for 1 h, 150 °C for 1 h, 200 °C for 1 h and 250 °C for 30 min (Sample PI). In the second stage, the polyimide membranes, with thickness of 15–20 μm were

cut to the size of the permeation cell (13.8 cm²) and then put into CCl₄ solution. Then, a stoichiometric quantity of ClSO₃H was added gradually to the CCl₄ solution with vigorous stirring. The detail preparation of sulfonated 6FDA-based polyimide (Sample SPI) was illustrated in our previous study.^{17,19}

Preparation of Metal Ions Exchanged Sulfonated Polyimide.

The metal ions exchanged sulfonated polyimide membranes were prepared by using Li⁺ (sample Li-SPI), Na⁺ (sample Na-SPI), and K⁺ (sample K-SPI) for monovalents and Mg²⁺ (sample Mg-SPI), Ca²⁺ (sample Ca-SPI), and Ba²⁺ (sample Ba-SPI) for divalents. The sulfonated polyimide membrane in proton form was immersed in a solution of alkali metal hydroxide or alkaline earth metal hydroxide of 0.1–1 N, depending on the solubility of hydroxide in water. To exchange the proton to metal cation, we immersed the sulfonated polyimide for 48 h at room temperature. Other detail illustration to prepare the metal ions exchanged sulfonated polyimide membranes was introduced in our previous study (Figure 1).^{17,19}

Gas Permeability Measurement. The gas permeation performance of metal ions exchanged sulfonated 6FDA-based polyimide membranes was measured using a single gas permeation technique²⁰ as shown in Figure 2, which diagram is based on the well-known time-lag method.²¹ The effective membrane area was 13.5 cm², and the permeation measurement was carried out at 25 °C. The error in the permeation results was less than 3%.

Gas permeability coefficients were determined from the slope of a downstream pressure versus time plot when steady-state had been reached:

$$P = \frac{dp}{dt} \left(\frac{VT_0L}{P_0T \Delta PA} \right) \quad (1)$$

where P is the permeability (Barrer = 1×10^{-10} cm³ (STP)

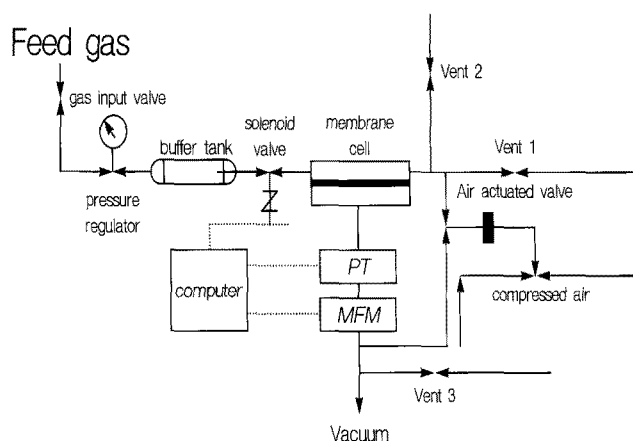

Figure 2. Gas permeation apparatus used in this study.

cm/cm² · s · cmHg) represented; the rate of the pressure rise under the steady-state (dp/dt), the down stream volume (V , cm³), the membrane thickness (L , cm), the pressure difference between the feed side and permeate side (ΔP , cmHg), the measurement temperature (T , K), the effective membrane area (A , cm²), standard pressure (P_0) and temperature (T_0), respectively. The ideal separation factor ($\alpha_{A/B} = P_A/P_B$) for component A and B is defined as the ratio of permeability of each component.

Results and Discussion

Thermal Stability of Metal Ions Exchanged Sulfonated 6FDA-Based Polyimide.

Figure 3 shows the thermal stabilities of sample PI and one of metal ions exchanged sulfonated 6FDA-based polyimide (sample Na-SPI). The sulfonic acid group ($-\text{SO}_3\text{H}$) in the polymer was decomposed between the temperature range 200–250 °C.^{22,23} As shown in Figure 3, sample Na-SPI showed approximately 5% weight loss at the temperature 350 °C, corresponding to the degradation of $-\text{SO}_3\text{Na}$. The result of increased thermal stability of metal ion exchanged sulfonic acid groups ($-\text{SO}_3\text{Na}$) compared with sulfonic acid groups ($-\text{SO}_3\text{H}$) is due to the increased intermolecular interaction through the polar ionic sites and hindrance of the chain rotation by the metal ions.²⁴

Effect of Metal Ions on the Permeability and Selectivity. The permeability, diffusion and solubility coefficients of polyimide and sulfonated polyimides are listed in Table 1. The permeabilities for CO₂, O₂ and N₂ gases through sulfonated polyimide were lower than those of polyimide. It is well agreed with the reported in the literatures for sulfonated polyimide based on 6FDA.^{25,26} On the other hand, sample SPI showed higher CO₂/N₂ and O₂/N₂ selectivities than those of sample PI as

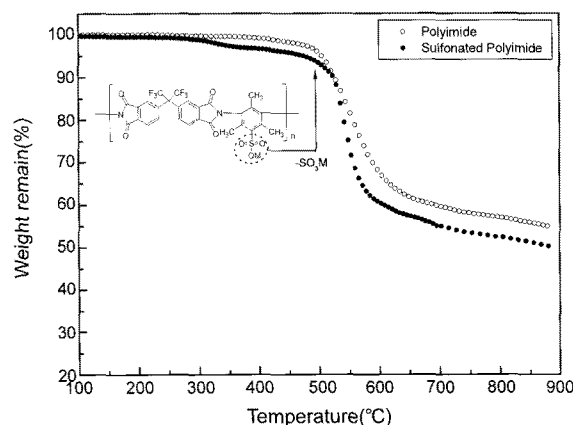

Figure 3. TGA curves of metal ion-exchanged, sulfonated 6FDA-based polyimide.

well known gas transport properties of polymers,^{27,28} which is polymers show the trade-off relation such as polymers with high permeabilities show the low selectivities. Generally, the permeability (P) is depended on the diffusivity (D) and solubility (S). As listed in Table 1, Sample SPI showed lower diffusivities and solubilities for all of the gases (CO_2 , O_2 and N_2) than those of sample PI. That is, the gas transport properties of sample SPI were reasonably explained the decreased permeabilities compared with sample PI.

Figure 4 shows the permeabilities of metal ions exchanged sulfonated polyimides as function of metal ionic radii. The permeabilities of metal ions exchanged sulfonated polyimide membranes were lower than those of SPI membranes due to the incorporation of ionic groups into a polymer chain causes electrostatic crosslinking and decrease in free volume.²⁹ As expected, the CO_2/N_2 and O_2/N_2 selectivities of metal ions

Table 1. Diffusion and Solubility Coefficients of Sulfonated Polyimide Membranes

P^a , D^b and S^c Coefficients	Polyimide samples	
	PI	SPI
$P(\text{CO}_2)$	452.7	360.3
$P(\text{O}_2)$	126.5	95.5
$P(\text{CO}_2)/P(\text{N}_2)$	15.1	20.4
$P(\text{O}_2)/P(\text{N}_2)$	4.2	5.4
$D(\text{CO}_2)$	26.4	24.0
$D(\text{O}_2)$	24.0	20.9
$D(\text{CO}_2)/D(\text{N}_2)$	2.3	2.7
$D(\text{O}_2)/D(\text{N}_2)$	2.1	2.3
$S(\text{CO}_2)$	171.6	149.9
$S(\text{O}_2)$	52.8	45.7
$S(\text{CO}_2)/S(\text{N}_2)$	6.5	7.6
$S(\text{O}_2)/S(\text{N}_2)$	2.0	2.3

^aPermeability coefficients: $1 \text{ Barrer} = 1 \times 10^{-10} \text{ cm}^3(\text{STP})/\text{cm}^2 \cdot \text{s} \cdot \text{cmHg}$.

^bDiffusion coefficients: Unit= $1 \times 10^{-8} \text{ cm}^2/\text{s}$. ^cSolubility coefficients: Unit= $1 \times 10^{-3} \text{ cm}^3(\text{STP})/\text{cm}^3 \cdot \text{cmHg}$.

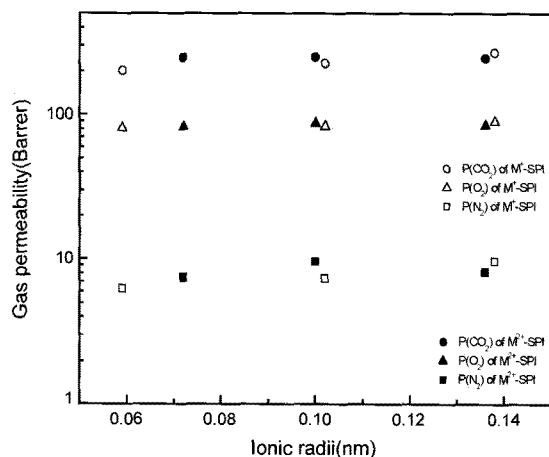

Figure 4. Gas permeabilities of metal ion-exchanged, sulfonated polyimide membranes.

exchanged sulfonated polyimide membranes showed higher than those of sample SPI membranes. These results showed well agreement with our previous researches.^{17,19} Also, the permeabilities of sulfonated polyimide membranes exchanged with the monovalent cations (Li^+ , Na^+ and K^+) increased in the order: Samples $\text{Li-SPI} < \text{Na-SPI} < \text{K-SPI}$. These results well agreed with the ionic radius [Li^+ (0.059 nm), Na^+ (0.102 nm) and K^+ (0.138 nm)]. That is, the larger metal ion exchanged sulfonic acid groups on the phenylene groups inhibit the close packing of the polymer chain. In the case of sulfonated polyimide exchanged with the divalents cations (Mg^{2+} , Ca^{2+} and Ba^{2+}), their permeabilities for all of the gases were followed in the order: Samples $\text{Ca-SPI} > \text{Ba-SPI} > \text{Mg-SPI}$. As compared with SPI exchanged with the monovalent cations, the permeabilities of SPI exchanged with divalents cations were not followed the order of ionic radii [Mg^{2+} (0.072 nm), Ca^{2+} (0.100 nm) and Ba^{2+} (0.136 nm)]. Even though the permeabilities of monovalent cations exchanged SPI membranes well followed the order of ionic size, the permeabilities of divalent cations exchanged SPI membranes are considered with ionic size and electrostatic crosslinking between charged polymers and metal cations. The electron affinities of divalents cations are in the order: $\text{Mg} (-21 \text{ KJ/mol}) > \text{Ba} (-46 \text{ KJ/mol}) > \text{Ca} (-186 \text{ KJ/mol})$ and their ionic radii are in the order: $\text{Ba}^{2+} > \text{Ca}^{2+} > \text{Mg}^{2+}$. As shown in Figure 4, their permeabilities for all of the gases were well followed the electron affinities. That is, the electrostatic crosslinking is more dominant factor than ionic radii to determine the permeation properties of divalent cations exchanged SPI membranes.

Generally, the selectivity of a polymer for component A over component B ($\alpha_{A/B}$) is given by a product of a diffusion selectivity term (D_A/D_B) and a solubility selectivity term (S_A/S_B):

$$\alpha_{A/B} = \frac{P_A}{P_B} = \frac{D_A}{D_B} \times \frac{S_A}{S_B} \quad (2)$$

As listed in Table 2 and 3, the diffusion selectivities ($D_{\text{CO}_2}/D_{\text{N}_2}$ and $D_{\text{O}_2}/D_{\text{N}_2}$) of monovalent cations exchanged SPI membranes decreased with increase of the steric hindrance by the metal cations. On the other hand, the diffusion selectivities of divalent cations exchanged SPI membranes increased in the order: Samples $\text{Mg-SPI} > \text{Ba-SPI} > \text{Ca-SPI}$. Apparently, the selectivities of metal ions exchanged SPI membranes were dominantly determined by the solubility selectivities.

Figure 5 shows the O_2/N_2 and CO_2/N_2 selectivities of metal ions exchanged SPI membranes as function of ionic radii.

Table 2. Diffusion Coefficients and Diffusion Selectivities of Metal Ion-Exchanged, Sulfonated Polyimide Membranes

Samples	Diffusion coefficient (1×10^{-8} cm ² /s)			Diffusion selectivity	
	$D(\text{CO}_2)$	$D(\text{O}_2)$	$D(\text{N}_2)$	$D(\text{CO}_2)/D(\text{N}_2)$	$D(\text{O}_2)/D(\text{N}_2)$
Li-SPI	23.0	18.8	7.6	3.05	2.49
Na-SPI	23.9	19.3	8.9	2.67	2.16
K-SPI	24.0	20.3	11.1	2.16	1.83
Mg-SPI	23.3	19.0	7.9	2.95	2.40
Ca-SPI	23.5	19.7	9.8	2.41	2.02
Ba-SPI	23.5	19.6	8.3	2.82	2.35

Table 3. Solubility Coefficients and Solubility Selectivities of Metal Ion-Exchanged, Sulfonated Polyimide Membranes

Samples	Solubility coefficient (1×10^{-3} cm ³ (STP)/cm ³ · cmHg)			Solubility selectivity	
	$S(\text{CO}_2)$	$S(\text{O}_2)$	$S(\text{N}_2)$	$S(\text{CO}_2)/S(\text{N}_2)$	$S(\text{O}_2)/S(\text{N}_2)$
Li-SPI	87.5	42.9	8.3	10.56	5.18
Na-SPI	94.9	43.3	8.3	11.44	5.22
K-SPI	112.1	44.3	9.8	11.41	4.51
Mg-SPI	106.1	43.4	9.5	11.21	4.59
Ca-SPI	106.6	44.4	9.9	10.81	4.50
Ba-SPI	104.9	43.5	9.8	10.67	4.42

The selectivities of metal ions exchanged SPI membranes decreased with increase of ionic radii with exception case (sample Ba-SPI). For example, when Li^+ (0.059 nm), Na^+ (0.102 nm) and K^+ (0.138 nm) were compared, the O_2/N_2 selectivity of sample Li-SPI (12.90) was higher than those of samples Na-SPI (11.29) and K-SPI (9.24). Exceptionally, when the selectivities of divalent cations exchanged SPI membrane were compared, sample Mg-SPI (11.02) showed higher value than those of samples Ba-SPI (10.36) and Ca-SPI (9.10). As shown in Figure 5, the CO_2/N_2 selectivities of monovalent cation exchanged SPI were increased in the order: Samples Li-SPI (32.17) > Na-SPI (30.59) > K-SPI (27.65), and those of divalent cations exchanged SPI showed the order of sample Mg-SPI (33.08) > sample Ba-SPI (30.05) > sample Ca-SPI (26.06).

Figure 6 shows trade-off between O_2/N_2 selectivity and O_2 permeability. From this figure, one can understand how much the performance of a sulfonated 6FDA-based polyimide membranes were improved when they were properly exchanged with metal cations. The metal cations exchanged SPI membranes showed significant improvement in the O_2/N_2 selectivities with less reduction of the O_2 permeabilities. As can be seen in Figure 6, the selectivities of metal-SPI membranes lie in the upper region of the upper bound line. Possibly it could say that the metal-SPI membranes are commercialized in the future. In this study, the sample K-SPI membranes showed the highest O_2 permeability of 89.98

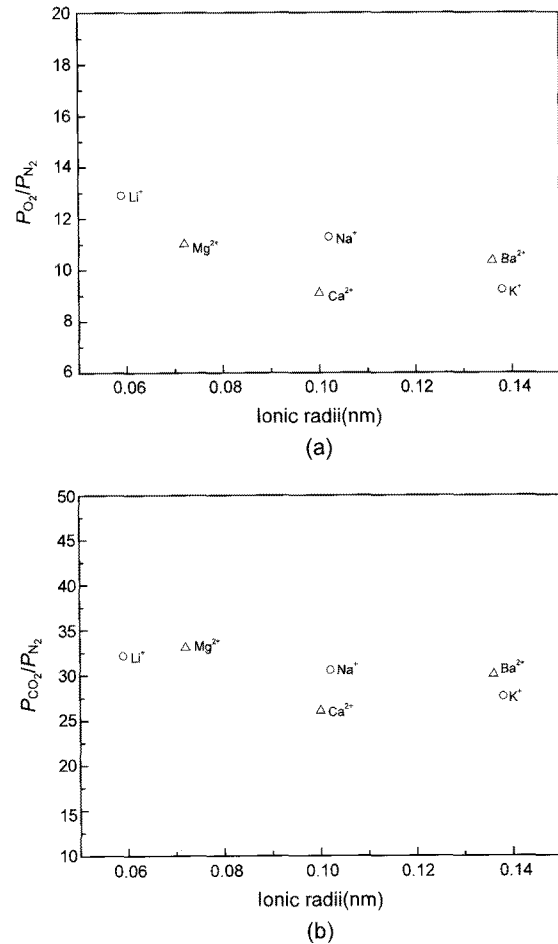
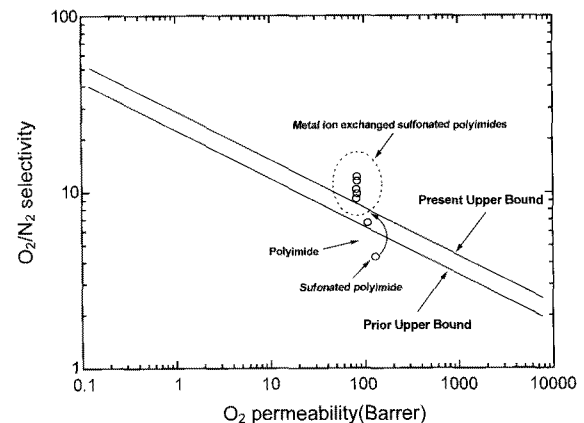
**Figure 5.** Effect of ionic radii of metal cations on (a) O_2/N_2 ; (b) CO_2/N_2 selectivity.**Figure 6.** O_2 permeability versus O_2/N_2 selectivities of metal ion-exchanged, sulfonated, polyimide membranes.

barrer and the sample Li-SPI membranes showed the highest O_2/N_2 selectivity of 12.9, respectively.

Conclusions

The sulfonated, 6FDA-based polyimides were exchanged

the proton of sulfonic acid groups with metal cations using monovalents (Li^+ , Na^+ and K^+) and divalents (Mg^{2+} , Ca^{2+} and Ba^{2+}). The permeabilities and selectivities of metal ions exchanged sulfonated polyimide were determined by the ionic radii and the electrostatic crosslinking. The monovalent cations exchanged SPI membranes showed higher O_2/N_2 selectivities than the divalent cations exchanged SPI membranes. When metal cations with monovalent and divalent cations exchanged to SPI membranes were compared with 6FDA-based polyimide, the metal cations exchanged SPI membranes showed the higher O_2/N_2 and CO_2/N_2 selectivity.

Acknowledgments: Financial support received from dae-deok innopolis is thankfully acknowledged.

References

1. D. R. Paul and Y. P. Yampol'skii, Editors, *Polymeric gas separation membranes*, CRC, Boca Raton, FL, Chapter 10 (1994).
2. M. R. Coleman and W. J. Koros, *J. Membr. Sci.*, **50**, 285 (1990).
3. S. A. Stern, *J. Membr. Sci.*, **94**, 1 (1994).
4. M. Langsam and W. F. Burgoyne, *J. Polym. Sci.*, **31**, 909 (1993).
5. K. Tanaka, Y. Osada, H. Kita, and K. I. Okamoto, *J. Polym. Sci. Part B: Polym. Phys.*, **33**, 1907 (1995).
6. C. Fuhrman, M. Nutt, K. Vichtovonga, and M. R. Coleman, *J. Appl. Polym. Sci.*, **91**, 1174 (2004).
7. R. Wang, S. S. Chan, Y. Liu, and T. S. Chung, *J. Membr. Sci.*, **199**, 191 (2002).
8. T. S. Chung, E. R. Kafchinski, and P. Foley, *J. Membr. Sci.*, **75**, 181 (1992).
9. T. H. Kim, W. J. Koros, G. R. Husk, and K. C. O'Brien, *J. Membr. Sci.*, **37**, 45 (1988).
10. A. Shimazu, T. Miyazaki, T. Matsushita, M. Maeda, and K. Ikeda, *J. Polym. Sci. Part B: Polym. Phys.*, **37**, 2941 (1999).
11. K. Tanaka, H. Kita, M. Okano, and K. Okamoto, *Polymer*, **33**, 585 (1992).
12. S. L. Liu, S. Wang, T. S. Chung, M. L. Chung, Y. Liu, and R. H. Vora, *J. Membr. Sci.*, **202**, 165 (2002).
13. H. Hachisuka, T. Ohara, and K. Ikeda, *J. Membr. Sci.*, **116**, 265 (1996).
14. K. Hiroyoshi, M. Mikawa, and S. Nagaka, *J. Membr. Sci.*, **137**, 241 (1997).
15. W. J. Chen and C. R. Martin, *J. Membr. Sci.*, **95**, 91 (1994).
16. J. S. Chiou and D. R. Paul, *Ind. Eng. Chem. Res.*, **27**, 2161 (1988).
17. J. W. Rhim, G. Chowdhury, and T. Matsuura, *J. Appl. Polym. Sci.*, **76**, 735 (2000).
18. W. J. Koros, G. K. Fleming, S. M. Jordan, T. H. Kim, and H. H. Hoehn, *Prog. Polym. Sci.*, **13**, 339 (1998).
19. H. B. Park, S. Y. Nam, J. W. Rhim, J. M. Lee, S. E. Kim, J. R. Kim, and Y. M. Lee, *J. Appl. Polym. Sci.*, **86**, 2611 (2002).
20. Y. B. Lee, H. B. Park, J. K. Shim, and Y. M. Lee, *J. Appl. Polym. Sci.*, **74**, 965 (1999).
21. R. M. Barrer, *Trans. Faraday Soc.*, **35**, 628 (1939).
22. F. Wang, T. Chen, and J. Xu, *Macromol. Rapid Commun.*, **19**, 135 (1998).
23. Y. K. Kim, H. B. Park, and Y. M. Lee, *J. Membr. Sci.*, **226**, 145 (2003).
24. B. Kruczek and T. Matsuura, *J. Membr. Sci.*, **167**, 203 (2000).
25. G. Ozcayir, G. Goetz, and B. Bikson, European Patent 0811421 (1997).
26. F. Piroux, E. Espuche, R. Mercier, M. Pineri, and G. Gebel, *J. Membr. Sci.*, **209**, 241 (2002).
27. L. M. Robeson, *J. Membr. Sci.*, **320**, 390 (2008).
28. R. D. Freeman, *Macromolecules*, **32**, 375 (1999).
29. V. D. Matterna and W. M. Risen, *J. Polym. Sci. Part B: Polym. Phys.*, **24**, 753 (1986).