

H-Bridge VSC with a T-Connected Transformer for a 3-Phase 4-Wire Voltage and Frequency Controller of an Isolated Asynchronous Generator

Gaurav Kumar Kasal[†] and Bhim Singh^{*}

[†]Delta Energy System, India

^{*}Dept. of Electrical Engineering Indian Institute of Technology Delhi, India

ABSTRACT

This paper deals with a novel solid state controller (NSSC) for an isolated asynchronous generator (IAG) feeding 3-phase 4-wire loads driven by constant power prime movers, such as uncontrolled pico hydro turbines. AC capacitor banks are used to meet the reactive power requirement of the asynchronous generator. The proposed NSSC is realized using a set of IGBTs (Insulated gate bipolar junction transistors) based current controlled 2-leg voltage source converters (CC-VSC) and a DC chopper at its DC bus, which keeps the generated voltage and frequency constant in spite of changes in consumer loads. The neutral point of the load is created using a T-configuration of the transformers. The IAG system is modeled in MATLAB along with Simulink and PSB (power system block set) toolboxes. The simulated results are presented to demonstrate the capability of the isolated generating system consisting of NSSC and IAG driven by uncontrolled pico hydro turbine and feeding 3-phase 4-wire loads.

Keywords: Stand-Alone Power Generation, Two Leg Voltage Source Converter, Mid Point Capacitor, Voltage and Frequency Control, T- Connected Transformer

1. Introduction

The soaring rates of fossil-fuels and their depletion over the last two decades combined with growing concern over pollution of the environment have led to a boost for renewable energy generation. This accelerated drive has led to tremendous progress in the field of renewable energy systems during the last few decades. It has also resulted in a gradual tapping of the vast mini, micro and

pico hydro and wind energy potential available in isolated locations (where grid supply is not accessible)^[1-4]. In most of the cases these generating units have to operate at a remote unattended site, therefore a maintenance-free system is desirable. In view of this, isolated asynchronous generators (IAG) are gaining momentum for such applications due to low cost, small size, light weight, brushless construction, and self short circuit protection etc compared to other electric generators. However, poor voltage and frequency regulation has been the main hurdle in their applications. In view of this, different voltage and frequency controllers (VFCs) are reported in the literature^[5-13]. Most of these controllers are developed for feeding

Manuscript received August 29, 2008; revised Oct. 25, 2008

[†]Corresponding Author: gauravkasal@gmail.com

Tel: +91-11-26581045, +91-9899496868, IIT Delhi, India

^{*}Dept. of Electrical Engineering, IIT Delhi, New Delhi, India

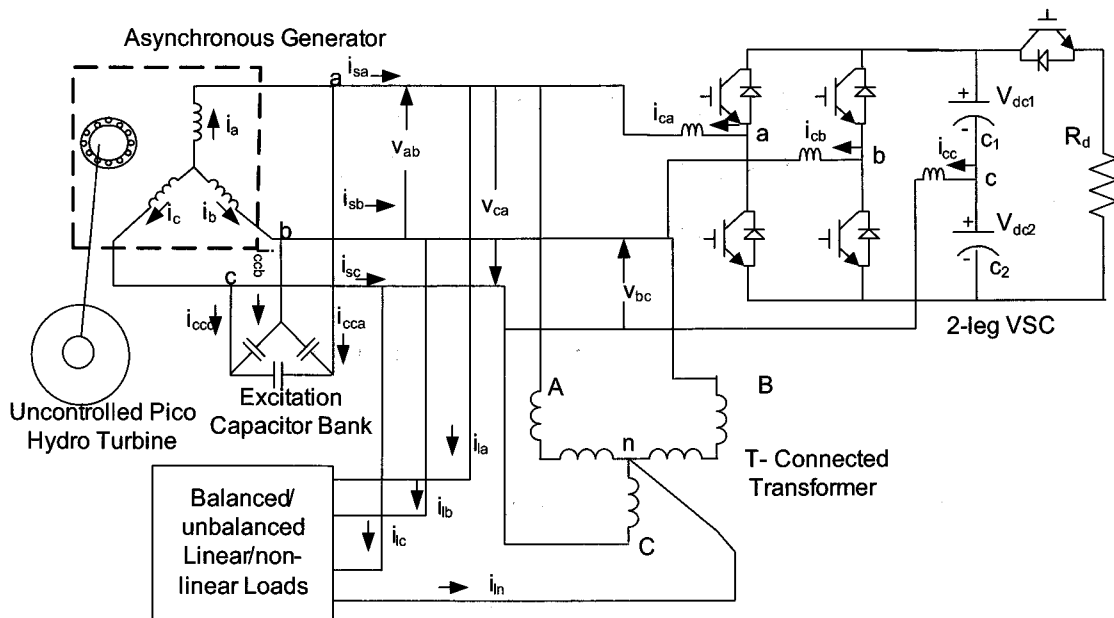

Fig. 1 Schematic diagram of a proposed system configuration

3-phase 3-wire^[5-10] and single phase loads^[11] employing IAG with VFC, and attempts on 3-phase 4-wire application are very rare^[12, 13]. Therefore, an investigation is made with novel configuration of VFC with a T-connected transformer^[14] for neutral current circulation to control the voltage and frequency of the IAG system. The T-connected transformer consists of only two single phase transformers and the currents in three phases of the generator are balanced and sinusoidal. Hence it is regarded as open-circuit for the positive and negative sequence currents.

2. System Configuration

Fig 1 shows an isolated generating system along with the proposed voltage and frequency controller. The proposed system consists of an asynchronous generator driven by uncontrolled pico hydro turbine and its controller is connected at the point of common coupling. Two leg of the VSC are connected to the two phases while the third phase is connected at the mid point of the DC bus capacitors of the VSC. A T-connected transformer is used to create a neutral conductor to form the four wire topology. The transformer acts as a path for zero-sequence components of load currents while two leg VSC serves the

purpose of harmonic elimination, load balancing, and reactive power compensation for the voltage control of the IAG system.

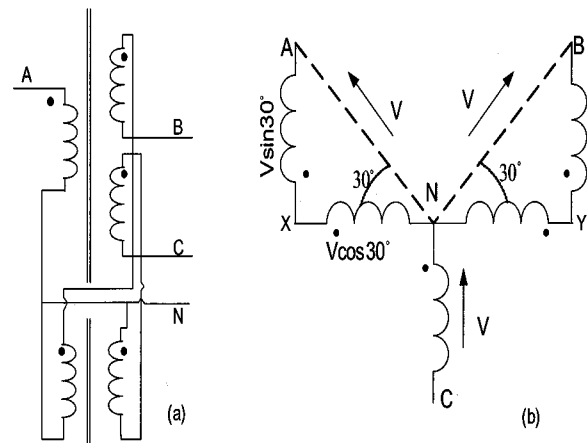

Fig. 2 (a) winding diagram of the proposed T- configuration of the transformer.(b) Phasor diagram of the proposed T- Connected transformer

3. T- Connected Transformer

The T- Connected transformer is a special configuration of two single phase transformers as shown in Figs 2(a) and

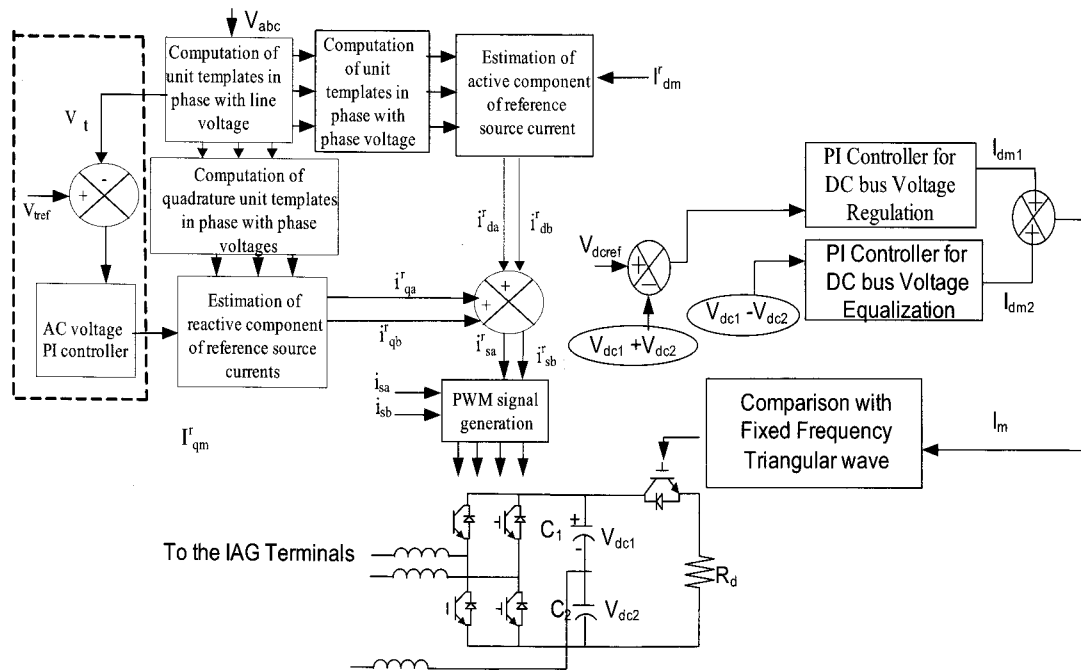

Fig. 3 Control scheme of the proposed controller

(b). Out of two transformers one transformer is a simple single phase transformer, while the other is a tertiary winding. Fig 2(a) shows the winding diagram of the proposed transformer configuration while Fig 2(b) demonstrates its phasor diagram so that voltage and turn ratio of each winding can be estimated. The T-connected transformer provides the path of flow of zero sequence current components.

If one considers voltage across each neutral phase is 'V' volts then voltage across both sides of T configuration is:

$$V_{NY} = V_{NX} = v \cos 30^\circ = 0.866V$$

$$V_{BX} = V_{AX} = v \sin 30^\circ = 0.5V$$

Therefore the turn ratio of all five windings can be represented as 1:0.5:0.5:0.877:0.877.

4. Control Strategy

Fig. 3 shows the control strategy of the proposed controller of the IAG system. The control scheme of the two leg voltage and frequency controller is realized through derivation of reference source currents (i_{sa}^r , i_{sb}^r). Reference source currents consist of two components; one is in the phase or active power component (i_{da}^r , i_{db}^r) for

maintaining constant power at the generator terminals while the other component of the reference source current is in the quadrature or reactive power component (i_{qa}^r , i_{qb}^r) for regulating the terminal voltage. For constant power generation, the active power component of source currents is fixed at a rated value, which is the amplitude of in-phase component of source current (I_{dm}^r). The multiplication of I_{dm}^r with in-phase unit amplitude templates (u_{ad} , u_{bd}) yields the in-phase component of instantaneous reference source currents. These (u_{ad} , u_{bd}) templates are sinusoidal functions, which are derived by unit templates of in-phase line voltages (u_{ab} , u_{bc} , u_{ca}). These templates (u_{ab} , u_{bc} , u_{ca}) are derived by dividing the AC voltages v_{ab} , v_{bc} and v_{ca} by their amplitude V_t . To generate the quadrature component of reference source currents, another set of sinusoidal quadrature unity amplitude templates (u_{aq} , u_{bq} , u_{cq}) is obtained from in-phase unit templates (u_{abd} , u_{bcd} , u_{cad}). The multiplication of these components (u_{aq} , u_{bq}) with output of the PI (Proportional-Integral) AC voltage controller (I_{qm}^r) gives the quadrature, or reactive power component of reference source currents. The sum of instantaneous quadrature and in-phase component of source currents is the reference

source currents (i_{sa}^r , i_{sb}^r), and each phase source current is compared with the corresponding reference current to generate the PWM switching signal for VSC of the controller.

The DC chopper of the VFC is controlled by using two PI (proportional-integral) controllers among which, one is used to control the DC link voltage (V_{dc}) while another one is used for equal voltage distribution across the dc bus capacitors (V_{dc1} and V_{dc2}). A sum of output of both PI controllers (I_{dm1}) and (I_{dm2}) is compared with the fixed frequency triangular carrier wave to generate the variable duty ratio switching signals for the IGBT switch of the DC chopper.

5. Control Algorithm

Basic equations of the control scheme of the proposed controller are as follows. The control algorithm is divided in two sections. Section '5.1' presents the control of two leg VSC while section '5.2' presents the control algorithm of the DC chopper.

5.1 Control of Two Leg VSC

Different components of the controller used in the asynchronous generator-system shown in Fig. 1 are modeled as follows. Three line voltages at the generator terminals (v_{ab} , v_{bc} and v_{ca}) are considered sinusoidal and hence their amplitude is computed as

$$V_t = \sqrt{(2/3) (v_{ab}^2 + v_{bc}^2 + v_{ca}^2)} \quad (1)$$

The unit template in phase with v_{ab} , v_{bc} and v_{ca} are derived as

$$u_{ab} = v_{ab}/V_t; u_{bc} = v_{bc}/V_t; u_{ca} = v_{ca}/V_t \quad (2)$$

From these in phase line voltage templates, unit templates in phase with phase voltage can be estimated as:

$$u_{ad} = (\sqrt{3}/2) u_{ab} + \{1/(2\sqrt{3})\} \{(u_{bc} - u_{ca})\} \quad (3)$$

$$u_{bd} = -(\sqrt{3}/2) u_{ab} + \{(1/(2\sqrt{3})\} \{(u_{bc} - u_{ca})\} \quad (4)$$

$$u_{cd} = -(1/\sqrt{3}) \{(u_{bc} - u_{ca})\} \quad (5)$$

and templates in quadrature with phase voltages are

$$u_{aq} = (1/2) u_{ab} - \sqrt{3} (u_{bcd} - u_{ca}) / (2\sqrt{3}) \quad (6)$$

$$u_{bq} = (1/2) u_{ab} + \sqrt{3} (u_{bc} - u_{ca}) / (2\sqrt{3}) \quad (7)$$

$$u_{cq} = -u_{ab} \quad (8)$$

5.1.1 Quadrature Component of Reference Source Currents

The AC voltage error $V_{er(n)}$ at the n^{th} sampling instant is

$$V_{er(n)} = V_{tref(n)} - V_{t(n)} \quad (9)$$

where $V_{tref(n)}$ is the amplitude of reference AC terminal voltage and $V_{t(n)}$ is the amplitude of the sensed three-phase AC voltage at the generator terminals at the n^{th} instant.

The output of the PI controller ($I_{qm(n)}$) for regulating the AC terminal voltage constant at the n^{th} sampling instant is expressed as

$$I_{qm(n)} = I_{qm(n-1)} + K_{pa} \{V_{er(n)} - V_{er(n-1)}\} + K_{ia} V_{er(n)} \quad (10)$$

where K_{pa} and K_{ia} are the proportional and integral gain constants of the proportional integral (PI) controller. $V_{er(n)}$ and $V_{er(n-1)}$ are the voltage errors in n^{th} and $(n-1)^{\text{th}}$ instants and $I_{qm(n-1)}$ is the amplitude of quadrature component of the reference source current at the $(n-1)^{\text{th}}$ instant.

The quadrature components of reference source currents are computed as

$$i_{qa}^r = I_{qm} u_{aq}, \quad i_{qb}^r = I_{qm} u_{bq} \quad (11)$$

5.1.2 In-Phase Component of Reference Source Currents

For the constant power application, IAG should generate constant active power to feed either consumer load or auxiliary load (R_d). For the constant power, in-phase component of the reference source current is set equal to the rated amplitude of the active power component of the current which is calculated as:

$$I_{dm}^r = \sqrt{2} (P_{rated}) / (\sqrt{3} V_{rated}) \quad (12)$$

where P_{rated} and V_{rated} are rated power and rated voltage of IAG.

Then the in-phase components of reference source

currents are computed as

$$i_{da}^r = I_{dm}^r u_{ad}; \quad i_{db}^r = I_{dm}^r u_{bd} \quad (13)$$

5.1.3 Reference Source Currents

The reference source currents are the sum of in-phase and quadrature components of the reference source currents as

$$i_{sa}^r = i_{da}^r + i_{qa}^r \quad (14)$$

$$i_{sb}^r = i_{db}^r + i_{qb}^r \quad (15)$$

5.1.4 PWM Current Controller

The reference currents (i_{sa}^r , i_{sb}^r) are compared with the sensed source currents (i_{sa} , i_{sb}). The ON/OFF switching patterns of the gate drive signals to the IGBTs (Insulated Gate Bipolar junction Transistors) are generated from the PWM current controller. The current errors are computed as:

$$i_{saerr} = i_{sa}^r - i_{sa} \quad (16)$$

$$i_{sberr} = i_{sb}^r - i_{sb} \quad (17)$$

These current error signals are amplified and then compared in the PWM current controller for switching the IGBTs of the two leg VSC.

5.2 Control of DC Chopper

To maintain the DC bus voltage of VSC constant, the DC voltage error $V_{dcer(n)}$ at the n^{th} sampling instant is calculated as error voltage of DC bus voltage

$$V_{dcer1(n)} = V_{dcref(n)} - V_{dc(n)} \quad (18)$$

where $V_{dcref(n)}$ is the reference DC voltage and $V_{dc(n)}$ is the sensed DC link voltage of the controller.

The output of the PI controller for maintaining DC bus voltage of the VSC at the n^{th} sampling instant is expressed as

$$I_{dm1(n)} = I_{dm1(n-1)} + K_{pd1} \{V_{dcer1(n)} - V_{dcer1(n-1)}\} + K_{id1} V_{dcer1(n)} \quad (19)$$

The output of another PI controller for equalization of voltage across both the capacitors (C_1 and C_2). Error signal ($V_{dcer2(n)}$) is optimized as:

$$I_{dm2(n)} = I_{dm2(n-1)} + K_{pd2} \{V_{dcer2(n)} - V_{dcer2(n-1)}\} + K_{id2} V_{dcer2(n)} \quad (20)$$

Total output signal is considered as

$$I_m = I_{dm1(n)} + I_{dm2(n)} \quad (21)$$

This output (I_m) is compared with the fixed frequency triangular carrier wave to generate the switching signal for the IGBT of the DC chopper.

6. MATLAB Based Modeling

The proposed IAG system is modeled and simulated in MATLAB using Simulink and PSB toolboxes. The main system consists of an asynchronous machine with excitation capacitor bank, a T connected transformer and VSC based controller. The modeling of IAGs is carried out using a 22 kW, 415V, 50Hz, Y connected asynchronous machine. The controller is realized with a 2-leg voltage source converter and DC chopper at its DC bus. Both linear and non-linear loads are considered here to demonstrate the capability of the controller. Simulation is carried out in discrete mode at 5e-6 step size with ode23tb (stiff/ TR-BDF-2) solver.

7. Results and Discussion

The voltage and frequency controller for the IAG system feeding the 3-phase 4-wire non-linear, balanced/unbalanced and mixed loads are simulated and waveforms of the generator voltages (v_{abc}) and currents (i_{abc}), capacitor current (i_{cca}), load currents (i_{labc}), controller currents (i_{cabc}), neutral current of load (i_{ln}), terminal voltage (V_t), DC bus voltages (V_{dc} , V_{dc1} and V_{dc2}), frequency (f) and the variation of generator power, consumer load power and auxiliary load power (P_{gen} , P_{load} and P_{dump}) and variation in transformer VA rating (T_{VA}) are shown in Figs. 4-5. For the simulation, a 22 kW, 415V, 4 pole, 50 Hz asynchronous machine has been used as an asynchronous generator and parameters are given in the Appendix.

7.1 Performance of the Isolated System Feeding 3-Phase 4-Wire Linear Loads

Fig 4 demonstrates the performance of the controller for

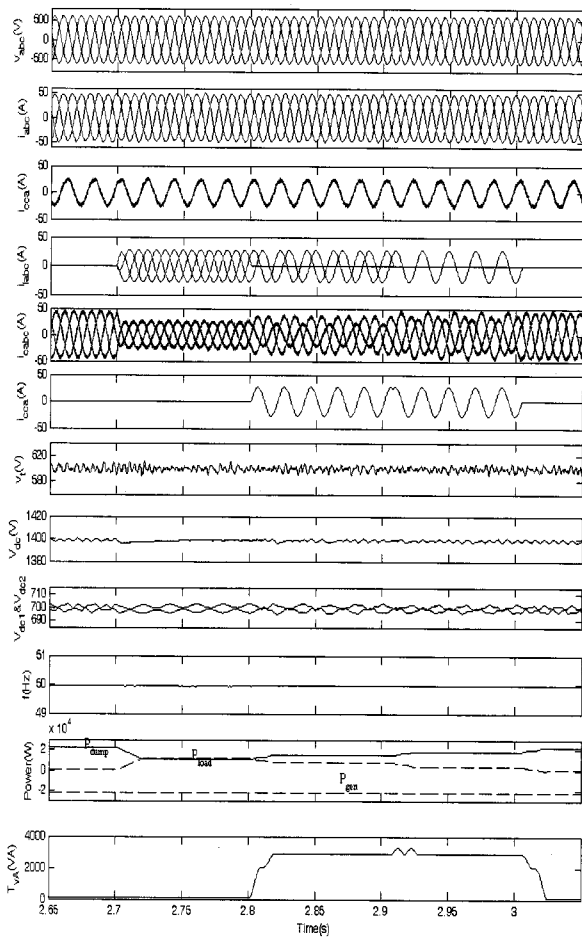

Fig. 4 Performance of the controller under application of balanced/unbalanced linear loads

feeding the 3-phase 4-wire, 0.8 pf lagging reactive load. At 2.7 s three single phases, 0.8 pf lagging reactive loads are applied between each phase and neutral terminal and it is observed that the generator current is momentarily increased however due to action of the controller it is regulated at constant value and it maintains the frequency constant. At 2.8 s one phase and later on at 2.9 s another phase of the load is opened and the load becomes unbalanced. It is observed that the controller maintains constant voltage and frequency. It also functions as a load balancer and generator currents remain balanced and sinusoidal.

7.2 Performance of the Isolated System Feeding 3-Phase 4-Wire Non-linear Loads

Fig. 5 shows the performance of the proposed

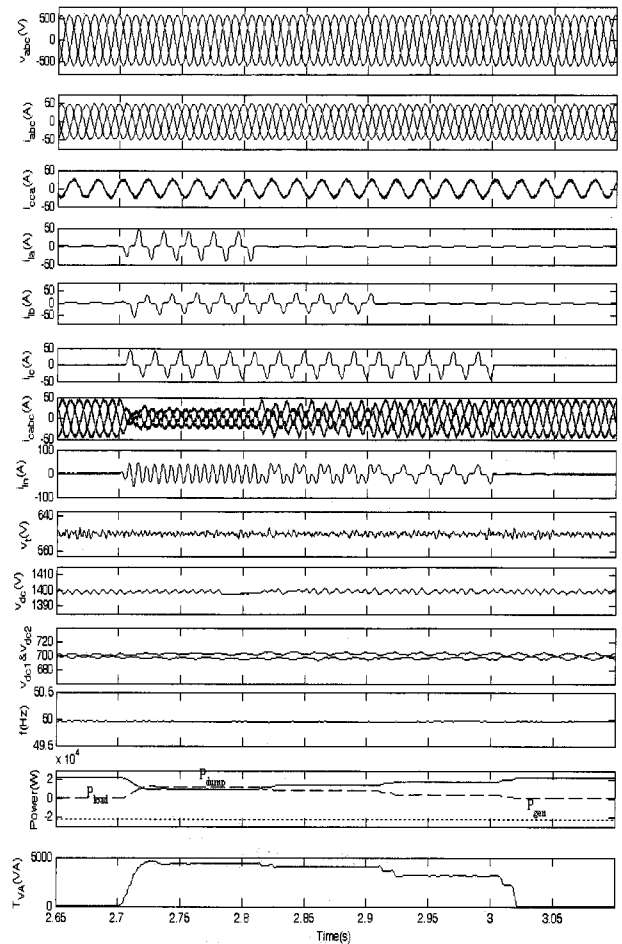

Fig. 5 Performance of the controller under application of balanced/unbalanced non-linear loads.

generating system with 3-phase 4-wire balanced-unbalanced non-linear loads using single phase diode rectifier with resistive load and capacitor filter at its DC bus. At 2.7 sec, a balanced non-linear load is applied and the auxiliary power (P_{dump}) in VFC is reduced for regulating the generated power, and controller currents (i_{cabc}) become non-linear in nature for eliminating harmonic currents. During the unbalanced load, at 2.8 sec and 2.9 sec the DC bus capacitor (v_{dc}) charging and discharging are observed and the load neutral current (i_{in}) flows through the windings of the T connected transformer. In addition, this controller also maintains the equal DC voltages (V_{dc1} and V_{dc2}) across both the mid-point capacitors at DC bus of VFC.

Fig. 6 demonstrates the harmonic spectra of the generator voltage (v_a), generator current (i_a) and the load

current (i_{lc}) under balanced load conditions. It is observed from these figures that total harmonic distortion (THD) of the terminal voltage and the generator current is less than 5%, the limit imposed by IEEE – 519 standards [15]. Therefore it demonstrates that this controller also functions as a harmonic eliminator.

8. Conclusion

A novel reduced switch configuration of voltage and frequency controller for an isolated asynchronous generator driven by an uncontrolled pico hydro turbine has been used for feeding 3-phase 4-wire loads. The size, cost and complexity of the controller have been comparatively reduced more than other 3-phase 4-wire topology of the voltage and frequency controllers in a stand alone power generating system. The obtained results have demonstrated the capability of the controller as a harmonic eliminator, a load balancer along with voltage and frequency regulator in such stand-alone power generating systems. The proposed T-connected transformer has provided the path for the load neutral current and has facilitated the generating system to feed three-phase as well as single phase consumer loads. The performance of the controller has been found quite satisfactory under different dynamic conditions.

Appendices

- A. The parameters of 22kW, 415V, 50Hz, Y-connected, 4-pole asynchronous machine are given below.

$$R_s = 0.2511\Omega, R_r = 0.2489\Omega, X_{lr} = X_{ls} = 0.52\Omega, J_g = 0.304 \text{ kg-m}^2, C = 12 \text{ kVAR}$$

$$L_m = 0.075 \quad I_m < 8.0$$

$$L_m = 0.075 - 0.003(I_m - 8.0) \quad 8 < I_m < 13$$

$$L_m = 0.06 - 0.002(I_m - 13) \quad 13 < I_m < 23$$

$$L_m = 0.041 \quad I_m > 23$$

- B. Controller Parameters

$$C_1 = C_2 = 20\text{mF}, R_f = .1\Omega \text{ and } L_f = 3\text{mH}$$

$$\text{AC Voltage PI Controller: } K_{pa} = 0.023, K_{ia} = 0.012$$

$$\text{DC Voltage PI Controller: } K_{pd1} = 1.3, K_{id1} = 6.$$

$$\text{DC Voltage Equalization PI Controller: } K_{pd2} = 0.18, K_{id2} = 0.012.$$

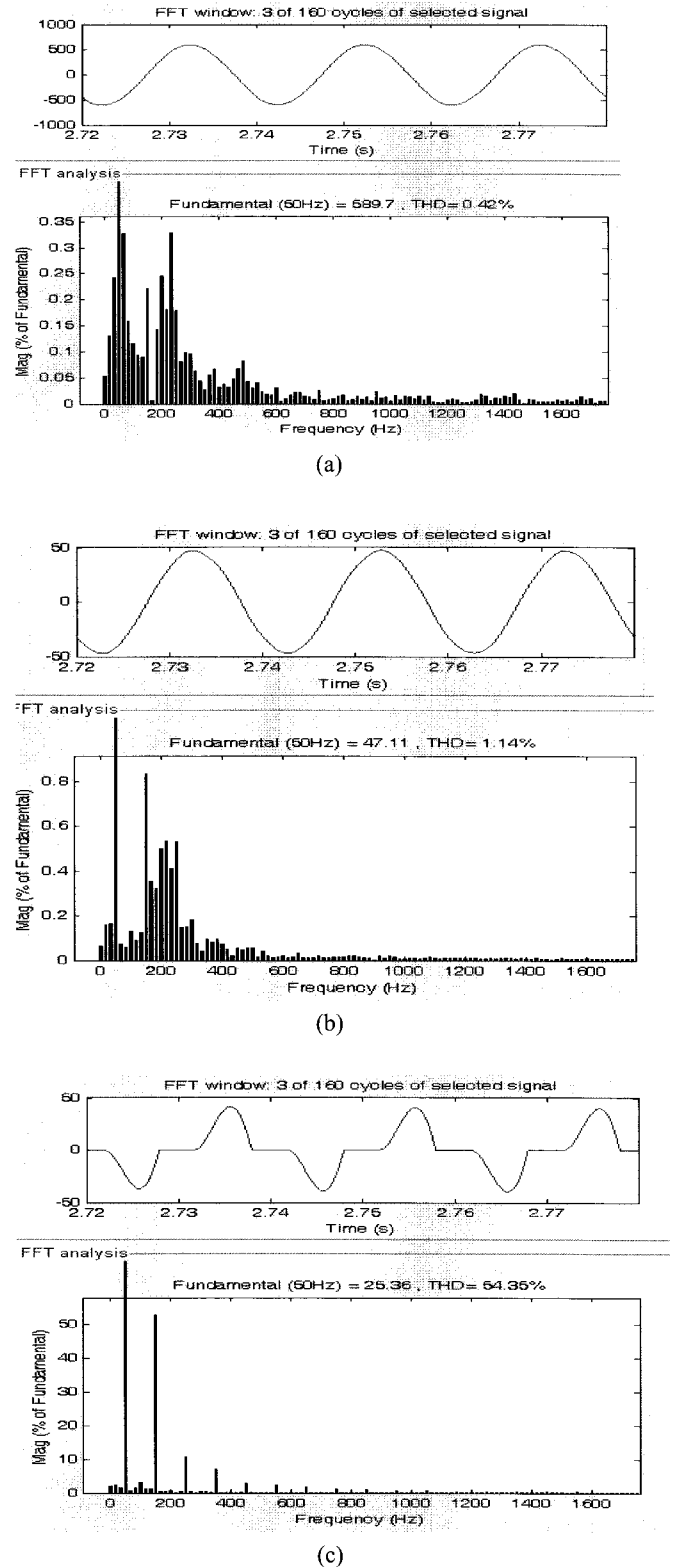

Fig. 6 Waveforms and harmonic spectra of generator voltage (v_a), generator current (i_a) and consumer load current (i_{lc}) feeding balanced non-linear load

References

- [1] L.L. Lai and T.F. Chan, "Distributed Generation -Induction and Permanent Magnet Generators", *John Wiley and Sons Ltd, Chichester, UK*, 2007.
- [2] M. Godoy Simoes and Felix A. Farret, "Alternative Energy Systems", *CRC Press Florida*, 2008.
- [3] Ion Boldea, "Variable Speed Generators", *CRC Press, Florida* 2006.
- [4] R.C. Bansal, "Three phase self excited induction generators: an overview", *IEEE Trans. on Energy Conversion*, Vol 20, No. 2, pp. 292-299, June 2005.
- [5] E. Suarez and G. Bortolotto, "Voltage – frequency control of a self excited induction generator", *IEEE Trans Energy Convers*, Vol. 14, No. 3 pp.394-401, Sept. 1999.
- [6] T.F. Chan, K.A. Nigim and L.L.Lai, "Voltage and frequency control of self excited slip ring induction generators", *IEEE Trans. on Energy Conversion*, Vol. 19, No. 1, pp. 81-87, March 2004.
- [7] B. Singh, S.S. Murthy and S. Gupta, "Analysis and implementation of an electronic load controller for a self-excited induction generator", *IEE Proceedings - Generation Transmission and Distribution*, Vol 151, No.1, pp. 51-60, Jan. 2004.
- [8] R. Bonert and S. Rajakaruna, "Self-excited induction generator with excellent voltage and frequency control", *IEE Proc.-Gener. Transm. Distrib.*, Vol. 145, No. 1, pp. 33-39, January 1998.
- [9] I. Tamrakar, L. B. Shilpkar, B. G. Fernandes and R. Nilsen, "Voltage and frequency control of parallel operated synchronous generator and induction generator with STATCOM in micro hydro scheme", *Proc IET – Gener. Transm. Distrib.*, Vol.1, No. 5, pp 743-750, Sept. 2007.
- [10] J.M. Ramirez, Emmanuel. and M Torres, "An Electronic Load Controller for the Self-Excited Induction Generator", *IEEE Transactions on Energy Conversion*, Vol. 22, No. 2, pp 546 – 548, June 2007.
- [11] B. Singh, S.S. Murthy and S. Gupta, "An electronic voltage and frequency controller for single-phase self-excited induction generators for pico hydro applications", in *Proc of IEEE Sixth International Conf. on Power Electronics and Drive Systems (PEDS' 05)*, pp 240-245, 2005.
- [12] Gaurav Kumar Kasal and Bhim Singh, "Decoupled voltage and frequency controller for isolated asynchronous generator supplying 3-phase 4-wire loads", *IEEE Trans. on Power Delivery*, Vol.23, No.2, pp. 966-973, April 2008.
- [13] J. A. Barrado, R. Grino and Hugo Valderrama, "Standalone Self-Excited Induction Generator with a Three-Phase Four-Wire Active Filter and Energy Storage System," in *Proc. of IEEE International Symposium on Industrial Electronics (ISIE'07)*, Vigo, Spain, pp. 600-605, June 2-5, 2007.
- [14] Bhim Singh, Vipin Garg, and G. Bhuvaneswari, "A novel T-connected autotransformer-based 18-pulse AC–DC converter for harmonic mitigation in adjustable-speed induction-motor drives", *IEEE Transactions on Industrial Electronics*, Vol. 54, No.5, pp. 2500-2511, Oct. 2007.
- [15] IEEE Guide for Harmonic Control and Reactive Compensation of Static Power Converters, *IEEE Standard* 519–1992.



Gaurav Kumar Kasal was born in Bhopal, India, in Nov, 1978. He received the B.E (Electrical) and M.Tech. degree from the National Institute of Technology (NIT) Allahabad and National Institute of Technology (NIT) Bhopal, India respectively in 2002 and 2004. Since Dec 2004, he has been pursuing the Ph. D. degree with the Department of Electrical Engineering, Indian Institute of Technology (IIT) Delhi, New Delhi, India and has published 35 international research papers in journals and conferences. He is working as a Sr. engineer in the R&D department of Delta energy system (India). His field of interest includes power electronics and drives, switching power supply, renewable energy generation and applications.



Bhim Singh (SM'99) was born in Rahamapur, India, in 1956. He received his B.E (Electrical) degree from the University of Roorkee, Roorkee, India, in 1977 and his M.Tech and Ph.D. degree from the Indian Institute of Technology (IIT) Delhi, New Delhi, India in 1979 and 1983, respectively. In 1983, he joined the Department of Electrical Engineering, University of Roorkee, as a lecturer, and in 1988 became a Reader. In December 1990, he joined the Department of Electrical Engineering, IIT Delhi, as an Assistant Professor. He became an Associate Professor in 1994 and Professor in 1997. His areas of interest include power electronics, electrical machines and drives, active filters, FACTS, HVDC and power quality. Dr. Singh is a fellow of Indian National Academy of Engineering (INAE), the Institution of Engineers (India) (IE (I)), and the Institution of Electronics and Telecommunication Engineers (IETE), a life member of the Indian Society for Technical Education (ISTE), the System Society of India (SSI), and the National Institution of Quality and Reliability (NIQR) and Senior Member of Institute of Electrical and Electronics Engineers (IEEE).