

## Articles

### Mulberry Paper Bag $\mu$ -Solid Phase Extraction for the Analysis of Five Spice Flavors by Gas Chromatography-Mass Spectrometry

Ok-Kyung Yoon and Dong-Sun Lee\*

Department of Chemistry, Seoul Women's University, Seoul 139-774, Korea. \*E-mail: dslee@swu.ac.kr

Received July 26, 2008, Accepted December 15, 2008

Headspace micro solid phase extraction using mulberry paper bag (HS-MPB- $\mu$ -SPE) has been developed and validated for the analysis of volatile flavor compounds from five spice by gas chromatography-mass spectrometry (GC/MS). HS-MPB- $\mu$ -SPE was performed with adsorbent particles enclosed inside a mulberry paper bag. Four different kinds of adsorbents such as Tenax TA, Porapak Q, dimethylpolysiloxane and polyethylene glycol were tested. The extraction solvents compared were petroleum ether, methylene chloride, and chloroform. Better results were obtained when Tenax TA and petroleum ether were used. The limit of detection (LOD) and the limit of quantitation (LOQ) were in the range of 1.3 ng/mL and 4.3 ng/mL, respectively, for *o*-cymene as a model compound of monoterpene. Proposed method showed good reproducibility (3.3%, RSD) and good recoveries (94.0%). The HS-MPB- $\mu$ -SPE is very simple to use, inexpensive, rapid, requires small sample amounts and solvent consumption. Because the solvent for extraction is reduced to only a very small volume (0.6 mL), there is minimal waste or exposure to toxic organic solvent and no further concentration step. This method allows successful characterization of the headspace in contact with the five spice sample. Strong *trans*-anethole from star anise or fennel is a characteristic flavor of five spice powders. HS-MPB- $\mu$ -SPE combined with GC/MS can be a promising technique for the broad spectrum measurement of volatile aroma compounds from solid spices.

**Key Words:** Mulberry paper bag, Micro solid phase extraction, GC/MS, Flavor, Five spice powders

#### Introduction

Sample preparation process is a very important and necessary step but it is time consuming, labor intensive, and error prone steps in analysis of flavor. It may include extracting analytes from a complex matrix, removing interferences, preconcentrating very dilute analytes to get a concentration high enough to measure, or transforming analyte into easily detected form.

Separation of volatile aroma compounds from botanical samples is most often achieved by several conventional sample preparation methods such as steam distillation, solvent extraction, enfleurage, maceration, cold pressing, supercritical extraction, purge and trap, and solid phase extraction (SPE) prior to gas chromatography-mass spectrometry (GC/MS).<sup>1-5</sup> Both steam distillation and solvent extraction are liable to produce artifacts by isolating non-volatile materials from tissue or by partial decomposition. Solvent extraction, enfleurage, and maceration are very time consuming and labor intensive. SPE is mainly used to isolate and preconcentrate selected analytes from a liquid, fluid, gas or even solid by their sorption and transfer to solid phase. After physical separation of the adsorbent and sample medium the analytes are recovered by liquid or fluid elution, or by thermal desorption. SPE was generally performed with short columns, cartridges, or discs and it avoids or minimizes the disadvantages of liquid-liquid extraction that require the use of large quantities of organic solvents. Methods involving application of SPE directly to the spice sample to isolate flavor compounds are found very occasionally in the recent references.

Other recent approaches in sample preparation have been directed towards high performance miniaturization, which is fast, simple, and inexpensive, requires minimum solvent and produces little waste. For example, the solid phase microextraction (SPME) or the liquid phase microextraction (LPME) are studied in many areas of application.<sup>1,2,5-13</sup> Alternatively, the headspace solid-phase trapping solvent extraction (HS-SPTE) and GC/MS were also studied previously in our lab for the determination of flavors and fragrances in rose flowers, lavender, thyme, chestnut blossom, garlic, as well as citrus fruits.<sup>1,6,7,14-17</sup>

The main purpose of the present study was to develop a novel, simple, rapid, sensitive, reproducible, and low cost method that are applicable for extracting and measuring flavor compounds from the five spice samples. The five spice powders consist a pungent mixture of five ground or crushed powders among amomum (*Amomum villosum*, Zingiberaceae, Shanren by Chinese) fruit, galangal (*Kaempferia galangal*, Zingiberaceae, Shanai by Chinese) or zinger (*Zingiber officinale*, Zingiberaceae) rhizome, cinnamon (*Cinnamomum verum*, Lauraceae) barks, star anise (*Illicium verum*, Illiciaceae) seed-bearing follicles, fennel (*Foeniculum vulgare*, Apiaceae) seeds, clove (*Syzygium aromaticum*, Myrtaceae) buds, Sichuan pepper (*Zanthoxylum piperitum*, Rutaceae, Huajiao by Chinese), or licorice (*Glycyrrhiza glabra*, Fabaceae). In this study, a sample preparation technique based on micro solid phase extraction ( $\mu$ -SPE) using a Korean traditional hand made mulberry paper bag (MPB) has been developed as a versatile sample preparation device designed for the rapid and simple analysis of flavor

compounds. Analytical performance was validated by comparison with the HS-SPME after optimization of the experimental parameters. Headspace mulberry paper bag micro solid phase extraction (HS-MPB- $\mu$ -SPE) using Tenax TA prior to GC/MS analysis allowed successful determinations of flavor compounds from five spice powders (wūxiāngfēn by Chinese).

## Experimental

**Materials and reagents.** The dried samples of amomum fruit, galangal rhizomes, cinnamon barks, star anise harvested in Guang-Xi, and fennel seeds were purchased from the local market of Chongqing, dried clove buds and Sichuan pepper from Wuhan in China. Five spice powders were obtained from Chongqing. Recipes for the five spice powders are quite different depending on the locality. Five spice powders from Chongqing consist powdered star anise, fennel seeds, galangal rhizomes, cinnamon barks, and amomum fruits. Vecjia Wuxiangfen (Shanghai Haoweijia Food Co., Ltd.) is a pungent mixture of ground or crushed powders of cinnamon, star anise, Sichuan pepper, fennel, and licorice. Hong-Xing-Yuan Wuxiangfen (Shanghai) is mixed powders of Sichuan pepper, star anise, cinnamon, Dahurian Angelica root (*Radix Angelicae dahuricae*), and clove buds. Bart Chinese five spice (Bristol, England) is mixed powders of cinnamon, fennel, star anise, ginger, and clove buds.

All reference standards were of analytical grade and were purchased from Sigma-Aldrich (St. Louis, MO, USA) and Tokyo Kasei (Nihonbashi, Tokyo, Japan). Methanol, petroleum ether and methylene chloride of chromatographic grade were obtained from Mallinckrodt Baker (Phillisburg, NJ, USA) and chloroform (chromatographic grade) from EM Science (Gibbstown, NJ, USA).

2,6-Diphenylene-oxide 2,6-diphenyl-p-phenylene oxide polymer (Tenax TA, particle size 250 ~ 177  $\mu\text{m}$  60/80 mesh) adsorbent was purchased from Supelco (Bellefonte, PA, USA). Ethylvinylbenzene divinyl benzene copolymer (Porapak Q, 197-177  $\mu\text{m}$  50/80 mesh) was obtained from Waters (Milford, MA, USA), dimethylpolysiloxane (3% OV-1/Chrom W-HP, 149-125  $\mu\text{m}$ , 100/120 mesh) and polyethylene glycol (3% CWAX 20M Chrom W-HP, 177-149  $\mu\text{m}$ , 80/100 mesh) from Chromatography Research Supplies, Inc. (Fairbank Addison, IL, USA).

**Headspace mulberry paper bag-micro solid phase extraction (HS-MPB- $\mu$ -SPE).** Schematic illustration for the design of prototype MPB is shown in Fig. 1. Prior to use, adsorbent particles were pre-rinsed with petroleum ether and dried at 150  $^{\circ}\text{C}$  for 60 min in order to remove impurities. Purified adsorbent (*ca.* 100 mg) was obtained on a small sheet of mulberry paper (10.5 cm, length 4.5 cm, width) bound three folding-parts with transverse rectangular shape. The both edges were folded obliquely so that the adsorbent was enclosed in a mulberry paper. Then, one side edge was bent again obliquely. And then, a bending part was inserted into across a folded mulberry paper. Finally, a small label was

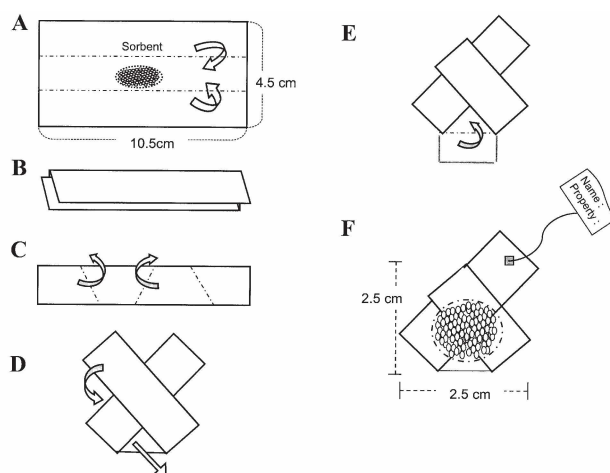

- Adsorbent (about 100 mg) is placed on a small sheet of mulberry paper (10.5 cm, length 4.5 cm, width).
- Then, a mulberry paper is folded twice upward and downward along folding lines so that one part covers another part. The adsorbent particles are enclosed within three pieces of mulberry paper.
- The both edges were folded obliquely so that adsorbent is placed in side a mulberry paper.
- One side edge was bent again obliquely.
- A bending part was inserted into across a folded mulberry paper.
- A label is attached to a pentagonal bag of mulberry paper.

**Figure 1.** Schematic illustration showing how to fold a prototype mulberry paper bag for  $\mu$ -solid phase extraction.

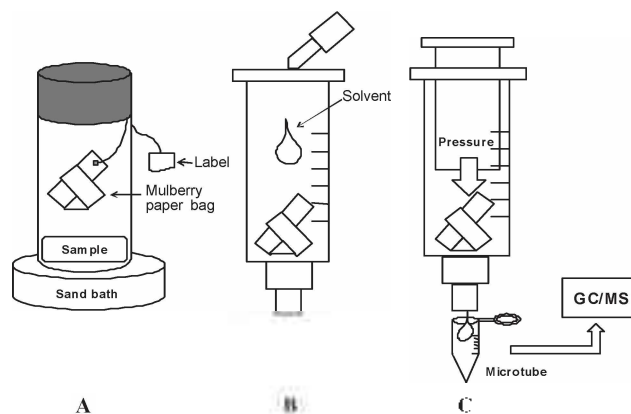

- Extraction step for headspace  $\mu$ -SPE after sample loading
- Elution step using  $\mu$ -solvent (about 0.6 mL)
- In syringe extraction by plunger pressure prior to GC/MS.

**Figure 2.** Schematic drawing of headspace  $\mu$ -solid phase extraction procedure using a mulberry paper bag.

attached to a small pentagonal-shaped bag (*ca.* 2.5 cm, I.D. 2 mm, thickness) of mulberry paper.

HS-MPB- $\mu$ -SPE procedure for GC/MS is illustrated in Fig. 2. In the extraction step for HS-MPB- $\mu$ -SPE, flavor compounds emitted from spice samples (*ca.* 1 g) obtained in a vial (30 mL) sealed hermetically were extracted by exposure of a small MPB to the headspace for 60 min at 40  $^{\circ}\text{C}$ . After adsorption, a MPB was removed from a sample vial and inserted immediately into a clean syringe barrel (10 mL, 1.5 cm I.D. 9 cm long), and then the flavor compounds collected in a MPB were eluted by extraction with 0.6 mL of petroleum ether or other solvent with the plunger pressure of reciprocating movement. Aliquots were analyzed by GC/MS without further treatment

after the desorption step.

**Headspace solid phase microextraction (HS-SPME).** All SPME holders and coating fibers were obtained from Supelco (Bellefonte, PA, USA). For HS-SPME sampling, the 50/30m divinylbenzene/carboxen/polydimethylsiloxane (DVB/CAR/PDMS, gray) fiber was used by evaluation of relative efficiency<sup>6,8</sup> with the 100m polydimethylsiloxane (PDMS, red) and 75m carboxen/polydimethyl-siloxane (CAR/PDMS, black) fibers. Prior to use, SPME fiber was conditioned in the hot GC injection port at 250 °C for 60 min in order to remove contaminants and blank run must be performed to confirm the absence of contamination peaks.

About 1 g of the spice samples was placed in a 50 mL vial and the vial was capped with a mini-nut cap. The vial was left to equilibrate for at least 30 min at 40 °C before HS-SPME. Unless otherwise stated, the SPME fiber was exposed to the headspace in contact with the sample and not the sample matrix itself for 30 min at 40 °C. After adsorption, the SPME fiber was removed from the sample vial and immediately inserted into the injection port of the GC/MS system where the thermal desorption was performed at 240 °C for 1 min.

**Gas chromatography-mass spectrometry (GC/MS).** Chromatographic separations were performed on a fused silica cross-linked 6% cyanopropylphenyl-94%-dimethylsiloxane copolymer (DB-624, 30 m length 0.25 mm I.D. 1.4  $\mu$ m film thickness, J & W Scientific, Folsom, CA, USA) capillary column. Flow rate of carrier gas (He, 99.9995%) was 1.0 mL/min. GC/MS analyses were carried out by a Trace GC 2000 and a GC-Q plus ion trap MS<sup>9</sup> (Thermoquest-Finnigan, Austin, TX, USA) in the electron impact (EI) ionization mode. The injector temperature was 240 °C. A split injection with a ratio of 1:30 was used. The injected sample volume was 1  $\mu$ L. The oven temperature program was 50 °C (3 min)-5 °C/min-220 °C (10 min). Transfer line temperature was 230 °C. The ion trap mass spectrometer was operated as follows ionization voltage, 70 eV; ion source temperature, 200 °C. The measuring mode was scanned from 50 to 500 mass ranges. The identity of volatile compounds was assigned by comparison of the

obtained mass spectra of relevant chromatographic peaks with those of authentic standards and with corresponding spectra of the NIST and Wiley libraries.

## Results and Discussion

### Optimization of headspace mulberry paper bag-micro solid phase extraction (HS-MPB- $\mu$ -SPE).

**Selection of adsorbent:** Fig. 3 shows microscopic images of adsorbents used in this study and observed by microscopes (Nikon eclipse TS100 for 200X magnification and Zeiss Stemi 2000 for 50X magnification). The shape of Porapak Q particles was spherical. Tenax TA, CWAX, and OV-1 were granular and available in a wide range of mesh sizes. Tenax TA is one of the hydrophobic commercial adsorbents and a macroporous, semi-crystalline polymer manufactured from 2,6-diphenyl-*p*-phenylene oxide (DPPO).

A series of HS-MPB- $\mu$ -SPE experiments according to the procedure described in experimental section were carried out to compare the relative extraction efficiencies of different adsorbents. Extraction efficiency was confirmed by the comparison of the peak area corresponding to 10  $\mu$ L of the working standard solution of *o*-cymene (0.1 mg/mL methanolic solution)

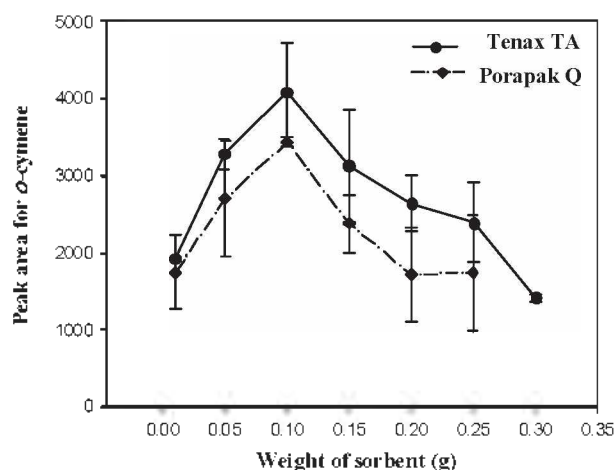

Figure 4. Effect of adsorbent weight for HS-MPB- $\mu$ -SPE and GC/MS.

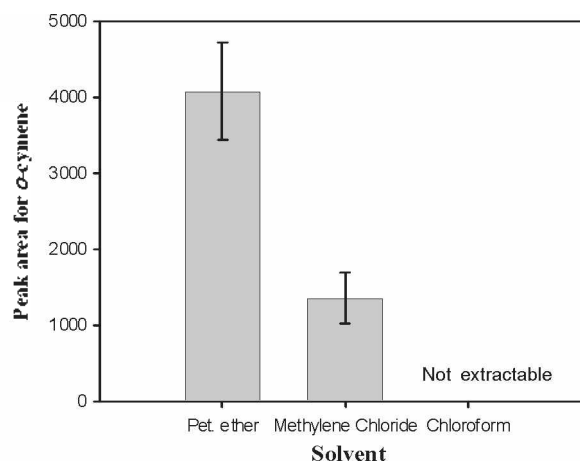

Figure 5. Comparison of sensitivities by different solvents for HS-MPB- $\mu$ -SPE and GC/MS.

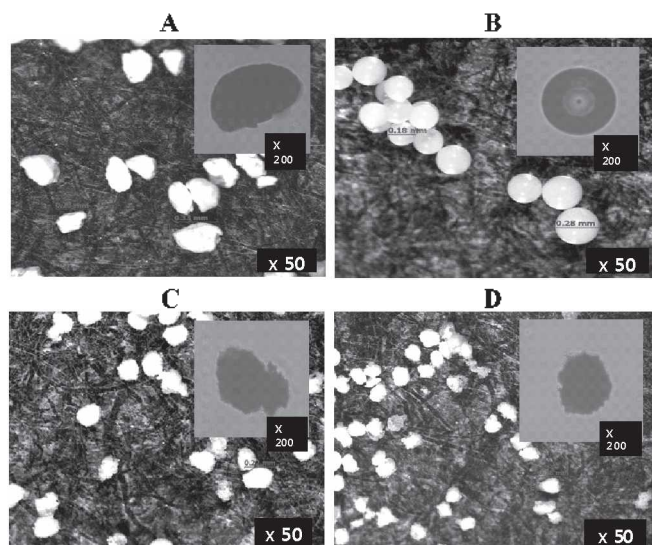

Figure 3. Microscopic images of adsorbents. A, Tenax TA; B, Porapak Q; C, CWAX; and D, OV-1.

as a model compound of monoterpenes. *o*-Cymene has been considered to be one of the major components in amomum fruits.

For each run of HS-MPB- $\mu$ -SPE procedure depicted in Fig. 2 using a Jeonju han-ji in which enclosed several different adsorbents, 10  $\mu$ L of *o*-cymene (0.1 mg/mL methanolic solution) was obtained in a vial (30 mL) and then extracted using 0.6 mL of petroleum ether prior to GC/MS. It can be seen that 0.10 g of Tenax TA or Porapak Q in the amount of adsorbent ranged from 0.01 g to 0.30 g showed the highest peak area (Fig. 4). Tenax TA showed better efficiency compared to Porapak Q while both C-WAX and OV-1 showed no peaks. In our other study<sup>18</sup> using this methodology, Tenax TA was suitable to adsorb phenethyl alcohol and linalyl acetate. According to our earlier study,<sup>14</sup> Tenax TA showed better efficiencies for some compounds such as geraniol, citral, and geranyl acetate while Porapak Q showed better efficiencies for pinene, myrcene, and limonene. However, it was impossible to adsorb efficiently the full range of flavor compounds by Tenax TA alone. 0.10 g of Tenax TA was used for further experiments of HS-MPB- $\mu$ -SPE.

**Optimization of extraction solvents:** The relative extraction efficiencies of petroleum ether, methylene chloride, or chloroform were investigated. In Fig. 5, their efficiencies were compared based on the GC/MS peak area after HS-MPB- $\mu$ -SPE process for the selected working standard of *o*-cymene. Petroleum ether showed significantly higher area than methylene chloride. Interestingly, in the case of chloroform, MPB enclosed Tenax TA was dissolved by chloroform and unable to extract. In our other study<sup>18</sup> using this methodology, petroleum ether showed better efficiencies than ethyl ether and *n*-hexane for phenethyl alcohol and linalyl acetate. The extraction of *o*-cymene was satisfactory when a 0.6 mL volume of petroleum ether was used, as shown in Fig. 6. It was also found that the peak area was decreased in the case of solvent volumes ranged from over 0.6 to 0.9 mL, and the extraction was insufficient. This result suggests the detection response could be decreased with the dilution of analyte. Relatively cleaner extracts were obtained using very small microliter volume of solvent. Therefore, HS-MPB- $\mu$ -SPE compared with conventional solvent

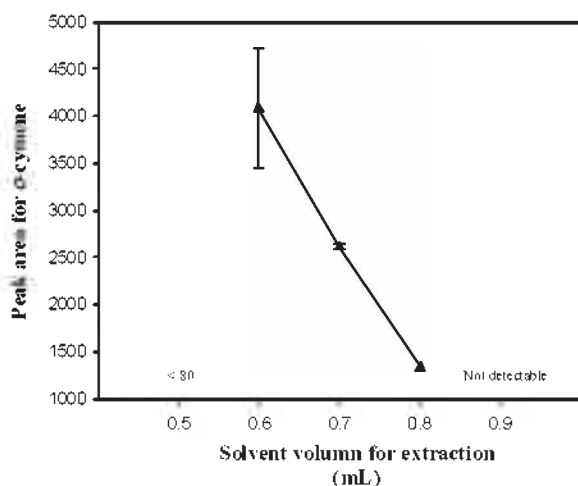

Figure 6. Solvent volume effect for HS-MPB- $\mu$ -SPE and GC/MS.

extraction or SPE can reduce significantly solvent consumption in the sample preparation. Since only sub-mL of solvent is used, there is minimal waste or exposure to toxic organic solvent. In addition, this method allowed combining of extraction, enrichment, and clean-up in a single step.

**Extraction conditions:** The effect of the extraction temperature on the efficiency of HS-MPB- $\mu$ -SPE was tested at 30, 40, 50, and 60 °C. The peak area of *o*-cymene at 40 °C was a little higher than others (Fig. 7). In general, the relatively lower temperature is preferred for the prevention of degradation of thermally labile compounds. Heating at 40 °C is thought to be contributed to the evaporation and adsorption of volatile compounds. However, efficiencies at higher temperatures of 50, and 60 °C were decreased, because the adsorption process could be partially interfered by faster movement of volatile molecules at headspace. The same result was obtained in our other study.<sup>18</sup>

The extraction time profile varied from 30 min to 90 min at 40 °C is shown in Fig. 8. The equilibrium condition for the sorption process of *o*-cymene was almost obtained after 60 min. For further experiments, 40 °C extraction temperature and 60 min extraction time were therefore chosen.

**Comparison of mulberry papers:** Korean Hanji, handmade

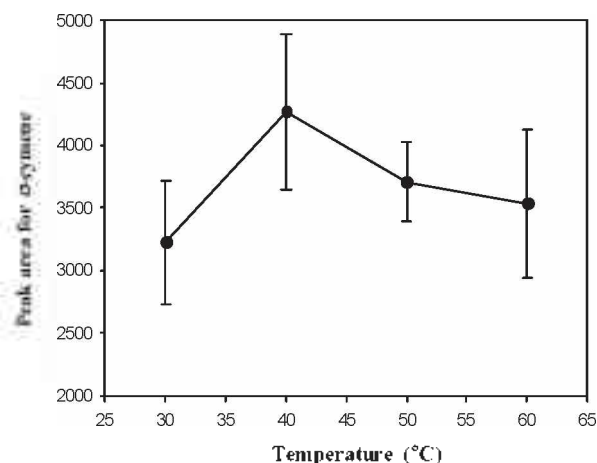

Figure 7. Extraction temperature effect for HS-MPB- $\mu$ -SPE and GC/MS.

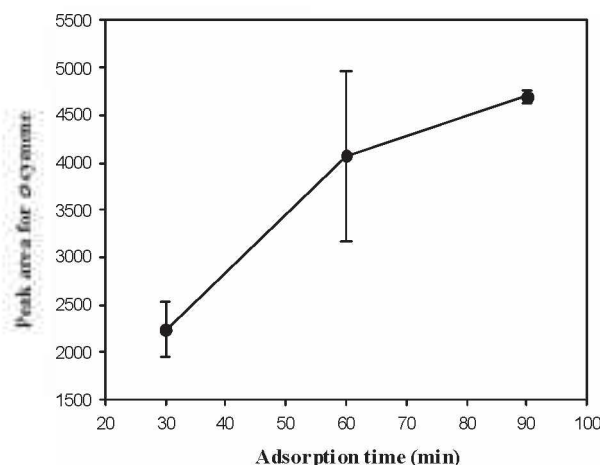

Figure 8. Adsorption time effect for HS-MPB- $\mu$ -SPE and GC/MS.

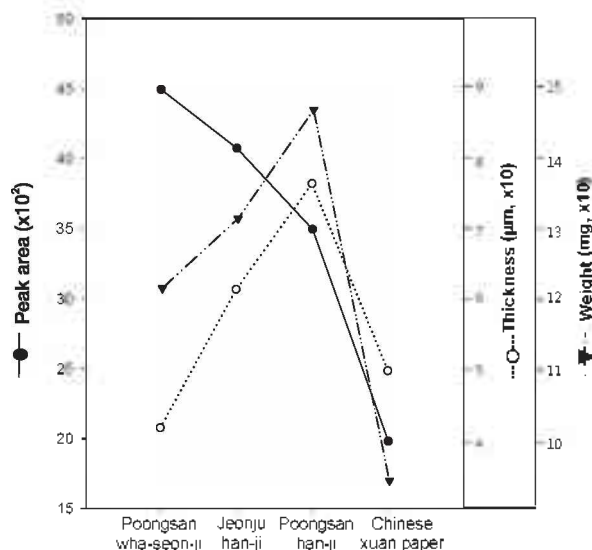

Figure 9. Comparison of different mulberry papers for HS-MPB- $\mu$ -SPE and GC/MS.

Table 1. Thickness and weight of a sheet of mulberry papers (mean  $\pm$  RSD %)

Type of paper	Thickness ( $\mu\text{m}$ )	Weight ( $\text{mg}$ ) <sup>a</sup>
Mulberry paper		
Jeonju han-ji	67.5 ( $\pm$ 2.5)	135.5 ( $\pm$ 1.1)
Poongsan han-ji	79.2 ( $\pm$ 2.1)	148.8 ( $\pm$ 1.1)
Poongsan wha-seon-ji (han-ji for painting)	47.5 ( $\pm$ 3.5)	127.0 ( $\pm$ 1.3)
Qintan tree paper		
Chinese Xuan paper	55.0 ( $\pm$ 3.5)	103.5 ( $\pm$ 4.5)

<sup>a</sup>Size of a sheet: 10.5 cm. length 4.5 cm. width.

mulberry paper. is made by traditional papermaking process from the bast fiber obtained chiefly from Dak tree (mulberry, *Broussonetia kazinoki*). Bast fibers from the phloem (the inner bark or the skin) of mulberry have relatively long length (3 ~ 17 mm) and narrow wideness (13 ~ 42  $\mu\text{m}$ ). Cellulose, lignin, and pentosan are known as chief constituents of its fiber. Microgaps between bast fibers have played an important role to transport volatile molecules from outside of mulberry paper to inside and vice versa.<sup>18</sup> Four different hand-made mulberry papers listed in Table 1 were used to make prototype MPB for  $\mu$ -SPE. HS-MPB- $\mu$ -SPE with an identical procedure as described in experimental section was carried out using hand made MPB which were made of four different mulberry papers. The mulberry paper showed no adsorption peaks of volatile compounds from spice samples when control experiments carried out using only MPB without the adsorbent. Therefore MPB itself has not adsorption properties. As shown in Fig. 9, the peak areas for *o*-cymene were decreased by increasing of the thickness and weight (Table 1) of a sheet of mulberry paper. The thinner Poongsan Whaseonji (0.06 mm. thickness) for painting and calligraphy showed the highest area. However, the Poongsan Whaseonji has a disadvantage too thin to avoid the easy tearing during the extraction process. Meanwhile, lighter and thinner Chinese Xuan paper (0.05 mm. thickness)

showed lower peak area than Jeonju Hanji (0.07 mm. thickness) or Poongsan Hanji (0.08 mm. thickness). Jeonju Hanji was selected to make a MPB for further experiments.

**Validation of HS-MPB- $\mu$ -SPE and comparison with HS-SPME.** Six levels of concentration were tested in triplicate to make calibration curve, these concentrations covered the concentration ranges expected for *o*-cymene in annomum fruit. Good regression ( $y = 13.16x - 1924$ ,  $r^2 = 0.977$ ) was obtained in the range of 0.1 ~ 1  $\mu\text{g}/\mu\text{L}$  of *o*-cymene by HS-MPB- $\mu$ -SPE and GC/MS, while  $y = 1.07x^2 + 69.01x + 18961$  ( $r^2 = 0.998$ ) between 0.05 and 0.6  $\mu\text{g}/\mu\text{L}$  by HS-SPME and GC/MS.

The limit of detection (LOD) for *o*-cymene were 1.3 ng/mL by HS-MPB- $\mu$ -SPE and 0.7 ng/mL by HS-SPME (gray fiber). The limit of quantitation (LOQ) for *o*-cymene were 4.3 ng/mL by HS-MPB- $\mu$ -SPE and 2.3 ng/mL by HS-SPME (gray fiber), respectively. LOD and LOQ were calculated by  $\text{LOD} = 3 \text{ S/N}$  and  $\text{LOQ} = 10 \text{ S/N}$ .

The reproducibility of HS-MPB- $\mu$ -SPE procedure was investigated using working standard of *o*-cymene. Under the optimized conditions described above, the reproducibility of the proposed HS-MPB- $\mu$ -SPE method was 3.3% (RSD) for peak area and 0.03% (RSD) for retention time compared with those of 4.3% and 0.03% by HS-SPME, respectively.

In order to check the accuracy of the method, known quantity (30  $\mu\text{g}$ ) of *o*-cymene was spiked to 1.0 g of annomum fruit. Recoveries for *o*-cymene were 94.0 % (7.7% RSD) by HS-MPB- $\mu$ -SPE and 93.8% (9.1% RSD) by HS-SPME.

**Application of HS-MPB- $\mu$ -SPE for the analyses of five spices.** The present HS-MPB- $\mu$ -SPE technique without further cleanup steps was successfully applied to the analyses of the real samples. Eight spice samples were analyzed by HS-MPB- $\mu$ -SPE and compared with another extraction method of HS-SPME. Comparisons of the results are shown in Fig. 10 and Table 2. The peak numbers shown in Fig. 10 correspond to those indicated in Table 2. It can be seen that Chongqing five spice powders are characterized by very high level of *trans*-anethole (about 55.05% by HS-MPB- $\mu$ -SPE and 96.62% by HS-SPME). It is found that strong *trans*-anethole from star anise or fennel contributes to the major characteristic flavor from five spice powders. The flavor components found were depended on the extraction techniques involved. Significant differences between HS-MPB- $\mu$ -SPE and HS-SPME were the amounts of major and minor flavor components. These differences suggest that Tenax TA and SPME fiber have different selectivity. HS-MPB- $\mu$ -SPE is relatively simple and inexpensive than HS-SPME which has some of the drawbacks of limited life time of the fiber.

## Conclusion

Headspace mulberry paper bag micro solid phase extraction (HS-MPB- $\mu$ -SPE) using Tenax TA prior to GC/MS was newly developed for the determination of flavor components from five spice samples. The HS-MPB- $\mu$ -SPE is very simple to use, inexpensive, rapid, reproducible, low LOD and LOQ, requires small sample amounts and solvent consumption per sample. HS-MPB- $\mu$ -SPE compared with conventional solvent extraction or SPE can reduce significantly solvent consumption

**Table 2.** Composition of flavor components from spice samples by A) HS-MPB- $\mu$ -SPE-GC/MS and B) HS-SPME-GC/MS.

Peak No.	Compound	$t_R$	$M_R$	Normalized peak area (%) for different spice samples(1-8) by A) HS-MPB- $\mu$ -SPE-GC/MS and B) HS-SPME-GC/MS															
				1-A <sup>a</sup>	1-B <sup>a</sup>	2-A <sup>a</sup>	2-B <sup>a</sup>	B3-A <sup>a</sup>	3-B <sup>a</sup>	4-A <sup>a</sup>	4-B <sup>a</sup>	5-A <sup>a</sup>	5-B <sup>a</sup>	6-A <sup>a</sup>	6-B <sup>a</sup>	7-A <sup>a</sup>	7-B <sup>a</sup>	8-A <sup>a</sup>	8-B <sup>a</sup>
1	Furfural	14.96	96	-	-	0.26	2.46	-	-	-	0.05	-	-	-	-	-	-	-	
2	Furfural alcohol	16.77	91	-	-	-	-	2.24	-	-	-	-	-	-	-	-	-	-	
3	$\alpha$ -Pinene	17.10	136	7.92	4.78	3.23	1.44	10.72	2.14	0.39	0.06	0.01	0.08	-	-	-	0.22	0.01	
4	<i>DL</i> -Camphene	16.38	108	2.92	6.54	4.26	2.49	-	2.51	0.27	0.03	-	-	-	-	-	-	-	
5	$\beta$ -Pinene	18.03	136	13.47	0.69	-	-	12.68	5.90	0.11	0.03	0.01	0.02	-	-	-	0.57	0.01	
6	$\beta$ -Myrcene	18.41	136	2.78	1.45	-	-	4.59	4.07	-	-	-	0.02	-	-	-	-	-	
7	Benzyl cinnamate	18.52	105	-	-	-	-	-	-	0.27	0.03	-	-	-	-	-	1.48	0.04	
8	3-Carene	19.11	136	-	-	72.76	21.75	-	3.16	-	-	-	0.04	-	-	-	0.68	0.01	
9	$\alpha$ -Phellandrene	19.24	136	0.72	-	-	-	-	-	-	-	0.02	0.10	-	-	-	0.33	-	
10	Limonene	19.97	136	19.66	9.87	2.47	2.71	24.82	23.29	0.79	0.02	0.39	5.10	-	-	2.82	0.22	6.66	0.07
11	<i>o</i> -Cymene	20.27	136	32.12	19.90	2.58	3.46	-	-	0.77	0.01	-	-	-	-	1.99	-	3.93	0.03
12	Cineol	20.79	154	-	-	-	-	19.74	11.17	-	-	0.05	0.12	-	-	-	-	-	-
13	Ocimene	20.99	154	7.64	20.73	1.02	0.90	14.32	8.85	-	-	-	-	-	-	-	-	2.30	0.04
14	$\gamma$ -Terpinene	21.55	136	0.88	0.46	0.17	-	2.91	5.75	-	-	0.01	0.02	-	-	0.83	0.14	0.26	0.01
15	(-)-Linalool	23.03	136	2.90	4.21	-	-	1.36	6.70	-	-	0.02	0.02	-	-	-	-	-	-
16	4-Allylveratrole	23.12	178	-	-	0.25	0.72	-	-	-	-	-	-	-	-	-	-	-	-
17	Fenchone	23.17	152	-	-	-	-	-	-	-	-	-	0.03	-	-	2.30	3.68	0.87	0.04
18	(+)-Camphor	25.38	152	3.15	10.86	-	-	-	-	-	-	-	-	-	-	-	0.48	-	-
19	Isoborneol	25.42	154	0.91	2.75	-	-	-	-	-	-	-	-	-	-	-	-	0.23	0.01
20	Borneol	25.83	154	1.05	5.80	2.05	1.14	2.80	7.35	0.41	0.01	0.01	0.02	-	-	-	-	0.19	0.01
21	Methyl chavicol	26.26	148	-	-	-	-	-	-	-	-	0.06	0.09	-	0.02	4.96	1.06	17.64	1.24
22	$\alpha$ -Terpineol	26.45	154	-	-	-	-	1.67	2.69	-	-	0.01	0.01	-	-	-	-	-	-
23	<i>trans</i> -Cinnamaldehyde	27.91	132	-	-	-	-	-	-	0.19	0.04	-	-	-	-	-	-	0.51	0.04
24	Bornyl acetate	28.94	196	-	-	-	-	1.07	9.17	-	-	-	-	-	-	-	-	-	-
25	<i>trans</i> -Anethole	29.25	148	0.42	3.44	-	1.54	-	-	-	0.08	99.35	94.22	-	-	79.69	92.13	55.05	96.62
26	Anisaldehyde	29.93	136	-	-	-	-	-	-	-	-	-	-	-	-	2.45	1.96	2.34	0.75
27	Cavacrol	30.23	150	-	-	-	-	-	-	-	-	-	-	1.45	0.01	-	-	-	-
28	Cinnamaldehyde	30.43	132	-	-	-	-	-	-	14.98	8.22	-	-	-	-	-	-	0.19	0.08
29	Terpinyl acetate	30.54	196	-	-	-	-	1.08	6.27	-	-	-	-	-	-	-	-	-	-
30	Cinnamyl alcohol	30.94	134	0.32	1.02	-	-	-	-	65.70	68.56	0.01	0.02	1.18	0.10	-	-	5.93	0.67
31	Eugenol	31.77	164	-	-	-	-	-	-	2.08	1.56	-	-	63.54	80.96	3.13	-	-	-
32	$\beta$ -Caryophyllene	31.79	204	1.75	4.58	-	-	-	0.17	-	-	0.01	0.01	-	-	-	-	-	-
33	Farnesecene	32.25	204	-	-	2.75	8.32	-	-	-	3.35	0.03	0.06	-	-	-	-	0.25	0.03
34	$\alpha$ -Caryophyllene	34.45	204	1.39	0.92	5.60	36.62	-	0.81	2.80	7.43	0.01	0.02	31.87	18.90	1.83	-	0.49	0.18
35	Eugenol acetate	34.26	206	-	-	-	-	-	-	-	-	-	-	1.96	0.01	-	-	-	-
36	Cinnamyl acetate	34.99	176	-	-	1.75	12.59	-	-	7.85	5.60	-	-	-	-	-	-	0.21	0.06
37	Propenoic acid-2-[4-buten-3-yl]phenyl]-methyl ether	35.88	218	-	-	-	-	-	-	3.10	4.52	-	-	-	-	-	-	-	-
38	Caryophyllene oxide	39.31	220	-	2.00	-	-	-	-	0.16	0.28	-	-	-	-	-	-	-	-
39	Azulene, 1,4-dimethyl 1-7-(1-methylethyl)-	39.07	198	-	-	-	-	-	-	0.13	0.12	-	-	-	-	-	-	-	-
40	Ethyl <i>m</i> -methoxy Cinnamate	39.69	206	-	-	-	1.71	-	-	-	-	-	-	-	-	-	-	-	0.03
41	Ethyl <i>p</i> -methoxy cinnamate	43.55	206	-	-	0.85	2.15	-	-	-	-	-	-	-	-	-	-	-	0.02

<sup>a</sup>1, Amomum fruit; 2, Galangal rhizome; 3, Sichuan pepper; 4, Cinnamon bark; 5, Star anise; 6, Clove buds; 7, Fennel seed; 8, Five spice powder  
A, HS-MPB-*m*-SPE; B, SPME. - not detected

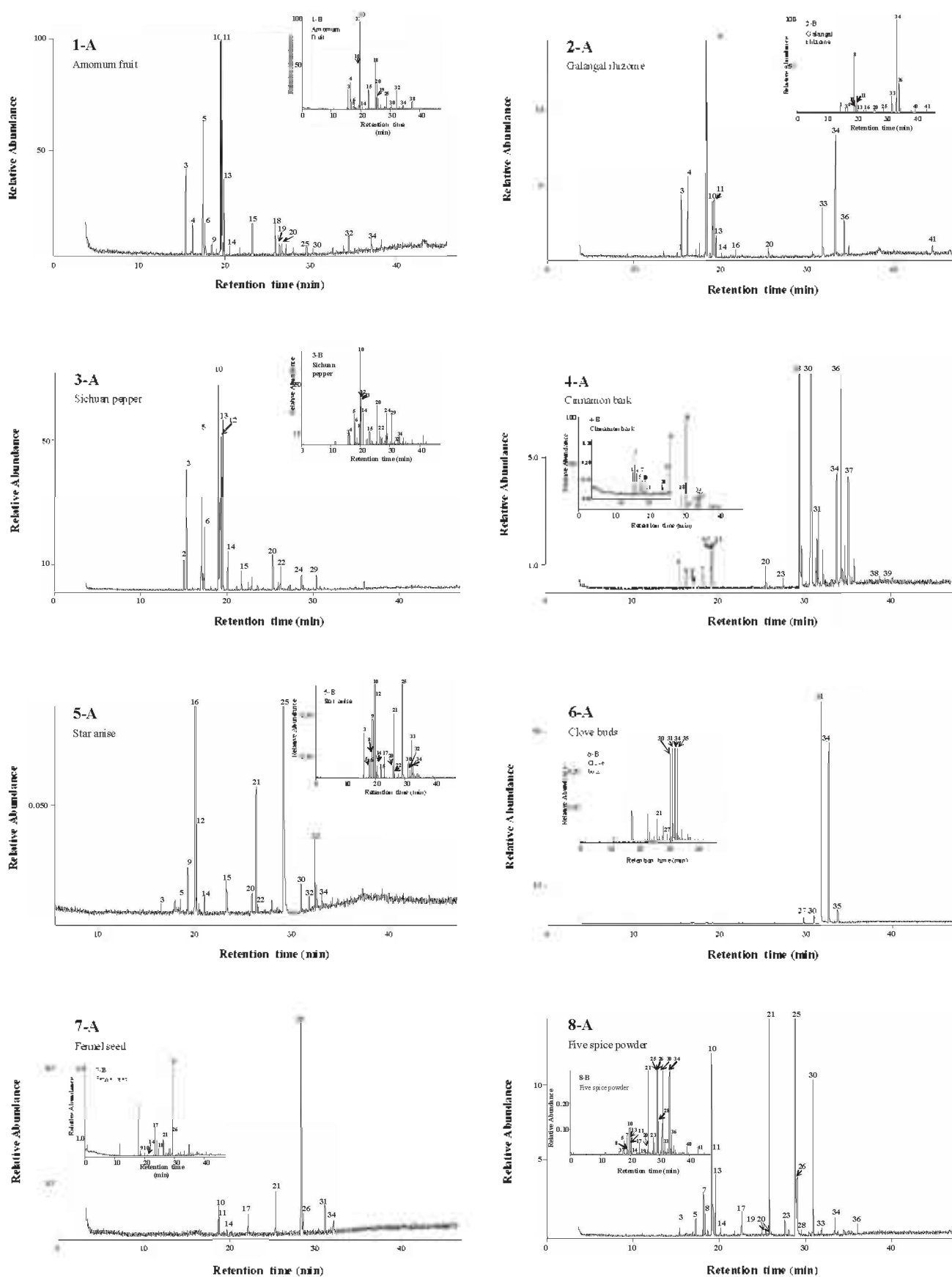

Figure 10. Comparison of total ion chromatograms obtained by A, HS-MPB- $\mu$ -SPE-GC/MS and B, HS-SPME with GC/MS. 1, Amomum fruit 2, Galangal rhizome 3, Sichuan pepper; 4, Cinnamon bark; 5, Star anise; 6, Clove buds; 7, Fennel seed and 8, Five spice powders.

in the sample preparation. In addition, this method allowed combining of extraction, enrichment, and clean-up in a single step. This method allowed successful determination of flavor compounds from five spice samples. Strong *trans*-anethole from star anise or fennel is a characteristic flavor of five spice powders. HS-MPB- $\mu$ -SPE and GC/MS could be a promising versatile technique of the measurement of volatile flavor compounds from spices.

**Acknowledgments.** This work was supported by a special research grant from Seoul Women's University in 2008.

### References

1. Kim, N. S.; Lee, D. S. *J. Chromatogr. A* **2002**, *982*, 31.
2. Augusto, F.; Leite e Lopes, A.; Zini, C. A. *Trends Anal. Chem.* **2003**, *22*, 160.
3. Siato, Y.; Ueta, I.; Ogawa, M.; Hayashida, M.; Jinno, K. *J. Pharm. Biomed. Anal.* **2007**, *44*, 1.
4. Bicchi, C.; Cordero, C.; Liberto, E.; Sgorbini, B.; Rubiolo, P. *J. Chromatogr. A* **2008**, *1184*, 220.
5. Arthur, C. L.; Pawliszyn, J. *Anal. Chem.* **1990**, *62*, 2145.
6. Lee, S. N.; Kim, N. S.; Lee, D. S. *Anal. Bioanal. Chem.* **2003**, *4*, 749.
7. Yoo, Z. W.; Kim, N. S.; Lee, D. S. *Bull. Korean Chem. Soc.* **2004**, *25*, 271.
8. Kim, N. S.; Lee, D. S. *J. Sep. Sci.* **2004**, *27*, 96.
9. Bicchi, C.; Drigo, S.; Rubiolo, P. *J. Chromatogr. A* **2000**, *892*, 469.
10. Deng, C.; Wang, A.; Shen, S.; Fu, D.; Chen, J.; Zhang, X. *J. Pharm. Biomed. Anal.* **2005**, *38*, 326.
11. Deng, C.; Yao, N.; Wang, A.; Zhang, X. *Anal. Chim. Acta* **2005**, *536*, 237.
12. He, Y.; Lee, H. K. *Anal. Chem.* **1997**, *69*, 4634.
13. Jung, M. J.; Shin, Y. J.; Oh, S. Y.; Kim, N. S.; Kim, K.; Lee, D. S. *Bull. Korean Chem. Soc.* **2006**, *27*, 231.
14. Kim, H. J.; Kim, K.; Kim, N. S.; Lee, D. S. *J. Chromatogr. A* **2000**, *902*, 389.
15. Shin, Y. J.; Jung, M. J.; Kim, N. S.; Kim, K.; Lee, D. S. *Bull. Korean Chem. Soc.* **2007**, *28*, 2389.
16. Lee, D. S.; Kim, N. S. *Bull. Korean Chem. Soc.* **2002**, *23*, 1647.
17. Kim, N. S.; Lee, D. S. *Anal. Sci., Supplement of ASLANALYSIS VI* **2001**, *17a*, 383.
18. Won, M. M.; Cha, E. J.; Yoon, O. K.; Kim, N. S.; Kim, K.; Lee, D. S. *Anal. Chim. Acta* **2009**, *631*, 54.