

# Differential Dual-Frequency Antenna for Wireless Communication

Liping Han, Wenmei Zhang, Guorui Han, Runbo Ma, and Li Li

*ABSTRACT*—A novel differential dual-frequency antenna using proximity coupling is proposed. Dual bands are realized by a slot in the ground plane. The lower resonant frequency is controlled by the slot in the ground plane, and the upper resonant frequency is mainly determined by the dimensions of the radiating patch. Measured results show that the proposed antenna can operate at 2.51 GHz and 5.38 GHz.

*Keywords*—Differential antenna, dual-frequency antenna, proximity coupling, radiation pattern, dog-bone slot.

## I. Introduction

In recent years, increasing competition in the wireless communication market has generated the need for fully integrated radio frequency (RF) front-end solutions, for which differential signals are preferable. Because most conventional antennas are single-port devices, a balun is usually used to connect the single-feed antenna and integrated circuits. However, the use of a balun brings about loss and efficiency problems and does not achieve a fully integrated solution. When the antenna is excited with a differential signal, the balun is no longer necessary. Recently, several kinds of differential antennas have been reported [1]-[3].

Dual-frequency antennas have become necessary in recent wireless communication systems, such as GPS, GSM, PCS, and IMT-2000, and numerous antenna designs for dual-frequency operation have been reported [4]-[6]. In this letter, a novel differential proximity-coupled dual-frequency antenna is

proposed. Dual bands are realized by a slot in the ground plane, which controls the lower resonant frequency. The upper resonant frequency is mainly controlled by the dimensions of radiating patch. Experimental results show that the proposed antenna can operate at 2.51 GHz and 5.38 GHz, with good agreement between the simulated and measured results.

## II. Theory

The differential antenna can be treated as a two-port network. Based on the  $Z$  parameters of the two ports, the differential voltage as given in [7] is

$$V_d = V_1 - V_2 = (Z_{11} - Z_{21})I_1 - (Z_{22} - Z_{12})I_2, \quad (1)$$

where  $V_d$  is the differential voltage,  $V_1$  and  $V_2$  are the driving voltages of the two ports, and  $I_1$  and  $I_2$  are the driving currents of the two ports. The driving currents of the two ports satisfy

$$I_1 = -I_2 = I. \quad (2)$$

Thus, the input impedance of the differential antenna can be described as

$$Z_d = \frac{V_d}{I} = 2(Z_{11} - Z_{21}) = 2(Z_{22} - Z_{12}). \quad (3)$$

## III. Antenna Design

The configuration and photos of the proposed antenna are shown in Figs. 1 and 2, respectively. In Fig. 1, the top layer is substrate 1 with a rectangular patch antenna, the middle layer is substrate 2 with a feed line, and the bottom layer is the ground plane with a slot etched in the middle. The radiating patch is split into two parts to enhance the gain because the separated radiating patches can achieve stronger directivity. The dog-

Manuscript received Jun. 17, 2008; revised July 11, 2008; accepted Oct. 22, 2008.

This work was supported by the National Science Foundation of China (No. 60771052), the Natural Science Foundation of Shanxi province (No. 2006011029) and the Science and Technology Foundation of Taiyuan city (No.0703004).

Liping Han (phone: + 86 351 7011433, email: ping\_sx@yahoo.com.cn), Wenmei Zhang (email: zhangwm@sxu.edu.cn), Guorui Han (email: han\_gr@sxu.edu.cn), Runbo Ma (email: marunbo@sxu.edu.cn), and Li Li (email: lilil@sxu.edu.cn) are with the College of Physics and Electronics Engineering, Shanxi University, Taiyuan, China.

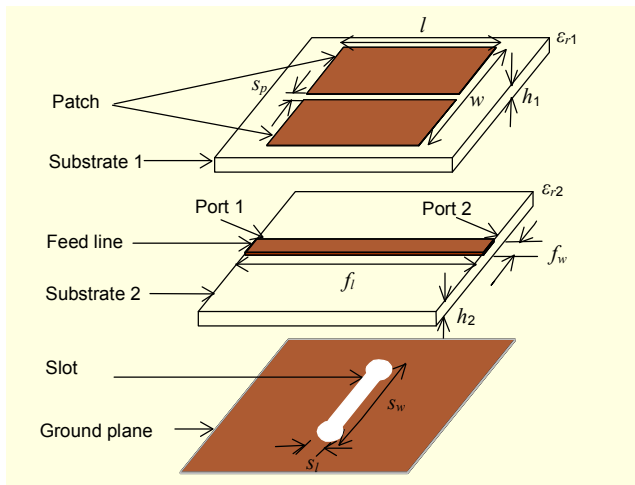

Fig. 1. Configuration of the antenna.

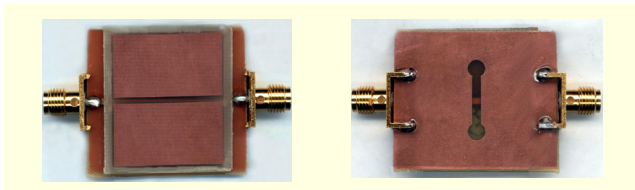

Fig. 2. Photos of the antenna: (a) top view and (b) bottom view.

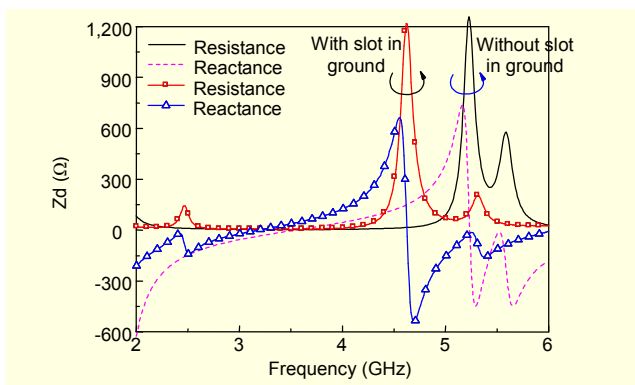

Fig. 3. Simulated input impedance with and without slot in ground.

bone slot in the ground provides the highest bandwidth among the common geometries. The antenna was fabricated with the following parameters:  $\epsilon_{r1}=\epsilon_{r2}=4.4$ ,  $h_1=1.6$  mm,  $h_2=0.8$  mm,  $w=30$  mm,  $l=26$  mm,  $f_i=34$  mm,  $f_w=1.4$  mm,  $s_f=2$  mm,  $s_w=18$  mm, and  $s_p=1.4$  mm, respectively.

For the normal differential proximity-coupled antenna, the rectangular patch antenna is usually operated as a half-wavelength antenna. When a slot is employed in the ground, a new resonant mode with its resonant frequency lower than that of the  $TM_{10}$  mode can be excited. Therefore, the lower resonant frequency of the proposed antenna is controlled by the slot in the ground due to the change of input impedance, and the upper frequency is mainly determined by the dimensions of the

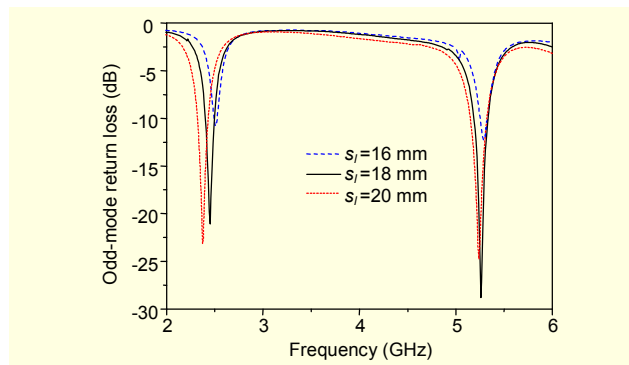

Fig. 4. Simulated effect of slot length on odd-mode return loss.

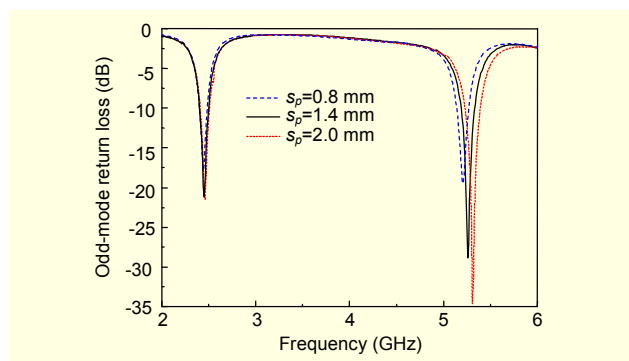

Fig. 5. Simulated effect of patch spacing on odd-mode return loss.

radiating patch due to the half-wavelength structure.

The simulated input impedance of antennas with and without a slot in the ground is shown in Fig. 3. Note that if a slot is not used, there is a good matching point in the input impedance curve. When a slot is employed, two points with good matching appear; thus, the antenna can operate at two frequencies. The results show that the proposed antenna resonates at 2.45 GHz and 5.25 GHz.

The slot in the ground is a major factor affecting the resonant frequencies, as is the spacing of the two patches. Figures 4 and 5 show the effect on odd-mode return loss of slot length and patch spacing, respectively. As Fig. 4 shows, both frequencies decrease with the slot length. In Fig. 5, it is clear that the upper frequency increases with the patch spacing, and the lower frequency is not sensitive to the patch spacing.

#### IV. Experimental Results

Figure 6 shows the odd-mode return loss of the antenna. Close agreement between simulated and measured results is obtained. The measured impedance bandwidth for  $s_{11} < -10$  dB is about 4.4% at 2.51 GHz and 3.1% at 5.38 GHz. Due to the fabrication tolerance and measurement errors, the frequency shifts at the two resonate frequencies by 2.4% and 2.5%.

Measured radiation patterns of the antenna at both bands are

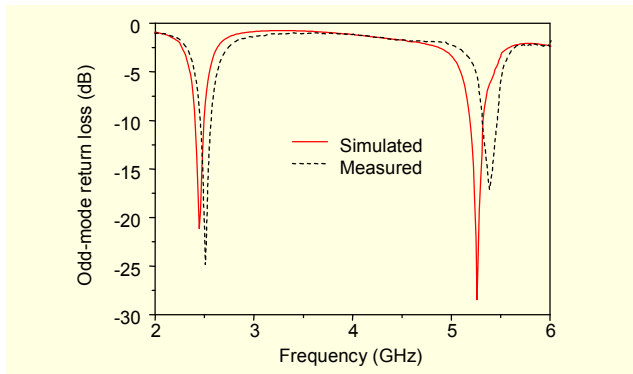

Fig. 6. Simulated and measured odd-mode return loss.

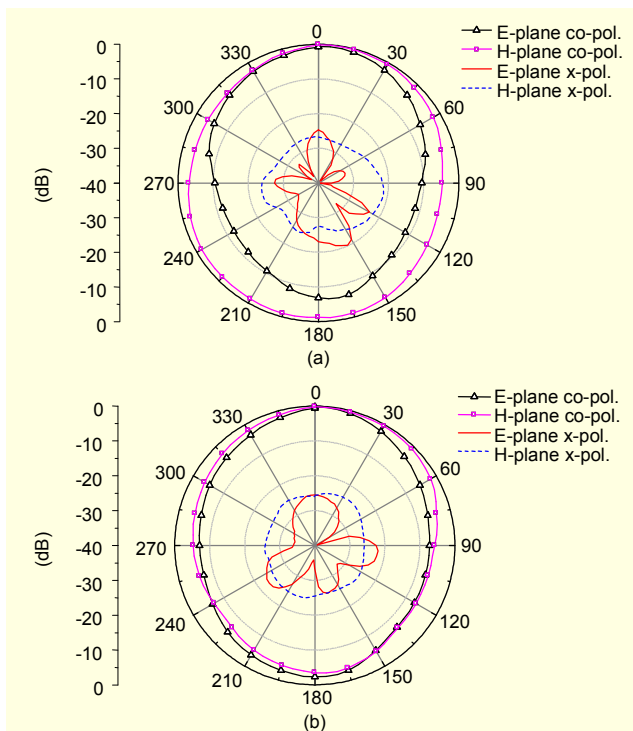

Fig. 7. Measured radiation pattern of the antenna: (a) at lower band and (b) at upper band.

shown in Fig. 7. The H-plane radiation pattern is nearly omnidirectional, and the E-plane pattern is somewhat symmetric. The cross-polarization level is about 21 dB at both bands.

Figure 8 shows the measured gain of the antenna at both bands. Gain is above 1.5 dBi and 2.5 dBi across the lower band and the upper band, respectively. The peak gain at the two frequencies is 2.06 dBi and 3.42 dBi, and the antenna efficiency is about 86%.

## V. Conclusion

In this letter, a novel differential dual-frequency antenna using a proximity coupling technique was demonstrated.

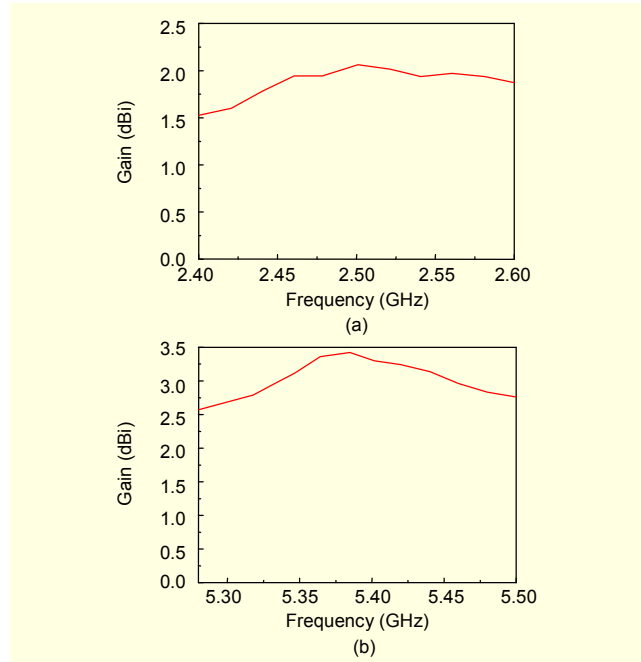

Fig. 8. Measured gain of the antenna: (a) at lower band and (b) at upper band.

Experimental results show that the antenna can operate at 2.51 GHz and 5.38 GHz. The proposed antenna is convenient to integrate with RF front-end, and is suitable for wireless communication applications.

## References

- [1] E. Lee et al., "Active Integrated Antenna Design Using a Contact-Less, Proximity Coupled, Differentially Fed Technique," *IEEE Trans. Antennas and Propagation*, vol. 55, no. 2, Feb. 2007, pp. 267-276.
- [2] K.M. Chan et al., "Differential Aperture Coupling Technique for Passive and Active Integrated Antenna Design," *IET Microwaves, Antennas and Propagation*, vol. 1, no. 2, Apr. 2007, pp. 458-464.
- [3] Y.P. Zhang, "Design and Experiment on Differentially-Driven Microstrip Antennas," *IEEE Trans. Antennas and Propagation*, vol. 55, no. 10, Oct. 2007, pp. 2701-2708.
- [4] R.K. Raj et al., "A New Compact Microstrip-Fed Dual-Band Coplanar Antenna for WLAN Applications," *IEEE Trans. Antennas and Propagation*, vol. 54, no. 12, Dec. 2006, pp. 3755-3762.
- [5] L. Liu, S. Zhu, and R. Langley, "Dual-band Triangular Patch Antenna with Modified Ground Plane," *Electronics Letters*, vol. 43, no. 3, Feb. 2007, pp. 140-141.
- [6] Y. Song et al., "Compact Printed Monopole Antenna for Multiband WLAN Applications," *Microwave and Optical Technology Letters*, vol. 50, no. 2, Feb. 2008, pp. 365-367.
- [7] Y.P. Zhang and J.J. Wang, "Theory and Analysis of Differentially-Driven Microstrip Antennas," *IEEE Trans. Antennas and Propagation*, vol. 54, no. 4, Apr. 2006, pp. 1092-1099.