

JPE 8-2-1

An 18-Pulse Full-Wave AC-DC Converter for Power Quality Improvement

Bhim Singh* and Sanjay Gairola†

†*Dept. of Electrical and Electronics Eng., Indian Institute of Technology, Delhi, New-Delhi, India

ABSTRACT

In this paper, a novel delta/double-fork transformer based 18-pulse full-wave AC-DC converter is designed, modeled, simulated and developed to feed isolated DC varying loads. The proposed AC-DC converter is used for low voltage and large current DC loads in applications such as electrowinning, where isolation is required mainly for stepping down the supply voltage. The proposed converter improves power quality at AC mains and meets IEEE-519 standard requirements at varying loads.

Keywords: 18-pulse, Fork connection, AC-DC converter, Power quality

1. Introduction

Three-phase AC-DC conversion is commonly carried out using two circuit arrangements: (1) Full-wave AC-DC converters or (2) Bridge AC-DC converters. The differences between the two, which are useful to emphasize their role for different applications, are given in Table 1. Low-voltage and high current applications require minimum drop in the voltage due to source impedance, leakage reactance and in devices used in the path of the load current. Full-wave rectifiers have only one device in the path of the load current and are preferred in industrial applications such as electro-chemical and induction heating processes, plasma torches, etc.

A six-phase full-wave rectifier is shown in Fig. 1, which employs a delta/ double-star transformer (ANSI 45 configuration) and an interphase reactor (IPR). A diode is

connected in each output phase for rectification. (This technology is well established.) Two three-phase output groups are connected so that one is of opposite instantaneous polarity to the other. This mutual disposition of 180° would give a six-phase diametric vector if no interphase reactor (IPR) or interphase transformer (IPT) were present and the two neutrals were directly connected [1]. However, each device conducts for 60° , so the interphase reactor (IPR) as shown in Fig. 1 separates the six phase star in two groups, with greatly improved diode

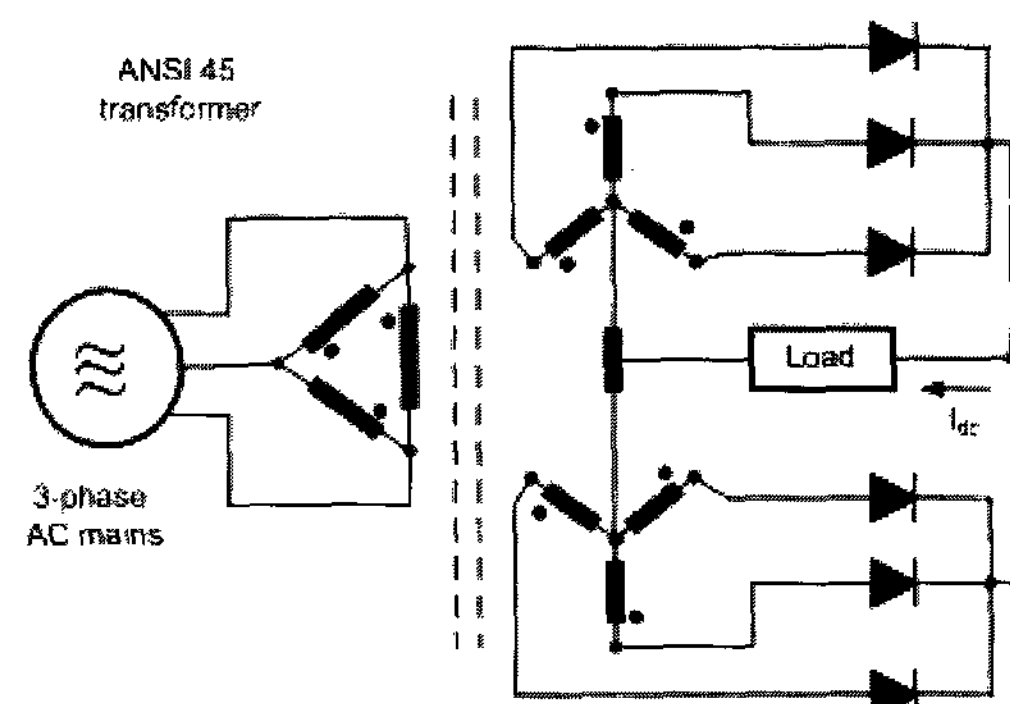

Fig. 1 A 6-phase full-wave uncontrolled AC-DC converter using delta/double-star transformer (ANSI 45 rectifier)

Manuscript received Sept. 10, 2007; revised Dec. 15, 2007

† Corresponding Author: sanjaygairola@gmail.com

Tel: +91-11-26591045, Fax: +91-11-26581606, I.I.T. Delhi, India

*Dept. of Electrical and Electronics Eng., I.I.T. Delhi, India

Table 1 Comparison of Full-wave and Bridge AC-DC converters

S. No.	Full-Wave AC-DC Converter	Bridge AC-DC Converter
1	There is only one device in path of load current.	There are two devices in path of load current.
2	The DC voltage produced corresponds to applied phase voltage. $V_{dc} = \sqrt{2} (p/\pi) \sin(p/\pi) V_{phase}$, where p is the pulse number of AC-DC Converter	The DC voltage produced corresponds to applied line voltage. $V_{dc} = \sqrt{2} (p/\pi) \sin(p/\pi) V_{line}$, where p is the pulse number of AC-DC Converter
3	These are especially suitable for applications where load current is very high as the losses in devices will be less.	These are suitable for medium and low value currents.
4	The presence of transformer is must as the centretap is needed.	The presence of transformer is not essential (as in 6-pulse AC-DC converter) as the centretap is not needed
5	These do not lend themselves for all types of multipulse AC-DC converter configuration as the mmf balance is achieved mainly in multiphase arrangements only. The reason is that the transformer windings carry unidirectional currents and so to reset the flux in core, the transformer should have another winding of opposite polarity in same phase to reset the flux.	These lend themselves easily for different multipulse AC-DC converter configurations as transformer windings carry bidirectional currents, resetting the flux in the transformer core.

and transformer utilization. Each group commutates by itself so that the diode conduction period is 120° . The IPR absorbs the instantaneous voltage difference between the two commutating groups and allows them to operate independently.

It is a common practice to use multiple 12-pulse or 18-pulse AC-DC converter units fed from such phase-staggered transformers to meet IEEE-519 standard [2] requirements as the total harmonic distortion (THD) of the input line currents of a single unit is high and may not qualify as clean power at high loads. The isolation transformers used for high currents can have different winding arrangements such as star, delta, fork, zig-zag, and polygon. The isolation transformers used for full-wave rectifiers generally have delta or star primary windings (sometimes polygon windings also) and star, zigzag or fork secondary windings. The star, zigzag and fork windings provide a neutral point for full-wave rectifiers; however, two secondary windings must have interphase reactors between neutral points as shown in Fig. 1. Unfortunately, a six-phase full-wave AC-DC converter affects the power quality at the point of common coupling (PCC) by injecting harmonics into AC mains and, thus, affecting the neighbouring consumers. Due to this reason ANSI 45 and ANSI 46 transformers [3-4] are employed

together as shown in Fig. 2 to make a full-wave 12-pulse AC-DC converter. Maslin et. al. [5] reported a 12-phase full-wave AC-DC converter based on zigzag transformers for electrical induction apparatus as early as 1943. This twelve-pulse converter uses two three-phase transformers having star and delta primary windings but identical zigzag secondary windings. This rectifier configuration is reported to use seven interphase reactors. However, it is observed that the total harmonic distortion (THD) of the input current is more than 8% in all these cases and tuned passive filters are extensively used.

ANSI 45 and ANSI 46 rectifier combinations are also described by Brown [6] for the copper electrowinning industry. A twelve-pulse full-wave AC-DC converter fed from transformers with delta and polygon primary windings is also described by Wiechmann et. al. [7] for the same application. A novel transformer connection in which primary windings of different transformers are connected in series and identical secondary windings for full-wave rectification is described by Oliver et. al. [8] that doesn't require IPRs. However, it has complex primary winding connections for higher pulse numbers and a greater number of transformers are needed, thereby making reliability of the system poor. Miyari et. al. [9] have explained a method of pulse multiplication in 6-pulse

full-wave rectifiers but it adds one more semiconductor device in the path of the load current. An 18-pulse diode bridge based front end AC-DC converter for electrolytic applications is explained by Wiechmann et. al.^[10]. This topology also has two devices in the path of the load current and, hence, additional voltage drop and losses, which are not desired on the secondary side, as the load current is very large.

In this paper a novel 18-phase full-wave AC-DC converter is proposed for low-voltage high current applications. The developed 18-pulse rectifier is fed from a delta/fork-fork transformer. The input transformer secondary winding is a symmetric fork extending two sets of 9-phases for the two nine-diode full-wave converters. A detailed design of the transformer and resulting 18-pulse diode rectifier system is carried out to study the behavior of this converter. The designed converter system is modeled and simulated in MATLAB to demonstrate power quality improvement at AC mains. A prototype is developed in the laboratory to validate the proposed model and design of the 18-pulse AC-DC converter.

2. Proposed 18-Phase AC-DC Converter

Fig. 3 shows the proposed 18-phase full-wave AC-DC converter. In this configuration delta primary winding and fork connected secondary windings are used. Each secondary winding produces a set of 9-phase supply for full-wave converters.

2.1 Design of delta/fork transformer for 18-pulse AC-DC Converter

Fig. 4a shows the schematic diagram of the proposed delta/double fork transformer winding arrangement and its connection to two nine-diode full-wave AC-DC converters, FW1 and FW2. Two nine-diode full-wave converters FW1 and FW2 are connected to two sets of nine-phase secondary at (B11, B12, B13,...B19) and (B21, B22, B23,...B29), respectively. Fig. 4b depicts the graphical representation of the transformer secondary and angular position of various voltage phasors. Two sets of nine phase voltages are ($V_{B11}, V_{B12}, V_{B13}, V_{B14}, V_{B15}, V_{B16}, V_{B17}, V_{B18}, V_{B19}$) and ($V_{B21}, V_{B22}, V_{B23}, V_{B24}, V_{B25}, V_{B26}, V_{B27}, V_{B28}, V_{B29}$). These sets are displaced by 20° from each

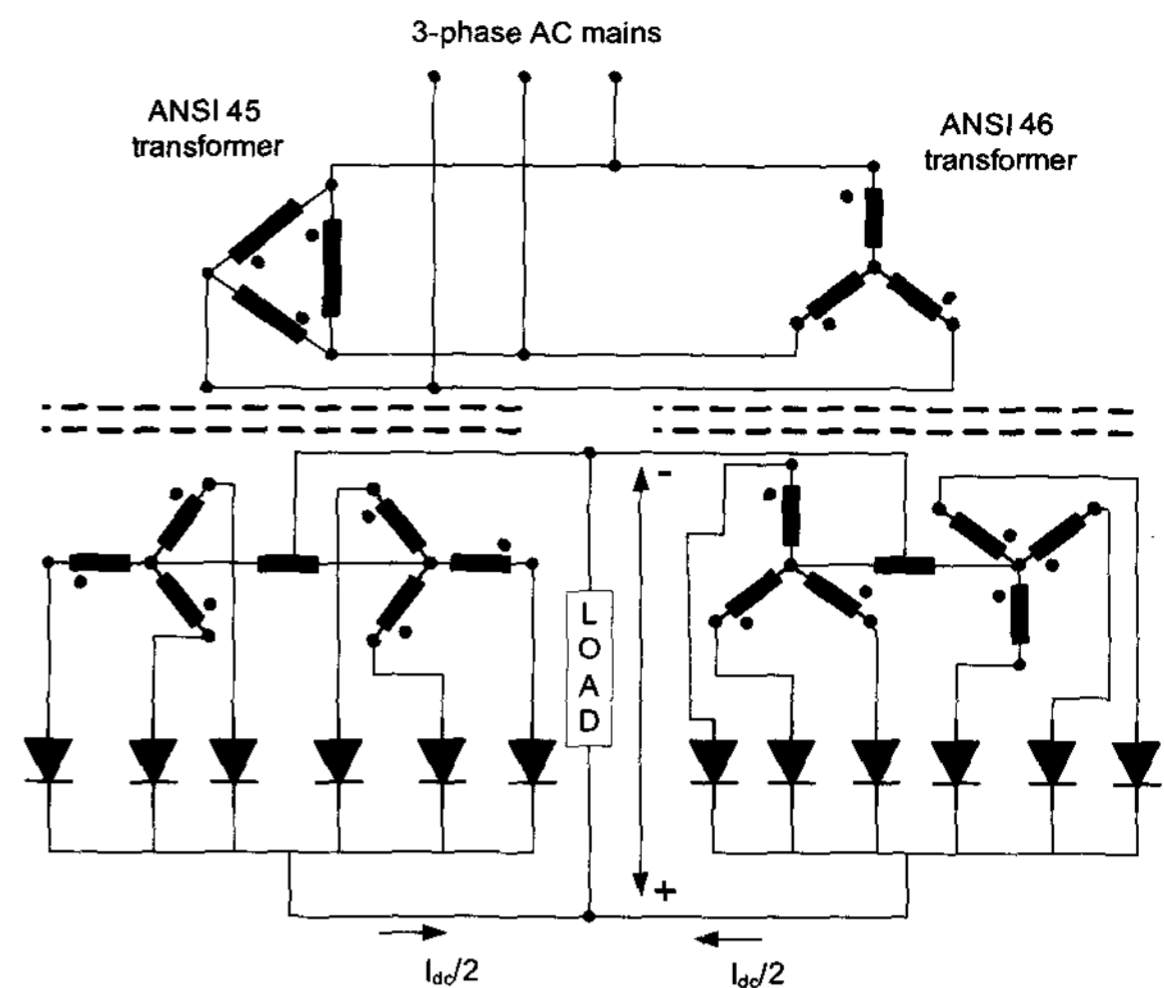

Fig. 2 A delta/double star transformer (ANSI 45) and star/double star transformer (ANSI 46) combination for 12-pulse full-wave AC-DC conversion

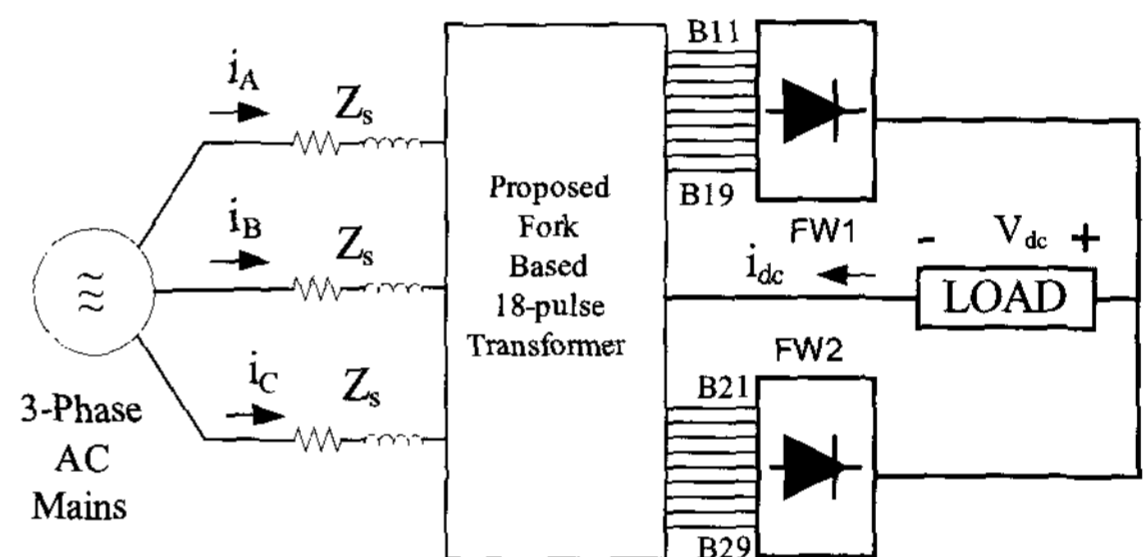

Fig. 3 Proposed delta/fork transformer based 18-pulse AC-DC converter

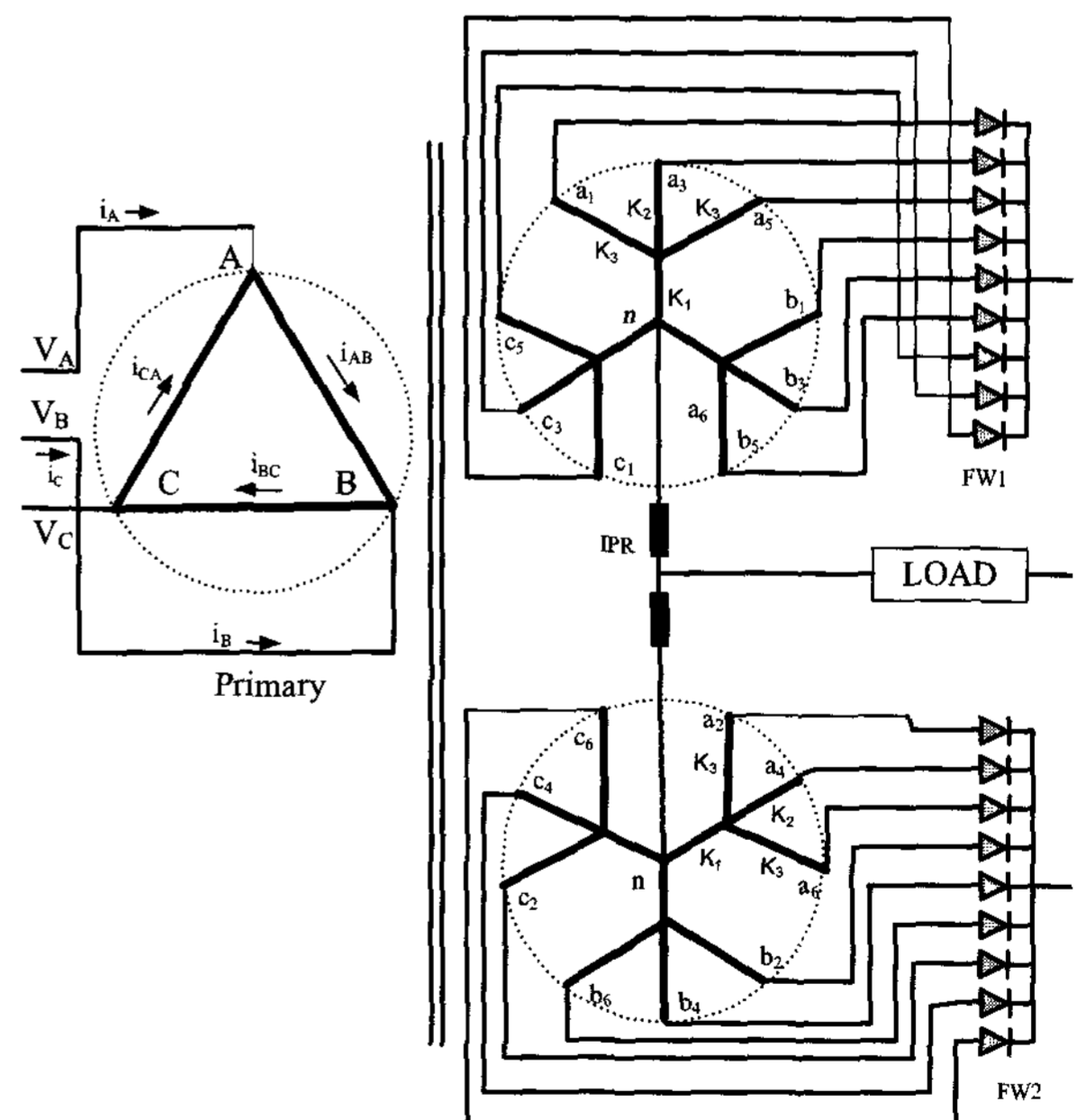

Fig. 4a Delta/ double fork transformer winding arrangement for 18-phase full-wave AC-DC conversion

other and at 0° and $+20^\circ$ respectively from voltage V_R , where V_R is the secondary voltage phasor in the direction of the supply phase voltage V_A . The number of turns in every winding is determined as a function of the required secondary voltage, V_R . These secondary voltages, as marked in Fig. 4, are expressed by the following relationships.

Let the transformation ratio of the transformer be a,

$$a = V_A / V_R \quad (1)$$

The required voltages for the converter I (FW1) are:

$$\begin{aligned} V_{B11} &= V_R \angle 0^\circ, V_{B12} = V_R \angle -40^\circ, V_{B13} = V_R \angle -80^\circ, \\ V_{B14} &= V_R \angle -120^\circ, V_{B15} = V_R \angle -160^\circ, V_{B16} = V_R \angle -200^\circ, \\ V_{B17} &= V_R \angle -240^\circ, V_{B18} = V_R \angle -280^\circ, V_{B19} = V_R \angle -320^\circ \end{aligned} \quad (2)$$

The required voltages for the converter II (FW2) are:

$$\begin{aligned} V_{B21} &= V_R \angle 20^\circ, V_{B22} = V_R \angle -20^\circ, V_{B23} = V_R \angle -60^\circ, \\ V_{B24} &= V_R \angle -100^\circ, V_{B25} = V_R \angle -140^\circ, V_{B26} = V_R \angle -180^\circ, \\ V_{B27} &= V_R \angle -220^\circ, V_{B28} = V_R \angle -260^\circ, V_{B29} = V_R \angle -300^\circ \end{aligned} \quad (3)$$

The values of constants K_1 to K_3 marked in Fig. 4a determine the secondary winding turns as a fraction of primary windings turns. These values can be determined by solving the following equations:

$$V_{B11} = (K_1 + K_2)V_R \quad (4)$$

$$V_{B19} = K_1 V_R - K_3 V_R \angle -120^\circ \quad (5)$$

$$V_{B12} = K_1 V_R - K_3 V_R \angle 120^\circ \quad (6)$$

Eqns. (4-6) give the values of constants K_1 to K_3 for desired phase shift as

$$K_1 = 0.3949, K_2 = 0.6051, K_3 = 0.7422 \quad (7)$$

2.2 Transformer rating for the 18-Pulse AC-DC converter

The rating of a transformer is dependent on the voltage across each winding and the current through them. The winding voltages determine the core size while the currents determine the conductor size and, hence, the two determine its equivalent VA rating^[11]. The VA rating of these transformers is calculated as:

$$VA \text{ rating} = 0.5 \sum (V_k I_k) \quad (8)$$

Where, V_k and I_k are the root-mean-square (r.m.s.) value of the voltage across and current through the k^{th} winding. The same relation is used for estimating the transformer rating of this 18-pulse AC-DC converter.

The mathematical analysis of the different converters gives the following power rating^[11]:

The rating of the full-wave double star connection converter (without interphase reactor) is 154%.

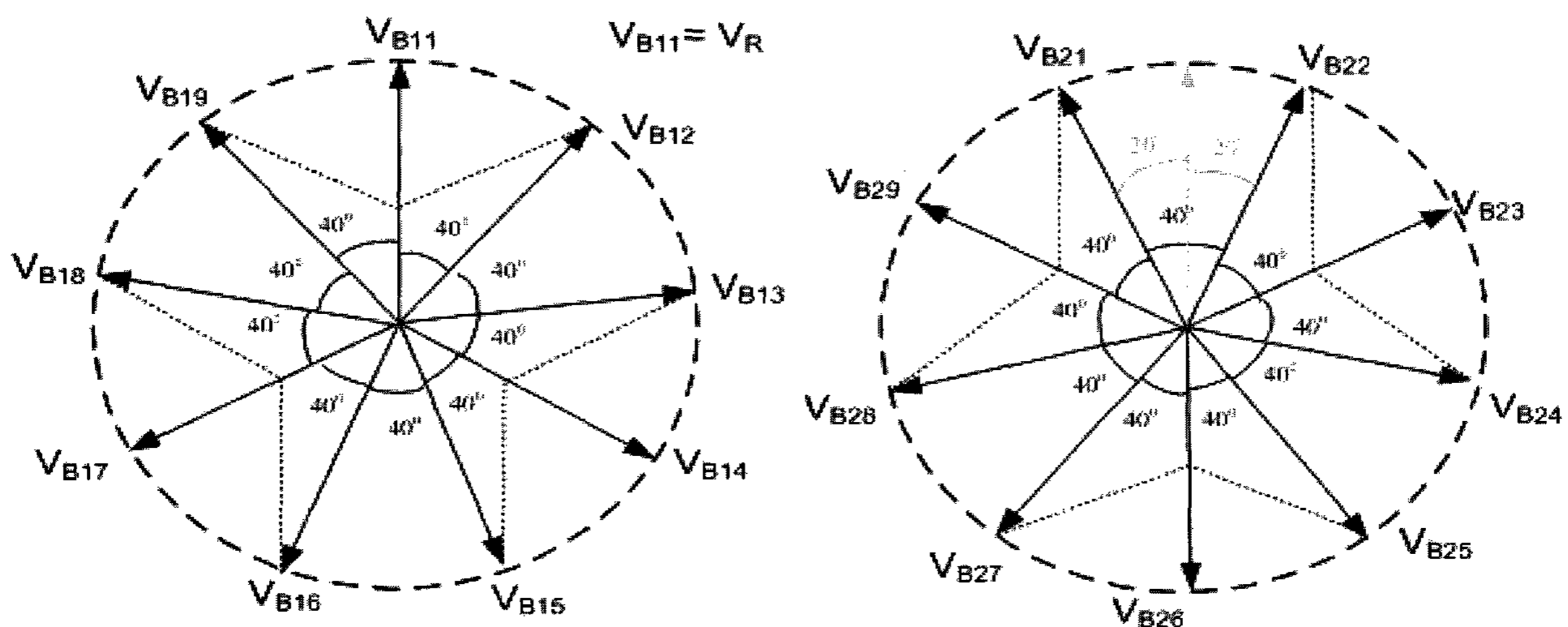

Fig. 4b Graphical representation of delta/double fork transformer secondary windings for 18-pulse AC-DC converter and phasor diagram

The rating of the ANSI 45, 6-Pulse converter connection is 126.5%.

The rating of the ANSI 45 and 46, 12-pulse combination converter is 126.5%.

The rating of the Zigzag 12 pulse AC-DC converter is 133%.

The power rating of the proposed transformer can be estimated by referring to Fig. 4 as follows:

Let us assume that the secondary output phase voltage of each group in Fig. 4 is V_R .

Then the peak voltage of the rectified sine wave is: $\sqrt{2} V_R \sin 80^\circ = 1.393 V_R$ (It is the peak of the sine wave segment that is the average of two full-wave rectified output ripples of 40° each).

The output voltage at no load,

$$V_{DC0} = (1.393 V_R) \frac{1}{(20^\circ \pi / 180^\circ)} \int_{80^\circ}^{100^\circ} \sin(\omega t) d(\omega t) = 1.385 V_R \quad (9)$$

Each diode in the 18-pulse AC-DC converter conducts for 40° in sequential manner. Therefore, the windings of the transformer in Fig. 4a corresponding to segment lengths K_2 and K_3 have diode current flowing through them which is due to conduction as well as induction. However, the current through the K_1 length winding is flowing for 120° as it carries current due to induction only. When these currents are transformed to the primary side, their value will change in the primary to secondary winding voltage ratio. These transformed currents are shown in Fig. 5b. These currents, when added, become the primary winding current which is shown in Fig. 5c. The difference of the two delta winding currents is the AC mains input current that is shown in Fig. 5d. The AC mains current has 18 steps and their values are indicated in the Fig. 5, which helps in determining its r.m.s. value.

The average current per diode is $(I_{dc}/18)$ (assuming a rectangular current waveform).

So, the peak diode current is $I_{dc}/2$.

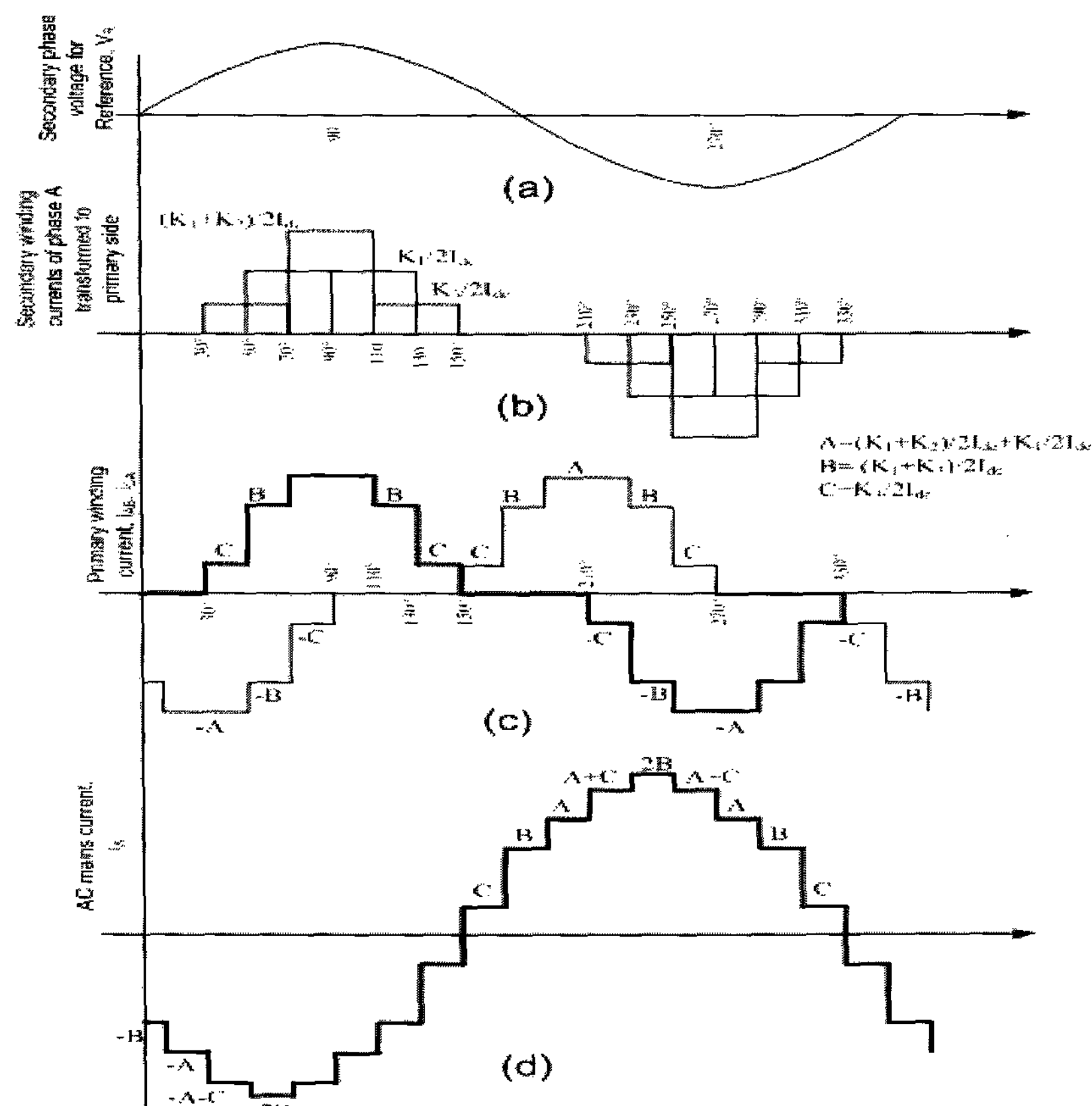

Fig. 5 The ideal values of primary winding current (i_{AC}) and input AC mains current (i_A) in proposed 18-pulse full-wave AC-DC converter

Therefore, the rms current per diode = $(I_{dc}/6) = 0.1667 I_{dc}$

$$\begin{aligned} V_A \text{ (secondary)} &= 2 \times 3 [(K_1 \cdot V_R) \cdot (I_{dc}/\sqrt{6}) + (K_2 \cdot V_R) \cdot (I_{dc}/6) + 2 \cdot (K_3 \cdot V_R) \cdot (I_{dc}/6)] \\ &= 3.05676 V_{DC0} I_{dc} = 2.207 V_{DC0} I_{dc} \end{aligned} \quad (10)$$

Let us assume that the ratio $V_{AC}=V_R$ be 1:1 for simplicity.

The primary current waveform is a stepped waveform (Fig. 5c) and the r.m.s. value of the current in the primary winding is determined to be equal to:

$$\begin{aligned} I_{CA} &= \sqrt{(I_{dc}/2)^2 \left(K_1^2 \frac{40^\circ}{180^\circ} + (K_1 + K_2)^2 \frac{40^\circ}{180^\circ} + (K_1 + K_2 + K_3)^2 \frac{40^\circ}{180^\circ} \right)} \\ &= 0.4825 I_{dc} \end{aligned} \quad (11)$$

The ideal input current waveform that is determined by the two primary winding currents (Fig. 5c) is also drawn in Fig. 5d.

$$V_A \text{ (primary)} = 3 (V_{CA} \cdot I_{CA}) = 1.045 V_{DC0} I_{dc} \quad (12)$$

Therefore, the transformer VA rating becomes = $1.626 V_{DC0} I_{dc} = 162.6\%$ of DC output power.

3. Matlab based simulation

The proposed 18-pulse AC-DC converter is simulated in the MATLAB environment along with the SIMULINK and Power System Blockset (PSB) toolboxes. The 18-pulse AC-DC converter system is fed from a 4160V, 50Hz AC supply. The DC load connected to the converter is 62V, 40kA. The value of the source impedance used for the simulations is 3%. Fig. 6(a) shows the MATLAB model of the 18-pulse full-wave AC-DC converter to improve various power-quality indices and Fig. 6(b) shows the model of the transformer winding arrangement used. The simulations of the 6-pulse and 12-pulse full-wave AC-DC converters are also carried out in MATLAB for the same supply and load conditions for comparison with the proposed topology. The results of the 6-pulse, 12-pulse and proposed 18-pulse full-wave AC-DC converters are given in Table 2 and the waveforms are shown in Figs. 7-13.

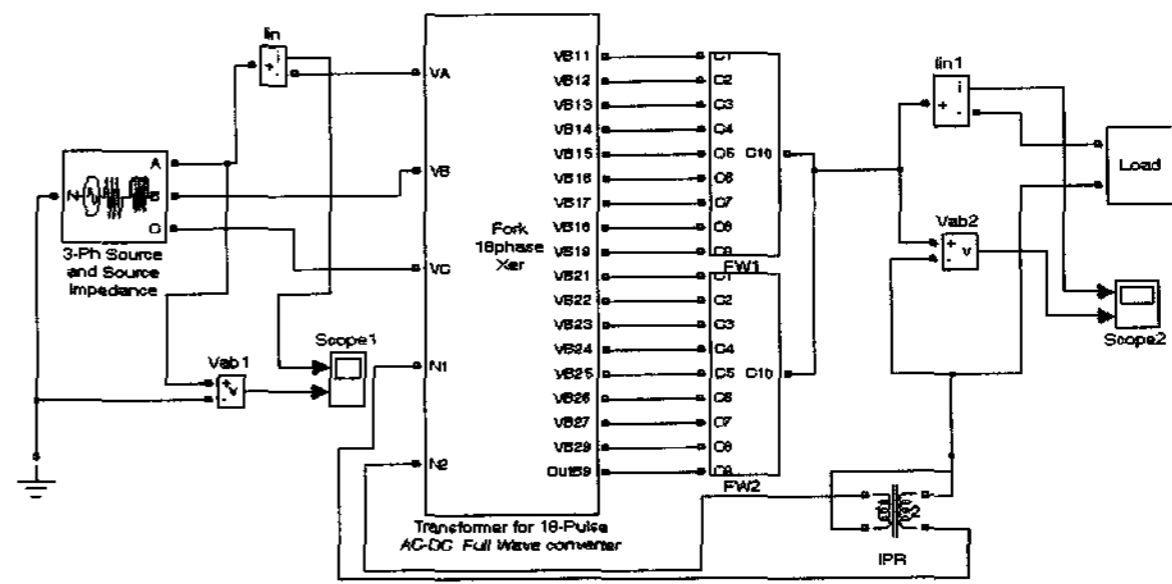

Fig. 6(a) MATLAB model of the 18-pulse full-wave AC-DC converter

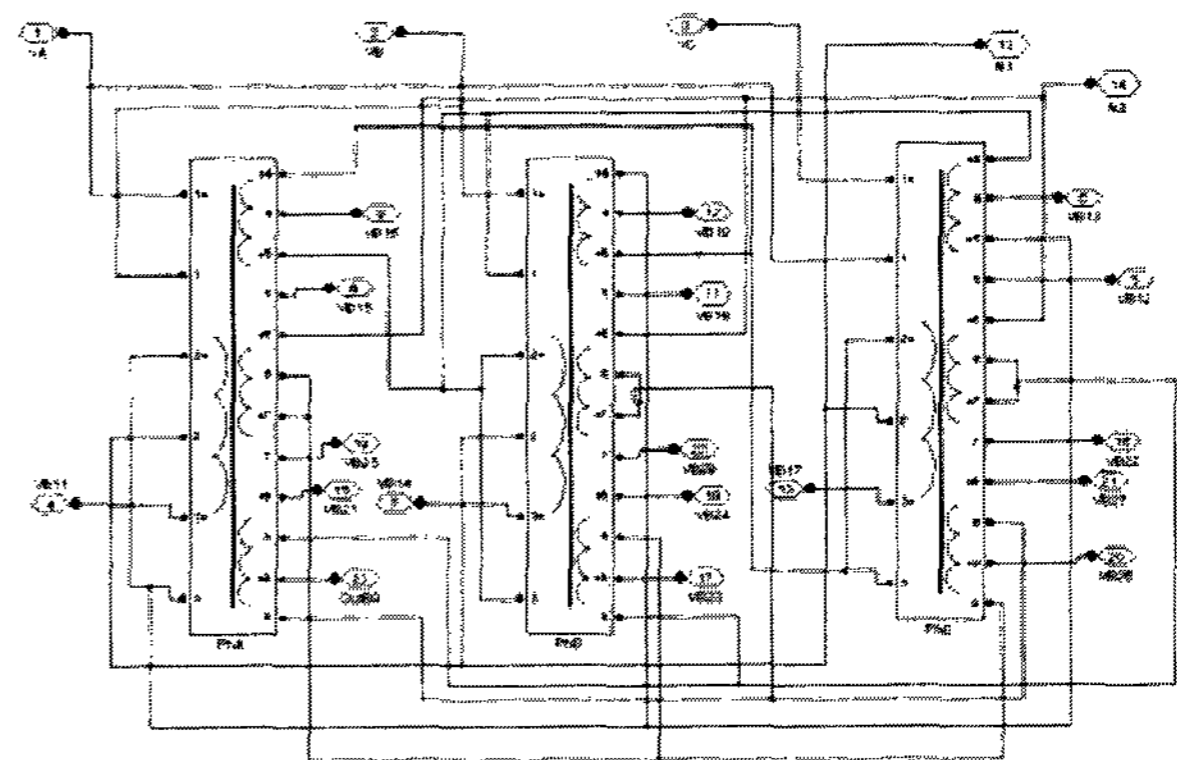

Fig. 6(b) MATLAB model of the proposed transformer for 18-pulse full-wave AC-DC converter

4. Experimentation

A small rating prototype of the proposed AC-DC converter is developed in the laboratory for 6kW, 150V DC load. The 18-pulse AC-DC converter is realized by three single-phase transformers and the design details are as follows.

Flux Density: 0.8Tesla, Current Density: 2.3A/mm²,

Turns per volt: 0.88

E-Laminations: Length=23.5cm, Width=16cm

I-Laminations: Length=23.5cm, Width= 4cm

Effective Area of cross-section of core=58cm² (7.6 cm X 8.6cm)

Autotransformer winding details-

Winding Voltage	Number of turns	Gauge of wire (SWG)
V_{AC}	365	17
$K_1 \cdot V_R$	40	15
$K_2 \cdot V_R$	61	17
$K_3 \cdot V_R$	74.5	17

The results are recorded using the ‘Fluke 43B’ Power Quality Analyzer and the power quality indices so obtained are tabulated in Table 3. The recorded waveforms for light load and full-load are shown in Fig. 14.

5. Results and discussion

The power quality indices obtained from simulations of the 6-pulse, 12-pulse and the proposed 18-pulse AC-DC converters are given in Table 2. The various waveforms of the 18-pulse converter transformer are shown in Fig. 7 at light load to make the steps visible. It can be seen that the input current (i_A) has 18 steps in one cycle of AC supply. Two primary winding currents i_{AB} and i_{CA} are shown whose algebraic sum is the supply current (i_A). Moreover, there are the secondary winding currents (i_{K1} , i_{K2} , i_{B15} and i_{B16} , where i_{B15} means the current in the transformer winding connected at B15) which results in i_{dc1} . The current i_{dc} is the sum of two full-wave converter output currents (i_{dc1} and i_{dc2}) shown along with the output DC voltage, V_{dc} .

Fig. 8 (a) shows the input and output current and voltage waveforms of the full-wave 6-pulse AC-DC

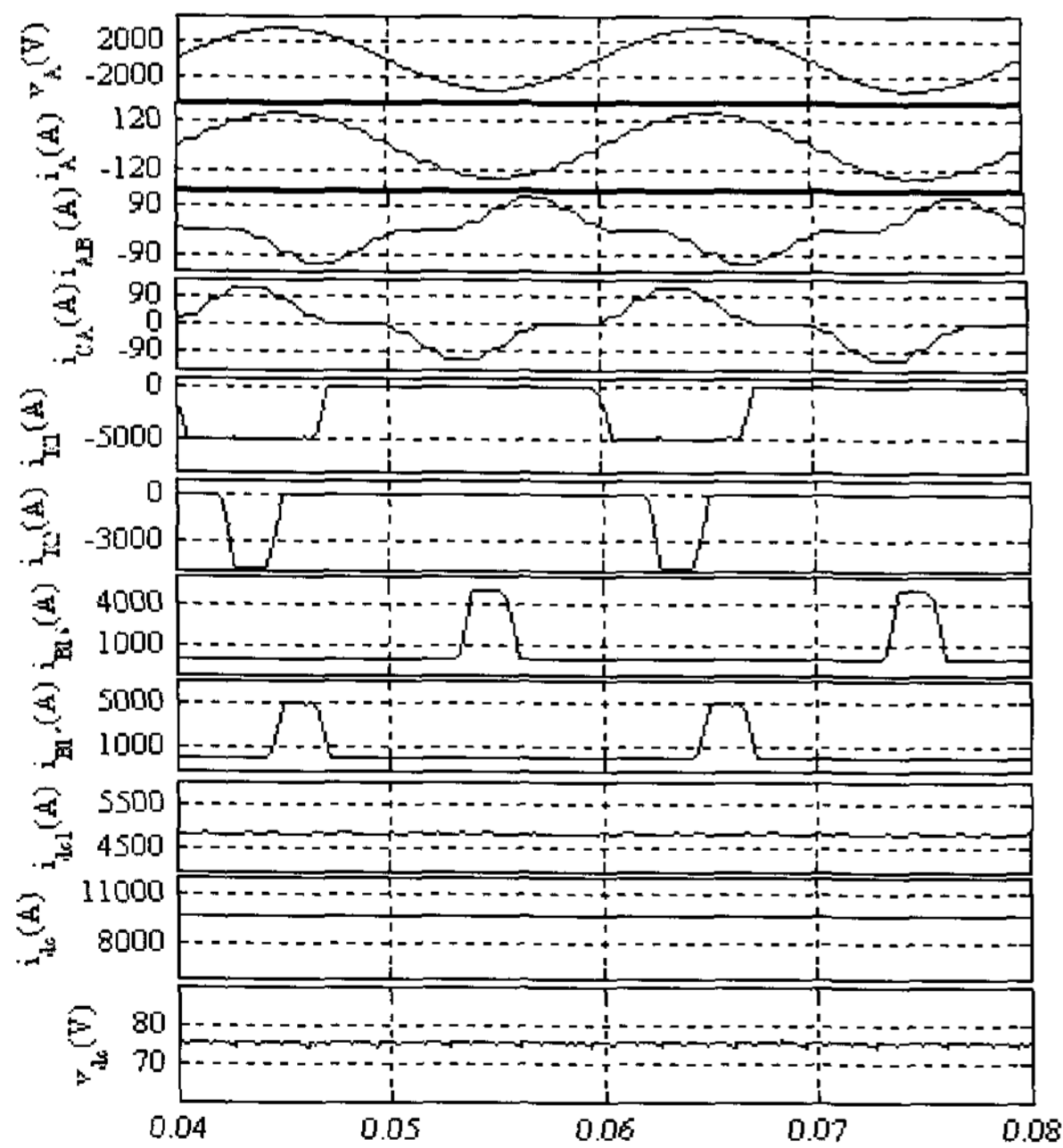
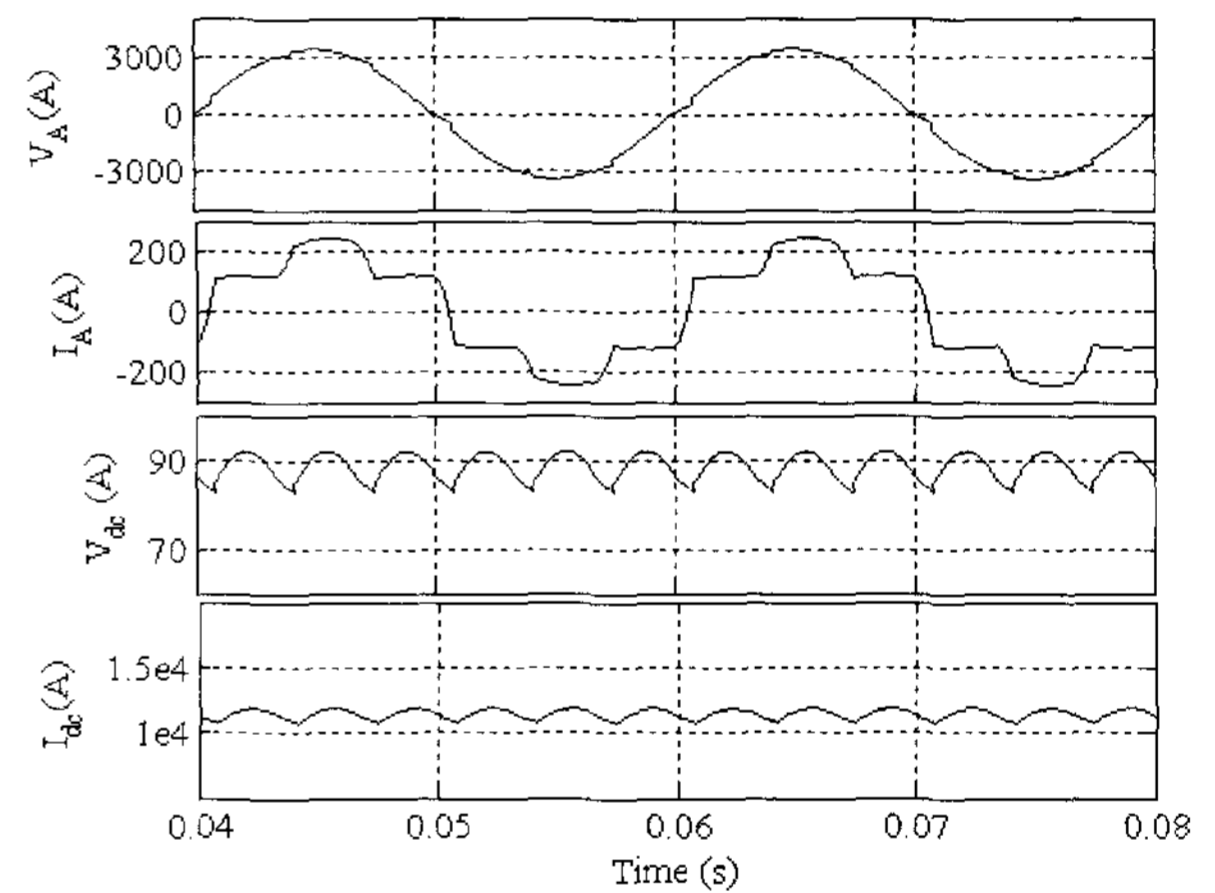

Fig. 7 Instantaneous values of input phase voltage (V_A), input AC mains current (i_A), primary winding currents (i_{AB} and i_{CA}), winding-currents of secondary (i_{K1} , i_{K2} , i_{B15} , i_{B16}), a bridge output current (i_{dc1}) and output DC current (i_{dc}) and voltage (V_{dc}) waveform of 18-pulse full-wave AC-DC converter at light-load

converter at light load (20% of full-load). The current waveform of the AC mains, its harmonic spectrum and the THD of the six-pulse AC-DC converter at light load are shown in Fig. 8(b). The waveforms and the input current harmonic spectrum at full load for the 6-pulse AC-DC converter are shown in Figs. 9(a) and 9(b), respectively. The THD_i is of the order of 18.51% at full-load which is not acceptable as per IEEE-519 Standard requirements.

Fig. 10(a) shows the input AC phase voltage V_A , input AC current i_A , output DC voltage V_{dc} , and load current i_{dc} waveforms of the 12-pulse AC-DC converter at light load. Fig. 10(b) shows the AC mains current waveform i_A and its harmonic spectrum. The harmonic spectrum clearly shows that the 11th and 13th are the dominant harmonics and the THD_i of the AC mains current (THD_i) is 10.05% at light load. Fig. 11 shows the performance of the 12-pulse



(a) Input and output voltage and current waveform

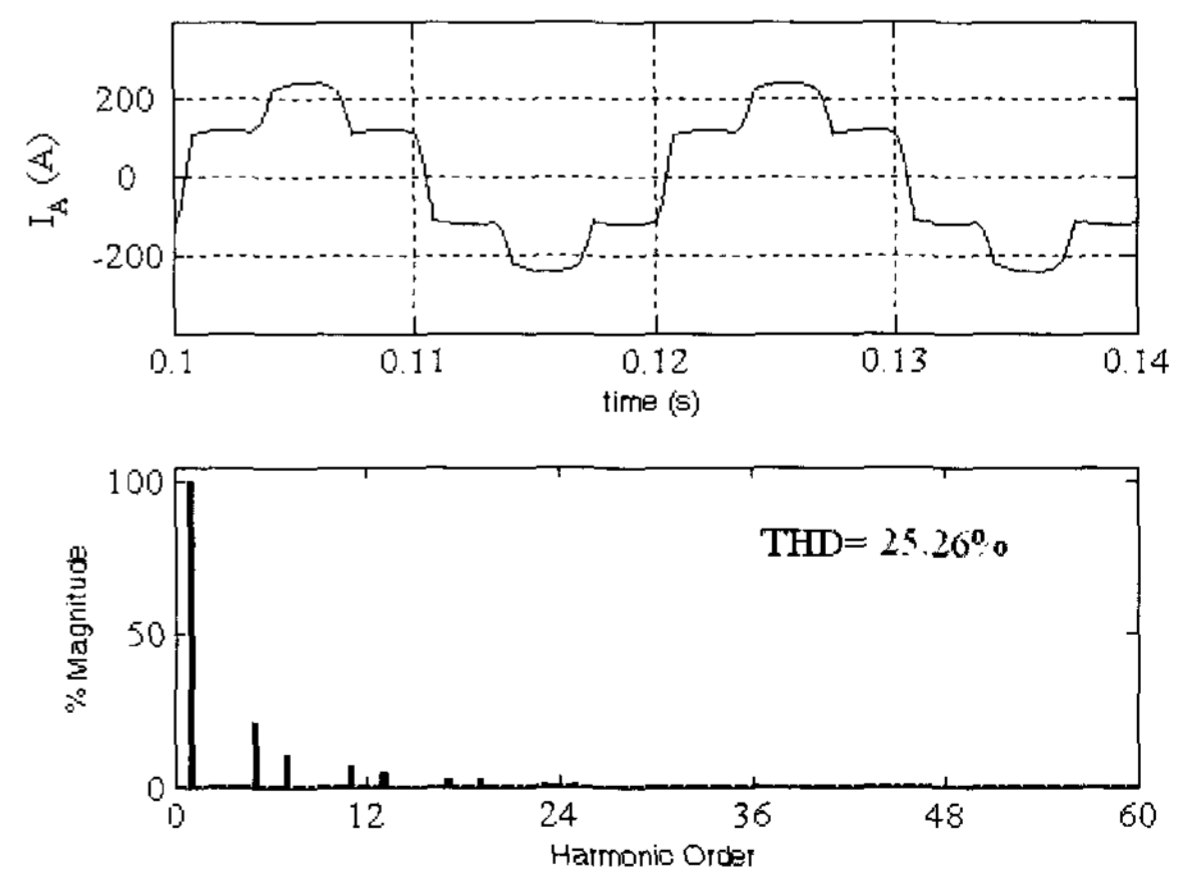

(b) Input current waveform and its harmonic spectrum

Fig. 8 Six-pulse full-wave AC-DC converter at light load

Table 2 Comparison of power quality parameters of the load fed from different AC-DC converters at various loads

Sr. No.	Topo-logy	% Load	%THD of V_A	AC Mains Current I_A (A)	% THD of I_A	Distortion Factor	Displace-ment Factor	Power Factor	DC Voltage (V_{dc})	Load Current I_{dc} (kA)	Ripple Factor %
1	6-pulse	20	2.664	163.3	25.26	0.9693	0.9893	0.9589	88.54	11.41	3.238
		100	5.562	559.2	18.51	0.9877	0.9771	0.9591	62.24	40.13	1.596
2	12-pulse	20	1.629	130.1	10.01	0.9948	0.9922	0.9871	81.36	10.50	1.128
		100	3.011	490.1	5.175	0.9983	0.9816	0.9799	62.09	40.03	2.032
3	18-pulse	20	0.713	109.8	3.785	0.9993	0.9978	0.9971	75.08	10.30	0.318
		100	0.417	442.7	1.270	1.0000	0.9959	0.9959	62.28	40.15	0.800

AC-DC converter at full-load. The THD of the AC current at full-load is observed to be 5.175%. The value of the AC mains current THD is found to be less than that of the 6-pulse AC-DC converter.

Fig. 12(a) shows the input AC phase voltage V_A , input

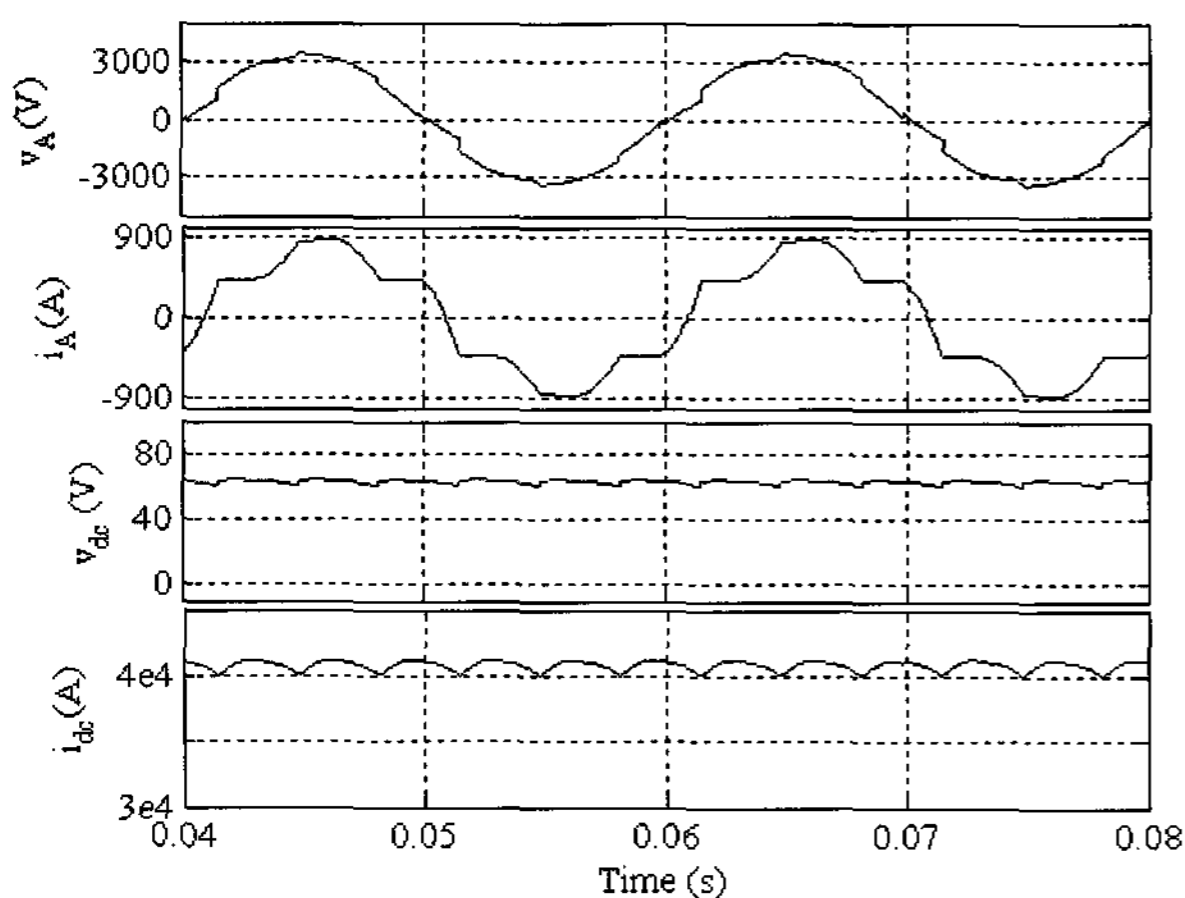

(a) Input and output voltage and current waveform

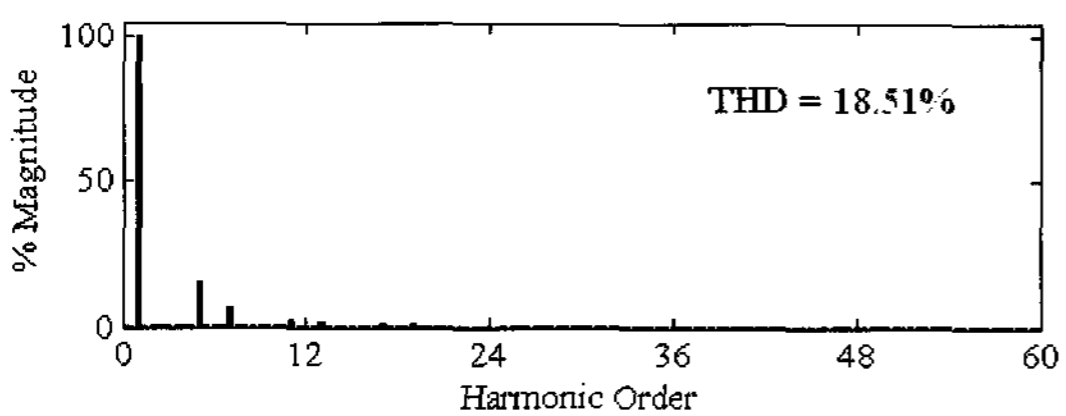
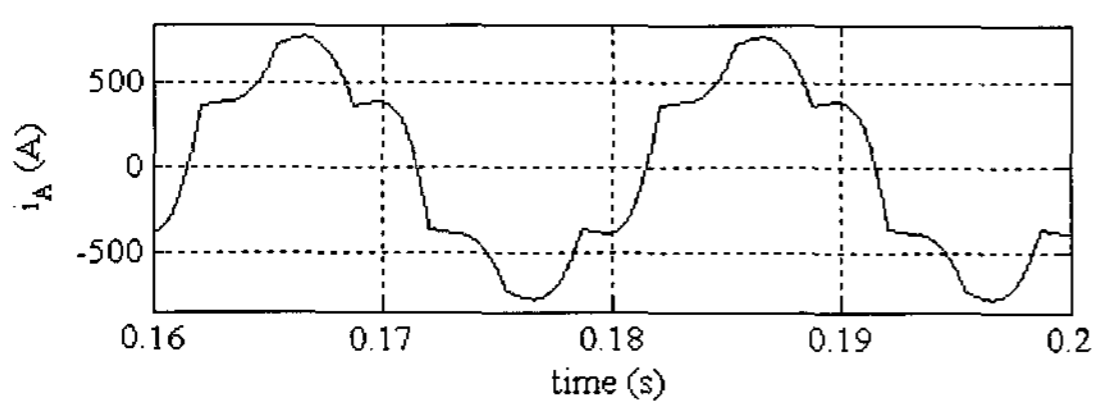

(b) Input current waveform and its harmonic spectrum

Fig. 9 Six-pulse full-wave AC-DC converter at full-load

AC current i_A , output DC voltage V_{dc} , and load current i_{dc} waveforms of the proposed 18-pulse AC-DC converter at light load. Fig. 12(b) shows the AC mains current waveform i_A and its harmonic spectrum. The harmonic spectrum clearly shows that the 17th and 19th are the dominant harmonics and the THD of the AC mains current (THD_i) is 3.785% at light-load. Fig. 13 shows the performance of the 18-pulse AC-DC converter at full-load. The THD of the AC current at full-load is observed to be 1.27%. The value of the AC mains current THD is found to be lower than that of the 6-pulse and 12-pulse converter input currents and meets IEEE-519 Standard requirements.

The improvement in power quality indices such as total harmonic distortion of the supply current (THD_i), total harmonic distortion of the supply voltage (THD_v), distortion factor (DF), and power factor (PF) at different loads can be seen in Table 2. It can be seen that the THD of the input AC current of the proposed 18-pulse full-wave AC-DC converter system is around 5% at varying loads and its waveform is close to sinusoidal. The power factor is observed to be of the order 0.99 at varying loads in the proposed 18-pulse AC-DC converter as given in Table 2. Moreover, Table 2 reveals that the voltage distortion at the point of common coupling (PCC) is negligible as THD_v remains less than 1%. Further, the input current has been reduced by about 20% in the proposed configuration compared to the 6-pulse Full-wave AC-DC converter. The mathematical analysis (section 2.2) shows that the rating of the transformer is 162.6% which is of the order of other full-wave AC-DC converter transformers but the power quality at its input is well within the IEEE-519 Standard limits.

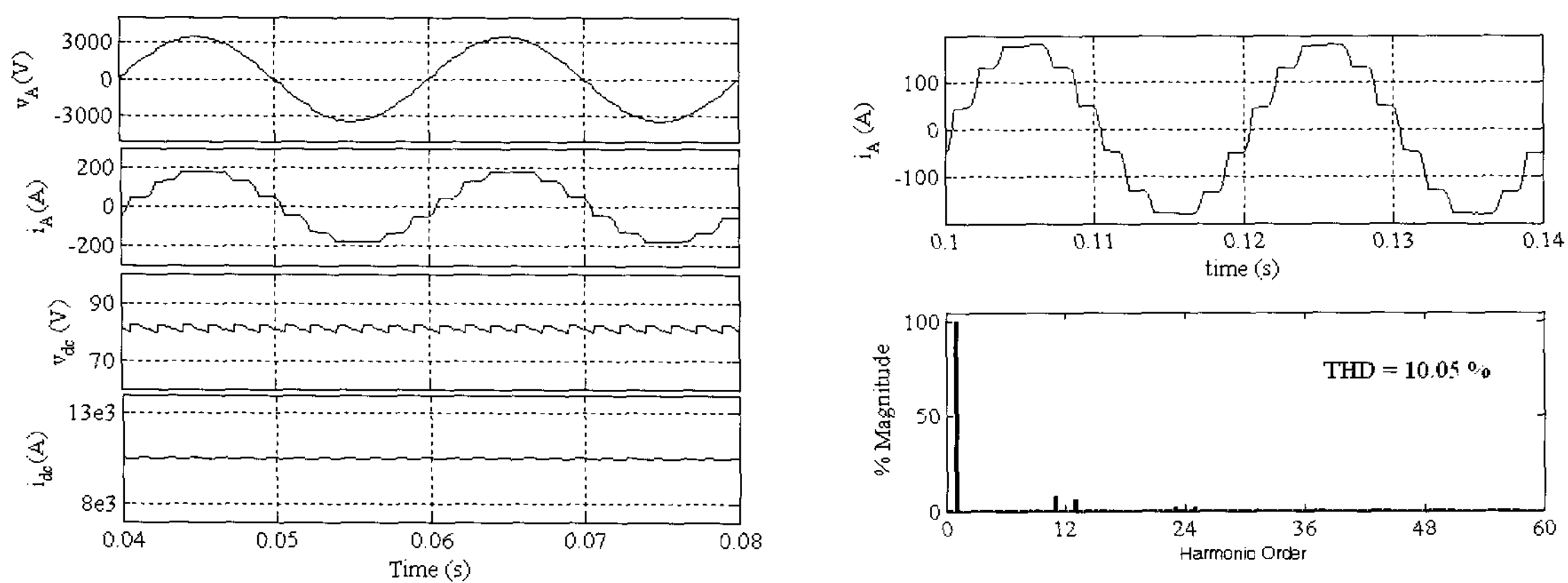

(a) Input and output voltage and current waveform

(b) Input current waveform and its harmonic spectrum

Fig. 10 Twelve-pulse full-wave AC-DC converter at light-load

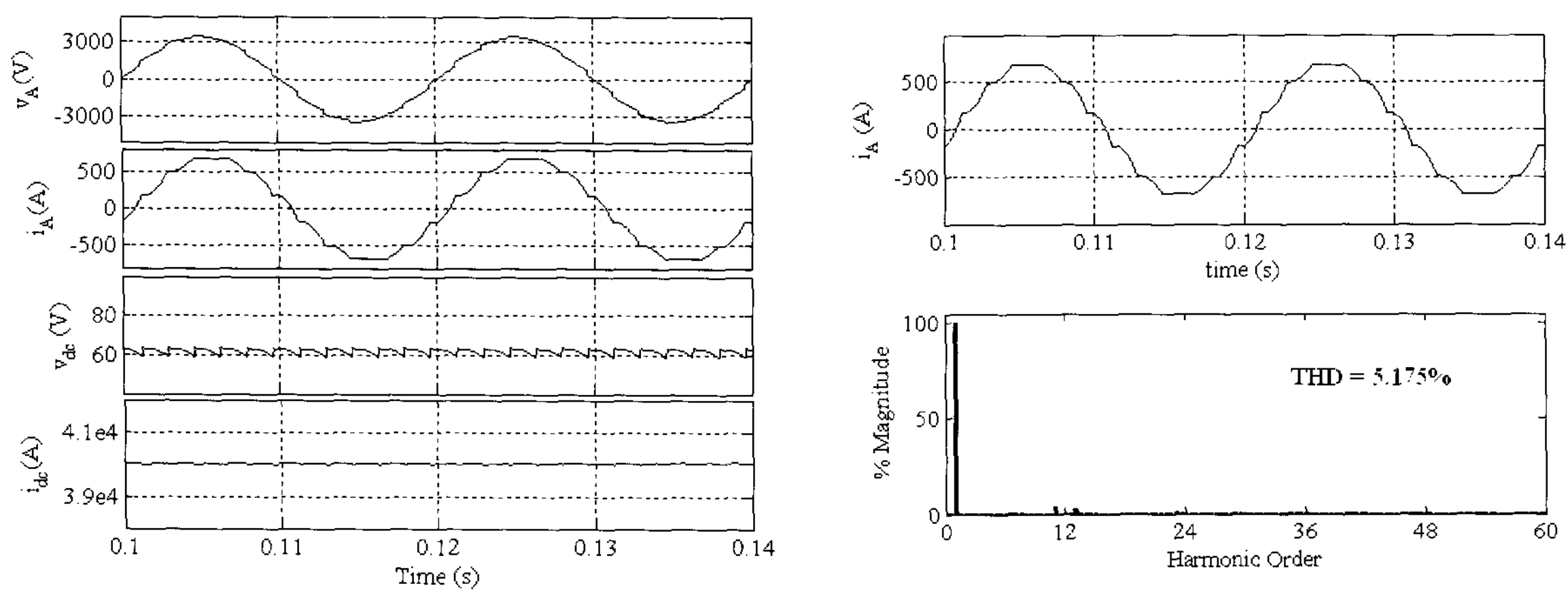

(a) Input and output voltage and current waveform

(b) Input current waveform and its harmonic spectrum

Fig. 11 Twelve-pulse full-wave AC-DC converter at full-load

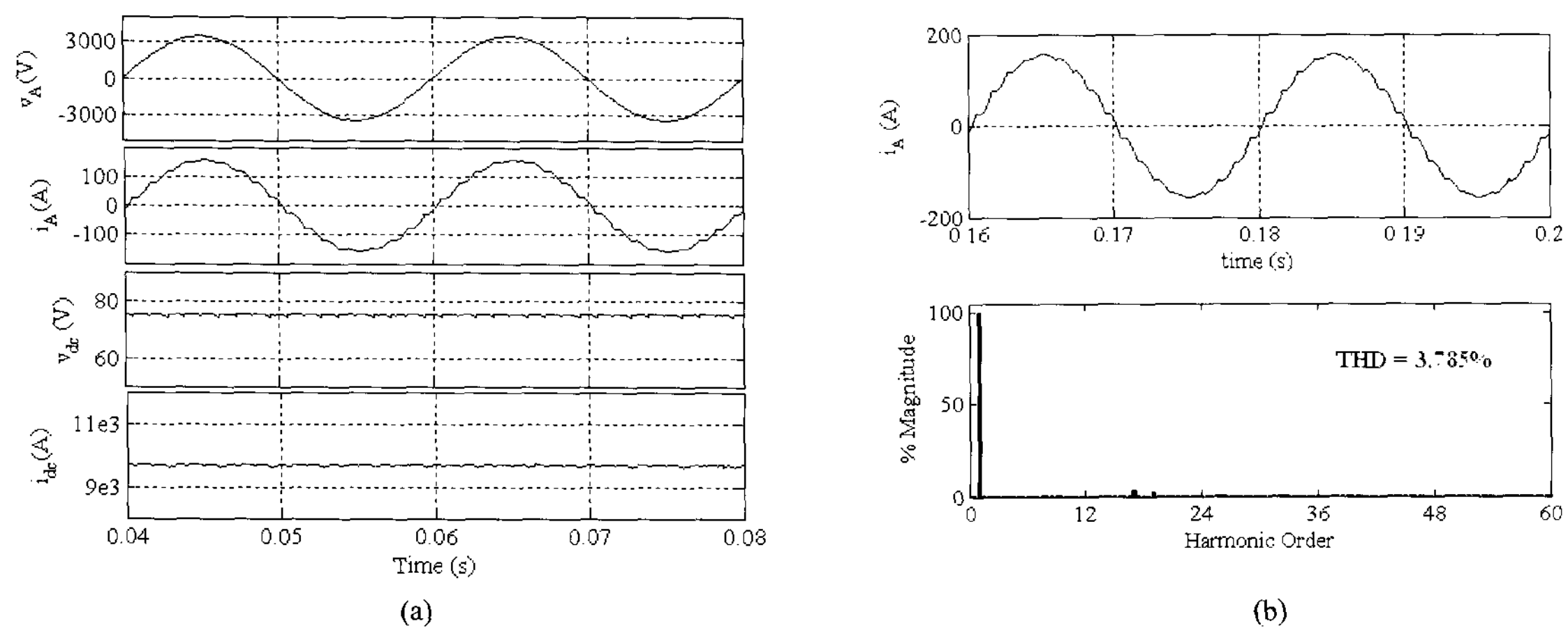
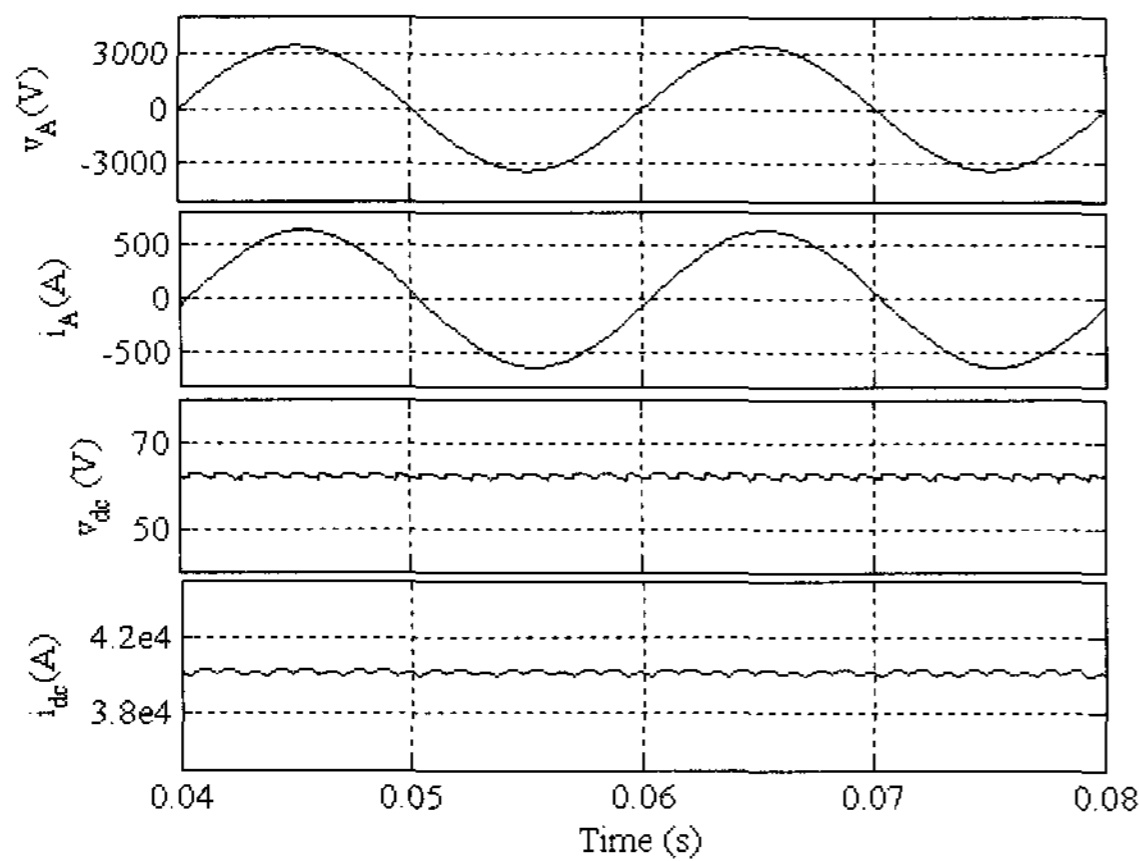
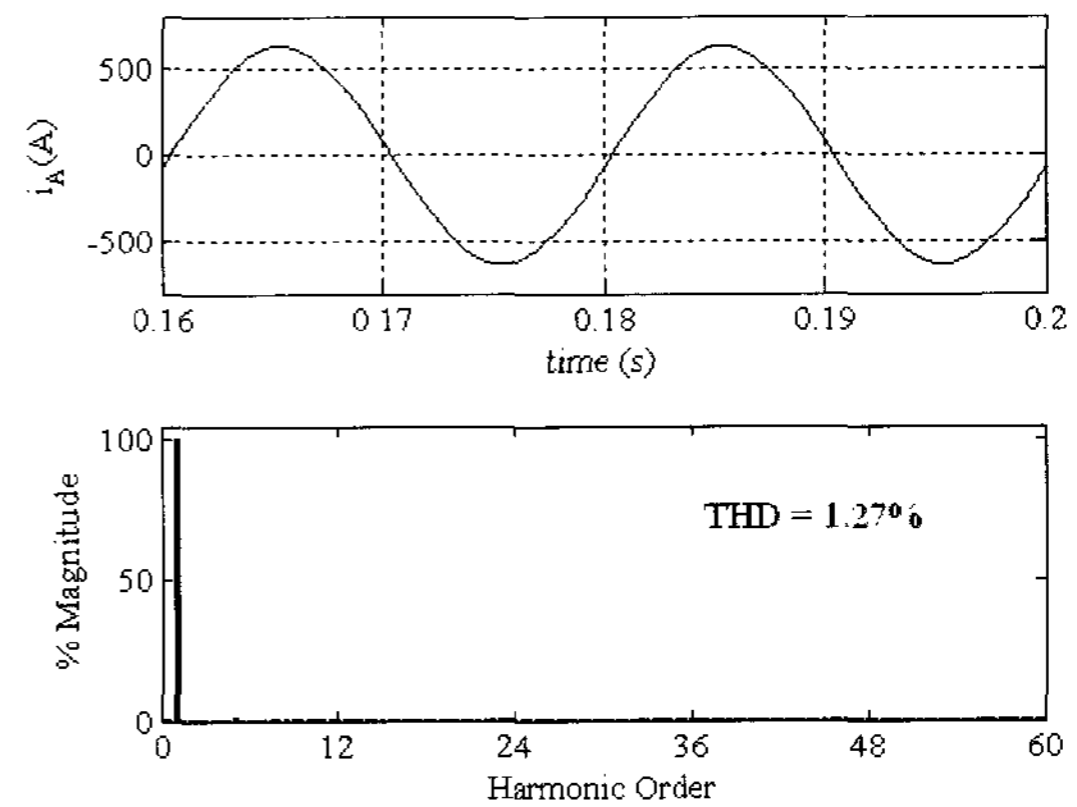

Fig. 12 Eighteen-pulse full-wave AC-DC converter at light-load - (a) Input and output voltage and current waveform (b) Input current waveform and its harmonic spectrum



(a) Input and output voltage and current waveform



(b) Input current waveform and its harmonic spectrum

Fig. 13 Eighteen-pulse full-wave AC-DC converter at full-load

The experimental results of the proposed 18-Pulse AC-DC converter at varying loads are shown in Table 3. It shows that the THD of the input current varies from 3.6% to 5.4% when the load is reduced from full-load to light load (20% load). The displacement factor and power factor also show similar trend and values. Fig. 14a clearly shows dominant 17th and 19th order harmonics in the AC mains current and marks the 18-pulse converter behavior. The harmonic spectrum and THD_i at full-load is shown in Fig. 14b. THD is even less than 5% implying that the most stringent requirement of power quality is met without using any filter at the input and the output voltage ripples are also reduced. The number of diodes required is eighteen but the tuned low pass filters are eliminated and the transformer derating due to harmonics current flowing in it is minimized.

6. Conclusions

The delta/double-fork transformer used for an 18-pulse AC-DC converter system has a single primary and needs only one interphase reactor. Simulation and test results have demonstrated the improved power quality of the proposed 18-pulse full-wave AC-DC converter. The resulting system has exhibited a high level performance with clean power characteristics to be used for high current applications. The total harmonic distortion of the

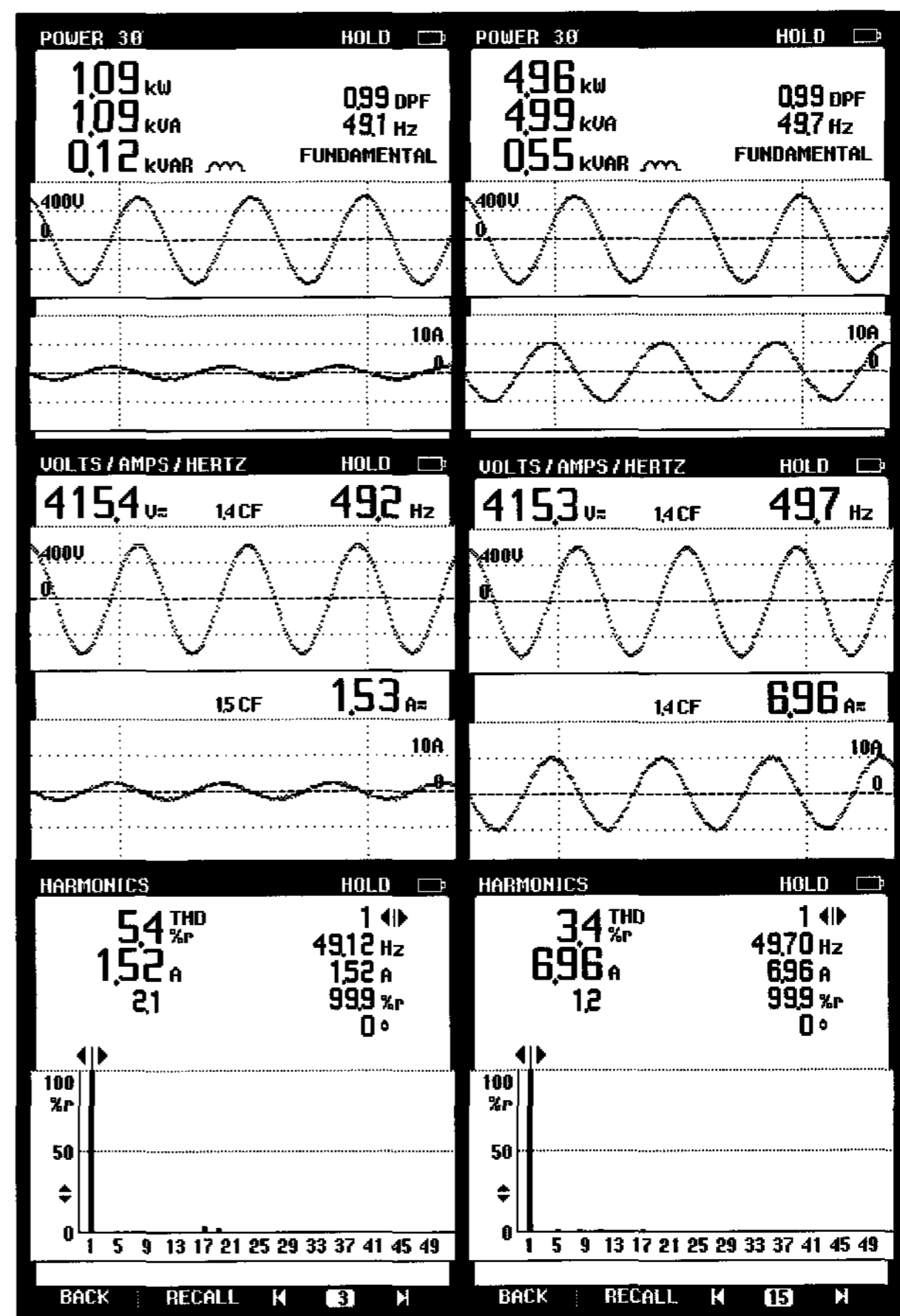

(a) At light-load

(b) At full-load

Fig. 14 Test result showing input current waveform, power, and harmonic spectrum for full-wave 18-pulse AC-DC converter

Table 3 Test Results of Proposed AC-DC converters at varying loads

Sr. No.	Input Power, kW	%THD of V_A	AC Mains Current I_A (A)	% THD of I_A	Crest Factor	Displacement Factor	Power Factor	DC Voltage (V_{dc})	Load Current I_{dc} (A)
1	1.09	0.9	1.53	5.4	1.5	0.99	0.9939	152.4	7.08
2	1.58	0.9	1.99	4.7	1.4	1.00	0.9944	150.2	10.39
3	2.05	0.9	2.59	4.4	1.4	1.00	0.9953	147.7	13.62
4	2.51	0.9	3.53	4.2	1.4	1.00	0.9950	146.4	15.96
5	3.05	0.9	4.28	3.7	1.4	1.00	0.9952	144.4	19.20
6	3.51	0.9	4.96	3.4	1.4	1.00	0.9950	142.5	21.69
7	4.02	1.0	5.63	3.5	1.4	1.00	0.9950	140.6	24.38
8	4.49	0.9	6.28	3.2	1.4	0.99	0.9938	138.5	26.63
9	4.96	1.1	6.96	3.4	1.4	0.99	0.9939	136.0	28.46
10	5.47	1.1	7.67	3.3	1.4	0.99	0.9938	133.7	31.11
11	5.96	1.1	8.4	3.6	1.4	0.99	0.9909	131.5	34.17

input current is observed to be much less than 8% at varying loads meeting the IEEE-519 standard requirement. The output voltage ripple is reduced to the order of less than 0.4% and the input power factor is improved at varying loads thereby improving efficiency of the system. Test results have validated the model and design of the proposed 18-pulse AC-DC converter system.

References

- [1] R. Wells, "Static Power Converters", Robert Cunningham and Sons Ltd., Scotland, Great Britain, 1962.
- [2] IEEE Standard 519-1992, IEEE Recommended Practices and Requirements for Harmonic Control in Electrical Power Systems, IEEE Inc., New York, 1992.
- [3] R. Fuentes, J. Quezada and I. Saavedra, "Harmonics Losses Measurement at Rated Current and rated Voltage in 12-Pulses High Current Controlled Transformer-Rectifiers", in Proc. Ninth IEEE Int. Conf. On Harmonics and Quality of Power, Vol. 3, pp. 1065-11072, 2000.
- [4] R. Fuentes and L. Ternicien, "Harmonics Mitigation in High Current Multipulse controlled transformer Rectifiers", in Proc. Tenth IEEE Int. Conf. On Harmonics and Quality of Power, Vol. 1, pp. 189-195, 2002.
- [5] A. J. Maslin, Sharon, G. F. Jones and Irwin "Electrical Induction Apparatus", US Patent 2,307,527, Jan., 1943.
- [6] R. R. Brown, "Rectifier and DC Bus System Design for the Copper Electrowinning Industry", IEEE Trans. on Ind. Appl., vol. 26, no. 6, pp. 1116-1119, Nov./Dec., 1990.
- [7] E.P. Wiechmann, R. P. Burgos and J. Holtz, "Sequential Connection and Phase Control of a High-Current Rectifier Optimized for Copper Electrowinning Applications", IEEE Trans. on Ind. Elect., Vol.47, No. 4, pp.734-743, 2000.
- [8] G. Oliver, G. E. April, E. Ngandui and C. Guimaraes, "Novel Transformer Connection to Improve Current Sharing in High-Current DC Rectifiers", IEEE Trans. on Ind. Appl., Vol. 31, No. 1, pp. 127-133, Jan./Feb. 1995.
- [9] Shota Miyairi, Shoji Iida, Kiyoshi Nakata and Shigeo Masubawa, "New method for reducing harmonics involved in input and output of rectifier with interphase transformer", IEEE Trans. on Ind. Appl., Vol. 22 No. 5, pp. 790-797, Sep.- Oct. 1986.
- [10] E.P. Wiechmann and P. E. Aqueveque, "Filterless high current rectifier for electrolytic applications", in Proc. of IEEE conf. IAS 2005, Vol.1, pp.198-203, 2-6 Oct. 2005.
- [11] R. W. Lye (Editor), Power Converter Hand Book-Theory, Design, Applications, Power Delivery Department, GE Canada, Ontario, March 1990.



Bhim Singh was born in Rahamapur, U. P., India in 1956. He received his B. E. (Electrical) degree from the University of Roorkee, India in 1977 and his M. Tech. and Ph. D. degrees from the Indian Institute of Technology (IIT), New-Delhi, in 1979 and 1983, respectively. In 1983, he joined as a Lecturer and in 1988 became a Reader in the Department of Electrical Engineering, University of Roorkee. In December 1990, he joined as an Assistant Professor, became an Associate Professor in 1994 and full Professor in 1997 at the Department of Electrical Engineering, IIT Delhi. His fields of interest include power electronics, electrical machines and drives, active filters, static VAR compensators, power quality, FACTS, and HVDC systems.

Prof. Singh is a Fellow of the Indian National Academy of Engineering (INAE), the Institution of Engineers (India) (IE (I)) and the Institution of Electronics and Telecommunication Engineers (IETE), a Life Member of the Indian Society for Technical Education (ISTE), the System Society of India (SSI) and the National Institution of Quality and Reliability (NIQR) and a Senior Member of IEEE (Institute of Electrical and Electronics Engineers).



Sanjay Gairola was born in Chandigarh, India in 1968. He received his B.E. degree in Electrical Engineering from Motilal Nehru National Institute of Technology, Allahabad in 1991 and his M. Tech. degree from Indian Institute of Technology (IIT), New Delhi, in 2001. He joined as a lecturer in the Department of Electrical Engineering, Krishna Institute of Engineering and Technology, Ghaziabad, U.P., India in 1997 and became Assistant Professor in January 2004. At present he is working in Galgotias College of Engineering and Technology, Greater Noida, U.P., India. He is a Life Member of the Indian Society for Technical Education (ISTE). Presently, he is also a research scholar in the Department of Electrical Engineering, IIT Delhi, pursuing his Ph.D. degree. His fields of interest include power quality, power electronics, electric machines and drives.