

# EVALUATION OF TIGHTNESS OF PROXIMAL TOOTH CONTACT IN PERMANENT DENTITION

Kyung-Hwa Kim<sup>1</sup>, DDS, MSD, Jae-Hyun Jung<sup>1</sup>, DDS, MSD,

Hee-Jung Kim<sup>2</sup>, DDS, MSD, PhD, Chae-Heon Chung<sup>3</sup>, DDS, MSD, PhD, Sang-Ho Oh<sup>2\*</sup>, DDS, PhD

<sup>1</sup>Graduate Student, Department of Prosthodontics, School of Dentistry, Chosun University,

<sup>2</sup>Assistant Professor, Department of Prosthodontics, School of Dentistry, Chosun University

<sup>3</sup>Professor, Department of Prosthodontics, School of Dentistry, Chosun University

## INTRODUCTION

Under physiological conditions, teeth are stabilized in the dental arch by making occlusal contacts with opposing teeth and proximal contacts with adjacent teeth.<sup>1</sup> Interproximal contact has been defined as the area of a tooth that is in close association, connection or touch with an adjacent tooth in the same arch.<sup>2</sup> The proper proximal contact plays an important role in the stability and maintenance of the integrity of the dental arches.<sup>3</sup> However, a weak or slightly open proximal tooth contact would permit food impaction and cause subsequent dental caries, halitosis, periodontal disease, or drifting of teeth. On the other hand, excessive proximal tooth contact would result in wedging of teeth and undesirable tooth movement and trauma of periodontium.<sup>4-9</sup> Therefore, it is important to maintain proper proximal tooth contact.

Alexander *et al.*<sup>10</sup> reported that the proximal contact is maintained by the next two conflictive theories.: The first theory, compression theory, is that the compression force occurs between proximal surfaces of the adjacent teeth and keeps an active proximal contact. The second theory, resistance theory, is that teeth touch each other passively in a non-force mode, but resisting any force which tries to separate them.

Tightness of proximal tooth contact (TPTC) is conventionally checked with dental floss.<sup>11,12</sup> It is considered that such a contact allow floss to pass with a snap.<sup>13</sup> Although this method is simple and easy, it is inaccurate to

record slight change of TPTC.<sup>14</sup> If the assessment is performed using a thin metal strip, more reliable information about the contact state may be acquired.<sup>15,16</sup> Osborn<sup>17</sup> was the first who constructed a device based on the theory of frictional force to quantify the TPTC by inserting a thin metal strip interdentially which is pulled out with a spring balance in horizontal direction. When a strip is slipped between two adjacent teeth, each tooth is displaced and exerts a force against the strip. The maximum frictional force ( $F_f$ ) that resists withdrawal is a value for the TPTC. With a known coefficient of dynamic friction ( $\mu$ ) between tooth enamel and metal strip material, TPTC is related to  $F_f$  by the following equation: Contact tightness =  $F_f/2\mu$  (N). Modifications of this device were described in several other studies.

Southard *et al.*<sup>18</sup> used a digital tension transducer to measure the frictional force occurred at pulling metal strip of 0.03 mm-thickness, whereas Oh *et al.*<sup>19</sup> constructed a device equipped with a digital strain gauge designed to convert the frictional force into compressive force using a hinge. Dörfer *et al.*<sup>20</sup> developed a device which the metal strip of 0.05 mm-thickness was fixed in a special holder, which was prepared with strain gauges to register the bending action of the holder during removal of the strip. TPTC was measured by device as stated above quantitatively, nevertheless, the data are not enough yet.

The objective of this study was to measure the TPTC of all proximal contact using a novel device in permanent dentition.

Corresponding Author: Sang-Ho Oh

Department of Prosthodontics, School of Dentistry, Chosun University

375 Seosuk-Dong, Dong-Gu, Gwangju, 501-759, Korea +82 62 220 3828: e-mail, shoh@chosun.ac.kr

Received September 16, 2008 Last Revision November 14, 2008 Accepted November 20, 2008.

※ This study was supported by research funds from Chosun University, 2008.

## MATERIALS AND METHODS

### 1. Subjects

Ten healthy young adults (5 males and 5 females) with class I normal occlusion consented to participate in the study. The mean age of the subjects was 26.1 years (range : 25 - 29 years), and informed consent was obtained from all participants. All subjects had complete dentitions from the second molars forward and the third molar did not visually existed. None of the subjects had received prosthodontic or conservative treatment of the proximal surface and orthodontic treatment during the past year. No signs or symptoms of food impaction or temporomandibular disorders were present in any of the subjects. None of the subjects had periodontal disease. At rest, contact tightness was considered appropriate if a 0.05 mm stainless steel strip (Contact gauge: GC Co., Tokyo, Japan) could be inserted with some resistance, but a 0.11 mm strip could not.<sup>21</sup>

### 2. Measuring device

The measuring device used for recording TPTC has been described previously.<sup>22</sup> Briefly, the measuring device is consisted of sensor part, motor part, body part and measuring part. Sensor part operates amplifying and filtering of the output voltage that occurred from strain gauge sensor. The output voltage of the sensor is converted into Newton (N) and it could measure up to 98 N. The motor part is the stepping motor. Each parts of this device are fixed to the body part that is consisted of duralumin alloy. For the structure of measuring part, the outer pipe (handle) and inner part was manufactured by processing duralumin pipe. On the inner pipe, steel wire from the body part and metal strip (2 mm width, 0.03 mm thickness) which was inserted to the proximal surface was fixed by the screw. Right after pushing the starting button, the metal strip was pulled by constant speed of 8 mm/s. The measuring part was equipped automatic reverting limit switch (LS) for convenience and 90 degrees curvature of the measuring part tip was manufactured for the approach to the posterior teeth (Fig. 1).

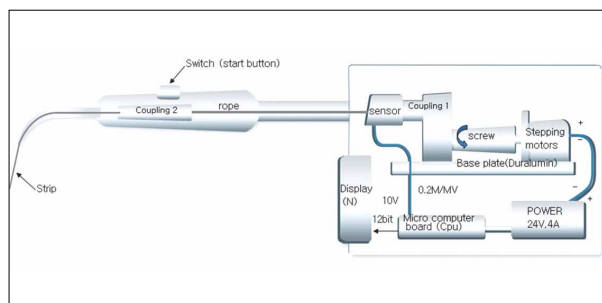

Fig. 1. Diagram of the measuring system.

### 3. Measurement of TPTC

Due to unfavorable approach of the posterior teeth in an upright posture, experiment was operated in a supine posture. Each subject was seated in a dental chair in a supine posture with head support and all muscles of the subjects were relaxed and maintained rest state. After turning on the device, zero degree was controlled. Before each test, the proximal contact areas were dried with an air syringe and the metal strip was inserted to proximal surface (Fig. 2).

As pushing the starting button, the metal strip was removed by constant speed. The highest value of the frictional force which was occurred during removal was considered the TPTC. This trial was repeated five times at same proximal contact area. Among these values, the highest and the lowest values were excluded, and then the mean value of the three measured values was determined as the representative value in each contact area. Measurement was operated at rest state and the subjects were restricted not to be occlude during measurement. Between each measurement, there was more than 2 minutes of rest



Fig. 2. Measurement of the tightness of proximal tooth contact between the left first molar and second molar in mandible.

intervals.<sup>23</sup> All experiments were conducted around 4 PM, allowing sufficient rest time after the lunchtime meal.

#### 4. Statistical analysis

The statistical evaluation of the data was performed using the software package SPSS version 12.1 (SPSS Inc., Chicago, USA). One-way ANOVA test was used to compare the values in all measuring area. When a statistically significant difference was calculated, Bonferroni correction was applied. Independent sample t-test was used to compare the TPTC between male and female subjects, and between anterior teeth (from mesial contact area of central incisor to mesial contact area of

canine) and posterior teeth (from distal contact area of canine to distal contact area of first molar). A value of  $P < .05$  was considered as statistically significant.

### RESULTS

The lowest TPTC and the highest TPTC were measured between the central incisors ( $0.88 \pm 0.37$  N), and between the right second premolar and first molar ( $1.94 \pm 0.76$  N) in maxilla, respectively. Also, the lowest TPTC and the highest TPTC were measured between the central incisors ( $0.87 \pm 0.20$  N), and between the left first molar and second molar ( $1.99 \pm 0.68$  N) in mandible (Table I). All TPTC per quadrant demonstrated a similar pattern of a

**Table I.** Tightness (N) of proximal tooth contact (left: maxilla, right: mandible)

Contact area	Mean (SD)
#17 - 16	1.73 (± 0.62)
#16 - 15	1.94 (± 0.76)
#15 - 14	1.53 (± 0.40)
#14 - 13	1.28 (± 0.49)
#13 - 12	1.12 (± 0.47)
#12 - 11	0.94 (± 0.41)
#11 - 21	0.88 (± 0.37)
#21 - 22	1.01 (± 0.48)
#22 - 23	1.09 (± 0.41)
#23 - 24	1.36 (± 0.49)
#24 - 25	1.49 (± 0.75)
#25 - 26	1.73 (± 0.71)
#26 - 27	1.65 (± 0.53)

Contact area	Mean (SD)
#47 - 46	1.83 (± 0.52)
#46 - 45	1.93 (± 0.64)
#45 - 44	1.60 (± 0.43)
#44 - 43	1.38 (± 0.48)
#43 - 42	1.04 (± 0.40)
#42 - 41	0.91 (± 0.28)
#41 - 31	0.87 (± 0.20)
#31 - 32	0.89 (± 0.20)
#32 - 33	0.92 (± 0.18)
#33 - 34	1.18 (± 0.42)
#34 - 35	1.43 (± 0.45)
#35 - 36	1.85 (± 0.63)
#36 - 37	1.99 (± 0.68)

**Table II.** Tightness (N) of proximal tooth contact of male and female subjects in maxilla (\* $P < .05$ , Independent samples t - test)

Contact area	Male Mean (SD)	Female Mean (SD)	P values
#17 - 16	1.94 (± 0.38)	1.52 (± 0.77)	
#16 - 15	2.14 (± 0.61)	1.76 (± 0.92)	
#15 - 14	1.79 (± 0.29)	1.27 (± 0.34)	*
#14 - 13	1.48 (± 0.61)	1.09 (± 0.26)	
#13 - 12	1.32 (± 0.54)	0.88 (± 0.24)	
#12 - 11	1.09 (± 0.43)	0.79 (± 0.37)	
#11 - 21	1.04 (± 0.42)	0.72 (± 0.25)	
#21 - 22	1.26 (± 0.53)	0.76 (± 0.29)	
#22 - 23	1.24 (± 0.40)	0.93 (± 0.41)	
#23 - 24	1.37 (± 0.42)	1.36 (± 0.60)	
#24 - 25	1.50 (± 0.61)	1.50 (± 0.94)	
#25 - 26	1.96 (± 0.67)	1.51 (± 0.75)	
#26 - 27	1.90 (± 0.28)	1.40 (± 0.63)	

**Table III.** Tightness (N) of proximal tooth contact of male and female subjects in mandible (\* $P < .05$ , Independent samples t - test)

Contact area	Male Mean (SD)	Female Mean (SD)	P values
#47 - 46	2.24 (± 0.34)	1.44 (± 0.31)	*
#46 - 45	2.26 (± 0.44)	1.60 (± 0.67)	
#45 - 44	1.76 (± 0.31)	1.44 (± 0.50)	
#44 - 43	1.43 (± 0.66)	1.27 (± 0.28)	
#43 - 42	1.07 (± 0.50)	1.00 (± 0.33)	
#42 - 41	0.92 (± 0.25)	0.90 (± 0.34)	
#41 - 31	0.87 (± 0.16)	0.86 (± 0.27)	
#31 - 32	0.81 (± 0.16)	0.98 (± 0.22)	
#32 - 33	0.88 (± 0.17)	0.96 (± 0.20)	
#33 - 34	1.09 (± 0.34)	1.27 (± 0.52)	
#34 - 35	1.41 (± 0.48)	1.44 (± 0.46)	
#35 - 36	2.09 (± 0.62)	1.60 (± 0.60)	
#36 - 37	2.44 (± 0.64)	1.54 (± 0.36)	*

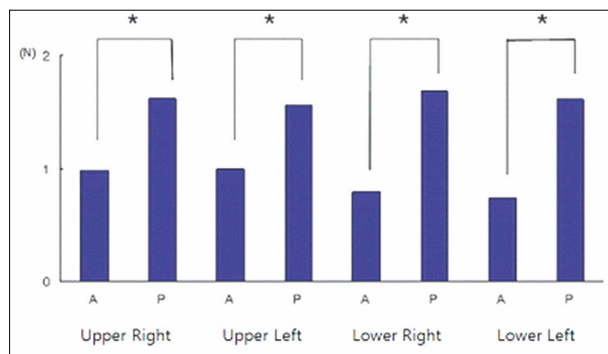

**Fig. 3.** Comparison of the proximal contact tightness between anterior teeth (A: from mesial contact area of central incisor to mesial contact area of canine) and posterior teeth (P: from distal contact area of canine to mesial contact area of second molar). (\* $P < .05$ , Independent samples t - test)

continuous increased gradient in an anterior-posterior direction. In both the maxilla and mandible, the TPTC was less in the anterior teeth than in the posterior teeth (Fig. 3). There are no significant difference between the maxilla and mandible at opposing area. Differences between male and female subjects failed to be statistically significant except upper right first premolar and second premolar, lower left first molar and second molar, lower right first molar and second molar (Tables II, III).

## DISCUSSION

Traditionally, dentists have believed that teeth make contact with adjacent teeth in the rest state. Southard *et al.*<sup>24</sup> reported that teeth made contact with some pressure at rest. Therefore, in constructing cast restorations, it was considered desirable to have proximal contacts.<sup>25-27</sup> However, some studies reported that human tooth possesses a small range of movement at resting position by pulsation in alveolar socket.<sup>28-30</sup> Especially, Kato<sup>29,30</sup> reported that the range of demonstrable space was from 0.25  $\mu\text{m}$  to 0.70  $\mu\text{m}$  resulted from measurement by displacement transducer. These reports supported that there is no proximal contact in the rest state in order to adaptation to pulsating action.<sup>31,32</sup> Kasahara *et al.*<sup>21</sup> observed spaces ranging from 3  $\mu\text{m}$  to 21  $\mu\text{m}$  between adjacent teeth at rest, using a charge coupled device microscope.

The device that used for this study is to measure the TPTC from the frictional force occurred during pulling the thin metal strip by electric motor after inserting the thin

metal strip to proximal surface. When the strip is inserted between two adjacent teeth, micro-displacement of teeth and reaction force from the strip contacts to each proximal surface occurs. As pulling out the strip parallel to the proximal surface, the frictional force occurs to the opposite to the pulling direction. The strain gauge of the device converts frictional force to compression force and the frictional force gradually increases until the strip moves, and the frictional force is maximal at the starting point of movement of the strip. This maximum frictional force is the TPTC of the proximal contact area. This force is recognized to electrical signal and displays on micro-processor. Especially, the removal speed of the metal strip was controlled constantly in order to avoid the effect of removal speed to frictional force. This device can measure the TPTC not only in rest state but also in occlusion because the metal strip is removed through the horizontal direction, not the occlusal direction. The maximum measurement range of this device was 98 N and statistical difference was  $\pm 0.02$  N. Oh *et al.*<sup>19</sup> reported that the range of the TPTC was 0.1 - 23 N at rest and 50% MVC (maximum voluntary contraction) clenching level of masseter muscle. Therefore, it could be considered that the accuracy of this device for measuring TPTC was favorable. If the metal strip of the thickness over interdental space is inserted between two adjacent teeth, the teeth are slightly displaced. Therefore, as the metal strip becomes thinner, more accurate measurement could be possible. However, too thin strip could be easily torn and there is a problem to control it intraorally. So, we used 0.03 mm-thickness metal strip. Metal strip of 0.03 mm-thickness is not only durable but also easy to use for clinicians.<sup>33</sup> This device was controlled that the metal strip could be removed at constant speed of 8 mm/s. Fuhrmann *et al.*<sup>33</sup> reported that there was no significant correlation between TPTC and removal speed of metal strip in the velocity range of 0.83 - 8.33 mm/s. For convenience, there was a limit switch which could make the metal strip return right after measurement. In our study, the TPTC was measured in all dentition using this device. We statistically compared value of TPTC of all measured area. Also, TPTC was compared between maxilla and mandible in opposing area, between males and females in same area. The results were as follows.

First, the TPTC was observed to be decreasing from

posterior to anterior teeth in same arch. In the results of the statistical analysis, there were statistically significant differences between anterior area and posterior area. This result supported the previous study.<sup>10</sup> The proximal contact of anterior teeth was unstable and resulted in spacing or crowding. The size, number, and divergency of the roots of anterior teeth can result the decreased resistance force. This can be explained by the resistance theory that we mentioned for the second theory of maintenance of the proximal tooth contact tightness.<sup>10</sup>

Second, as we compared the TPTC between maxilla and mandible, a higher TPTC was observed in the maxilla compared with the mandible. However, there were no statistically significant differences. Proffit<sup>34</sup> explained it by the balanced TPTC system, similar to oral muscle balancing theory. Exactly, the TPTC is increased when the muscle functions like mastication and this effect is distributed equally to both arches. Therefore, the TPTC between maxilla and mandible becomes similar.

Third, we compared the TPTC between male and female. As a result, there were no statistically significant differences except upper right first premolar and second premolar, lower left first molar and second molar, lower right first molar and second molar. However, opposing to our study, Alexander *et al.*<sup>10</sup> reported that the TPTC was higher in male than in female. They considered that the masticatory force of male is stronger than that of female.<sup>35,36</sup> Even though, there were no statistically significant differences in this study. More research is needed to clarify this relationship. We measured at the same time of the days. Dörfer *et al.*<sup>20</sup> reported that the TPTC at rest increase from morning to noon, and then decrease in the afternoon, and it was explained by fatigue and mucoelastic characteristic of periodontal ligament. However, the differences were very small. Throughout the day, most of the high activity levels of the masticatory muscle appear mainly during meals.<sup>37</sup> Considering these variations, all measurement were conducted around 4 PM, allowing sufficient time after the lunchtime meal.

Teeth are displaced when the jaw is in function. In addition, the direction of tooth displacement is closely related to the occlusal contact patterns of opposing teeth. Vertical factor of the force tends to intrude tooth to alveolar socket, and horizontal factor, to displace tooth mesially. The

mesial force distributed to the proximal contacts of many teeth and affects the TPTC.<sup>38,39</sup> Not only tooth, but also alveolar bone tends to be displaced, especially in the mandible.<sup>40</sup> Koriath *et al.*<sup>41</sup> analyzed the change of the TPTC occurred due to deformation of the mandible, and observed the higher TPTC of balancing side, compared with working side. Therefore, we limited food ingestion for one hour before measurement in order to avoid the effect of tooth displacement and mandibular deformation during function. But the tooth contact or occlusal force occurred during function like swallowing or clenching was not controlled. There was resting time of more than 2 minutes at every measurement. This resting time was for recovering previous position of tooth after measurement.<sup>24</sup>

In our study, we measured the TPTC at rest state without any tooth contact. However, Kato<sup>29</sup> reported that teeth displace during occlusion and it affects to the TPTC. Oh *et al.*<sup>19</sup> reported that TPTC was higher during occlusion than at rest. Therefore, it is considered to be needed analyzing the TPTC during not only resting state but also function state.

## CONCLUSION

In this study, we measured the frictional force which occurred when the metal strip (stainless steel strip - 2 mm width, 0.03 mm thickness) was inserted to the proximal surface and was removed at constant speed by the electric motor, then we obtained the value of the TPTC in all contact areas. As a result, in both maxilla and mandible, the TPTC was less in the anterior teeth than in the posterior teeth. However, there was no significantly difference between maxilla and mandible, and between male and female.

## REFERENCES

1. Andrews LF. The six keys to normal occlusion. *Am J Ortho* 1972;62:296-309.
2. The academy of prosthodontics. The glossary of prosthodontic terms 8th ed. (GPT-8) *J Prosthet Dent* 2005;94:46.
3. Wheeler RC. An atlas of tooth form, 4th ed. Philadelphia, W.B. Saunders Co; 1969:12.
4. Sluder TB. Clinical dental anatomy, histology, physiology and occlusion. In: Studevart CM, ed. The art and science of operative dentistry, 2nd ed. New York: McGraw-Hill; 1985:21.

5. Hirschfeld I. Food impaction. *J Am Dent Assoc* 1930;17:1504-28.
6. Gould MSE, Picton DCA. The relation between irregularities of the teeth and periodontal disease. *Br Dent J* 1966;121:20-3.
7. Hancock EB, Mayo CV, Schwab RR, Wirthlin MR. Influence of interdental contacts on periodontal status. *J Periodontol* 1980;51:445-9.
8. Nielson IM, Glavand L, Karring T. Interdental periodontal intrabony defects. Prevalence, localization and etiological factors. *J Clin Periodontol* 1980;7:187-98.
9. Jernberg GR, Bakdash MB, Keenan KM. Relationship between proximal tooth open contacts and periodontal disease. *J Periodontol* 1983;54:529-33.
10. Vardimon AD, Matsaev E, Lieberman M, Brosh T. Tightness of dental contact points in spaced and non-spaced permanent dentitions. *Eur J Orthod* 2001;23:305-14.
11. Barnes DM, Blank LW, Thompson VP, Hoston AM, Gingell JC. A 5-and 8-year clinical evaluation of a posterior composite resin. *Quintessence Int* 1991;22:143-51.
12. Prakki A, Cilli R, Saad JOC, Rodrigues JR. Clinical evaluation of proximal contacts of Class II esthetic direct restoration. *Quintessence Int* 2004;35:785-9.
13. Campagni WV. The final touch in the delivery of a fixed prosthesis. *CDA J* 1984;12:21-9.
14. Lindquist JT. Thesis: A study of the intra-arch relationships in normal human dentitions, Indiana University School of Dentistry, 1951.
15. Boice PA, Niles SM, Dubois LM. Evaluation of proximal contacts with shim stock. *J Oral Rehabil* 1987;14:91-4.
16. Dubois LM, Niles SM, Boice PA. The magnitude of interproximal spaces between adjacent teeth. *Am J Dent* 1993;6:315-7.
17. Osborn JW. An investigation into the interdental forces occurring between the teeth of the same arch during clenching the jaws. *Arch Oral Biol* 1961;5:202-11.
18. Southard TE, Southard KA, Tolley EA. Variation of approximal tooth contact tightness with postural change. *J Dent Res* 1990;69:1776-9.
19. Oh SH, Nakano M, Bando E, Keisuke N, Shigemoto S, Jeong JH, Kang DW. Relationship between occlusal tooth contact patterns and tightness of proximal tooth contact. *J Oral Rehabil* 2006;33:749-53.
20. Dörfer CE, von Bethlenfalvy ER, Staehle HJ, Pioch T. Factors influencing proximal dental contact strength. *Eur J Oral Sci* 2000;108:368-77.
21. Kasahara K, Miura H, Kuriyama M, Kato H, Hasegawa S. Observations of interproximal contact relations during clenching. *Int J Prosthodont* 2000;13:289-94.
22. Choi WJ, Kim KH, Kim JA, Knag DW, Oh SH. Evaluation and development of digital device for measuring proximal tooth contact tightness. *J Korean Acad Prosthodont* 2007;45:687-95.
23. Picton DC. Some implications of normal tooth mobility during mastication. *Arch Oral Biol* 1964;9:565-73.
24. Southard TE, Southard KA, Tolley EA. Periodontal force: a potential cause of relapse. *Am J Orthod Dentofacial Orthop* 1992;101:221-7.
25. Eissmann, HF. Wax pattern fabrication. In: Eissmann HF, Rudd KD, Morrow RM, eds. *Dental Laboratory Procedure-fixed partial denture*. St. Louis, MO, USA: C.V. Mosby Co. 1980:144-6.
26. Sturdevant JR. & Sturdevant CM. Gold inlay and gold onlay restoration for Class II cavity preparations. In: Sturdevant C, Barton R, Sockwell C, Strickland W, eds. *The Art and Science of Operative Dentistry*. St. Louis, MO, USA: C.V. Mosby Co. 1985:pp 490.
27. Malone WFP, Koth DL, Cavazos E Jr, Kaiser DA, Morgano SM. Laboratory support for fixed prosthodontics. In: Gregore H, ed. *Theory and Practice of Fixed Prosthodontics*, 8th ed, St. Louis, MO, USA: Ishiyaku EuroAmerica 1993:288-9.
28. Körber KH. Periodontal Pulsation. *J Periodontol* 1970;41:382-90.
29. Kato H. The function of the tooth supporting structures. Part I. A method of measuring tooth displacement in two dimensions. *J Jpn Prosthodont Soc* 1981;25:733-45.
30. Kato H. The function of the tooth supporting structures. Part II. The dynamics of molars in function and at rest. *J Jpn Prosthodont Soc* 1982;26:133-47.
31. Miura H. A measurement of the physiological tooth displacement in horizontal plane in function. *J Jpn Prosthodont Soc* 1985;29:735-54.
32. Miura H. A study on the interdental proximal contact relation. *J Jpn Prosthodont Soc* 1985;29:1134-42.
33. Oh SH, Nakano M, Bando E, Shigemoto S, Kori M. Evaluation of proximal tooth contact tightness at rest and during clenching. *J Oral Rehabil* 2004;31:538-45.
34. Fuhrmann R, Grave C, Diedrich P. In vitro evaluation of a measurement method to analyze the interdental, mesially directed force. *J Orofacial Orthop* 1998;59:362-70.
35. Proffit WR. Equilibrium theory revisited: factors influencing position of the teeth. *Angle Orthod* 1978;48:175-86.
36. Kiliaridis S, Johansson A, Haraldson T, Omar R, Carlsson GE. Craniofacial morphology, occlusal traits and bite force in persons with advanced occlusal tooth wear. *Am J Orthod Dentofacial Orthop* 1995;107:286-92.

37. Waltimo A, Könönen M. A novel bite force recorder and maximal isometric bite force values for healthy young adults. *Scan J Dent Res* 1993;101:171-5.
38. Miyamoto K, Yamada K, Ishizuka Y, Morimoto N, Tanne K. Masseter muscle activity during the whole day in young adults. *Am J Orthod Dentofacial Orthop* 1996;110:394-8.
39. Southard TE, Behrents RG, Tolley EA. The anterior component of occlusal force: Part I. Measurement and distribution. *Am J Orthod Dentofacial Orthop* 1989;96:493-500.
40. Omar R, Wise MD. Mandibular flexure associated with muscle force applied in the retruded axis position. *J Oral Rehabil* 1981;8:209-21.
41. Koriath TWP, Versluis A, Beyer JP. Numerical simulation of approximal dental contact forces during clenching. *J Dent Res* 1997;76:245-50.

## EVALUATION OF TIGHTNESS OF PROXIMAL TOOTH CONTACT IN PERMANENT DENTITION

Kyoung-Hwa Kim<sup>1</sup>, DDS, MSD, J-Hyun Jung<sup>1</sup>, DDS, MSD,

Hee-Jung Kim<sup>2</sup>, DDS, MSD, PhD, Chae-Heon Chung<sup>3</sup>, DDS, MSD, PhD, Sang-Ho Oh<sup>2\*</sup>, DDS, PhD

<sup>1</sup>Graduate Student, Department of Prosthodontics, School of Dentistry, Chosun University,

<sup>2</sup>Assistant Professor, Department of Prosthodontics, School of Dentistry, Chosun University

<sup>3</sup>Professor, Department of Prosthodontics, School of Dentistry, Chosun University

**STATEMENT OF PROBLEM:** Proximal contact plays an important role in the stability and maintenance of the integrity of the dental arches. However, it is difficult to evaluate quantitatively the tightness of proximal tooth contact (TPTC). **PURPOSE:** The aim of this study was to measure the TPTC in permanent dentition. **MATERIAL AND METHODS:** Ten young adult volunteers with healthy dentition participated in this experiment. The TPTC between the teeth of both the maxilla and the mandible was measured at rest state by a novel device which records the TPTC by pulling of a stainless steel strip (0.03 mm thick) using the electric motor. One-way ANOVA test was used to compare the values in all measured area. When a statistically significant difference was calculated, Bonferroni correction was applied. Independent samples t-test was used to compare the values in male and female. **RESULTS:** The lowest TPTC and the highest TPTC was measured between the lower central incisors ( $0.87 \pm 0.20$  N), and between the lower left first molar and second molar ( $1.99 \pm 0.68$  N), respectively. All TPTC per quadrant demonstrated a similar pattern of a continuous increased gradient in an anterior-posterior direction. There are no significant difference between the maxilla and mandible. **CONCLUSION:** The TPTC was measured quantitatively by a novel device and decreased progressively in a posterior-anterior direction.

**KEY WORDS:** Proximal contact, Frictional force, Dentition

Corresponding Author: Sang-Ho Oh

Department of Prosthodontics, School of Dentistry, Chosun University

375 Seosuk-Dong, Dong-Gu, Gwangju, 501-759, Korea +82 62 220 3828: e-mail, shoh@chosun.ac.kr

Article history

Received September 16, 2008 Last Revision November 14, 2008 Accepted November 20, 2008.