

The Next Generation Apartment Model Far Infrared Rays Radiant Heater using Quasi-Resonant Soft Switching PWM Inverter

Soon-Kurl Kwon* · Sang-Pil Mun

Abstract

This paper presents an innovative prototype of a new conceptual electromagnetic induction heated type far infrared rays radiant heating appliance using the voltage-fed quasi-resonant ZVS-PWM high frequency inverter using IGBTs for food cooking and processing which operates under a constant frequency variable power regulation scheme. This power electronic appliance with soft switching high frequency inverter using IGBTs has attracted special interest from some advantageous view points of safety, cleanliness, compactness and rapid temperature response, which is more suitable for consumer power electronics applications.

Key Words : ZVS-PWM high frequency, Electromagnetic induction heated, Food cooking and processing, Far Infrared Rays Radiant Heater

1. Introduction

Gas combustion heating system and sheath wired heating system for consumer home and business applications are usually used as the heating means for the food cooking and processing as well as the fluid processing in pipeline. Besides, low frequency and high frequency electromagnetic induction heating (IH) methods have been considered for food cooking and processing in business-use production plants and household

kitchen applications. This actual heating efficiency is relatively high for new consumer IH appliances as compared with traditional food cooking and fluid processing appliances[1].

The induction heating appliances using power electronics circuits are more excellent in respect of energy saving, temperature control, clean environment, quick heating processing, safety and reliability. These appliances are utilized in various power application fields for food cooking and fluid processing such as boiling, baking and steaming. The high frequency quasi resonant inverters and high frequency resonant cyclo-converters as a direct frequency converter are essentially indispensable for implementing the heating controllability, high efficient heating in addition to improvements of cleanliness, safety and reliability

* Main author : Department of Electrical Engineering, Professor Kyungnam University, KOREA

Tel : +82-55-249-2633, Fax : +82-55-249-2839

E-mail : soonkurl@kyungnam.ac.kr

Date of submit : 2008. 6. 10

First assessment : 2008. 6. 18

Completion of assessment : 2008. 7. 3

of the heating processing in the high efficient power conversion stages. For a moment, the voltage-fed single ended quasi resonant ZVS PFM high frequency inverter using a single IGBT for the commercial utility AC 110[V] grid has been developed so far for cost effective practical power applications. This type of high frequency ZVS inverter has attracted special interest because of low cost, compact, high-efficiency, low noise. But, audible acoustic noise below 20[kHz] due to a little frequency difference causes in multi burner system composed of PFM control-based ZVS inverter scheme, voltage peak stress across the power switching semiconductor device: IGBT becomes extremely high. The soft switching operating range of this inverter is relatively small[2-4].

In recent years, the modified topologies of ZVS PWM high frequency inverter added an auxiliary active power switch connected in series with the capacitor for voltage clamping on the basis of conventional single ended high frequency inverter are practically developed for utility AC 110[V] or 220[V] grid consumer power applications[5].

This paper presents an innovative prototype of the voltage-fed high frequency quasi-resonant soft switching inverter using IGBTs, which is based upon asymmetrical PWM control scheme due to duty cycle time ratio control (TRC), which is newly developed for electro-magnetic induction eddy current based far infrared rays radiant heating as a new generation griddle for food cooking processing. Its operation principle and unique salient features of this consumer power electronic appliance using high frequency inverter are described and discussed on the basis of computer-aided simulation and feasible experimental results, along with power regulation characteristics.

2. Quasi-resonant ZVS-PWM High Frequency Inverter for Induction Heated

2.1 Induction Heating Load Technology

The produced induction heating griddle appliance using the high frequency edge resonant TRC inverter for consumer power electronic applications is shown in Fig. 1.

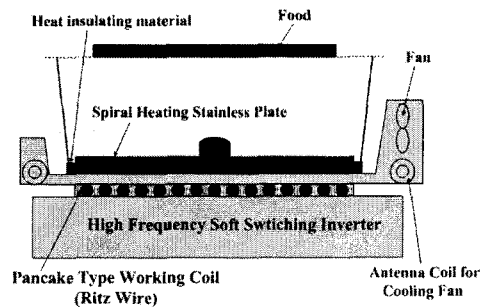

Fig. 1. Griddle power appliance using electromagnetic induction heating ranges

This consumer power appliance is composed of the eddy current-based planar spiral stainless steel heating plate: SUS304 (70~80[$\mu\Omega\text{cm}$]), wool board called ceramic fiber for heat insulating material, pancake type working coil, the voltage-fed high frequency soft switching PWM inverter without a matching transformer, forced air cooling fan-based DC motor drive controlled by using the induced voltage frame a pancake type coil. The output current obtained from the voltage-fed high frequency soft switching PWM inverter flows through the working coil made of litz wire. The eddy current is directly induced into the spiral sheet type planar stainless steel plate by the electromagnetic induction principle and its plate is directly heated on the basis of joule law. It is noted that this IH appliance is to make use of the

radiant heat from spiral planar stainless steel plate.

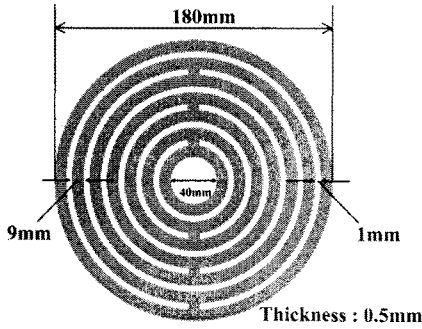

Fig. 2. Eddy current-based heating plate shape

2.2 Equivalent Transformer Model of Induction Heating Load

The equivalent electrical model of the IH load can be represented as a transformer shown in Fig. 3. Here L_1 is a self inductance of the working coil, which is defined by the high frequency magnetic flux caused by inverters current, R_2 is a frequency dependent resistance of the roller caused by the skin effect.

The inductance of the transformers second side and mutual inductance are defined as L_2 and M , respectively.

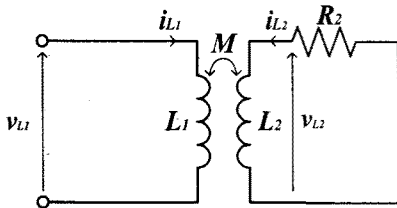

Fig. 3. Transformer model of induction heating load

If the internal resistance of the working coil is neglected, circuit equations can be derived as

$$\begin{cases} j\omega L_1 I_{L1} + j\omega M I_{L2} = V_{L1} \\ j\omega M I_{L1} + (j\omega L_2 + R_2) I_{L2} = 0 \end{cases} \quad (1)$$

After simple transformations, equation (2) can be obtained

$$\frac{V_{L1}}{I_{L1}} = \frac{\omega^2 M^2 R_2}{R_2^2 + \omega^2 L_2^2} + j\omega \frac{L_1 R_2^2 + \omega^2 L_2 (L_1 L_2 - M^2)}{R_2^2 + \omega^2 L_2^2} \quad (2)$$

If the first term of equations (2) is considered as R_a and the factor of the second $j\omega$ is represented as L_a , then L_a and R_a can be given by

$$\begin{cases} R_a = \frac{\omega^2 M^2 R_2}{R_2^2 + \omega^2 L_2^2} \\ L_a = L_1 - \frac{\omega^2 L_2 M^2}{R_2^2 + \omega^2 L_2^2} \end{cases} \quad (3)$$

As a result, the transformer model of the induction heating load shown in Fig. 3 can be represented by R_a - L_a parameters that can be measured experimentally.

For the load shown in Fig. 1, such parameters as transformers electromagnetic mutual coupling coefficient k and time constant of the IH load τ can be defined as:

$$\begin{cases} k = \frac{M}{\sqrt{L_1 L_2}} \\ \tau = \frac{L_2}{R_2} \end{cases} \quad (4)$$

If time constant τ of the IH load is constant, the circuit behavior of the IH load is the same for any value L_2 and R_2 . Therefore, it is better to represent the IH load by using new parameters L_a , k and τ defined as (4) rather than using the circuit parameters of the equivalent transformer circuit depicted in Fig 3, where L_1 is measurable and L_2 , M and R_2 cannot be measured. If k and τ from (4) are represented by measurable parameters R_a , L_a and L_1 , it become simple to analyze the operation of the inverter circuit with the IH load.

2.3 Gate pulse control implementation

Fig. 4 illustrates timing asymmetrical PWM pulse sequences for the high frequency inverter shown in Fig. 5. These voltages pulses are supplied to the power semiconductor switching block; Q_1 (S_1 & D_1) and Q_2 (S_2 & D_2). Duty Factor defined as $D = t_{on}/T$ serves as a control variable for the continuous power regulation for this quasi-resonant soft switching PWM inverter using IGBTs. Duty Factor is designed as a ratio of the conduction time including a dead time of the main active power switches during one period. When the full power is delivered to the load, the conduction time of the main active power switch during one cycle is lengthened as indicated in Fig. 4 (a). On the other hand, when the full power is not required for load, the conduction interval is shortened as indicated in Fig. 4 (b).

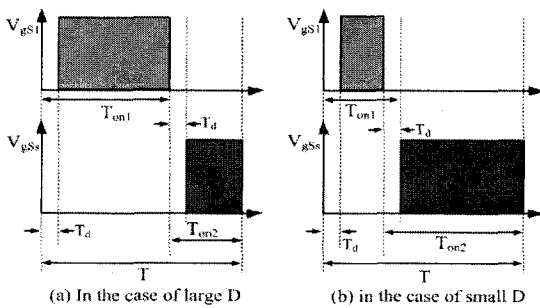

Fig. 4. Asymmetrical PWM gate voltage pulse signal sequences

2.4 System Description & Circuits Operation

Fig. 5 shows a schematic total system configuration including a high frequency quasi-resonant inverter circuit topology using two IGBTs that can operate under a principle of ZVS and a constant frequency asymmetrical PWM control strategy.

This high frequency inverter topology is newly applied for an electromagnetic induction eddy current based far infrared rays radiant heating appliance as a new generation griddle for food cooking and processing. The voltage-fed high frequency ZVS inverter with the duty cycle control based variable power constant frequency (VPCF) function is connected to a single phase utility AC 110[V] grid or 220[V] grid, the full bridge diode rectifier with the smoothing filter as shown in Fig.

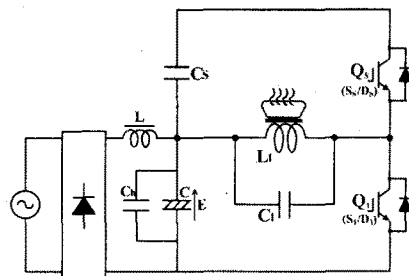

Fig. 5. Proposed quasi-resonant high frequency inverter system

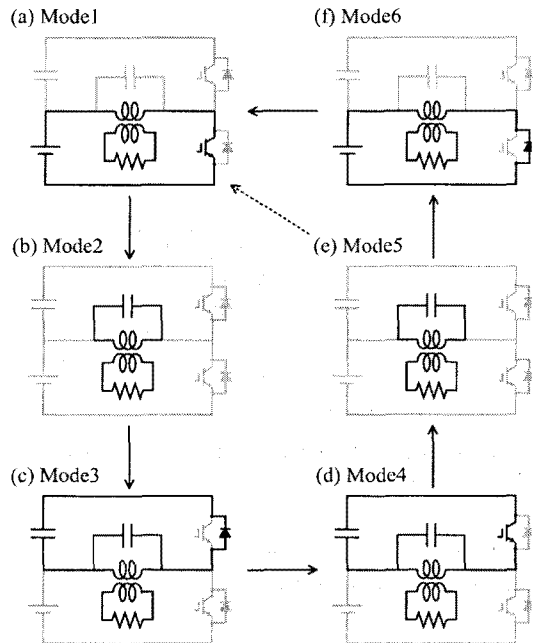

Fig. 6. Mode transition and equivalent circuits

5. Fig. 6 depicts the equivalent circuits for each operating mode of this quasi-resonant soft switching PWM inverter in Fig. 5.

Fig. 7 illustrates the steady state switching voltage and current waveforms of the main and auxiliary active power switching blocks; $Q_1(S/D_1)$, $Q_5(S_5/D_5)$, capacitor voltages V_{C1} and V_{C5} across C_1 and C_5 under two conditions of $D=0.5$. Observing V_{S1} in Fig. 7, it is noted that ZVS mode transition can be completely achieved for this inverter.

The simulation and experimental results of this appliance are illustrated and its steady-state performances are evaluated from a practical point of view. In practice, (a) input power, (b) resonant initial current, (c) main active power switch short voltage V_{LON} , (d) auxiliary active power switch short voltage V_{SON} , (e) main active power switch

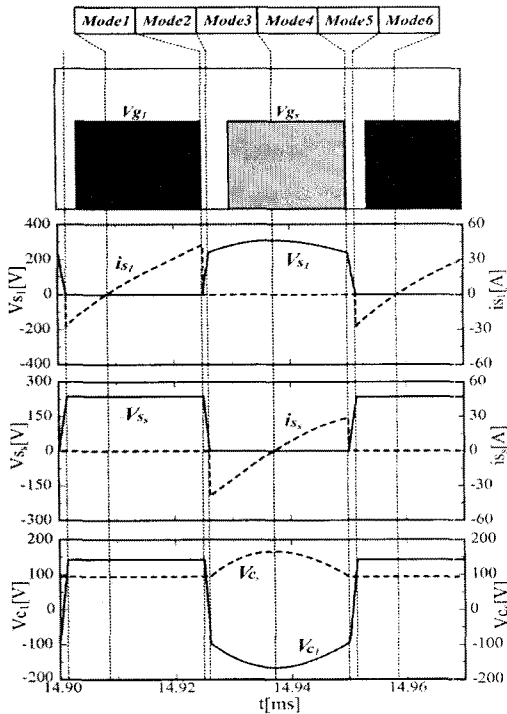

Fig. 7. Steady state voltage and current switching waveforms for two duty cycle control conditions ($D=0.5$)

peak voltage V_{S1} , (f) main active power switch peak current i_{s1} , (g) auxiliary active power switch peak voltage V_{S5} and (h) auxiliary active power switch peak current i_{s5} peak value of varying Duty Cycle are shown respectively in Fig. 8.

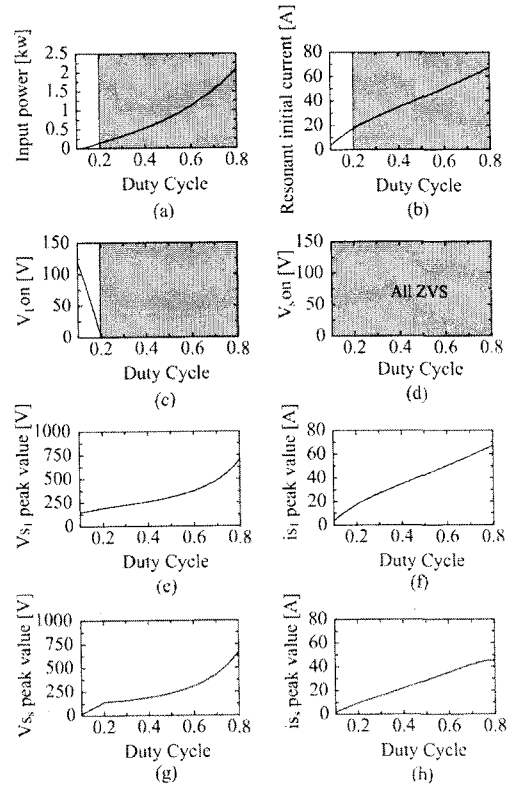

Fig. 8. Various inverter characteristics for Duty Cycle Control

Main active power switch S_1 operates under a condition of ZVS when D is more than 0.2, and it becomes a hard switching when D is smaller than 0.2. The auxiliary active power switch S_5 can operate under a condition of ZVS in spite of the duty cycle D control scheme. This high frequency quasi-resonant soft switching PWM inverter can continuously control electric power at the constant frequency. In addition to this, the soft switching operation of this inverter is able to be done in 90[%] of the maximum duty cycle D . The ZVS of

this inverter is not possible in the stand by electric power state when D is less than 0.2.

4. Experimental Results and Their Evaluations

Table 1 indicates the practical design specifications and circuit parameters of the feasible electromagnetic induction eddy current based far infrared ray's radiant heating appliance, which is built and tested by quasi resonant ZVS-PWM high frequency inverter using the latest IGBT modules.

Table 1. Design specifications and circuit parameters

Parameter	Value
DC Voltage Source E	141.4[V]
Switching Frequency f	20.0[kHz]
Working Coil L_1	65.1[mH]
Quasi-Resonant Capacitor C_1	0.18[mF]
Clamp Capacitor C_s	3.0[mF]
Time Constant t	12.5[ms]
Electromagnetic Coupling Coefficient k	0.652

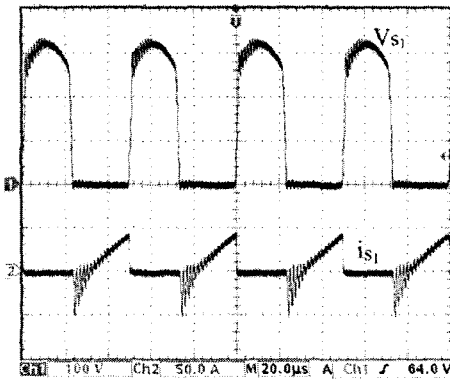

(a) For switching block Q1

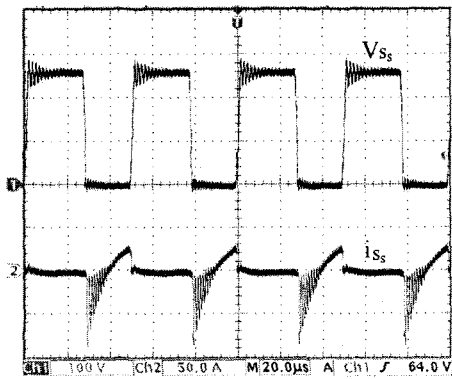

(b) For switching block Qs

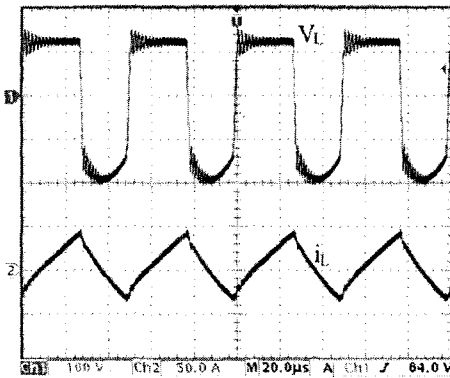

(c) For load circuit

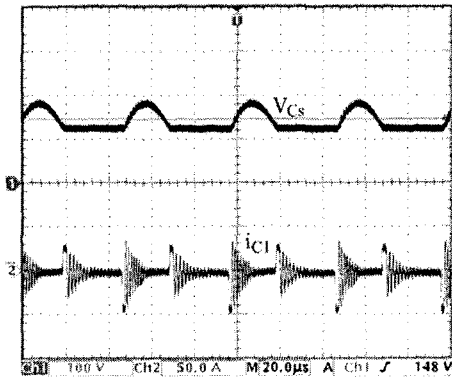

(d) For voltage of C_s and current of C_1

Fig. 9. Observed voltage and current waveforms (100[V/div], 50[A/div], 20[usec], D=0.5)

Fig. 9 (a), Fig. 9 (b) and Fig. 9 (c) depict the measured voltage and current waveforms of the main active power switching block; $Q_1(S_1/D_1)$, voltage and current waveforms of the auxiliary active power switching block; $Q_s(S_s/D_s)$ and electromagnetic induction heated load (see Fig. 1 and Fig. 2) under a condition of $D=0.5$. These measured voltage and current waveforms have a good agreement with simulated result on the simulation software developed by the authors. It is proved that this quasi-resonant ZVS-PWM high frequency inverter with VPCF scheme can completely work under a soft switching operation for a wide duty cycle control implementation. In addition, this quasi-resonant high frequency inverter can clamp an excessive peak voltage applied to the main active power switch. Accordingly, the conduction power losses and current stresses of the switching power semiconductor devices (IGBTs) can be effectively reduced for this soft switching inverter.

Fig. 10 represents duty cycle D vs. input power regulation characteristics under a fixed frequency (20kHz) asymmetrical PWM control strategy. Observing Fig. 11, it is clearly proved that Duty Cycle as a control variable can be continuously adjusted in the accordance with the inverter output power. Fig. 11 illustrates temperature characteristics of the spiral planar stainless heating plate using high frequency inverter type induction heating for setup in experiment. It is noted that this electromagnetic induction eddy current heated far infrared radiant heating processing scheme can more rapidly heat than that of general purpose gas combustion type or sheathed wired heating type heater for consumer power applications.

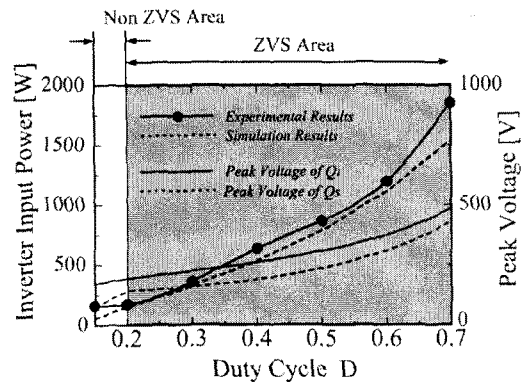

Fig. 10. Duty cycle vs. input power characteristics

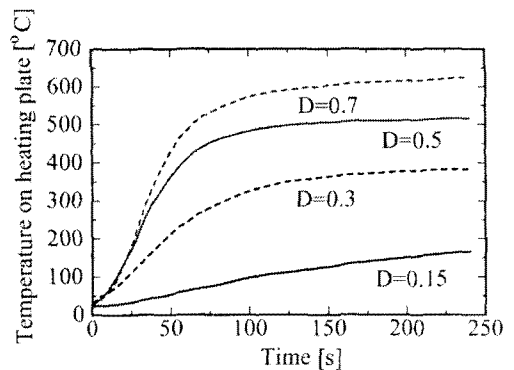

Fig. 11. Temperature characteristics of induction heated stainless steel plate

5. Conclusion

In this paper, an innovative new implementation of the electromagnetic induction eddy current based far infrared rays radiant heating appliance has been successfully proposed as a next generation consumer product which incorporates a voltage-fed type active clamped quasi-resonant ZVS-PWM high frequency inverter using the latest IGBTs power modules. This soft switching duty cycle controlled inverter can efficiently operate under soft switching on the basis of asymmetrical PWM strategy and load variations. Its operation analysis and power regulation characteristics in addition to voltage and current

stresses of the power switching devices have been evaluated in spite of simulation and experimental results. The new and efficient induction heated far infrared rays radiant heating appliance using high frequency inverter could be cost effective than the gas combustion heating. Furthermore, this inverter type appliance could be applied for a variety of industrial, consumer, electric vehicle, heat energy processing utilization plants.

In the future, the power loss analysis of this soft switching high frequency inverter using the trench gate IGBTs for soft switching should be done and the new generation power electronics appliances for electro-magnetic induction eddy current heated far infrared rays radiant heating should be evaluated and discussed from an application point of view. The optimum computer-aided design procedure of this power electronics appliances using a new inverter topology treated here should be discussed from a theoretical point of view.

This work is supported by the Kyungnam University Research Fund, 2008.

References

- [1] Monterde, Hernandez, R. Garcia, Martinez; "Comparison of Control Strategies for Series-Resonant Full-Bridge Inverter for Induction Cookers", Proceedings of The 8th European Conference on EPE, vol.1~4, pp.1-8(CD-ROM), Sept, 1999.
- [2] B. K. Lee, J. W. Jung, B. S. Suh, D. S. Hyun; "A New Half-Bridge Inverter Topology with Active Auxiliary Resonant Circuit Using Insulated Gate Bipolar Transistors for Induction Heating Appliances", Proceedings of IEEE-PESC, Vol.2, pp.1232-1237, June, 1999.
- [3] S. Kubota, Y. Hatanaka, "A Novel High Frequency Power Supply for Induction Heating," in Proc. of IEEE-PESC, Vol.1, pp.165-171, June, 1998.
- [4] Y. Hatanaka, H. Kifune and T. Shimada, "A Novel ZCS High Frequency Inverter with Complex Resonance and Design Procedure for High Amplitude of Output Current," in Proc. of IEEE-PEDS, Vol.1, pp.443-447, September, 2001.
- [5] Y. L. Feng, Y. Konishi, M. Nakaoka, "Current-Fed Soft-Switching Inverter with PDM-PWM Control Scheme for Ozone Generation Tube Drive," Trans. IEE of Japan, Vol.120-D, No.10, pp.1239-1240, 2000.

Biography

Soon-Kurl Kwon

Received Ph. D (Dr-Eng) degree in Electrical Engineering from Young-Nam University, Daegu, Republic of Korea. He joined the Electrical Engineering Department of Kyungnam University, Masan, Republic of Korea, in 1983 as a professor. He was a visiting professor of Virginia Polytechnic Institute and State University, USA in 1997. His research interests include application developments of power electronics circuits and system. He is a member of the KIEE and KIPE.

Sang-Pil Mun

Received B.S. degree in Electrical Engineering from Pukyong University, Pusan, Korea in 1997 and M.S. and Ph.D. degrees in Electrical Engineering from Kyungnam University, Masan, Korea in 1999 and 2003 respectively. He was joined with the Electrical Energy Saving Research Center, Kyungnam University from 2003~2005 as a researcher. His research interests are in the areas of photovoltaic power generation systems, power electronics, soft-switching technology. He is a member of the KIEE, KIPE, KIIEE.