

Pedagogical Paradigm-based LIO Learning Objects for XML Web Services

Haeng-ja Shin[†], Kyung-hwan Park^{**}

ABSTRACT

In this paper, we introduce the sharable and reusable learning objects which are suitable for XML Web services in e-learning systems. These objects are extracted from the principles of pedagogical paradigms for reusable learning units. We call them LIO (Learning Item Object) objects. Existing models, such as Web-hosted and ASP-oriented service model, are difficult to cooperate and integrate among the different kinds of e-learning systems. So we developed the LIO objects that are suitable for XML Web services. The reusable units that are extracted from pedagogical paradigms are tutorial item, resource, case example, simulation, problems, test, discovery and discussion. And these units correspond to the LIO objects in our learning object model. As a result, the proposed model is that learner and instruction designer should increase the power of understanding about learning contents that are based on pedagogical paradigms. By using XML Web services, this guarantees the integration and interoperation of the different kinds of e-learning systems in distributed environments and so educational organizations can expect the cost reduction in constructing e-learning systems.

Keywords: Learning Object, XML Web Service, LIO object, Pedagogical Paradigm, E-Learning System

1. INTRODUCTION

An e-learning system provides the technological environments for educational organizations to perform e-learning. Up to the present, e-learning systems are being introduced as the mixtures of external expert development, management and operation which are hosted by Web and ASP service model. This has the advantage of keeping an educational system flexible and performable by continuously performing upgrade and all other related services. However, under this decentralized computing environments, ASP service model requires

huge initial cost as well as time consuming environment for the integration of application and customization. In addition, the client-server technologies such as CORBA, DCOM and RMI, are difficult to be accepted in Internet because of the lack of security and reliability as well as frailty of firewall under open network environments. Again, if e-learning solution is following after ASP model, it can not expect ROI (Return on Investment). Because of these limits of ASP, we choose an XML Web service model as a best e-learning solution for decentralized environments. By constructing XML Web services, we have extracted the LIO object which is based on pedagogical paradigms in order to increase reusability and interoperability. Also, we describe the service interface for using these models.

2. RELATED WORKS

Recently, a new approach for developing learning objects has been increasingly gaining attention

* Corresponding Author : Kyung-hwan Park, Address : (604-714) Department of Computer Engineering, Dong-A University, 840 Hadan-dong, Saha-gu, Busan, Korea, TEL : +82-51-200-7779, FAX : +82-51-200-7783, E-mail : khpark@dau.ac.kr

Receipt date : July 5, 2007, Approval date : Aug. 7, 2007

[†] Department of Computer Engineering, Dong-A University (E-mail : hjshin@dau.ac.kr)

^{**} Department of Computer Engineering, Dong-A University

* This Paper was supported by the Dong-A University Research Fund in 2005.

among educational technology and computer science researchers. The IEEE Learning Technology Standards Committee(LTSC) has defined the learning object as the digital or non-digital entity that can be used and reused or referenced during the course of learning[1]. Also, IDC has given the definition of a learning object as a unit which includes contents and evaluation that is based on specific learning objective and add metadata to symbolize such learning unit[2]. Also, a learning object is called a contents object or a knowledge object by ADL SCORM(Advanced Distributed Learning, Sharable Content Object Reference Model)[3]. IMS(Instructional Management System) had no comments for these terms other than using a learning resource as a concept [4]. And many other perspectives on learning objects exists[5-7]. According to these definitions for a learning object, we may find that the definition of LTSC is too comprehensive and the IMS resource contains passive meaning of a readable material for learning. The definition of SCORM contains a wider scope of contents than the educational scope of contents. In this paper, we define a learning object as a self-contained, reusable digital contents that is applicable in e-learning system. Thus learning objects are fundamental elements of a conceptual model for content creation and course composition in e-learning system.

2.1 Reusable Unit in Pedagogical Paradigms

The notion of reusable units in a learning environment has a lot of merit to both educators and designers of e-learning environments. A pedagogical paradigm is an approach to understand the process of teaching and learning. Many methodologies of instructional design has been researched according to the changes in educational environments.

In tutorial, drill and practice, the extractable units for reusability are tutorial subjects and related questions. Learning is carried out in a form of tutorial-drill-evaluation. In case study method, learner

needs to analyze samples to be instructed and be able to practice it. Therefore, the reusable unit could be a sample of stories which are based on real life situations. In problem-based learning, it presents the study which are certified in various fields and sought in solutions. The reusable unit is a question. In exploratory learning, the reusable unit is the resource to learn and the discovery to find. In this method, the actual fact or concept could be found because the learning is accomplished by going through the process of presenting issue, building hypothesis, designing experiment, verifying hypothesis by collecting data and making decisions. In resource-based learning the reusable unit is a resource, because in this method the learning is accomplished by the action of system utility surrounding the learner. In goal-based learning, a corresponding scenario or simulation is required because in this method the learning is accomplished by the learner that seeks the solutions through intentionally curtailed situations. Therefore, the reusable unit in this paradigm is a simulation[8]. All reusable and extracted units for various pedagogical paradigms are described in Table 1.

2.2 SOA (Service-Oriented Architecture)

The composite computing model is an architecture that uses a distributed, discovery-based execution environment to expose and manage a collection of service-oriented software assets[9]. A software asset can be a piece of business logic, a component, a queue, or a single method that performs a useful function that you decide to expose

Table 1. Reusable units in pedagogical paradigms

Pedagogical Paradigm	Reusable Unit
tutorial, drill and practice	tutorial item, problem
case study method	case Example, discussion
problem-based learning	problem
exploratory learning	resource, discovery
resource-based learning	resource
goal-based learning	simulation

to the outside world.

SOA represents a way to achieve this composite computing model using the set of technologies that make up the Web service technology stack. This set of technologies currently consists of SOAP, WSDL, and UDDI, though other components may be added in the future. Fig. 1 shows the relationships among these technologies.

3. XML WEB SERVICES FOR A PEDAGOGICAL PARADIGM- BASED LIO OBJECTS

Under decentralized computing environments, a learning object needs to be reusable and interoperable in order to share and exchange contents between different educational systems. In this chapter, we will connect the reusable unit in pedagogical paradigms to an LIO object.

3.1 Relationship with LIO Objects and the Reusable Units in Pedagogical Paradigms

3.1.1 LIO Object

An LIO object is the least, reusable unit to transmit or track in e-learning systems which are conceptually grouping raw resources. Also, it is an learning object that are suitable for XML Web services. It has the characteristics of self-contained, reusability and aggregation. So, each LIO object can be consumed independently. It can be grouped into larger collections. And it could be transmitted to clients on Web as text data, image,

sound and other media data. An LIO object allows itself to have various types based on the analyzed, reusable unit in pedagogical paradigms. We designed the various types of LIO objects such as introduce, fact, quiz, try, link-more, tell-more and test objects according to the pedagogical paradigms. The introduce and fact objects could be seen as a tutorial item or a resource which is the reusable unit in pedagogical design which is composed by the actual body that the text represents introductions and facts and various related graphics. The quiz and test objects are applied as a problem in the pedagogically designed reusable unit. A quiz object is a simple, self-study question and a test object surveys the level of learning understanding. A try object is applied as case sample or simulation in the reusable unit and a link-more object is applied as a URL-based resource, which obtains more information to investigate, or to discover. A tell-more object could be applied as discussion in the reusable unit by allowing the discussion with experts or instructors.

Specially, we divide the LIO objects into two categories, the read LIO objects and the try LIO objects. This classification is based on learner interactivity. That is, the learner can read the tutorial contents or can learn by performing actual practice. Passive study of learner that acquires a knowledge by reading explained concept or fact in the virtual classroom is called the read LIO object and includes the types of the introduce and fact objects. The try LIO object requires interactive operation among learners and includes the try, quiz, link-more, tell-more and test objects. Table 2 shows the relationships of LIO elements and reusable units.

3.1.2 Lesson

A lesson element is a bundle of LIO objects. This element is composed of the content elements with specific learning objective in a related specific learning context. It includes not only a read LIO

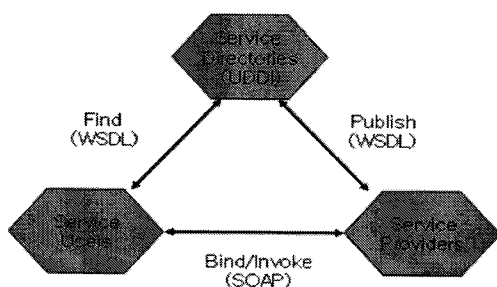

Fig. 1. Service-oriented architecture.

Table 2. Relationship with LIO elements and the reusable unit in pedagogical paradigm

LIO Kind	LIO Element	Reusable Unit in Pedagogy
Read LIO	Introduce	tutorial item
	Fact	tutorial item, resource
Try LIO	Try	case example, simulation
	Quiz	quiz-problem
	Test	test-problem
	Link-more	URL-based resource, discovery
	Tell-more	discussion, FAQ with instructor

object, a try LIO object, but also learning objective, pre-test, post-test and summary. An instruction designer should include following elements in their design:

- learning objectives - proposed goal for class action
- pre-test (optional) - to judge level of learner's knowledge before the lesson
- read LIO or try LIO object - actual learning activity
- summary - the record of learner's activity during the course or tutorial information for next level
- post-test (optional) - to judge pass or fail the learner.

Fig. 2 depict the structure of a lesson element in our learning object model.

3.2 Component Design for LIO Objects Modeling

In this section, we show an LIO component and

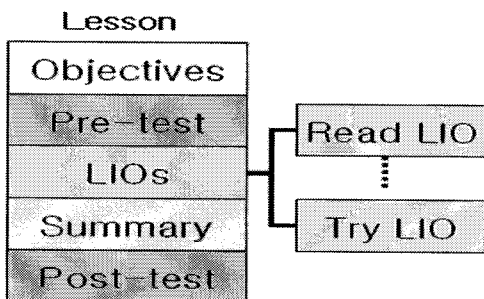

Fig. 2. Structure of lesson element.

its component connection interface.

3.2.1 LIO Component

Each LIO component may have attributes and methods according to the type of an LIO component. In their relation, let any possible LIO component generalize and design to upper abstract class. It is designed to the introduce class and the fact class for an introduce LIO and a fact LIO respectively. These classes are classified as the read LIO, due to no requirement of interaction with user. Also, the try, quiz, test, link-more and tell-more LIO objects are mapped to a try class, a quiz class, a test class, a link-more class and a tell-more class respectively. These classes are classified as the try LIO, due to the requirement of interaction with user. In order to freely handle these classes in application, we placed an id and a type attributes on most significant abstract class.

The LIO component could be identified by using GUID as content when they are served the lesson or course in package and described by XML-based metadata. In this paper, we have reference LOM for XML-based metadata. LOM is the standard proposal for third educational parties [10]. Fig. 3 depicts the hierarchy of the LIO classes.

3.2.2 LIO Object's Component Connection Interface

Each LIO with metadata is stored in the object storage, i.e., storage for contents and metadata to share and retrieve among applications and stored with the item of lesson unit to be reused[11]. In a lesson, we allow each LIO of learning contents to approach with located URL and metadata's location. XML schema on Fig. 4 are used to allocate each LIO at learning contents. This is used to allocate LIO object when we design the database.

Fig. 5 depicts the file structure that is packaged with course contents. This structure is designed for efficient XML Web services in mind and consists of a manifest file and many physical files.

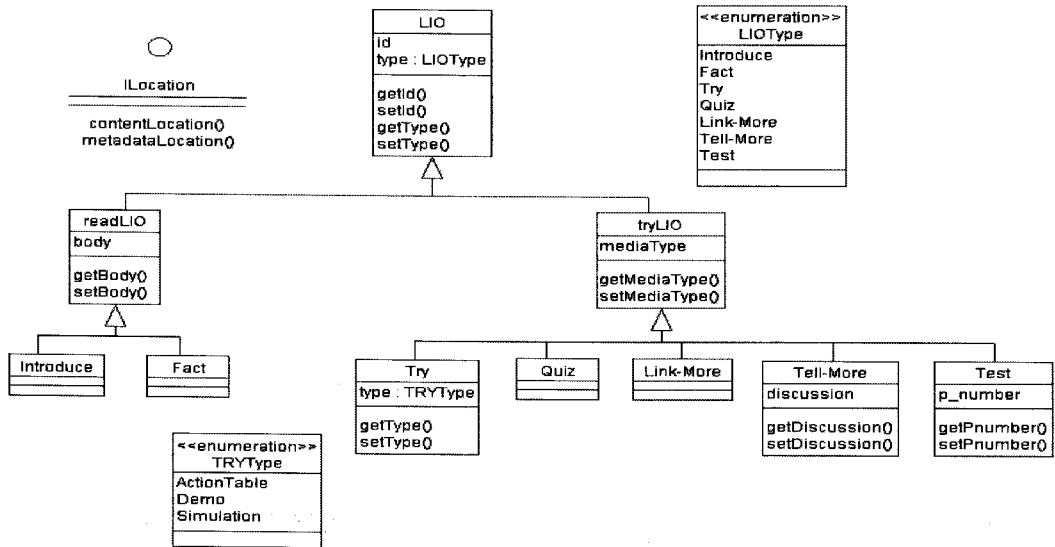

Fig. 3. Hierarchy of LIO classes.

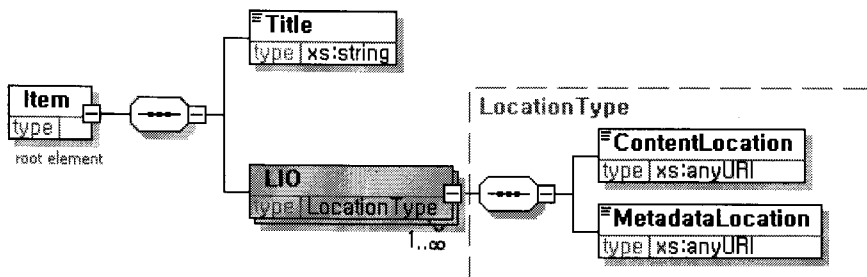

Fig. 4. XML schema for lesson unit.

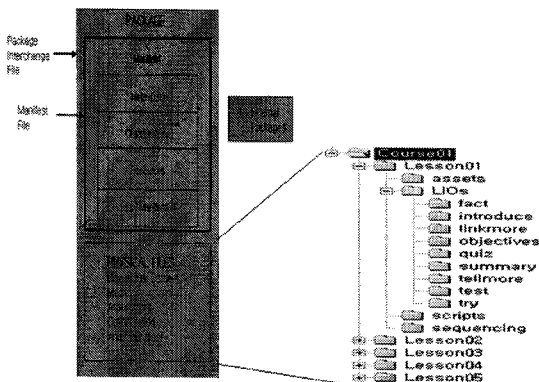

Fig. 5. File structure packaged with course contents.

Each typed LIO objects are stored in metadata along with the information for a content location. Each LIO object is designed with components and exposes to interfaces for XML Web services.

3.3 A Flow for XML Web Service with LIO Objects

For active transmission of learning contents, we may describe the operation flow of learning Web service as follows:

1. The learning contents provider registers a provider's information and contents service information (WSDL file) to UDDI directory.
2. Any learner or instruction designer who uses client application searches and finds the desired contents services on UDDI directory. Learner or designer can trace how to called to the desired services through service detail (WSDL).
3. The client application of learner or instruction designer can receive the message and the re-

sult value of the requiring contents services through SOAP.

Fig. 6 shows the extended figure of such processing flows to support the system structure of XML Web services for learning contents. Web service system means the runtime environment of Web service. And in the JVM, it means the SOAP engine that is included in the servlet container. It processes the requested SOAP from client applications which are used by learner or instruction designer, or mapped to other requests into native components. And at same time, it returns the result from the component to a client application in the SOAP form. Then, Web server takes a role of intermediary to transfer Web Service request which

is received through HTTP to Web service run-time system and the service interface could be known by using WSDL file.

3.4 Client for XML Web Service with LIO Objects

A Web client application utilizes a Web service on Internet. From the Web browser, it obtains an LIO object catalog and places it to a shopping cart. Then after checking the shopping cart, learner or instruction designer could download the selected contents URL after selecting the required LIO object for the learning contents. Fig. 7 shows the LIO catalog interface for LIO objects.

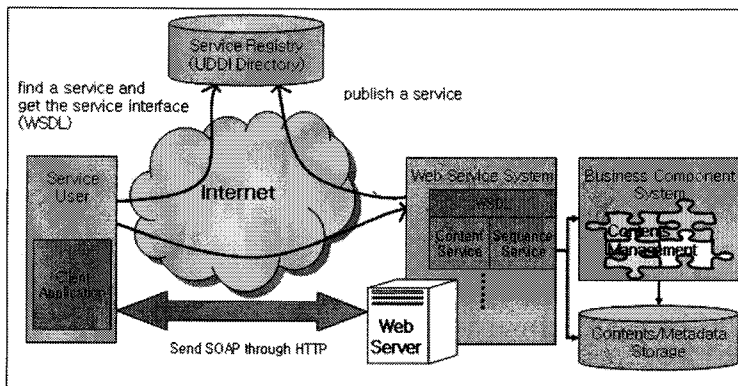

Fig. 6. Architecture for LIO objects.

A Lesson Item - LIO Catalog - Microsoft Internet Explorer

주소 http://localhost:7001/LearningContentsWebApp/liocatalog

Lesson Item 1 LIOs Catalog

TITLE	KEYWORDS	LIO CLASS	LIO TYPE	LEARNING DIFFICULTY	DISCRIPTIONS	ADD CART
UML fact	class, workflow model	readLIO	fact	easy	fact	ADD
UML introduction	unified modeling language	readLIO	introduce	easy	introduce	ADD
UML linkmore	http://adm.omg.org	tryLIO	linkmore	middle	linkmore	ADD
UML quiz	quiz1, quiz2	tryLIO	quiz	middle	quiz	ADD
UML tellmore	professor Kim website	tryLIO	tellmore	middle	tellmore	ADD
UML test	teat1, test2	tryLIO	test	middle	test	ADD
UML try	Simul1, ActionTable2	tryLIO	try	easy	try	ADD

ORDER LIO VIEW

Fig. 7. Client catalog interface for LIO objects.

3.5 Comparisons

A learning object model can be compared in many different perspectives. Table 3 compares our learning object model with other learning object models such as AICC, IDC and SCORM. First, in respect to educational perspectives we compared our model with others in instructional unit support and easy course reorganization.

Next, in respect to technical perspectives we compared our model with others in XML metadata support, reusability, mutual operability and accessibility. As our LIO learning object model is based on an XML Web service, it has good accessibility as compared to other models. An LIO learning object has the characteristic of self-contained, reusability and aggregation. So, the LIO object model has the instructional unit support and easy course reorganization. Also the LIO object can be grouped into larger collections.

4. CONCLUSIONS

In this paper we developed the sharable and reusable learning objects which were suitable for XML Web services. These LIO objects are extracted from the principles of pedagogical paradigms for reusable learning units.

Table 3. The Comparison of our LIO model and other learning object models

model comparison item	AICC	IDC	SCORM	Proposed LIO Model
instructional unit support	○	△	×	○
easy course reorganization	△	△	×	○
XML metadata support	×	○	○	○
reusability	×	○	○	○
mutual operability	×	○	○	△
accessibility	×	×	×	○

We has designed the LIO learning object with component-based development method by using reusable units that are based on various pedagogical paradigms. These designed objects could be reused and shared among different kinds of e-learning systems under decentralized environment and these learning units could be transmitted and tracked in the Web. Existing models, such as Web-hosted and ASP-oriented service model, are difficult to cooperate and integrate among the different kinds of education systems. So we developed the LIO objects that is suitable for XML Web services.

The LIO learning objects which are based on pedagogical paradigm for an XML Web service have several advantages. First, as our LIO object model is based on an XML Web service, it has good accessibility as compared to other learning object models. Second, in the educational perspective a learner or an instruction designer could quickly reformulate the course according to frequent changes in the learning environment. This is more prominent when the boundary of learning is clearly shown. Third, an educational institution which needs to build e-learning system for decentralized environment could observe changes in business world and cooperate with outside education service to reduce the time for system development and integration. Finally, the extensibility of e-learning systems could be increased by extending the reusable unit of software to the level of application.

REFERENCES

- [1] IEEE Learning Technology Standards Committee, "Standard for Data Model for Content Object Communication," <http://ltsc.ieee.org/wg11>, 2003.
- [2] Michael Brennan, Susan Funke, and Cusbing Anderson, "The Learning Content Management Systems: A New eLearning Market Segment

- Emerges," *An IDC White Paper*, 2001.
- [3] Advanced Distributed Learning Initiative, "The SCORM Overview and The SCORM Content Aggregation Model," <http://www.ADLnet.org>, 2002.
- [4] IMS Global Learning Consortium, Inc., "IMS Question & Test Interoperability Information Model Specification (Version1.1)," *IMS Global Learning Consortium, Inc.*, 2005.
- [5] D. Frosch-Wilke, "An Extended and Adaptable Information Model for Learning Objects," *Proceedings of the IEEE International Conferences on Advanced Learning Technologies*, pp. 166-170, Aug. 2004.
- [6] B.K. Daniel and P. Mohan, "A Model for Evaluating Learning Objects," *Proceedings of the IEEE International Conferences on Advanced Learning Technologies*, pp. 56-60. Aug. 2004.
- [7] N. Pukkhem and W. Vatanawood, "Instructional Design using Component-based Development and Learning Object Classification," *Proceedings of the Fifth IEEE International Conferences on Advanced Learning Technologies*, pp. 492-494, July 2005.
- [8] Albert Ip and Iain Morrison, "Learning Objects in Different Pedagogical Paradigms," [http://users.tpg.com.au/adslfrcf/lo/LO\(ASCILITE2001\).pdf](http://users.tpg.com.au/adslfrcf/lo/LO(ASCILITE2001).pdf), 2001.
- [9] David A. Chappel, and Tyler Jewell, *Java Web Services: Using Java in Service-Oriented Architecture*, O'REILLY, 2002.
- [10] IEEE Learning Technology Standards Committee, Standard for Information Technology- Education and Training Systems -

Learning Objects Metadata, 2002.

- [11] A. R Silva and P.C.D.D. Silva, "Design Experiences with the Learning Objects Board System," *Proceedings of the 40th Hawaii International Conferences on System Sciences*, pp. 1-10, Jan. 2007.



Haeng-ja Shin

She received the B.S., M.S. and Ph.D. degrees in Computer Engineering from Dong-A University, Korea in 1991, 1995 and 2005 respectively. In 2005, she was a BK21-fund scholar at Division of Electrical, Electronic, and Computer Engineering in Dong-A University. She is currently a researcher of Engineering Education Center at Dong-A University. Her research interests include Web Services System and Web-based Education.



Kyung-hwan Park

He received the B.S. degree in computer engineering from Kyungpook National University, in 1981 and M.S. and Ph.D. degrees in computer engineering from Seoul National University, in 1983 and 1990 respectively. In 1998, he was a visiting scholar at University of California, Irvine. Since 1987, he has been a professor of computer engineering at Dong-A University. His research interests include Multimedia Systems, Distance Education and Computer Graphics.