

A New Algorithm to Calculate the Optimal Inclination Angle for Filling of Plunge-milling

Hamdy Tawfik¹

Technology Development Branch, Specialized Studies Academy, Workers' University, Egypt.

Abstract

Plunge milling is the fastest way to mill away large volumes of metal in the axial direction. The residual volume (inaccessible volume by the plungers) is minimized when selecting a specific direction of filling. This direction is known as the optimal inclination angle for filling of the plunged area. This paper proposes a new algorithm to calculate the optimal inclination angle of filling and to fill the plunged area with multi-plungers sizes. The proposed algorithm uses the geometry of the 2D area of the shape that being cutting to estimate the optimal inclination angle of filling. It is found that, the optimal inclination angle for filling of the plunged area is the same direction as the longer width of the equivalent convex polygon of the boundary contour. The results of the tested examples show that, the residual volume is minimized when comparing the proposed algorithm with the previous method.

Key Words : Plunge-milling, Plungers, Optimal Inclination Angle, Residual Volume, Equivalent Convex Polygon.

1. Introduction

Plunge (axial) milling is the same action as drilling, but using a center cutting end mill instead of a drill bit, Fig. 1. The cutting process is a very secure and productive way to remove large volumes of metal with long tools. Moreover, the cutting forces are aligned with the cutter/spindle axis and are smaller than typical side forces generated during end milling. Plunge milling offers a way to mill deep pockets productively without the need for high speed machining. An older machining center may be slow, but as long as the machine is fairly rigid, it can potentially achieve a high metal removal rate by roughing out material in a series of overlapping plunges with a long tool. These plunges are straight Z-axis moves into the work, similar to drilling moves. Certain milling cutters are designed to be effective at cutting by this way. These cutters are known as plungers and classified into two types, side and center plungers [1], Fig. 2. In the center plunger, one of the cutting edges on the end of the plunger extends across the center of the plunger so that there is a cutting edge for the full diameter of the end of plunger, Fig. 2-a. Side plunger or non-center cutting plungers have cutting edges on the end, but they do not extend to the center. These plungers will cut on the end and can be used for slotting and surfacing, Fig. 2-b.

In both these types' plungers, the tool plunges axially into the workpiece. Plunge depth is either to Z (bottom)

level or to the selected surface(s). The tool retracts to the Z (top) level and moves to the clear Z level. It then

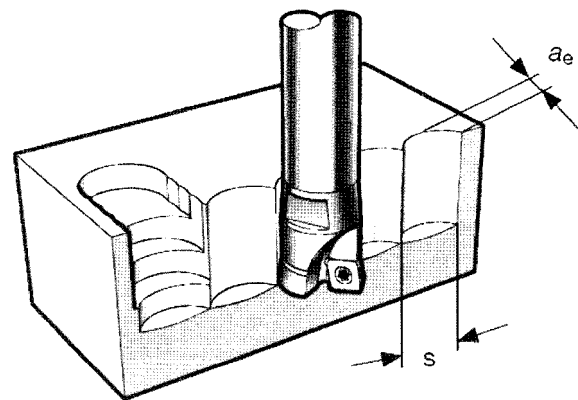

Fig. 1. Plunge-milling cutting process.

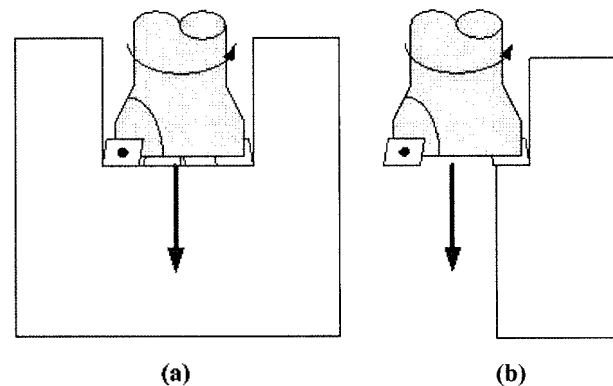

Fig. 2. Plunge-milling cutters. (a) Center plunger, (b) Side plunger.

*Corresponding author:
Tel: +20104552311
Fax: +20502345293
E-mail: tawfikhtm@gawab.com

moves to the next XY position at side step “S” (Fig. 1) and/or forward step “a_c” (as shown in Fig. 1) predefined values.

The tool ends the cycle by plunging repeatedly in an overlapping pattern until the entire part is roughed. The plunging area boundary is defined either by the previous stock contour or by user-defined contour(s).

Most of the current developing trends in the plunge milling are found in the commercial CAD/CAM softwares [2-4]. These commercial softwares use only one cutting tool to plunge the cutting area. The using of only one cutting tool to plunge the cutting area is a time consuming, and maximizes the inaccessible residual volume. El-Midany et al. [5] present a new method called “Ocfill” for optimizing the selection of multi-plungers sizes and toolpoint path. The Ocfill method is used to fill 2D area with a number of overlapped circles with multi-diameters. The 2D area is expressed as a plunged area and the circles are known as the plunged holes. Although Ocfill method enhanced the filling of plunged area, the direction of inclination angle of filling is always selected to be constant and parallel to zero direction.

The objective of the present research is to use the characteristics of the geometry to estimate the optimal direction of filling. A new algorithm is proposed to calculate this optimal direction and generates plunge-milling toolpoint path according to this direction.

2. Proposed Algorithm to Calculate Optimal Inclination Angle of Filling

The proposed algorithm to calculate optimal inclination angle of filling consists of two steps, (1) constructing of the equivalent convex polygon of the boundary contour and (2) calculate the direction of the longer width of the equivalent convex polygon.

From many applications workpieces, it is found that the direction of the longer width of the equivalent convex polygon is used to locate the maximum area of the overlapped circles (plunged holes); i.e. the area scanned by plungers are maximized. And, the residual volume (inaccessible volume by the plungers) is minimized. So, this direction ensures the optimal direction of filling of plunge-milling.

2.1 Construct the Equivalent Convex Polygon of the Boundary Contour

A planar polygon is convex, if it contains all the line segments connecting any pair of its vertices [6]. Moreover, no side extended cuts any other side or vertex. The convex polygon can be cut by a line in at most two points, Fig. 3.

If the boundary polygon of the plunged area is a convex polygon, it will be used directly to calculate optimal inclination angle of filling. The boundary polygon may be a concave polygon; in this case, the equi-

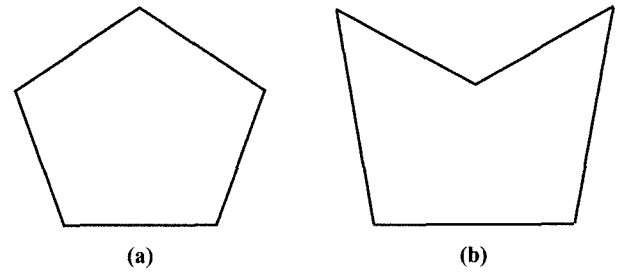

Fig. 3. Convex and Concave Polygons. (a) Convex polygon, (b) Concave polygon [7].

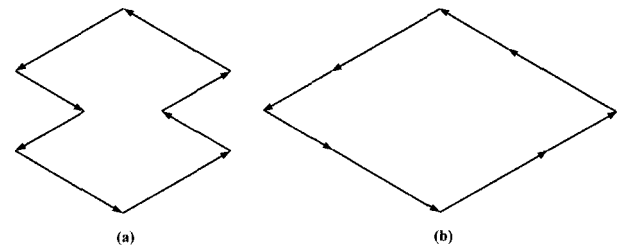

Fig. 4. Equivalent convex polygon. (a) Concave boundary polygon, (b) Equivalent convex polygon of boundary polygon.

valent convex polygon of the boundary polygon must be generated, Fig. 4.

To construct the equivalent convex polygon of the concave boundary polygon, the following steps is needed, Fig. 5:

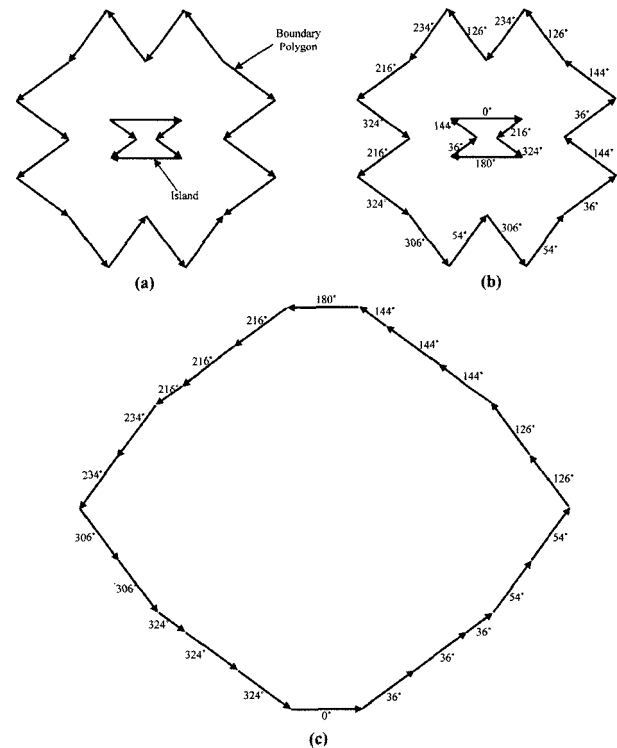

Fig. 5. Construction of equivalent convex polygon. (a) Concave polygon, (b) CCW boundary and CW island with entity angle (unsorted angles), (d) Construction of equivalent convex polygon from sorted (based on entity angle) entities.

- 1- Change the direction of the boundary polygon to be in CCW (Counter Clockwise) direction and all inner islands in CW (Clockwise) direction.
- 2- Re-sort boundary polygon and inner island entities according to its angles in ascending order.
- 3- Construct a planner polygon from the sorted entities.
- 4- The generated planner polygon is always convex and known as an equivalent convex polygon.
- 5- The equivalent convex polygon will be a closed polygon whatever the complexity of boundary polygon and containing islands, if the boundary polygon was closed.

2.2 Calculate the direction of the longer width of the equivalent convex polygon

The width of a convex polygon at a specific direction is defined as the maximum distance between parallel lines of support, Fig. 6. This definition already hints at the characteristics of the width. However, a convex polygon admits parallel lines of support in any direction, and for each direction, the width is (usually) different. Fortunately, not every direction needs to be checked. From the characteristics of the convex polygon, the longer width in a specific direction occurs for the parallel line that will not intersect the convex polygon, Fig. 6-a.

An algorithm to calculate width of convex polygon can be used to go through the antipodal pairs list of the polygon, determine the vertex-edge pairs, and compute the longer width and its direction from that. The algorithm would be:

- 1- Select an edge and define it as the support.
- 2- Make the parallel lines of support that pass through polygon edges, Fig. 6-a.
- 3- Compute the widths (distances between the parallel lines and support), and keep the longer width (the distance between support and parallel line that will not intersect the polygon) as the maximum width and its direction.
- 4- Select another edge, repeat steps 1-3, and compute the new width in that direction, compare to old maximum width, and update if necessary.
- 5- Output the maximum width and its direction.

The direction of the maximum width of convex polygon is then used to construct plunge-milling toolpoint path.

3. Construct the Toolpoint Path of Plunge-milling

A new method to fill the plunged area is proposed. This method uses the concepts of quadtree method [8-9]. A quadtree is a two dimensions concept similar to the octree method [10] to approximate the plunged area

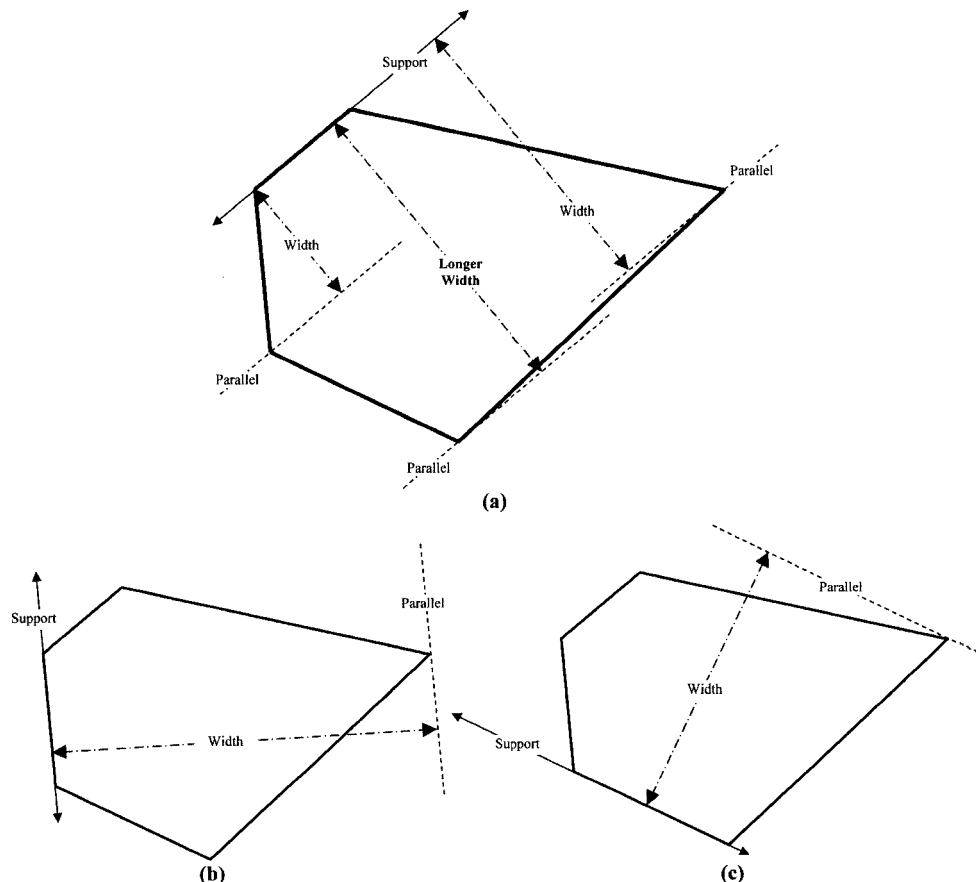

Fig. 6. Width of convex polygon. (a) Construct support and parallel lines, (b) and (c) Width of convex polygon in different directions.

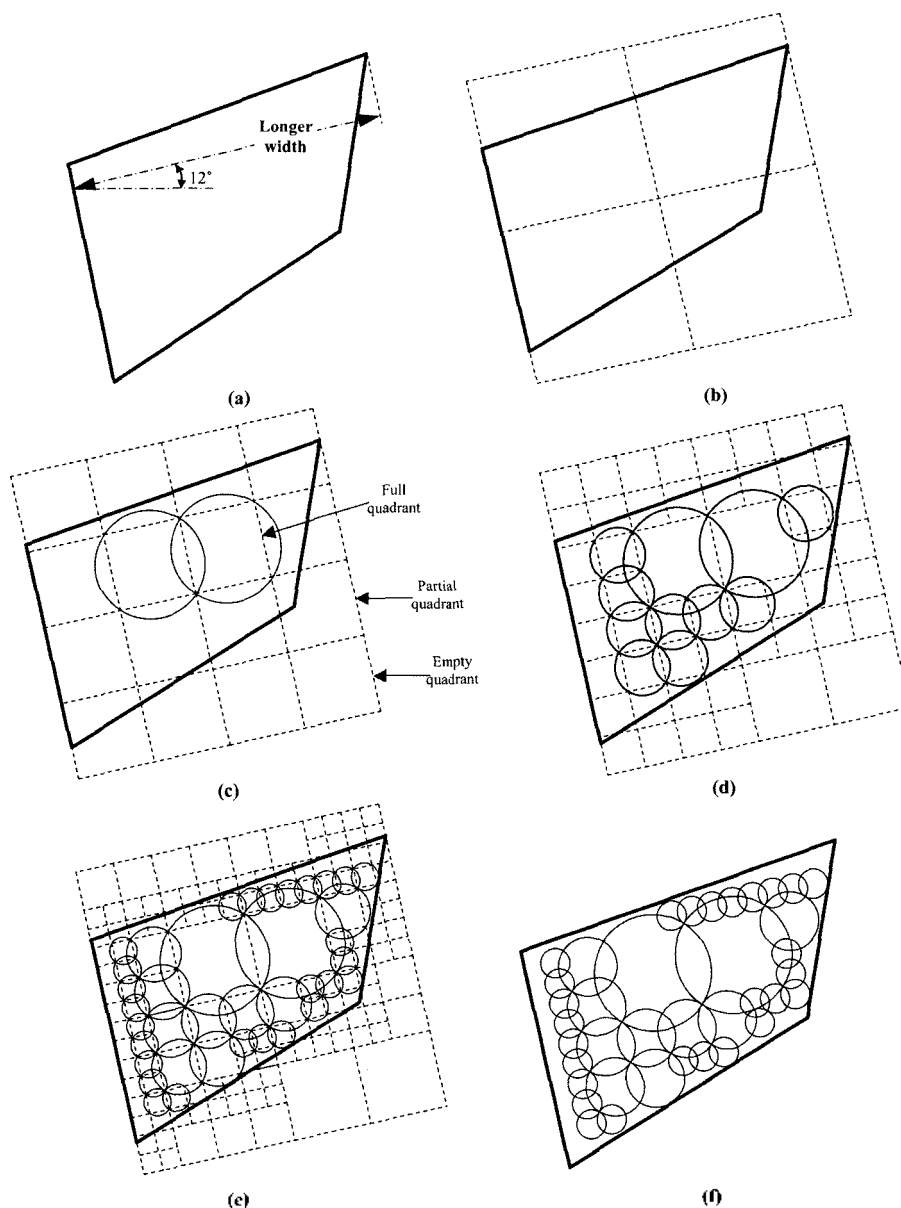

Fig. 7. Proposed method to fill the plunged area (Continued). (e) 4th step of splitting enclosed square, (f) Plunge-milling toolpoint path with the desired resolutions. (Three plungers)

with a group of squares (quadrants) of different sizes. These quadrants constructs according to the optimal direction of filling that calculated from the previous section. Fig. 7 shows the procedure of filling that start with making the enclosed square parallel to the optimal direction. This square is divided into four quadrants (squares) and these quadrants are checked with the boundary contour. There are three cases for this check, (1) the quadrant found inside the boundary contour (full quadrant), (2) the quadrant found outside the boundary contour (empty quadrant), and (3) the quadrant intersects the boundary contour (partial quadrant), Fig. 7-c.

The full quadrants are prepared to construct the enclosed circles. If the enclosed circle of the full quadrant intersects the boundary contour, this full quadrant changes to partial quadrant, otherwise, the

enclosed circle adds to the toolpoint path. The empty quadrants are removed and not used for any later check. The partial quadrant is split into four quadrant and checked with the boundary contour and the procedure goes on until the desired resolution. Fig. 7. Proposed method to fill the plunged area (to be continued).

4. Comparing of Proposed and Previous Methods

When the proposed method compared with the previous method (Ocfill method) [5], the volume that

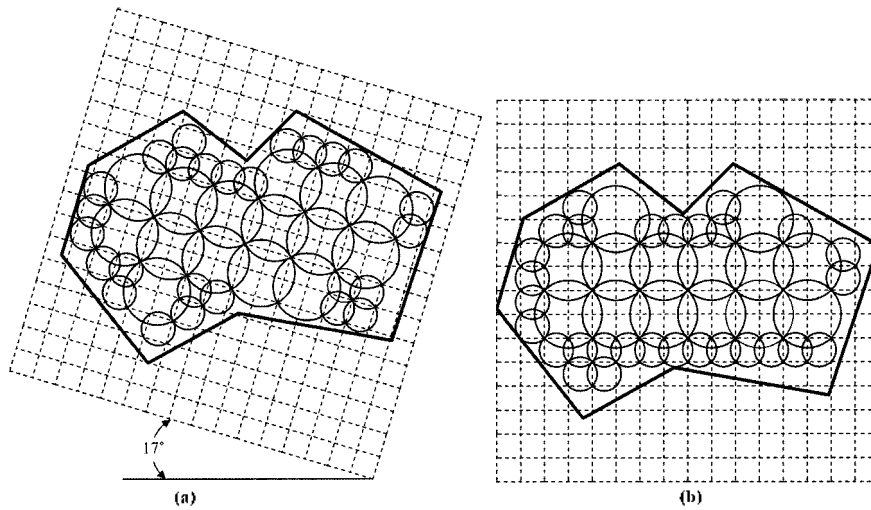

Fig. 8. Comparison of proposed and previous methods. (a) Proposed method (Angle of filling =163, Accessible Volume: 10433.6470), (b) Previous method. (Angle of filling =0.0, Accessible Volume: 10219.0871)

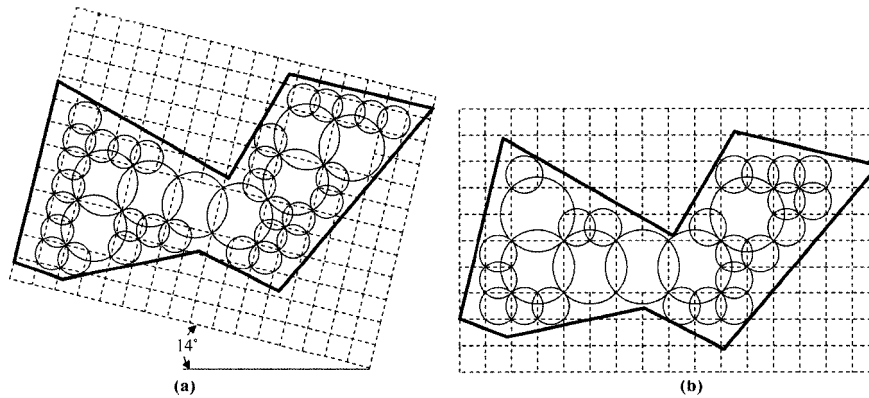

Fig. 9. Comparison of proposed and previous methods. (a) Proposed method (Angle of filling =166, Accessible Volume: 31046.9384), (b) Previous method. (Angle of filling =0.0, Accessible Volume: 29893.6671)

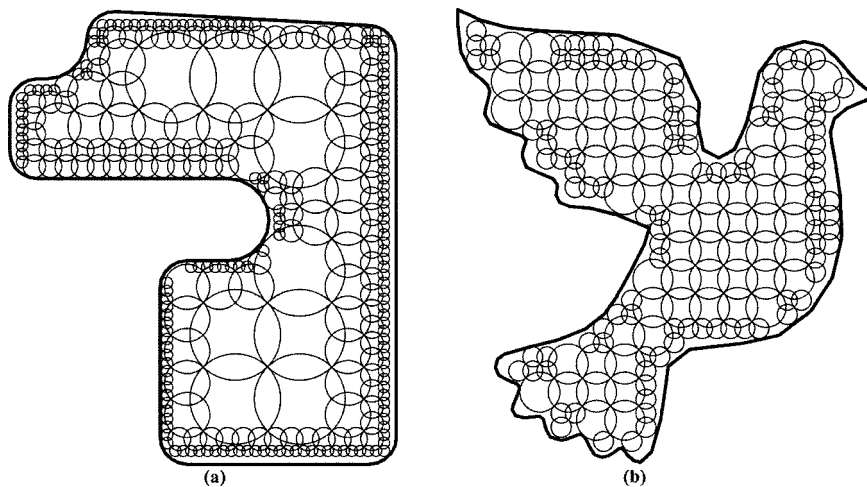

Fig. 10. Application Examples. (a) Angle of filling = 122.767°, (b) Angle of filling = 112.021°.

will be accessible by the plungers is maximized with a significant value, Figs. 8, 9. The locations of holes (plungers' diameters) across the plunged area are also uniformly distributed.

5. Applications

Many applications' examples are used to verify robustness, quickness and the stability of the proposed

method to fill the plunged area. Fig. 10 shows two applications' examples, the first one has an optimal inclination angle = 122.767° and the second application example has an optimal inclination angle of filling = 112.021° .

6. Conclusion

The paper presented a new algorithm to calculate the optimal direction for filling of plunge-milling based on the geometry of the plunged area. This direction was found that, parallel to the direction of longer width of the equivalent convex polygon of the boundary contour. Based on the calculated optimal inclination angle for filling, the toolpoint path of plunge-milling is constructed.

The comparing of the proposed and the previous methods verified that the accessible area is maximized by a significant value.

References

[1] "High productive milling", User's Guide, Sandvik Coromant, (2006), www.coromant.sandvik.com.

- [2] MasterCAM® CAD/CAM Software, (2006), <http://www.mastercam.com/>.
- [3] Delcam-CAD/CAM Software Creators, (2006), <http://www.delcam.com/>.
- [4] TekSot CAD/CAM Software, (2006), <http://www.teksoft.com>.
- [5] El-Midany T. T., Elkeran A., and Tawfik H., (2006), "Optimal CNC Plunger Selection and Toolpoint Generation for Roughing Sculptured Surfaces Cavity," Accepted for Publication in *ASME, J. of Manufacturing Science and Engineering*.
- [6] Eric W. Weisstein, (2006), "Convex Polygon," From MathWorld A Wolfram Web Resource. <http://mathworld.wolfram.com/ConvexPolygon.html>.
- [7] Eric W. Weisstein, (2006), "Concave Polygon," From MathWorld A Wolfram Web Resource. <http://mathworld.wolfram.com/ConcavePolygon.html>.
- [8] Gargantini I., (1982), "An effective way to represent quadrees," *ACM*, Vol. 25, Issue 12, pp. 905-910.
- [9] Sarah F. Frisken and Ronald N. Perry, (2002), "Simple and efficient traversal methods for quadrees and octrees," *Journal of Graphics Tools*, 7(3), pp. 1-11.
- [10] Samet H., Kochut A., (2002), "Octree approximation and compression methods," *3DPVT, First International Symposium on 3D Data Processing Visualization and Transmission (3DPVT'02)*, pp. 460-469.

Hamdy Tawfik was born in 1971 in Egypt. He is currently a lecturer in Workers' University, Mansoura, Egypt. He received his B.Sc., M.Sc., and Ph.D degrees from the Department of Production Engineering and Mechanical Design at Mansoura University/Egypt in 1994, 1999, and 2003 respectively. His research interests include geometric algorithms in CAD/CAM, CNC toolpath planning, sculptured surface CNC machining, representation of freeform shapes through NURBS, EDM, Small-Hole EDM-Drilling, Wire-EDM, and plunge-milling. He can be reached via E-mail at: tawfikhtm@gawab.com



Hamdy Tawfik