

Analysis of the Induction Heating for Moving Inductor Coil

J. O. Yun, Young-Soo Yang*

*Department of Mechanical Engineering, College of Engineering, Chonnam National University,
300 Yongbong-dong, Gwangju 500-757, Korea*

Induction heating is a process that is accompanied with magnetic and thermal situation. This paper presents a simulation of a magneto-thermal coupled problem of an induction heating process for moving inductor coil. In the magnetic and thermal analyses, temperature-dependent magnetic and thermal material properties were considered. As the inductor coil moves in the process, solution domains corresponding to inductor changes into those of the air, and the solution domains of air change into those of the inductor. For these reasons, modeling of induction heating process is very difficult with general purpose commercial programs. In this paper, induction heating process for moving coil was simulated with the concept of traveling the position of the heating planes. Finite element program was developed and finite element results were compared with the experimental results.

Key Words : Moving Inductor, Induction Heating, Finite Element Method

1. Introduction

Induction heating process is used in the steel making process. It is often used for surface hardening, tempering and straightening of deformed steel plates. Because induction heating is a complex process, its feasibility for new application often relies on experiments. But these experiments do not provide a great deal of general information about the process. In engineering point of view, it is important to investigate the temperature distribution of the steel plate with the induction heating process. To analyze the induction heating process by numerical method, the coupled magnetic and thermal problem must be solved, because most of the material properties in the induction heating depend on the temperature (Nerg et al., 2000). Meanwhile, in most induction heating processes, the inductor coil moves to cover a

wide range. But so far, most analyses related to the induction heating have assumed that the position of the inductor does not change during the heating process without considering the case in which the inductor moves (Garbulsky et al., 1997; Gong et al., 1995; Chaboudez et al., 1997; Sadeghipour et al., 1996). In this research, a finite element program was developed to analyze the electro-magnetic field and temperature distribution of the induction heating for moving inductor. The finite element program was developed by using FORTRAN language. In the simulation of the induction heating process, solution domain consists of inductor, air and steel plate. As the inductor moves, the space where coil exists is changed into that of air zone in the transient analysis of the induction heating process. Then, the solution domains of the inductor are changed into those of air with the time step. Also the air zone in which the coil moves is changed into the inductor zone, and the position at which the current flows varies with the time step. In other words, the material properties of the inductor are changed into those of air, and the position at which the current flows is varied with the time step. Therefore, the above procedure must be

* Corresponding Author,

E-mail : ysyang@chonnam.ac.kr

TEL : +82-62-530-1675; FAX : +82-62-530-1689

Department of Mechanical Engineering, College of Engineering, Chonnam National University, 300 Yongbong-dong, Gwangju 500-757, Korea. (Manuscript Received January 27, 2006; Revised May 23, 2006)

repeated manually at each time step. This reason makes the numerical analysis using general purpose commercial programs very difficult.

In this paper, a simulation method for the induction heating process with moving inductor coil is suggested. In order to analyze the electro-magnetic field, the zone corresponding to inductor coil was divided into finite numbers of planes which are two dimensional solution domains. For each plane, two dimensional finite element analyses for electro-magnetic field were performed. In the three dimensional temperature analysis, the eddy current calculated from the two dimensional electro-magnetic analysis was used heat source. By moving the heating planes, the finite element analysis with the variation of the coil position was carried out. In order to verify the numerical calculations, the results of the finite element analysis were compared with the experimental results.

2. Finite Element Formulations

2.1 Analysis of electro-magnetic field

The governing equations derived from Maxwell's equation to describe eddy currents can be written as follows (Sadeghipour et al., 1996)

$$-\frac{1}{\mu}\nabla^2 A + j\omega\sigma A = J_s \quad (1)$$

where A is the magnetic vector potential, J_s the current density, j the square root of minus unity, μ the permeability, ω the angular frequency and σ the electric conductivity. The finite element formulation obtained from the governing equation is as

$$[K]\{A\} = \{J\} \quad (2)$$

where

$$[K] = \int \left(\frac{1}{\mu} \left[\frac{\partial N}{\partial x} \right]^T \left[\frac{\partial N}{\partial x} \right] + \frac{1}{\mu} \left[\frac{\partial N}{\partial y} \right]^T \left[\frac{\partial N}{\partial y} \right] \right) dx dy + j\omega\sigma \int [N]^T [N] dx dy \quad (3)$$

$$\{J\} = \int J_s [N]^T dx dy \quad (4)$$

Magnetic vector potential can be evaluated from above equation, and the eddy current can be cal-

culated by using the magnetic vector potential and is given by

$$J_e = \sigma E = -j\omega\sigma A \quad (5)$$

where E is the electric field intensity and J_e is the eddy current density. Heat source is expressed as

$$q = \frac{[\text{Re}(J_e)]^2}{\sigma} \quad (6)$$

where, q is the heat source.

For the special case where the source current density is assumed to be time harmonic, the heat input for the average time can be written as

$$\bar{q} = \frac{1}{2} \omega^2 \sigma A^* A \quad (7)$$

where, \bar{q} is the heat input for the average time and $*$ is the complex conjugate.

2.2 Analysis of temperature distribution

From the heat diffusion equation for the case of induction heating, the governing equation is expressed as (Wu et al., 1988)

$$\rho c \frac{\partial T}{\partial t} = \nabla \cdot (k \nabla T) + \bar{q} \quad (8)$$

boundary conditions are given as

$$-k \frac{\partial T}{\partial n} = h_c (T - T_\infty) \quad (9)$$

When the finite element formulation is employed and boundary conditions are applied, the equation (8) can be written as follows (Huebner et al., 1995; Masubuchi, 1980)

$$[C]\{\dot{T}\} + [K]\{T\} = \{Q\} \quad (10)$$

here

$$[C] = \int \rho c [N]^T [N] dV \quad (11)$$

$$[K] = \int \left(\left[\frac{\partial N}{\partial x} \right]^T [k] \left[\frac{\partial N}{\partial x} \right] + \left[\frac{\partial N}{\partial y} \right]^T [k] \left[\frac{\partial N}{\partial y} \right] + \left[\frac{\partial N}{\partial z} \right]^T [k] \left[\frac{\partial N}{\partial z} \right] \right) dV + h_c \int [N]^T [N] d\Gamma \quad (12)$$

$$\{Q\} = \int \bar{q} [N]^T dV + \int h_c T_\infty d\Gamma \quad (13)$$

where T is temperature, ρ the density, c specific heat, k conduction coefficient and h_c convection

coefficient. \dot{T} and T are calculated using θ as

$$\dot{T} = \frac{T_{t+\Delta t} - T_t}{\Delta t} \quad (14)$$

$$T = (1 - \theta) T_t + \theta T_{t+\Delta t} \quad (15)$$

In our calculation, θ was set to 1. To properly use the available capability of the program for the temperature-dependent induction heating problem, the variations of the material properties according to temperature were considered (Enokizono et al., 1995). In the analysis of the electro-magnetic field, σ and μ were defined with respect to temperature. And \bar{q} was calculated by using σ , which was changed with temperature, and also, c and k were functions of their corresponding temperature. Schematic diagram of induction heating

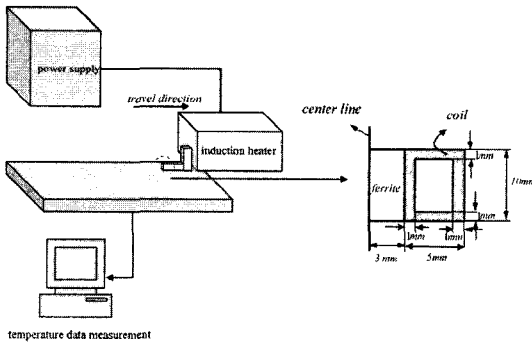

Fig. 1 Schematic diagram of induction heating process and half coil shape

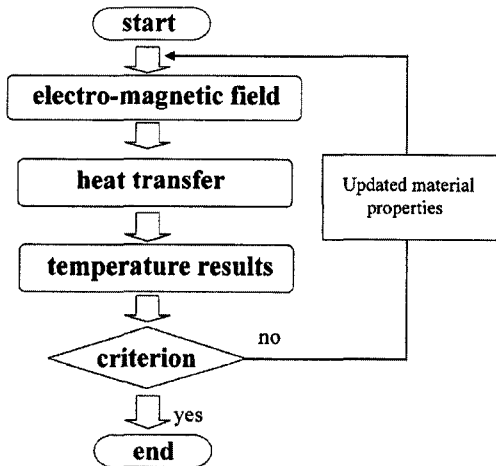

Fig. 2 Simulation procedure flow chart

process is shown in Fig. 1, and coupling procedure between the electro-magnetic and thermal analysis is shown in Fig. 2.

3. Finite Element Results and Experiments

Figure 3 shows the induction heating process in the experiment. Thermocouples were attached to the center of the bottom surface of the specimen. Schematic half diagram for the finite element analysis are shown Fig. 4. To analyze the two dimensional electro-magnetism, a mesh generation, as shown in Fig. 5, was applied. Solution domain contains the air zone and steel plate. The frequency of induction heating system was 50 kHz, travel velocity was 6 mm s^{-1} and the current was 800A, which were the same as the experi-

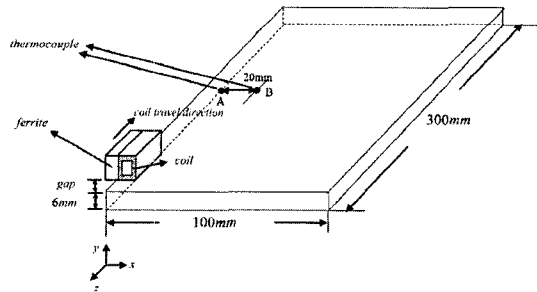

Fig. 3 Schematic half diagram for experiment

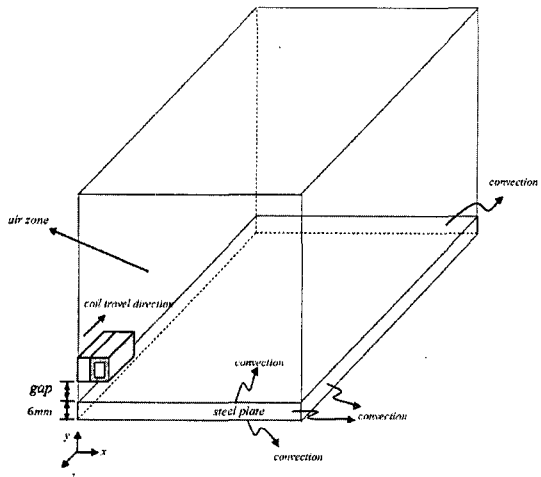
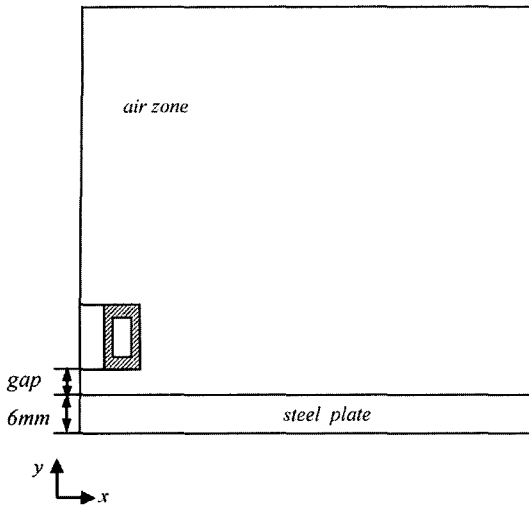
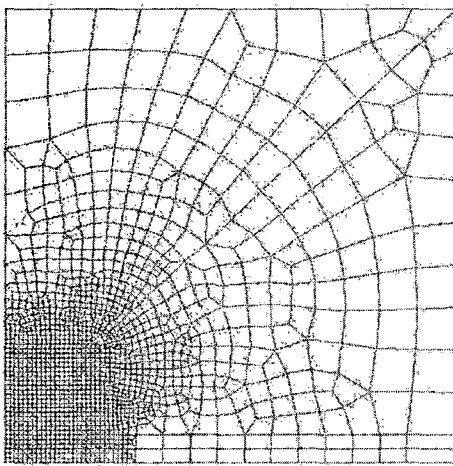

Fig. 4 Schematic half diagram and boundary conditions for FEM



(a) Solution domains



(b) Mesh generations

Fig. 5 Solution domains and mesh generations for 2-d electro-magnetic analysis

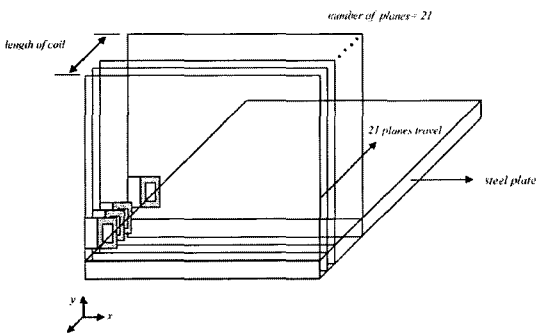

Fig. 6 Modeling of moving heat source using movement of heating planes

mental conditions. Because of the symmetry of the problem, half of the model was simulated. Fig. 6 shows the modeling of moving heat source. The zone corresponding to the length of inductor coil is divided into 21 to obtain the velocity of 6 mm s^{-1} . It is assumed that electro-magnetic distribution is equal for each plane in the direction of coil travel. But for each plane, nonlinear electro-magnetic analysis depending on temperature is considered. In the direction of coil travel, the temperature distribution of the electro-magnetic solution domain for the each plane is different. For each plane, by performing the analysis of the electro-magnetic field depending on temperature, nonlinear electro-magnetic analysis which is dependent on temperature can be considered for the direction of coil travel. Generally, heat generation is large at the area where temperature is low because electric conductivity is large. Therefore, it is predicted that front plane for the direction of coil travel contains large heat generation and the plane which is located at the high temperature region contains small heat generation. For each plane, two dimensional electro-magnetic analysis was performed and the eddy current which was calculated was used heat source. By moving 21 planes which have heat source, the finite element analysis considering the movement of the inductor coil was performed. The cross-section of the coil is shown in Fig. 1. The width of the coil shape in Fig. 1 was 5 mm, height was 10 mm and air gap was 1 mm in the experiment. And the length of coil in the z-direction was 60 mm. The finite element analysis and the experiment were performed at the same condition. The steel plate, which includes the thermocouples, was cut, and the heat affect zone was inspected. The boundary condition used for the analysis of magnetic field in the symmetry axis was the assumption that the magnetic vector potential was zero. Fig. 7 shows the analysis of the electro-magnetic field at ambient temperature. Large magnetic vector potentials were concentrated on the coil zone. Inside the steel plate, magnetic vector potentials were small due to the skin effect. Three dimensional model for temperature analysis is shown in Fig. 8. Fig. 9 shows the temperature history of what

obtained from the finite element analysis and experiments. The finite element analysis results and the experiment agreed well. Fig. 10 shows the

results of maximum temperature distribution from the finite element analysis and the experiment of

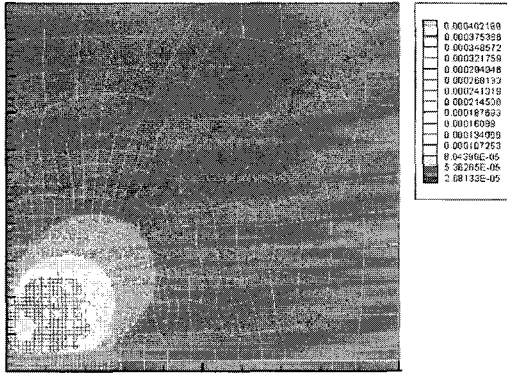

Fig. 7 Isolines of magnetic vector potential at initial state (wbm^{-1})

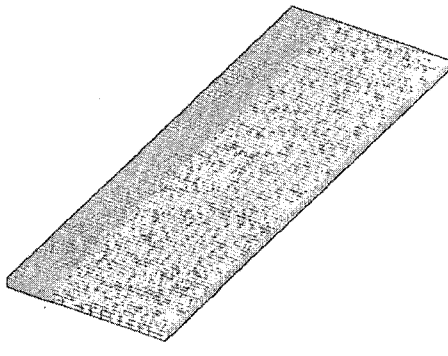

Fig. 8 Three dimensional half model of the steel plate for FEM

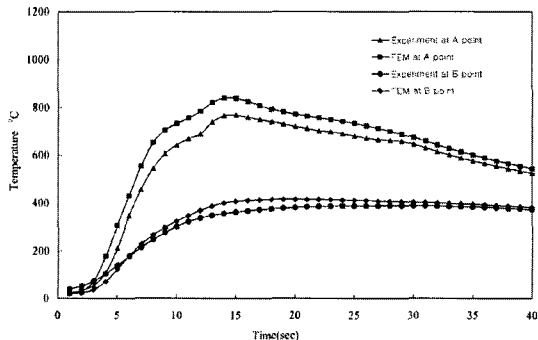

Fig. 9 Temperature history at bottom center of steel plate at 50 kHz

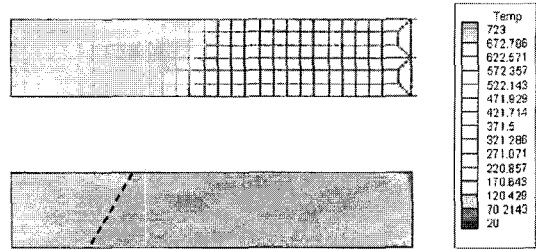

Fig. 10 Shapes of experimental and calculated heat affected zones

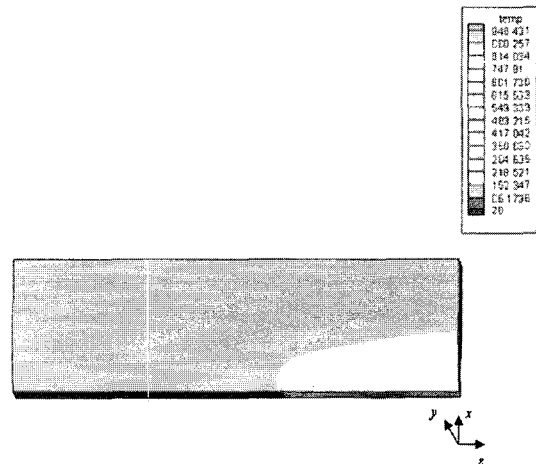

Fig. 11 Temperature distribution for induction heating (frequency=50 kHz, time=20 s)

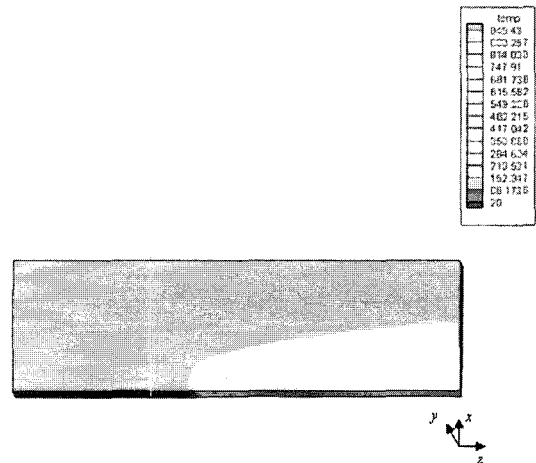

Fig. 12 Temperature distribution for induction heating (frequency=50 kHz, time=30 s)

the cross section. In the simulation, it was assumed that phase transformation temperature was 723°C. The heat affected zone inspected by experiment and calculated by finite element method agreed well. These results can be applied to stress analysis and also can be used to predict the angular distortion of steel plate (Son et al., 2000). Numerical temperature results for induction heating process are shown in Figs. 11 and 12, and the effect of velocity can be confirmed. Fig. 13 shows that maximum temperature with respect to frequency. As frequency increases to 30 kHz, the maximum temperature increases linearly. As frequency increases above 30 kHz, the increase slope of the maximum temperature decreases. If frequency increases, heat generation increases in equation (7), but magnetic vector potential is decreased. Therefore, total heat generation can be predicted by the coupled magneto-thermal analysis. Magnetic material properties and thermal material properties depend on temperature. When temperature increases, material properties also



Fig. 13 Maximum temperature according to frequency

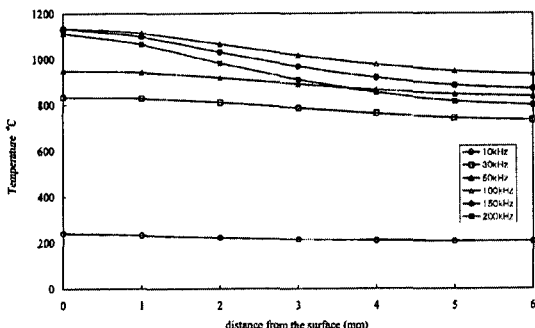

Fig. 14 Temperature distribution along the direction of depth according to frequency

change but not simultaneously for the whole workpiece. Therefore, the workpiece temperature is non-uniform, and a nonlinear coupled magnetic-thermal analysis is needed. So it seems that the nonlinear finite element analysis makes the result such as Fig. 13. The results of temperature distribution from the surface in the direction of depth according to frequency are shown in Fig. 14. It is found that the variation of the temperature at the high frequency is large as the distance from the surface increase. At the below of 50 kHz, heat generation increases as frequency increases. At the above of 50 kHz, heat generation becomes smaller as frequency increases because the skin effect becomes strong. The material properties of the workpiece depending on temperature affect the temperature results with regard to frequency.

4. Conclusions

For analyzing induction heating, a finite element program was developed based on information about electro-magnetic field and temperature distribution. For verifying the finite element program, finite element results were compared with experiment results. The finite element results agreed well with the experiment results. The finite element formulation using the movement of heating planes is effective for analyzing the induction heating process for a moving inductor coil. The skin effect was confirmed inside the steel plate in the electro-magnetic analysis. The shape of the heat affected zone from the experiment agreed well with the finite element results. At the high frequency, heat generation becomes smaller as frequency increases because the skin effect becomes strong. As temperature increases, material properties are changed but not simultaneously for the whole workpiece. Therefore, the workpiece temperature is non-uniform. The nonlinear coupled magneto-thermal finite element analysis is indispensable for analysis of induction heating process.

Acknowledgments

"This work was supported by the Korea Re-

search Foundation Grant funded by the Korean Government (MOEHRD)" (KRF-2005-202-D00041).

References

- Chaboudez, C., Clain, S., Glardon, R., Mari, D., Rappaz, J. and Swierkosz, M., 1997, "Numerical Modeling in Induction Heating for Axisymmetric Geometries," *IEEE Transactions on Magnetics*, Vol. 33, pp. 739~745.
- Enokizono, M. and Tanabe, H., 1995, "Numerical Analysis of High-Frequency Induction Heating Including Temperature Dependence of Material Characteristics," *IEEE Transactions on Magnetics*, Vol. 31, pp. 2438~2444.
- Garbulsky, G. D., Marino, P. and Pignotti, A., 1997, "Numerical Model of Induction Heating of Steel-Tube Ends," *IEEE Transactions on Magnetics*, Vol. 33, pp. 746~752.
- Gong, L., Hagel, R. and Unbehauen, R., 1995, "A New Approach to the Nonlinear Eddy Current Field Coupled to the Nonlinear Heat Transfer," *IEEE Transactions on Industry Applications*, Vol. 31, pp. 733~736.
- Huebner, K. H., Thornton, E. A. and Byrom, T. G., 1995, *The Finite Element Method for Engineers*, A Wiley-Interscience Publication.
- Masubuchi, K., 1980, *Analysis of Welded Structures*, Pergamon Press.
- Nerg, J. and Partanen, J., 2000, "Numerical Solution of 2D and 3D Induction Heating Problems with Non-Linear Material properties Taken into Account," *IEEE Transactions on Magnetics*, Vol. 36, pp. 3119~3121.
- Sadeghipour, K., Dopkin, J. A. and Li, K., 1996, "A Computer Aided Finite Element/Experimental Analysis of Induction Heating Process of Steel," *Computers in Industry*, Vol. 28, pp. 195~205.
- Son, K. J., Yang, Y.-S. and Beom, H. G., 2000, "Analysis of Angular Distortion in Weldments Using Laminated Plate Theory," *Science and Technology of Welding and Joining*, Vol. 5, pp. 245~249.
- Wu, H. W. and Chiu, C. P., 1988, "A Study on the Characteristics of Heat Transfer in an Engine Piston," *Journal of Mechanical Science and Technology*, Vol. 2, pp. 19~27.