

JPE 6-3-2

Power Quality Improvement of an Electric Arc Furnace Using a New Universal Compensating System

Ahmad Esfandiari^{†*}, Mostafa Parniani^{*}, Hossein Mokhtari^{*} and Ali Yazdian-Varjani^{**}

^{†*}Dept. of Electrical Eng., Sharif University of Technology, Tehran, Iran

^{**}Dept. of Electrical Eng., University of Tarbiat Modares, Tehran, Iran

ABSTRACT

This paper presents a new compensating system, consisting of series and shunt active filters, for mitigating voltage and current disturbances. The shunt filter is used to compensate for unbalanced and distorted load currents. The series filter comprises two inverters, used to suppress voltage disturbances and handle source currents independently. This configuration is devised to reduce the overall cost of active compensators by using low-frequency high-current switches for the latter inverter. The filters are controlled separately using a novel control strategy. Since voltages at the point of common coupling contain interharmonics, conventional methods cannot be used for extracting voltage references. Therefore, voltage references are obtained from generated sinusoidal waveforms by a phase-locked loop. Current references are detected based on rotating frame vector mapping. Simulation results are presented to verify the system.

Keywords: power quality, active filters, electric arc furnace, voltage flicker

1. Introduction

Application of nonlinear loads such as adjustable speed drives, electric arc furnaces (EAFs) and power conversion devices in power systems results in power quality problems such as harmonics, interharmonics and voltage fluctuations. These features force utilities and consumers to take countermeasures. Due to the variety of nonlinear loads and their problems, different compensation systems have been used. Passive filters are a conventional solution to mitigate harmonics. The limitation of passive filters for

compensating complex problems such as variable and noninteger harmonics has made active filters attractive. The series active filter is a controlled voltage source inverter. It is less common in the industry than shunt active filters, due to the drawbacks of series circuits. Also, it must handle high source currents, which increases its current rating considerably in comparison with shunt active filters. Shunt active filters are widely used in industrial applications^[1,2]. It has the advantage of carrying only the compensating currents. Also, it is possible to connect several filters in parallel to increase current capacity for high power applications.

Some loads such as electric arc furnaces have time varying currents that result in severe problems such as interharmonic and voltage fluctuations. Passive filters, series inductor^[3], static var compensators (SVCs)^[4-7], and

Manuscript received Nov16, 2005; revised April 25, 2006.

[†]Corresponding Author: shesf2000@yahoo.com

Tel: +98-21-6005317, Fax: +98-21-6023261

^{*}Dept. of Electrical Eng., Sharif University of Technology

^{**}Dept. of Electrical Eng., University of Tarbiat Modares

distribution static compensators (DSTATCOMs) ^[8] are compensating devices used to improve the EAF power quality. Passive filters cannot be used for compensating problems such as variable frequency harmonics and flicker. The series inductor causes a reduction of short circuit power and decreases productivity. While SVCs are widely used for EAF compensation, they have inherent delays, which limit their ability to suppress voltage flicker ^[9]. Besides, they inject a large amount of current harmonics, which need to be filtered. DSTATCOMs are inherently faster and produce fewer harmonics than SVCs, but compensate only for reactive power at the fundamental frequency.

In ^[10], nonlinear loads have been categorized into two types of harmonic sources, harmonic current source and harmonic voltage source. Shunt active filter can only compensate for harmonic current source loads ^[10]. An EAF has both harmonic current source and harmonic voltage source characteristics. Hence, a combined system of series and shunt active filters is the most suitable for meeting stringent power quality requirements ^[11].

Several investigations have been carried out on the combination of the two types of filters, usually referred to as universal power quality conditioner (UPQC). A specific UPQC has been implemented in ^[12] for eliminating voltage flicker and unbalance. In this work, DC voltage is regulated by the shunt active filter and current harmonics are alleviated by passive filters. In ^[13], a combination of series and shunt active filters as a universal power quality manager (UPQM) were employed to compensate for current harmonics, unbalance and fundamental component reaction, and to mitigate voltage harmonics, unbalance and flicker. Also, the performance of the UPQM depending on the sequence of installation of the two filters has been discussed. Both in ^[12] and ^[13], voltage flicker is simply modeled by a series, 5Hz, 4% voltage source. Also, other researchers have presented the UPQC approach to mitigate power quality problems ^[14], and to suppress voltage flicker and unbalance produced by AC arc furnace ^[15]. In ^[16], a discussion was carried out on the compensation capabilities of the UPQC.

The conventional combination of series and shunt active filters has two drawbacks, complicated control and high source current. The series filter generates compensating voltages which are small in comparison with the rated

system voltage. Therefore, large currents must pass through the inverter switches.

Detection of reference signals has a vital role in the effectiveness of active filters. Interharmonic components and nonstationary characteristic of disturbances make frequency-domain methods inefficient in reference signal detection. Time-domain methods, which are based on signal filtering and manipulation, obtain compensating signals in averaged or instantaneous forms. The reactive power of electric arc furnaces has widely varying values which requires a fast detection method. This can be achieved using the proposed method. The instantaneous reactive power theory based on a rotating reference frame is presented in ^[17-20] for three-phase four-wire systems and employed for reactive power compensation and neutral current elimination.

This paper presents a new compensating system for alleviating voltage and current disturbances. In order to overcome the shortcomings of the conventional series-shunt active filters, the power circuit topology of the system utilizes two inverters to generate voltage references and to handle source currents, separately. Thanks to this topology the series and shunt filters are controlled independently. Therefore, low-rating high-frequency switches are selected for the voltage generator inverter and high-rating low-frequency switches are used for the current handling inverter. An extended method is proposed for extracting the compensating signals to suppress the harmonics and to correct the power factor. The desired amplitude of the voltages is calculated from the measured values. Then, three voltage signals are generated by a PLL and are used to obtain voltage reference signals. Also, a new DC voltage control loop is presented which can be used in the presence of noninteger harmonics and flicker voltages at the PCC. It will be shown that the proposed scheme can improve power quality of widely varying loads in three-phase three-wire power systems with unbalanced voltages.

2. System Configuration

Fig. 1 shows the proposed compensating system with the parameters listed in Tables 1 and 2. It consists of series and shunt active filters. The two series active filters are

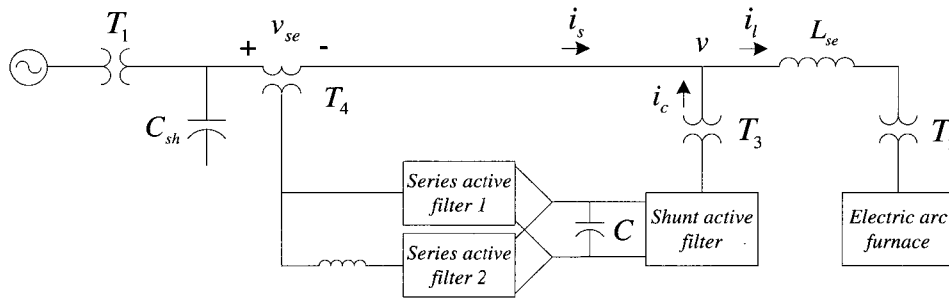

Fig. 1 System configuration

Table 1 Parameters of the simulated system

Parameter	Value
short circuit power, MVA	3500
shunt active filter inductance, mH	0.045
shunt active filter resistance, ohm	0.001
shunt active filter ac side capacitance, μ F	1.8
AC side inductance of series active filter 2, mH	4.6
AC side resistance of series active filter 2, ohm	0.08
series inductance, mH	10
DC bus capacitance, mF	15
DC bus voltage, kV	12
shunt capacitance, μ F	420

Table 2 Parameters of the transformers

Transformer	T ₁	T ₂	T ₃	T ₄
V ₁ (kV)/V ₂ (kV)	220/21	21/0.78	0.7/21	2/2
MVA	95	60	20	5.7
Resistance, pu	0.005	0.005	0.005	0.001
Inductance, pu	0.125	0.1	0.002	0.01

connected together at their AC terminals and connected to the network through a matching transformer T₄. The series filter 1 mitigates voltage disturbances from the PCC and series filter 2 handles source current flow through the secondary side of the matching transformer. The latter can handle high source currents via paralleled inverter branches and low frequency switches. The shunt active filter compensates for the load current disturbances and regulates common DC link voltage. The series inductor and shunt capacitor constitute the passive compensating device. These components limit the fast variations of load currents and mitigate voltage notching at the PCC. The

AC side impedance of the series active filter 2 is used to prevent short circuit of the AC sides of series filters 1 and 2. With regards to the power capability and switching speed of the semiconductor devices, IGBT is a suitable choice for the inverters.

3. Control Strategy

The control scheme of the system consists of detecting reference signals and controlling the inverter switching. Due to the special circuit topology of the compensator, control strategy is established independently for each part.

3.1 The current compensating signal detection

Instantaneous voltages and currents in the *abc* coordinates can be transformed on the orthogonal $\alpha\beta$ coordinates. As shown in Fig. 2, the $\alpha'qo$ coordinate set is formed by rotating the $\alpha\beta$ plane by θ_1 about the *o*-axis so that the α -axis aligns with the projection of the instantaneous voltage space vector on the $\alpha\beta$ plane. Therefore, the instantaneous current vector in the $\alpha'qo$ coordinate is obtained by applying the corresponding rotating transformation. Then, the *pqr* coordinates are obtained by rotating $\alpha'o$ plane by θ_2 about the *q*-axis so that the α' -axis aligns with the projection of instantaneous voltage space vector on the $\alpha'o$ plane. Therefore, the instantaneous voltage vector coincides with the *p*-axis. Also, the current vector on the *pqr* coordinates can be achieved by applying the corresponding rotating transformation. More details can be found in [21].

As shown in Fig. 1, at the PCC, one can write on the *abc* frame:

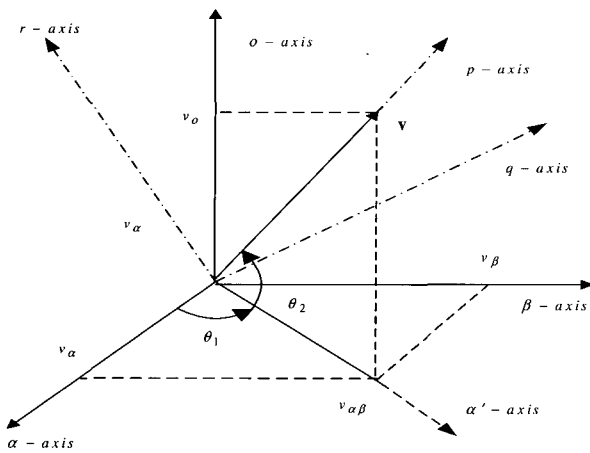

Fig. 2 Relation between $\alpha\beta$ and pqr reference frames

$$\begin{bmatrix} i_{sa} \\ i_{sb} \\ i_{sc} \end{bmatrix} + \begin{bmatrix} i_{ca} \\ i_{cb} \\ i_{cc} \end{bmatrix} = \begin{bmatrix} i_{la} \\ i_{lb} \\ i_{lc} \end{bmatrix} \quad (1)$$

By multiplying (1) in transformation matrix T ^[21], current relations are given in the pqr coordinates as:

$$\begin{bmatrix} i_{sp} \\ i_{sq} \\ i_{sr} \end{bmatrix} + \begin{bmatrix} i_{cp} \\ i_{cq} \\ i_{cr} \end{bmatrix} = \begin{bmatrix} i_{lp} \\ i_{lq} \\ i_{lr} \end{bmatrix} \quad (2)$$

Since the voltage vector is coincidental with the p -axis, fundamental frequency component of the phase voltages in the pqr frame is a DC value on the p -axis. The other components are superimposed on v_p as fluctuating values.

Instantaneous active current of load i_{lp} includes a DC value and an oscillatory component. The latter component determines oscillatory active power and should be compensated to achieve a constant active power.

$$i_{lp} = \bar{i}_{lp} + \tilde{i}_{lp} \quad (3)$$

where \bar{i}_{lp} and \tilde{i}_{lp} stand for DC and fluctuating components, respectively. \tilde{i}_{lp} can be extracted by passing i_{lp} through a low pass filter, and subtracting the output from i_{lp} . The cutoff frequency of the filter should be low enough to block all disturbance components. On the other hand, too low a bandwidth slows down the dynamic response of the device. An alternative method to remedy

this drawback is shown in Fig. 3. Three-phase currents are transformed from abc to dq values. The fundamental and low-frequency components are extracted utilizing low pass filters with the cut-off frequency of 85 Hz. Peak values of filtered positive signals $|\hat{i}_a|$, $|\hat{i}_b|$ and $|\hat{i}_c|$ are detected and used to define the amplitude of reference currents. This value is given as:

$$k_i = (i_{am} + i_{bm} + i_{cm}) / 3 \quad (4)$$

where $i_{im} = \max(|\hat{i}_i|)$, for $i=a,b$ and c .

Three current templates are obtained by multiplying k_i and the outputs of a sine-wave generator. Then, the resultant vector i_t is transformed to the pqr rotating frame. Thus, i_{tp} would be equivalent to \bar{i}_{lp} , and therefore, subtracting it from i_{lp} results in a load active current disturbance. Similarly, instantaneous reactive current i_{lq} has two components. Compensating the DC component results in power factor correction, whereas compensating its oscillatory component together with the oscillatory active current leads to harmonic elimination and load balancing. Therefore, an ideal compensation requires reference current space vectors in pqr coordinates be chosen as follows:

$$i_{cp}^* = \tilde{i}_{lp} \quad (5)$$

$$i_{cq}^* = i_{lq} \quad (6)$$

$$i_{cr}^* = i_{lr} = 0 \quad (7)$$

Finally, compensating signals in the abc frame are obtained as:

$$\begin{bmatrix} i_{ca}^* \\ i_{cb}^* \\ i_{cc}^* \end{bmatrix} = T^{-1} \begin{bmatrix} i_{cp}^* \\ i_{cq}^* \\ i_{cr}^* \end{bmatrix} \quad (8)$$

3.2 DC bus voltage control

Flow of instantaneous power through the inverter charges and discharges the inverter DC bus capacitor, causing changes in its voltage. Regulation of this voltage, which is essential for proper operation of the active filter, requires balancing active power exchange at the

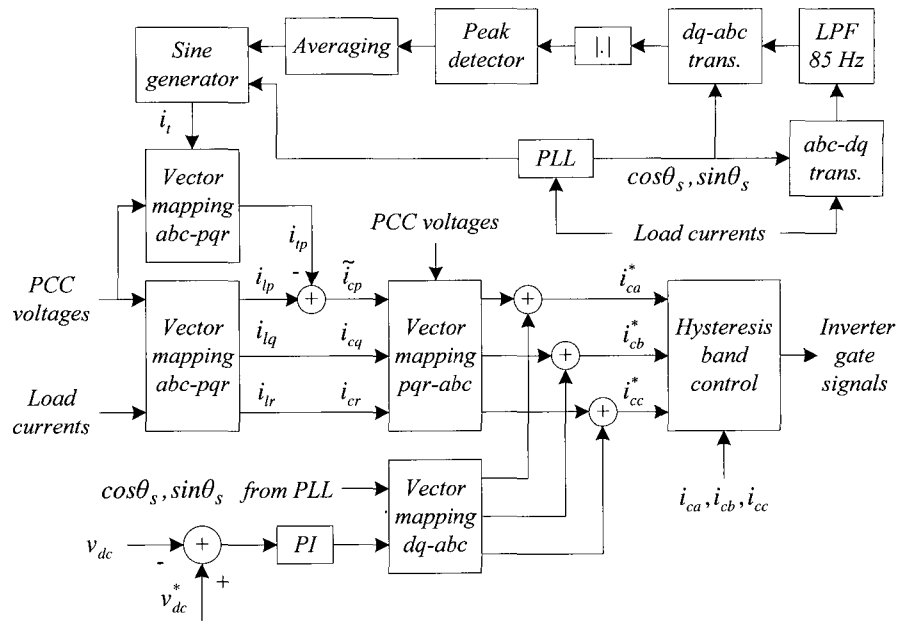

Fig. 3 Control block diagram of the shunt active filter

fundamental frequency. The shunt inverter is controlled to generate a fundamental frequency current signal in phase with the fundamental frequency voltage at the active filter terminals to regulate the DC bus voltage. When the active filter terminal voltages and load currents are polluted with noninteger low frequency harmonics, the current vector component which is in-phase with the voltage vector in the rotating reference frame cannot be directly used to establish the DC voltage control loop. This is because low pass filtering cannot be used as suggested in [22]. In order to overcome this problem, the difference in the measured DC voltage v_{dc} and its reference value v_{dc}^* is fed to a PI controller. The output of the PI controller is considered as a d -axis compensating current component in the synchronous reference frame dq . This signal is transformed to phase currents. Then, the output is used to modify the compensating signals [21]. An example of this control method is shown in Fig. 3.

3.3 The shunt active filter control

The hysteresis current controller determines the switching pattern of the inverter devices of the shunt active filter. In this method actual current is compared with the hysteresis band around the reference current. If the actual current tries to go beyond the upper hysteresis

band, the lower switch is turned on and the upper switch in turned off. If the actual current tries to go below the lower hysteresis band, the upper switch is turned on and the lower switch in turned off. The control block diagram of the shunt active filter is shown in Fig. 3.

3.4 The series active filter control

The main task of the series active filter is to mitigate the voltage disturbances at the PCC. Due to the existence of low frequency fluctuations on the PCC voltage signals, voltage flicker detection methods based on filtering, as suggested in [13] would not be efficient. In addition, the filter adversely affects the dynamic response of the series active filter [13]. The fundamental and low-frequency components of the voltage signals are extracted using a low pass filter with a cut-off frequency of 85 Hz. To extract these components, peak values of filtered positive signals $|\widehat{v}_a|$, $|\widehat{v}_b|$, $|\widehat{v}_c|$ are detected and used for defining amplitude of reference voltages. This value is given as:

$$\therefore k_v = (v_{am} + v_{bm} + v_{cm})/3 \quad (9)$$

Where $v_{im} = \max(|\widehat{v}_i|)$, for $i=a,b,c$. Three phase voltage templates are obtained by multiplying k_v at the outputs of a three phase sine-wave generator. The discrepancies

between these voltages and the PCC voltages are fed to a pulse-width modulation (PWM) controller to generate the gate signals for the first series active filter. The proposed scheme is depicted in Fig. 4.

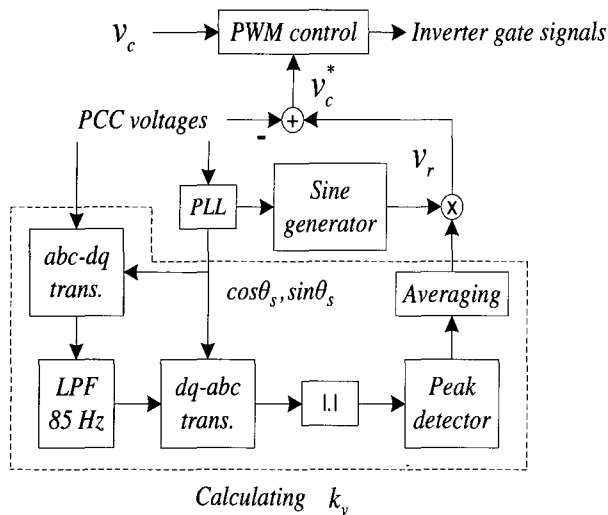

Fig. 4 Control block diagram of the series active filter 1

The second inverter is also controlled by hysteresis current control method. The reference signal of this part is a source current flowing at the secondary side of transformer T_4 . The hysteresis band is chosen in such a way as to keep the switching frequency low. Then the difference between the line and the second inverter currents flows through the first inverter.

4. Simulation Results

The system in Fig. 1 was simulated using Matlab/Simulink. The load is a 60 MVA electric arc furnace [3]. The three-phase EAF model used in the simulation studies is composed of two parts. The first part is a dynamic arc model in the form of a differential equation. The other part is related to the chaotic characteristics of the arc voltage. More details about the EAF model can be found in [23]. The PI controller parameters in the control loop of the DC bus voltage are chosen as $k_p = 0.93$, $k_i = 0.0996$ [24].

4.1 Power quality problems

First, in order to indicate the power quality impact of the simulated EAF, the system was studied without the mitigating system. In addition to the voltage and current harmonics, the EAF generates voltage flicker, imbalance, and notching. Similar problems were observed in the load currents. Fig. 5 shows voltage notching, unbalance and flicker.

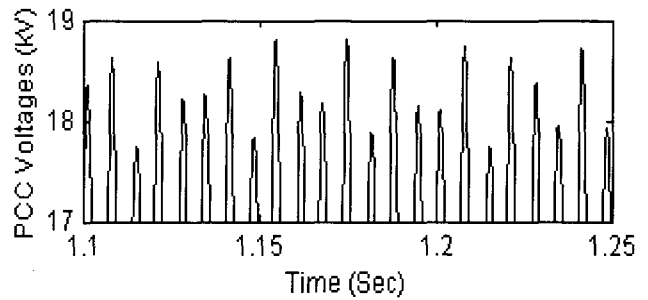

Fig. 5 Three phase PCC voltages after passive compensation

Load currents are depicted in Fig. 6. Fast fourier transform (FFT) of the load current has a continuous distribution of harmonic content. The harmonic values of some of the important components are mentioned in Table 3.

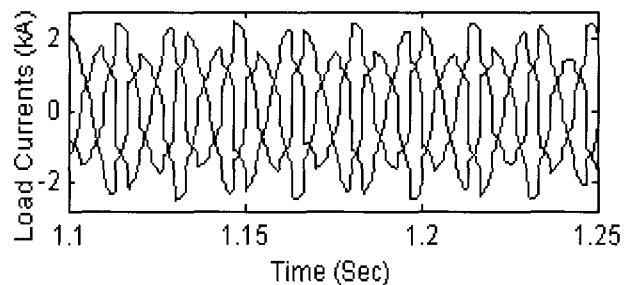

Fig. 6 Three phase load currents

4.2 Compensation results

Sole insertion of a series inductor may cause reduction of short circuit power at the PCC and decrease productivity of EAF [3]. In contrast, a suitably sized series inductor and a shunt capacitor can be used together with the active filter to mitigate flicker and improve power quality. The passive components limit rapid variations of the EAF currents and eliminate the voltage notching as shown in Fig. 7.

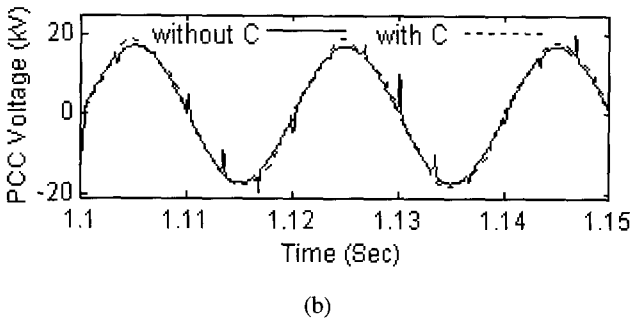
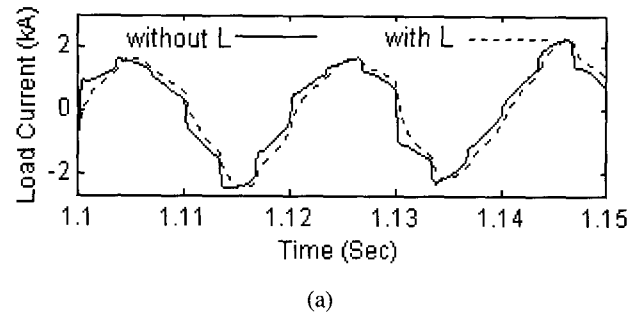

Fig. 7 Passive filters effect
(a) Load current (b) Voltage notching

The mitigating system efficiently reduces source current harmonics in the 0-0.9 kHz frequency range, as depicted in Table 3. Comparison of the harmonic content in the load and source currents indicates that in addition to the integer harmonics, noninteger harmonics are considerably suppressed. The total harmonic distortion (THD) of the source current for a phase varies between 11.6% and 24.3% before compensation. This value is reduced to lower than 3.8% after compensation and meets the requirements of the IEEE-519 standards [25]. Also, comparison of Figs. 6 and 8 indicates that current imbalance is considerably reduced in this compensating system.

Table 3 Harmonic content of source current

H	10	110	190	250	290	310	350
A1	13.8	13.4	4.3	10.7	3.4	3.9	8.1
A2	2.8	3.1	0.24	0.6	0.3	0.12	0.68
H	410	490	550	590	610	650	850
A1	3.2	1.8	4.7	1.6	1.8	3.8	2.5
A2	0.2	0.11	0.21	0.0	0.0	0.3	0.12
H: Harmonic no.							
A1: Harmonic amplitude before compensation							
A2: Harmonic amplitude after compensation							

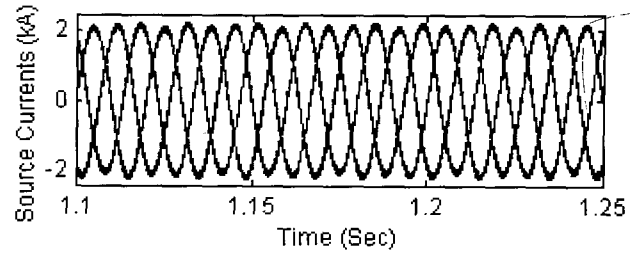

Fig. 8 Source currents

The shunt active filter current for phase a is shown in Fig. 9. Series inverter 2 generates voltage compensating signals as depicted in Fig. 10. Series inverter 2, as shown in Fig. 12, mainly handles the line current flowing in the secondary side of T_4 . Comparison of these currents indicates that %5.7 and %94.3 of source current are handled by series inverters 1 and 2, respectively. Average switching frequency of series inverter 1 is about 12 kHz and that of series inverter 2 is 2.2 kHz. Load and source instantaneous reactive powers in Figs. 13 and 14 indicate the capability of the mitigating system in compensating for highly varying EAF reactive power.

Voltages at the PCC before and after compensation are shown in Figs. 5 and 15, respectively. Comparison of these figures show the voltage imbalance is suppressed effectively.

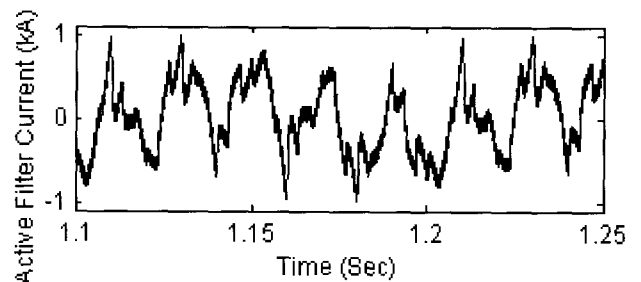

Fig. 9 Shunt active filter current, phase-a.

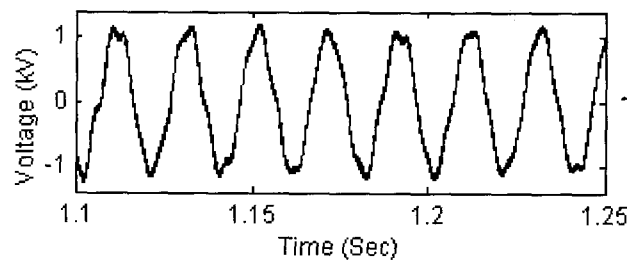

Fig. 10 Series active filter 1 generated voltage, phase-a.

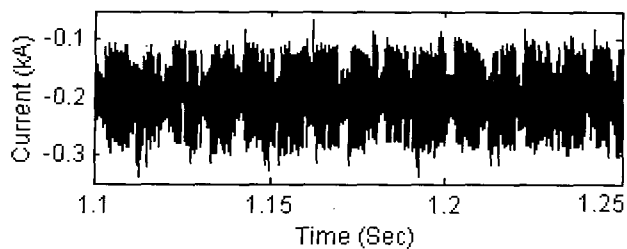

Fig. 11 Series active filter 1 current, phase-a.

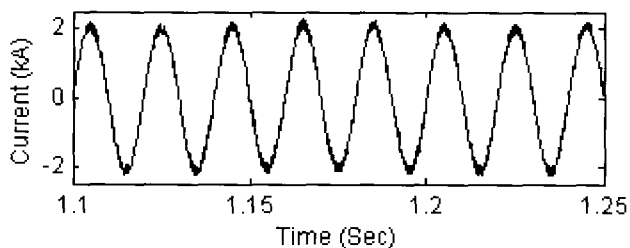

Fig. 12 Series active filter 2 current, phase-a.

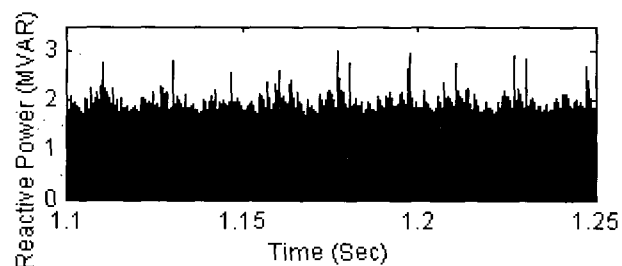

Fig. 13 Source instantaneous reactive power

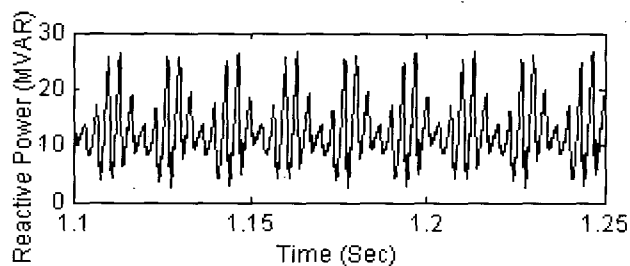

Fig. 14 Load instantaneous reactive power

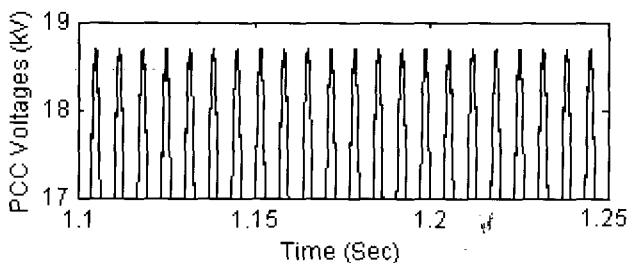

Fig. 15 Three phase PCC voltages after compensation

Spectrum analysis of the PCC voltages indicates that the values of 10 Hz and 110 Hz in the voltage signal before compensation are 0.14% and 1.13%. They are reduced to 0.01% and 0.009%, respectively, after compensation.

The other part of the control strategy is the DC link voltage regulation. Based on the capacitor voltage shown in Fig. 16, one can see that the voltage control loop offers efficient performance in under unbalanced and flicker PCC voltages.

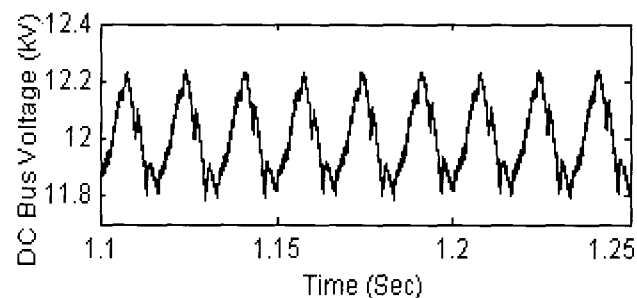

Fig. 16 DC bus capacitor voltage

5. Conclusions

In this paper, a new combination of series and shunt active filters is proposed for an improved power quality supply system for an electric arc furnace. The compensator mitigates the PCC voltage and load current disturbances and compensates for reactive power, harmonics, interharmonics, and imbalance. The advantages of the proposed configuration are effective handling of high source current by the series active filter and decoupling the controls of the series and shunt active filters. One of the series inverters operates at high-current low-frequency, while the other one is a low-current high-frequency inverter. Thus, proper switches can be selected for the inverters with regards to switching frequency and current rating. A new method for extracting the voltage reference signals has also been proposed, which performs efficiently in the presence of PCC voltages polluted with low frequency interharmonics. The detection methods for voltage and current compensating signals provide efficient performance for the series and shunt active filters.

References

- [1] W. M. Grady, M. J. Samotyj, A. H. Noyola, "Survey of active power line conditioning methodologies," *IEEE Trans. Power Deliv.*, Vol. 5, No. 3, pp. 1536~1542, July 1990.
- [2] H. Akagi, "New trends in active filters for power conditioning," *IEEE Trans. Ind. Appl.*, Vol. 32, No. 6, pp. 1312~1322, Nov./Dec. 1996.
- [3] G. C. Montanari, M. Loggini, L. Pitti, E. Tironi, and D. Zaninelli, "The effects of series inductors for flicker reduction in electric power systems supplying arc furnaces," in *Proc. IEEE IAS Annual Meeting*, pp. 1496~1503, Canada, 1993.
- [4] L. Gyugi and A. A. Otto, "Static shunt compensation for voltage flicker reduction and power factor correction," in *Proc. American Power Conf.*, pp. 1271~1286, USA, 1976.
- [5] I. Hosono, M. Yano, M. Takeda, S. Yuya, and S. Sueda, "Suppression and measurement of arc furnace flicker with a large static var compensator," *IEEE Trans. Power App. and Syst.*, Vol. PAS-98, No. 6, pp. 2276~2282, Nov./Dec. 1979.
- [6] A. Wolf and M. Thamodharan, "Reactive power reduction in three-phase electric arc furnace," *IEEE Trans. Ind. Electron.*, Vol. 47, No. 4, pp. 729~733, Aug. 2000.
- [7] C. Surapong, C. Y. Yu, D. Thukaram, T. Nipon, and K. Damrong, "Minimization of the effects of harmonics and voltage dip caused by electric arc furnace," in *Proc. IEEE PES Winter Meeting*, pp. 2568~2576, Singapore, 2000.
- [8] J. R. Clouston and J. H. Gurney, "Field demonstration of a distribution static compensator used to mitigate voltage flicker," in *Proc. IEEE PES Winter Meeting*, pp. 1138~1141, USA, 1999.
- [9] L. Gyugyi, "Dynamic compensation of AC transmission lines by solid-state synchronous voltage sources," *IEEE Trans. Power Deliv.*, Vol. 9, No. 2, pp. 904~911, Apr. 1994.
- [10] F. Z. Peng, "Application issues of active power filters," *Ind. Appl. Magazine, IEEE*, Vol. 4, No. 5, pp. 21~30, Sep./Oct. 1998.
- [11] B. Singh, K. Al-Haddad, A. Chandra, "A review of active filters for power quality improvement," *IEEE Trans. Ind. Electron.*, Vol. 46, No. 5, pp. 960~971, Oct. 1999.
- [12] H. Fujita and H. Akagi, "The unified power quality conditioner: the integration of series and shunt active filters," *IEEE Trans. Power Electron.*, Vol. 13, No. 2, pp. 315~322, Mar. 1998.
- [13] A. Elmitwally, S. Abdelkader, M. Elkateb, "Universal power quality manager with a new control scheme," *IEE Proc. Gen. Trans. Dist.*, Vol. 147, No.3, pp. 183~189, May 2000.
- [14] G. Jianjun, X. Dianguo, L. Hankui, and G. Maozhong, "Unified power quality conditioner (UPQC): the principle, control and application," in *Proc. Power Conversion Conf.*, pp. 80~85, Japan, 2002.
- [15] A. Elnady, W. Elkhattam, and M. A. Salama, "Mitigation of AC arc furnace voltage flicker using the unified power quality conditioner," in *Proc. IEEE PES winter Meeting*, pp. 735~739, USA, 2002.
- [16] A. Elnady and M. A. Salama, "New functionalities of the unified power quality conditioner," in *Proc. IEEE/PES Trans. and Dist Conf. and Expos.*, pp. 415~420, USA, 2001.
- [17] H. Kim, H. Akagi, "The instantaneous power theory based on mapping matrices in three-phase four-wire systems," in *Proc. Power Conversion Conf.*, pp. 361~366, Japan, 1997.
- [18] H. Kim, H. Akagi, "The instantaneous power theory on the rotating p-q-r reference frames," *IEEE Intern. Conf. on PEDS*, pp. 422~427, Hong Kong, 1999.
- [19] F. Z. Peng, J. Lai, "Generalized instantaneous reactive power theory for three-phase power systems," *IEEE Trans Instrument. and Meas.*, Vol. 45, No. 1, pp. 293~297, Feb. 1996.
- [20] H. Akagi, S. Ogasawara, and H. Kim, "The theory of instantaneous power in there-phase four-wire systems: a comprehensive approach," *IEEE IAS Annual Meeting*, pp. 431~439, USA, 1999.
- [21] A. Esfandiari, M. Parniani, and H. Mokhtari, "A new control strategy of shunt active filters for power quality improvement of highly and randomly varying loads," in *Proc. ISIE2004*, pp. 1297~1302, France, 2004.
- [22] A. Esfandiari, M. Parniani, and H. Mokhtari, "Shunt active filter control based on instantaneous power theory on a rotating reference frame in 3-phase systems," in *Proc. PEMC2004*, Latvia, 2004.
- [23] O. Ozgun, A. Abur, "Flicker study using a novel arc furnace model," *IEEE Trans. Power Deliv.*, Vol. 17, No. 4, July 2002, pp. 1158~1163.
- [24] N. Mendalek and K. Al-Haddad, "Modeling and nonlinear control of shunt active power filter in the synchronous reference frame," in *Proc. HQP*, pp. 30~35, USA, 2000.
- [25] *IEEE Standard 519-1992: Recommended Practices and Requirements for Harmonic Control in Electrical Power Systems*, IEEE, 1993.



and power quality.

Ahmad Esfandiari was born in Sarband, Iran in 1973. He received his B.Sc. and M.Sc. degrees in Electrical Engineering from Sharif University of Technology, Tehran, Iran, in 1996 and 1998, respectively. His interests include applications of power electronics,

strategic planning for Information and Communication Technology (ICT) development in the Iran Telecom Research Centre (ITRC) as a senior consultant. His other major research is in the area of digital signal processing applicable for harmonics (power quality) and power electronic based drive systems. Current academic interests include a variety of research issues associated with "information and communication technology" including internet enabled services, ad hoc networking, network security and control.



Mostafa Parniani (Senior Member, IEEE) received his B.Sc. degree from Amirkabir University of Technology in 1987, and his M.Sc. degree from Sharif University of Technology (SUT) in 1989, both in Electrical Power Engineering. He worked for Ghods-Niroo Consulting Engineers Co. and for Electric Power Research Center (EPRC) in Tehran during 1988-90. He obtained the Ph.D. degree in Electrical Engineering from the University of Toronto, Canada, in 1995. Then, he joined the Department of Electrical Engineering, SUT, as an assistant professor. He is currently a visiting scholar at Rensselaer Polytechnic Institute, USA. His research interests include power system dynamics and control, and Flexible AC transmission Systems (FACTS).



Hossein Mokhtari was born in Tehran, Iran. He received this B.Sc. degree in Electrical Engineering from Tehran University, Tehran, Iran in 1989. He worked as an engineering consultant engineer for Electric Power Research Center (EPRC) in Tehran in dispatching projects. In 1994, He received his M.A.Sc. degree from the University of New Brunswick, Fredericton, N.B., Canada. He obtained his Ph.D. degree in Electrical Engineering from the University of Toronto in 1998. He is currently an associate professor in the Electrical Engineering Department of Sharif University of Technology. His research interests includes power quality and power electronics.



Ali Yazdian. Varjani (Member, IEEE) received his B.Sc degree from the Sharif University of Technology in 1989 and M.Eng and PhD in Electrical Engineering from the University of Wollongong , Australia, in 1995 and 1999 respectively. Prior to joining the University of Tarbiat Modares Dr. Ali was employed (1988 to 1990) as an Electric and Computer Engineer by Electric Power Research Centre, Tehran, Iran. From 1999-2000 he was the Technical Manager of Iran University Network project in the Iranian Research Organization for Science and Technology (IROST). From 2001-2004, Dr. Ali was involved in