

Frequency Response Analysis of Cylindrical Shells Conveying Fluid Using Finite Element Method

Young-Soo Seo, Weui-Bong Jeong*, Wan-Suk Yoo

*Department of Mechanical Engineering, Pusan National University,
Jangjeon-dong, Kumjung-ku, Pusan 609-735, Korea*

Ho-Kyeong Jeong

*Structure & Materials Department KSLV Technology Division,
45 Eoeun-Dong, Yuseong-Gu, Daejeon 305-333, Korea*

A finite element vibration analysis of thin-walled cylindrical shells conveying fluid with uniform velocity is presented. The dynamic behavior of thin-walled shell is based on the Sanders' theory and the fluid in cylindrical shell is considered as inviscid and incompressible so that it satisfies the Laplace's equation. A beam-like shell element is used to reduce the number of degrees-of-freedom by restricting to the circumferential modes of cylindrical shell. An estimation of frequency response function of the pipe considering of the coupled effects of the internal fluid is presented. A dynamic coupling condition of the interface between the fluid and the structure is used. The effective thickness of fluid according to circumferential modes is also discussed. The influence of fluid velocity on the frequency response function is illustrated and discussed. The results by this method are compared with published results and those by commercial tools.

Key Words : Fluid-Structure Interaction, Frequency Response Analysis,
Beam-like Shell Element, Effective Thickness

1. Introduction

The dynamic behavior of a cylindrical shell conveying fluid is a practical interest in the field of the power plants or oil pipelines. The structural characteristics of cylindrical shells can be analyzed by the commercial software such as Nastran. The commercial software for structural analysis deals with internal fluid as added mass. However, the internal fluid with velocity has effects on not only mass but also damping and stiffness of the shell structure. The added mass of the internal fluid changes according to the

circumferential mode. The pipe system with fluid flows has studied for a long time. These studies dealt with pipes as Euler-Bernoulli beam, Timoshenko beam and thin cylindrical shell. The pipe which behaves like a beam was surveyed by Paidoussis and Issid (1974). They discussed the dynamics and stability of pipes conveying fluid with various boundary conditions and a steady and a turbulent flow. Ginsberg (1973) carried out the stability analysis, based on the Floquet theory, of the pipe with a pulsating flow. Paidoussis and Sundararajan (1975) developed numerical methods to check whether a point lies in the stable or the unstable region by calculating the determinant of a large matrix for every point in the parametric space.

The dynamics of thin cylindrical shell is studied extensively by Donnell (1993), Love (1952) and Sanders (1963). These shell theories are used to solve the behavior of pipes conveying fluid.

* Corresponding Author,

E-mail : wbjeng@pusan.ac.kr

TEL : +82-51-510-2337; FAX : +82-51-517-3805

Department of Mechanical Engineering, Pusan National University, Jangjeon-dong, Kumjung-ku, Pusan 609-735, Korea. (Manuscript Received July 28, 2004; Revised November 24, 2004)

Mazuch et al.(1996) studied thin walled shells in contact with inviscid, incompressible fluid by finite element method and experiment. The natural frequencies and the mode shapes for the free vibrations of shell were computed and measured. Jain (1974) investigated the dynamics of orthotropic cylindrical shell. He used the Love's shell theory and potential flow theory. A similar case for the compressible fluid was studied by Chen et al.(1997). Selmane and Lakis (1997) presented the vibration of an open anisotropic shell with flowing fluid. They investigated the influence of flowing fluid on the vibration of the shell. Zhang et al.(2001) presented the dynamics of the thin shell conveying fluid by applying Sanders' thin shell theory. He used the finite element method to analyze the shell and the fluid. Lee et al.(1999) developed the a nonlinear finite element program using 3-D degenerated shell element and the first order shear deformation theory to consider the large deformation of the clamped laminated cylindrical shell. Ryu et al.(2004) investigated the stress on orthotropic composite cylindrical shells using the equation of Donnell's theory and presented the result as the stress concentration factor. However, most of previous works were interested in only the natural frequencies or the stability analysis. The frequency response characteristics of forced vibration of the cylindrical shell conveying fluid have not been discussed.

In this paper, a cylindrical shell conveying fluids is modeled by finite element method based on Zhang et al.(2001) in order to develop the frequency response analysis of the forced vibration. The dynamic behavior of cylindrical shell is assumed to satisfy the Sanders' thin shell theory. The fluid is assumed to satisfy the Laplace's equation. A beam-like shell element is used to reduce the number of nodes because shell element needs lots of nodes. A dynamic pressure of the fluid is obtained from the compatibility condition that the radial component of the internal fluid and the shell structure has the same velocity. This method does not need to generate meshes for the internal fluid because the pressure in the fluid is solved analytically. The effective mass of the fluid is obtained according to the circumferential

mode. The velocity of fluid has effects on the damping and the stiffness of the pipe. The frequency response function of the pipe with taking into consideration of the coupled effects of the fluid is presented. Some numerical results by this method are compared with those by Nastran (2001), commercial structural analysis software, and experimental results of previous work (Mazuch et al., 1996).

2. Finite Element Formulation

2.1 Dynamics of cylindrical shell

A cylindrical shell conveying internal fluid is modeled as shown in Fig. 1. The Sanders' thin shell theory is used to derive the equation of motion of the cylindrical shell. That is, the shell thickness is infinitesimal in comparison with the radius of curvature (i.e., $R/h > 10$), the displacement is small, and the shell wall thickness remains constant. The finite element method is used to analyze the dynamics of the cylindrical shell containing fluid. The kinetic energy, potential energy and virtual work which are acting on element can be expressed as follows :

$$T_e = \frac{1}{2} \int_{A_s} \rho_s h \{ \dot{u} \}^T \{ \dot{u} \} dA_s \quad (1)$$

$$U_e = \frac{1}{2} \int_{A_s} \{ \varepsilon \}^T [D] \{ \varepsilon \} dA_s \quad (2)$$

$$\delta W = \int_{A_s} \{ \delta u \}^T (\{ p_s \} + \{ q_s \}) dA_s \quad (3)$$

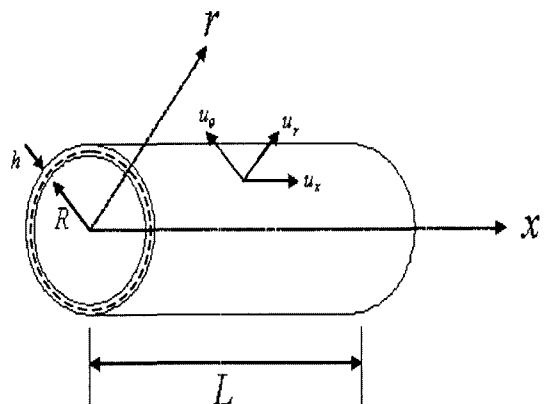

Fig. 1 A model of cylindrical shell conveying internal fluid

where p_s is pressure of the fluid acting on the surface of the cylindrical shell and q_s is external force acting to cylindrical shell. The relation of strain vector $\{\varepsilon\}$ and displacement vector $\{\bar{u}\}$ is given by

$$\{\varepsilon\}=[B]\{\bar{u}\} \tag{4}$$

And, the relation of stress vector $\{\sigma\}$ and strain vector $\{\varepsilon\}$ can be expressed by

$$\{\sigma\}=[D]\{\varepsilon\} \tag{5}$$

where

$$\{\sigma\}=\{N_{xx}, N_{\theta\theta}, N_{x\theta}, M_{xx}, M_{\theta\theta}, M_{x\theta}\}^T=[D]\{\varepsilon\}$$

$$\{\varepsilon\}=\left\{\begin{array}{l} \frac{\partial u_x}{\partial x} \\ \frac{1}{R}\left(\frac{\partial u_\theta}{\partial \theta}+u_r\right) \\ \frac{\partial u_\theta}{\partial x}+\frac{1}{R}\frac{\partial u_x}{\partial \theta} \\ -\frac{\partial^2 u_r}{\partial^2 \theta} \\ -\frac{1}{R^2}\left(\frac{\partial^2 u_r}{\partial^2 \theta}-\frac{\partial u_\theta}{\partial \theta}\right) \\ -\frac{2}{R}\frac{\partial^2 u_r}{\partial x \partial \theta}+\frac{3}{2R}\frac{\partial u_\theta}{\partial x}-\frac{1}{2R^2}\frac{\partial u_x}{\partial \theta} \end{array}\right\}$$

$$[D]=\left[\begin{array}{cccccc} \frac{Eh}{1-\nu^2} & \frac{\nu Eh}{1-\nu^2} & 0 & 0 & 0 & 0 \\ \frac{\nu Eh}{1-\nu^2} & \frac{Eh}{1-\nu^2} & 0 & 0 & 0 & 0 \\ 0 & 0 & \frac{Eh}{2(1+\nu)} & 0 & 0 & 0 \\ 0 & 0 & 0 & \frac{Eh^3}{12(1-\nu^2)} & \frac{\nu Eh^3}{12(1-\nu^2)} & 0 \\ 0 & 0 & 0 & \frac{\nu Eh^3}{12(1-\nu^2)} & \frac{Eh^3}{12(1-\nu^2)} & 0 \\ 0 & 0 & 0 & 0 & 0 & \frac{Eh^3}{24(1+\nu)} \end{array}\right]$$

The shell element type could be used to formulate the cylindrical shell. But it needs lots of element generation which cause the problems of memories and computations. Let us assume the displacement of a cylindrical shell by the following Fourier's cosine expansion :

$$\bar{u}=\{u_x \cos n\theta, u_\theta \sin n\theta, u_r \cos n\theta\}^T \tag{6}$$

where u_x , u_θ and u_r are the displacements of

shell in axial, tangential and radial direction. The circumferential modes of axial and radial displacements are assumed as $\cos n\theta$ ($n=0, 1, 2, \dots$), and that of tangential mode is assumed as $\sin n\theta$ ($n=0, 1, 2, \dots$). This assumption is reasonable for circular cross-section (Petyt, 1990). Figure 2 shows the circumferential mode shapes according to the circumferential mode number (n). This assumption makes it possible not to generate meshes in circumferential direction, which gives the reduction of degree-of-freedom in finite element formulation. This type of element is called beam-like shell element in this paper. The beam-like shell element generate meshes the same as beam element. For finite element formulation, the displacements in elements should be expressed by shape function and nodal displacements as follows :

$$u_x=[N_1(x) \ N_2(x)]\begin{Bmatrix} u_{xi} \\ u_{xi} \end{Bmatrix}=[N_{sx}]\{u_x\}_e \tag{7}$$

$$u_\theta=[N_3(x) \ N_4(x)]\begin{Bmatrix} u_{\theta i} \\ u_{\theta i} \end{Bmatrix}=[N_{s\theta}]\{u_\theta\}_e \tag{8}$$

$$u_r=[N_5(x) \ N_6(x) \ N_7(x) \ N_8(x)]\begin{Bmatrix} u_{ri} \\ \phi_i \\ u_{rj} \\ \phi_j \end{Bmatrix}=[N_{sr}]\{u_r\}_e \tag{9}$$

The radial displacement of cylindrical shell can be assumed to behave like a lateral displacement of a beam. Thus, the shape function in Eq. (9) is the same as that of lateral vibration of a beam. The $\phi=\partial u_r/\partial x$ denotes the slope of u_r . So, the displacements in elements can be simply written as follows :

$$\{u\}=\{u_x \ u_\theta \ u_r\}^T=[N_s]\{\bar{u}\} \tag{10}$$

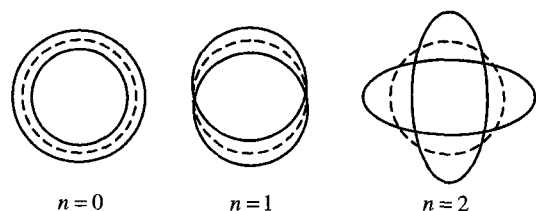

Fig. 2 Circumferential mode shapes according to the circumferential mode number (n)

where

$$\{\bar{u}\} = \{\bar{u}_{xi} \bar{u}_{\theta i} \bar{u}_{ri} \phi_i \bar{u}_{xj} \bar{u}_{\theta j} \bar{u}_{rj} \phi_j\}^T \quad (11)$$

Here, $[N_s]$ is a shape function matrix and $\{\bar{u}\}$ is a nodal displacement vector. Any shape function, $N_i (i=1, \dots, 8)$, can be defined by user. Linear functions of shape functions are used in this paper.

Substituting Eqs. (4), (5) and (10) into Eqs. (1)–(3) gives the mass, the stiffness matrix and the force vector of the cylindrical structure as follows :

$$\begin{aligned} [m]_s &= \int_{A_s} \rho_s h [N_s]^T [N_s] dA_s \\ &= \rho_s h R \int_0^{2\pi} \int_0^{l_e} [N_s]^T [N_s] dx d\theta \end{aligned} \quad (12)$$

$$\begin{aligned} [k]_s &= \int_{A_s} [B]^T [D] [B] dA_s \\ &= R \int_0^{2\pi} \int_0^{l_e} [B]^T [D] [B] dx d\theta \end{aligned} \quad (13)$$

$$\{f\}_s = \int_{A_s} [N_{sr}]^T p_d dA_s + \int_{A_s} [N_s]^T q_s dA_s \quad (14)$$

where ρ_s is the density of shell and R is a radius of cross-section and h is a wall thickness. The first term in Eq. (14) is the coupling effect of the fluid. The pressure p_d of the fluid at the interface acts normally on the structure of cylindrical shell. The second term of Eq. (14) is equivalent force due to external distributed force q_s .

2.2 Dynamics of internal fluid

It is assumed that the fluid in a cylindrical shell is incompressible, irrotational and inviscid so that the behavior of fluid satisfies the Laplace's equation. The Laplace's equation in cylindrical polar coordinate is as follows :

$$\nabla^2 \Phi = \frac{\partial^2 \Phi}{\partial r^2} + \frac{1}{r^2} \frac{\partial^2 \Phi}{\partial \theta^2} + \frac{\partial^2 \Phi}{\partial x^2} + \frac{1}{r} \frac{\partial \Phi}{\partial r} = 0 \quad (15)$$

where Φ is the velocity potential of the fluid. The velocity of fluid, \vec{v} , can be obtained from the relation $\vec{v} = \nabla \Phi$. A method of separation of variable is used to solve Eq. (15). The potential function is assumed as follows :

$$\Phi(r, \theta, x, t) = \Psi(r) \Re(x, \theta, t) \quad (16)$$

The general solution $\Psi(r)$ can be easily obtained by substituting Eq. (16) into Eq. (15) as follows :

$$\Psi(r) = C_1 J_n(\lambda r) + C_2 Y_n(\lambda r) \quad (17)$$

where C_1 and C_2 are constant. Here, $J_n(\lambda r)$ and $Y_n(\lambda r)$ denote the Bessel function of the first and second kind of order n . In order to have finite value of pressure in the center of the cross-section ($r=0$), C_2 must be zero.

To be fully coupled between the shell and fluid, the radial velocities of the shell and fluid must be the same at the interface. Thus, the following compatibility condition can be obtained.

$$v_r = \frac{\partial \Phi}{\partial r} = \frac{\partial u_r}{\partial t} + U \frac{\partial u_r}{\partial x} \Big|_{r=R} \quad (18)$$

Here, U is the steady velocity of the fluid. Substituting Eq. (17) and Eq. (18) into Eq. (16) yields

$$\Phi(r, \theta, x, t) = \frac{J_n(\lambda r)}{\partial J_n(\lambda R) / \partial r} \left(\frac{\partial u_r}{\partial t} + U \frac{\partial u_r}{\partial x} \right)_{r=R} \quad (19)$$

This characteristic values, λ , can be obtained from the characteristic equation (Zhang et al., 2001). The velocity of internal fluid can be obtained from velocity potential function as follows :

$$\vec{v} = \begin{Bmatrix} v_x \\ v_\theta \\ v_r \end{Bmatrix} + \begin{Bmatrix} U \\ 0 \\ 0 \end{Bmatrix} = \begin{Bmatrix} \frac{\partial \Phi}{\partial x} \\ \frac{1}{r} \frac{\partial \Phi}{\partial \theta} \\ \frac{\partial \Phi}{\partial r} \end{Bmatrix} + \begin{Bmatrix} U \\ 0 \\ 0 \end{Bmatrix} \quad (20)$$

The dynamic pressure of the fluid can also be obtained from velocity potential :

$$p_d = -\rho_f \left(\dot{\Phi} + U \frac{\partial \Phi}{\partial x} \right) \quad (21)$$

where ρ_f is the density of fluid.

2.3 Coupled equation of motion

The dynamic pressure of fluid acting on the surface of cylindrical shell can be obtained by substituting Eq. (9) and Eq. (19) into Eq. (21), which yields

$$p_d = -\rho_f([N_{sr}]\{\ddot{\bar{u}}\} + 2U[N'_{sr}]\{\dot{\bar{u}}\} + U^2[N''_{sr}]\{\bar{u}\}) \operatorname{Re}\left(\frac{J_n(\lambda R)}{\partial J_n(\lambda R)/\partial r}\right) \quad \{f\}_s = \{\bar{f}\}e^{j\omega t} \quad (22)$$

Substituting Eq. (22) into Eq. (14) and taking their real part, the equation of motion of a cylindrical shell with taking into consideration of the coupled effects of internal fluid yields

$$([m]_s + [m]_f)\{\ddot{\bar{u}}\} + [c]_f\{\dot{\bar{u}}\} + ([k]_s + [k]_f)\{\bar{u}\} = \{f\}_s \quad (23)$$

where,

$$[m]_f = \int_{A_f} \rho_f [N_{sr}]^T [N_{sr}] h_f dA_f \quad (24)$$

$$[c]_f = 2U \int_{A_f} [N_{sr}]^T \frac{\partial [N_{sr}]}{\partial x} h_f dA_f \quad (25)$$

$$[k]_f = -U^2 \int_{A_f} \frac{\partial [N_{sr}]^T}{\partial x} \frac{\partial [N_{sr}]}{\partial x} h_f dA_f \quad (26)$$

where $[m]_s$, $[k]_s$ is given by Eq. (12) and Eq. (13). Here, h_f shows the effective thickness of fluid given as follows :

$$h_f = \operatorname{Re}\left(\frac{J_n(\lambda R)}{\partial J_n(\lambda R)/\partial r}\right), n=1, 2, \dots \quad (27)$$

The effective thickness of fluid depends on the order of circumferential mode and the characteristic value. The velocity of internal fluid makes effects on damping and stiffness matrix of the structure of cylindrical shell. The stationary fluid, velocity $U=0$, acts only on mass matrix as an added mass.

2.4 Frequency response

The characteristic value, λ , depends on the order, n , of circumferential mode. And the effective thickness of fluid, h_f , given in Eq. (27), depends on the characteristic value λ . Thus, the effective thickness, h_f , can be obtained according to the order n . The coupled equation of motion of a cylindrical shell conveying fluid, given in Eq. (23), must be solved according to the order, n , of circumferential mode.

To calculate the frequency response function, let us assume the external harmonic force applied to cylindrical shell as

The beam-like shell element can reduce the degree-of-freedom by assuming the circumferential modes. Instead, the equation of motion given in Eq. (23) should be solved for every circumferential mode, $n=0, 1, 2, \dots$. Referring to Eq. (23), the harmonic response of n -th order circumferential mode, $\{\bar{u}\}_n$, can be determined as the solution of the following algebraic equation

$$([k]_s + [k]_f) - \omega^2([m]_s + [m]_f) + j\omega[c]_f \{\bar{u}\}_n = \{\bar{f}\}_s \quad (30)$$

where,

$$\{\bar{u}\}_n = \{\bar{u}_{xn}, \bar{u}_{\theta n}, \bar{u}_{rn}\}^T$$

Since equations of motion are given by the superposition of the solution according to the order, n . The displacement of a cylindrical shell can be obtained as follows :

$$u_x = \sum_{n=0}^{\infty} \bar{u}_{xn} \cos n\theta e^{j(\omega t - \lambda_n x)} \quad (31)$$

$$u_\theta = \sum_{n=1}^{\infty} \bar{u}_{\theta n} \sin n\theta e^{j(\omega t - \lambda_n x)} \quad (32)$$

$$u_r = \sum_{n=0}^{\infty} \bar{u}_{rn} \cos n\theta e^{j(\omega t - \lambda_n x)} \quad (33)$$

The frequency response function (F.R.F.) can be estimated from Eq. (30) by setting external force equal to unity.

3. Numerical Examples

A straight cylindrical shell with length $L=0.231$ m, radius $R=0.07725$ m and thickness $h=0.0015$ m was considered as a numerical model. The material of shell was taken as steel with density $\rho_s=7800$ kg/m³, Poisson's ration $\nu=0.3$ and Young's Modulus $E=2.05 \times 10^{11}$ N/m². The first case was a shell not containing fluid. The second case was a shell containing stationary fluid. The results by the presented method in the first and second case were compared with those by Nastran. Final case is a shell with the internal fluid which has uniform velocity. All cases have clamped-free boundary conditions as shown in Fig. 3.

Table 1 Degree of freedom of analysis model

	Nastran (shell element)	Presented
The number of circumferential node	36	—
The number of axial node	21	21
The number of total node	756	21
D.O.F per node	5	4
Total D.O.F of model	3780	48

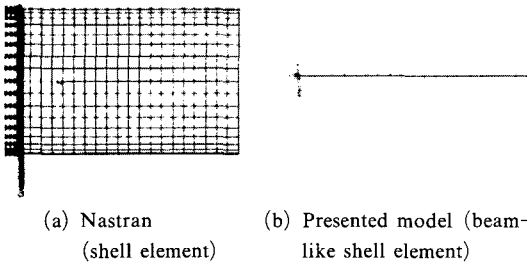

Fig. 3 Element Type used in Numerical example

Figure 3 shows the element type used in the numerical example. The shell element used in Nastran has 5 degree of freedom per node and needs additional division into 36 elements in circumferential direction. But the presented model doesn't need the circumferential element and has 4 degree of freedom per node. The reason is that the presented model has assumed the circumferential mode analytically. Table 1 shows the number of nodes and degrees-of-freedom used for the analysis. The cylindrical shell was divided equally into 20 elements in the axial direction for both Nastran (shell element) model and the presented (beam-like shell element) model. So, the number of degree-of-freedom by the presented method was further less than that by Nastran. Instead, the presented method must solve the equations of motion for every order of circumferential mode, $n=0, 1, 2, \dots$.

3.1 A cylindrical shell without fluid

Table 2 showed the results by the experiments (Mazuch et al., 1996), Nastran (2001) and the presented method. Here, n is the order of a circumferential mode and m is the order of an axial

Table 2 Natural frequency of the shell without fluid

Mode		Natural Frequency [Hz]		
m	n	Experiment (Mazuch et al., 1996)	Nastran (shell element)	Presented (beam-like shell element)
1	3	616	645	635
1	2	708	818	816
1	4	945	983	948
1	5	1479	1572	1480
2	4	1628	1709	1657
1	1	—	1824	1827
2	5	1851	1939	1844
2	3	1969	2074	2039
1	6	2151	2349	2154
2	6	—	2581	2387

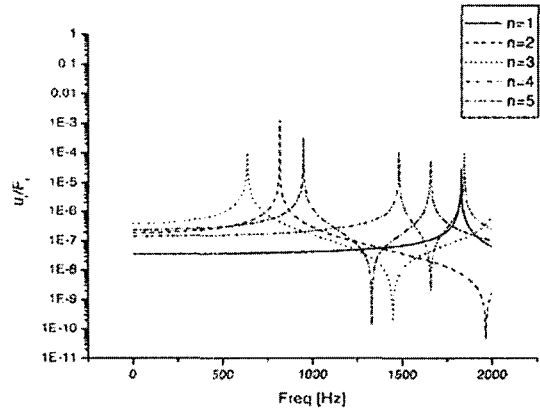

Fig. 4 A typical receptance of the shell according to the order of n circumferential mode

mode. Calculating results correspond well with experimental results. Therefore, natural frequencies of the shell can be obtained effectively by using a few elements. Figure 4 showed the F.R.F. of the shell according to the order of the circumferential mode. An external force in radial direction, F_r , was applied on cylindrical shell and receptance (displacement/force) was obtained at the driving point. Figure 5 showed the comparison of the F.R.F. with the presented method and Nastran. The summation of the receptances shown in Fig. 4 is equal to the solid line in Fig. 5. The presented method showed the

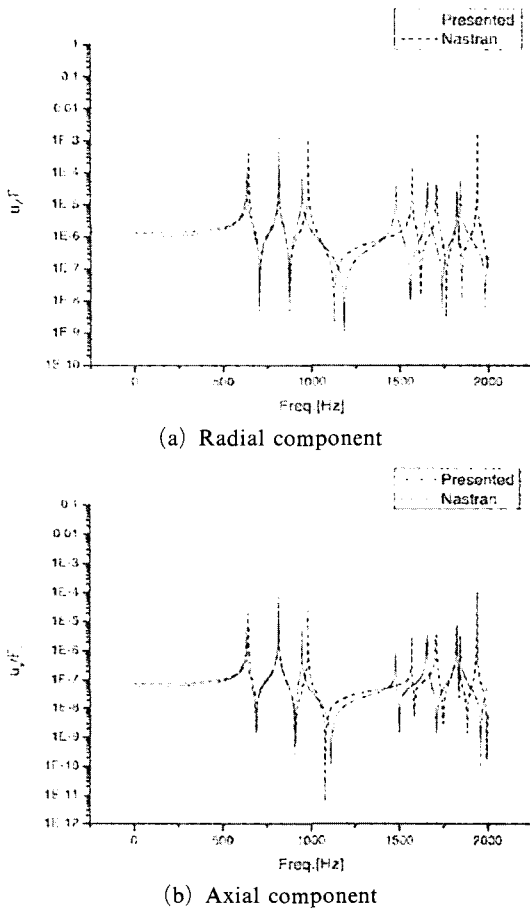

Fig. 5 Receptance of the empty shell

reasonable results for both radial and axial component comparing with the results by Nastran. The discrepancy of F.R.F. is due to the discrepancy of natural frequencies shown in Table 2.

3.2 A cylindrical shell with stationary fluid

In case that the shell is containing stationary fluid, the fluid has an effect on the structure of cylindrical shell as an added mass. Table 3 showed that the natural frequencies decreased for all modes comparing with the empty shell. The numerical results correspond well with experimental results (Mazuch et al., 1996). Table 4 showed the thickness (h_f) of fluid which has the effect as an added mass according to the circumferential mode. At the first circumferential mode, the thickness of fluid was the same as the radius of shell. It means the fluid acts entirely on the added mass.

Table 3 Natural frequency of the shell with stationary fluid

Mode		Natural Frequency [Hz]		
m	n	Experiment (Mazuch et al., 1996)	Nastran (shell element)	Presented (beam-like shell element)
1	3	388	404	373
1	2	421	480	434
1	4	628	652	602
1	1	—	1036	883
1	5	1027	1092	996
2	4	1094	1140	1054
2	5	1299	1360	1242
2	3	1245	1306	1202
1	6	1546	1699	1515
2	6	1748	1885	1680

Table 4 Effective thickness according to the order of circumferential mode

n	h_f/R
1	1.000
2	0.500
3	0.333
4	0.251
5	0.202

But, the higher the circumferential modes, the less the effective thickness of fluid acts on the shell. Figure 6 shows the F.R.F. by Nastran and the presented method. The results have a little difference. The reason is that Nastran and the presented method have a difference considering the effect of the internal fluid. The added mass of the fluid is considered to be constant in Nastran, but in this paper, not only the added mass but also the stiffness and the damping vary according to the circumferential mode.

3.3 The effects of velocity of internal fluid on FRF and natural frequency

When the fluid has a constant velocity, it influences mass, damping and stiffness of the shell. Figure 7 showed the effects of the velocity of fluid on FRF of cylindrical shell. As the velocity of

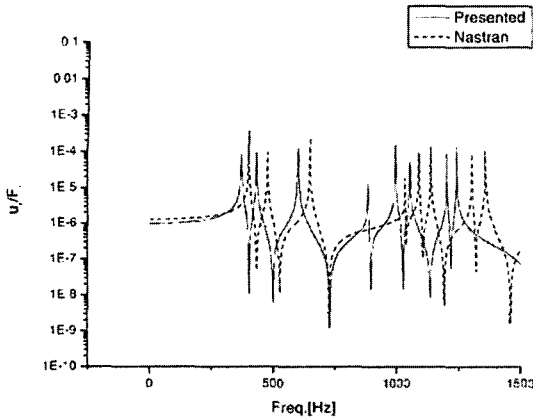

(a) Radial component

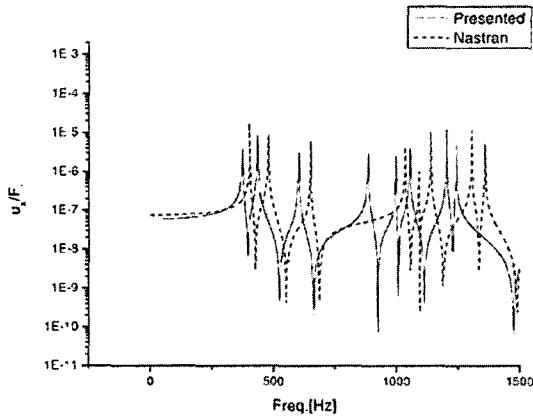

(b) Axial component

Fig. 6 Receptance of the shell with stationary fluid

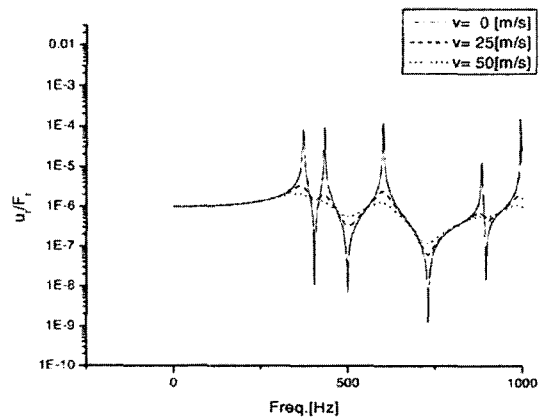

(a) Radial component

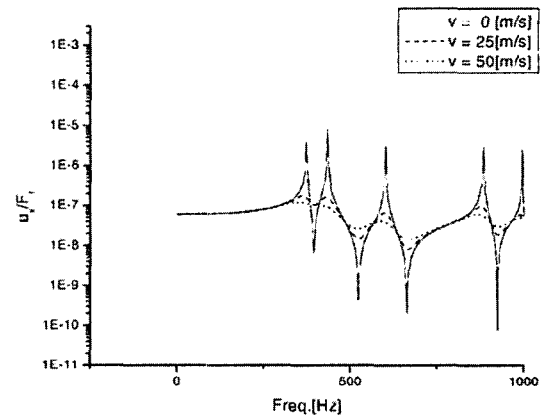

(b) Axial component

Fig. 7 Effect of fluid velocity on receptance of shell

the fluid increases, damping increases at resonance and natural frequencies shift down. The comparison with Nastran is not available since Nastran cannot solve this kind of problem. If the fluid velocity goes up over the critical velocity, the first resonance frequency becomes negative and the system becomes unstable.

4. Conclusions

(1) A cylindrical shell conveying fluid with uniform velocity was formulated by the finite element method. A beam-like shell element is used instead of conventional shell element. Further less number of elements could be used by this method compared with conventional shell type element. The accuracy by this method was not inferior to that by conventional shell type element.

(2) The estimation of frequency response function of cylindrical shell was presented with taking into consideration of the coupled effects of internal fluid with uniform velocity. The results by this method were compared with experiments (Mazuch et al., 1996) and those by Nastran.

(3) The effects of effective thickness of the internal fluid were estimated. The first circumferential mode, the effective thickness was the same as the shell element. The higher the mode becomes, the thinner effective thickness was.

(4) The stationary fluid only had an added-mass effect on the cylindrical shell. The internal fluid with velocity had effects on the damping and stiffness of the cylindrical shell. As the velocity of the fluid increased, the stiffness decreased and the damping increased, which make natural frequencies lower and peak value smaller.

Acknowledgment

The authors would like to thank the Ministry of Science and Technology of Korea for its financial support through a grant (M1-0230-00-0017) under the NRL (National Research Laboratory) project.

References

- Chen, W. Q., Ding, H. J., Guo, Y. M. and Yang, Q. D., 1997, "Free Vibrations of Fluid-Filled Orthotropic Cylindrical Shells," *Journal of Engineering Mechanics*, Vol. 123, pp. 1130~1133.
- Donnel, L. H., 1993, *Stability of Thin Walled Tubes Under Tension*, NACA Report No. 479.
- Ginsberg, J. H., 1973, "The Dynamic Stability of a Pipe Conveying a Pulsatile Flow," *International Journal of Engineering Science*, Vol. 11, pp. 1013~1024.
- Jain, R. K., 1974, "Vibration of Fluid-Filled Orthotropic Cylindrical Shells," *Journal of Sound and Vibration*, Vol. 37, pp. 379~388.
- Lee, S. Y. and Park, J. S., 1999, "Nonlinear Finite Element Analysis of a Laminated Cylindrical Shell with Transverse Matrix Cracks," *KSME International Journal*, Vol. 13, pp. 818~826.
- Love, A. E. H., 1952, *A Treatise on the Mathematical Theory of Elasticity*, Cambridge University Press, Cambridge.
- MSC/NASRAN User's Manual, Version 2001, *MSC Software Corporation*, U.S.A.
- Mazuch, T., Horacek, J., Trnka, J. and Vesely, J., 1996, "Natural Modes and Frequencies of a Thin Clamped-Free Steel Cylindrical Storage Tank Partially Filled with Water: FEM and Measurement," *Journal of Sound and Vibration*, Vol. 193, pp. 669~690.
- Paidoussis, M. P. and Issid, N. T., 1974, "Dynamic Stability of Pipes Conveying Fluid," *Journal of Sound and Vibration*, Vol. 33, pp. 267~294.
- Paidoussis, M. P. and Sundararajan, C., 1975, "Parametric and Combination Resonances of a Pipe Conveying Pulsating Fluid," *Journal of Applied Mechanics*, Vol. 42, pp. 780~784.
- Petyt, M., 1990, *Introduction to Finite Element Vibration Analysis*, Cambridge University Press, Cambridge.
- Ryu, C. H. and Lee, Y. S., Choi, M. H. and Kim, Y. W., 2004, "A Study on Stress Analysis of Orthotropic Composite Cylindrical Shells with a Circular or an Elliptical Cutout," *KSME International Journal*, Vol. 18, pp. 808~813.
- Sanders, J. L., 1963, "Nonlinear Theories for Thin Shells," *Quarterly of Applied Mathematics*, Vol. 21, pp. 21~36.
- Selmane, A. and Lakis, A. A., 1997, "Vibration Analysis of Anisotropic Open Cylindrical Shells Subjected to a Flowing Fluid," *Journal of Fluids and Structures*, Vol. 11, pp. 111~134.
- Zhang, Y. L., Gorman, D. G. and Reese, J. M., 2001, "A Finite Element Method for Modeling the Vibration of Initially Tensioned Thin-Walled Orthotropic Cylindrical Tubes Conveying Fluid," *Journal of Sound and Vibration*, Vol. 245, pp. 93~112.